

**N-Channel Dual-Gate MOSFET**

**Description**

The TMF3202Z is an enhancement type N-channel field-effect transistor. The source and substrate are interconnected. Internal bias circuits enable DC stabilization and a very good cross-modulation performance during AGC. Integrated diodes between the gates and source protect against excessive input voltage surges. The transistor has a SOT343 micro-miniature plastic package.

**Features**

- Gain controlled amplifier with AGC
- Integrated gate protection diodes
- High AGC-range, high gain, low noise figure

**Applications**

- Gain controlled input stage for UHF and VHF tuners
- Professional communications equipment

SOT343

Unit in mm

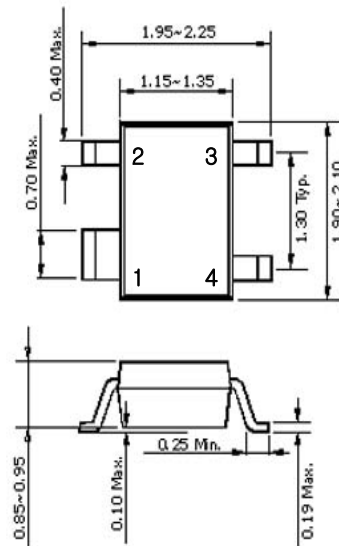

1. SOURCE    3. GATE 2  
2. DRAIN    4. GATE 1

**Absolute Maximum Ratings (T<sub>a</sub> = 25 °C)**

Parameter	Symbol	Ratings	Unit
Drain-Source Voltage	V <sub>DS</sub>	10	V
Drain Current	I <sub>D</sub>	30	mA
Gate 1 Current	I <sub>G1</sub>	±10	mA
Total Power Dissipation	P <sub>tot</sub>	200	mW
Storage Temperature	T <sub>stg</sub>	-65 ~ 150	°C
Operating Junction Temperature	T <sub>j</sub>	150	°C

**Caution :** Electro Static Discharge sensitive device, observe handling precaution

**DC Characteristics**

(  $T_j = 25\text{ }^\circ\text{C}$ , unless otherwise specified )

PARAMETER	SYMBOL	CONDITION	MIN.	MAX.	UNIT
Drain-source breakdown voltage	$V_{(BR)DSS}$	$V_{G1-S}=V_{G2-S}=0; I_D=10\mu A$	10	-	V
Gate1-source breakdown voltage	$V_{(BR)G1-SS}$	$V_{G2-S}=V_{DS}=0; I_{G1-S}=10\text{mA}$	6	10	V
Gate2-source breakdown voltage	$V_{(BR)G2-SS}$	$V_{G1-S}=V_{DS}=0; I_{G2-S}=10\text{mA}$	6	10	V
Forward source-gate1 voltage	$V_{(F)S-G1}$	$V_{G2-S}=V_{DS}=0; I_{S-G1}=10\text{mA}$	0.5	1.5	V
Forward source-gate2 voltage	$V_{(F)S-G2}$	$V_{G1-S}=V_{DS}=0; I_{S-G2}=10\text{mA}$	0.5	1.5	V
Gate1-source threshold voltage	$V_{G1-S(th)}$	$V_{DS}=5\text{V}; V_{G2-S}=4\text{V}; I_D=100\mu A$	0.3	1.0	V
Gate2-source threshold voltage	$V_{G2-S(th)}$	$V_{DS}=5\text{V}; V_{G1-S}=4\text{V}; I_D=100\mu A$	0.3	1.2	V
Drain-source current	$I_{DSX}$	$V_{G2-S}=4\text{V}; V_{DS}=5\text{V}; R_G=62\text{k}\Omega$	8	16	mA
Gate1 cut-off current	$I_{G1-S}$	$V_{G1-S}=5\text{V}; V_{G2-S}=V_{DS}=0$	-	10	nA
Gate2 cut-off current	$I_{G2-S}$	$V_{G2-S}=5\text{V}; V_{G1-S}=V_{DS}=0$	-	10	nA

**AC Characteristics**

( Common source;  $T_a = 25\text{ }^\circ\text{C}$ ,  $V_{G2-S} = 4\text{V}$ ,  $V_{DS} = 5\text{V}$ ,  $I_D = 12\text{mA}$  ; unless otherwise specified )

PARAMETER	SYMBOL	CONDITIONS	MIN.	TYP.	MAX.	UNIT
Forward transfer admittance	$ y_{FS} $	$T_j=25\text{ }^\circ\text{C}$	25	30	40	mS
Input capacitance at gate1	$C_{ig1-ss}$	$f=1\text{MHz}$	-	1.7	2.2	pF
Input capacitance at gate2	$C_{ig2-ss}$	$f=1\text{MHz}$	-	3.3	-	pF
Output capacitance	$C_{oss}$	$f=1\text{MHz}$	-	0.9	-	pF
Reverse transfer capacitance	$C_{rss}$	$f=1\text{MHz}$	-	15	25	fF
Power gain	Gtr	$f=200\text{MHz}; Z_i = S_{11}^*, Z_o = S_{22}^*$	30	33	-	dB
		$f=400\text{MHz}; Z_i = S_{11}^*, Z_o = S_{22}^*$	27	30	-	dB
		$f=800\text{MHz}; Z_i = S_{11}^*, Z_o = S_{22}^*$	24	27	-	dB
Noise figure	NF	$f=400\text{MHz}; Z_i = S_{11 \text{ opt(NF)}}$	-	1.2	-	dB
		$f=800\text{MHz}; Z_i = S_{11 \text{ opt(NF)}}$	-	1.5	2.0	dB
Cross-modulation	$X_{mod}$	$k=1\%, fw=50\text{MHz}; funw=60\text{MHz AGC} = 0\text{dB}$	90	-	-	dB $\mu$ V
		$k=1\%, fw=50\text{MHz}; funw=60\text{MHz AGC} = 10\text{dB}$	-	92	-	dB $\mu$ V
		$k=1\%, fw=50\text{MHz}; funw=60\text{MHz AGC} = 40\text{dB}$	100	105	-	dB $\mu$ V

□ Equivalent circuit (Top view)

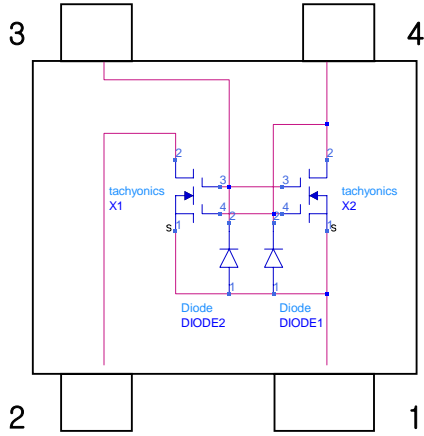

□ Making

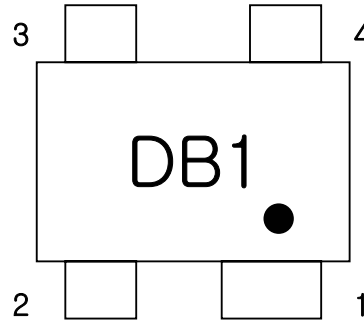

□ Pin Configuration

PIN	DESCRIPTION
1	SOURCE
2	DRAIN
3	GATE2
4	GATE1

□ Test circuit

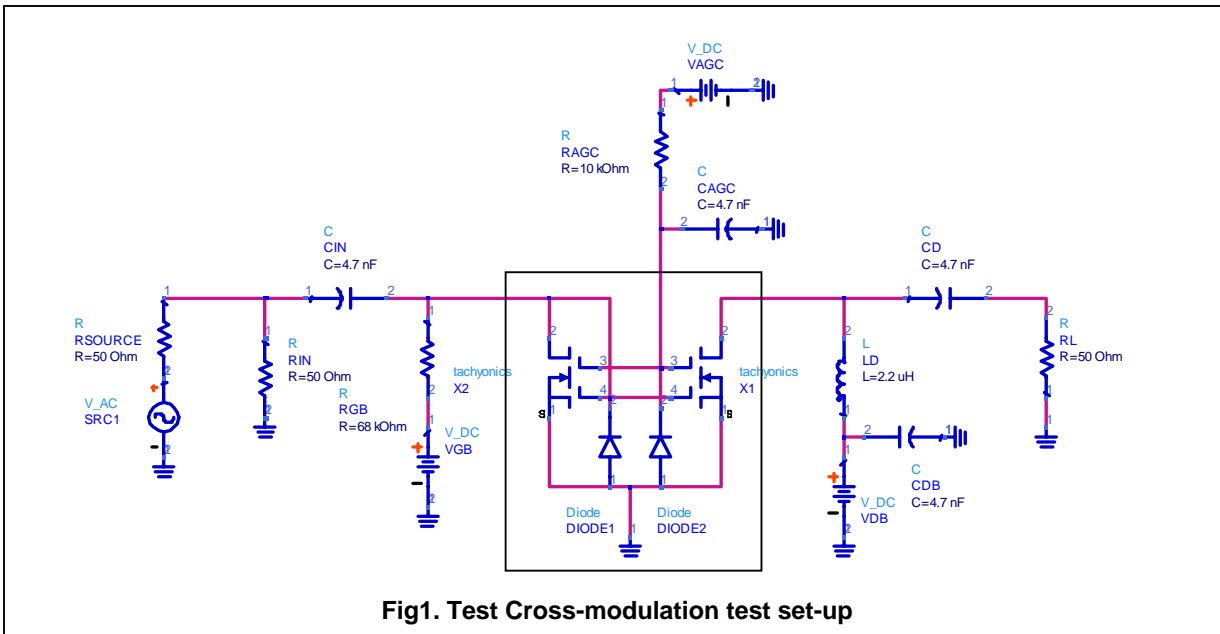
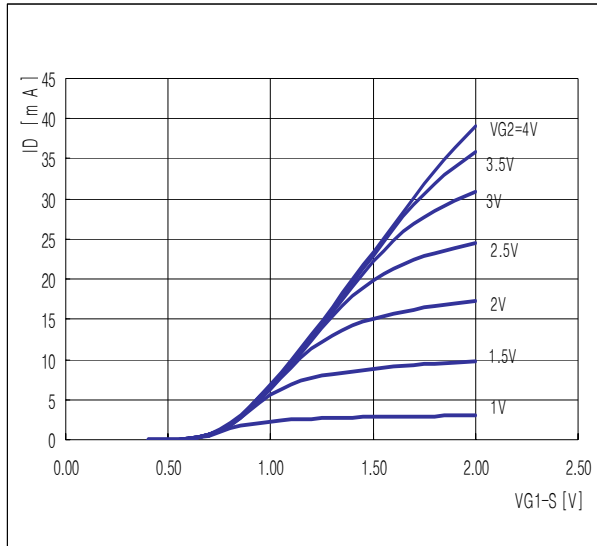

Fig1. Test Cross-modulation test set-up

□ Graphs



$V_{DS} = 5V, T_j = 25\text{ }^\circ\text{C}$

Fig.2 Transfer characteristics

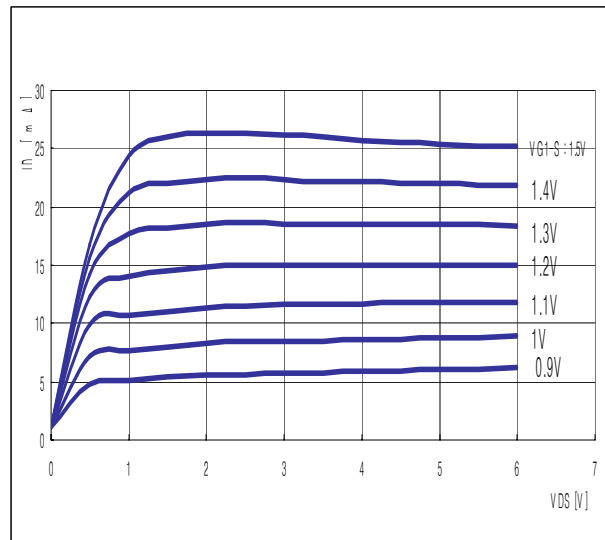

$V_{G2-S} = 4V, T_j = 25\text{ }^\circ\text{C}$

Fig.3. Output characteristics

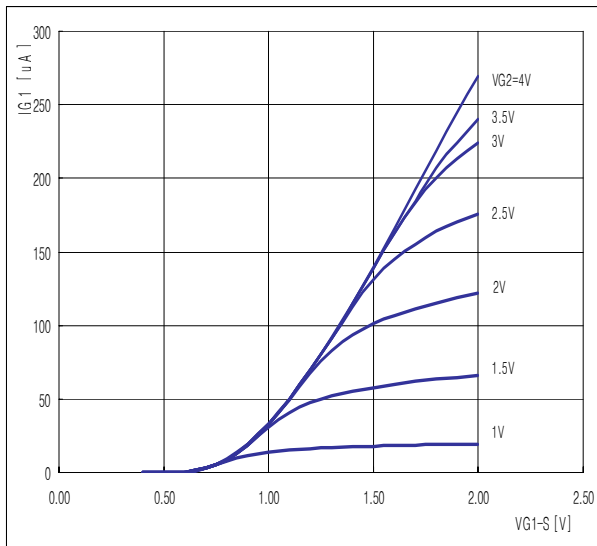

$V_{DS} = 5V, T_j = 25\text{ }^\circ\text{C}$

Fig.4 Gate1 Current as a function of gate1 Voltage

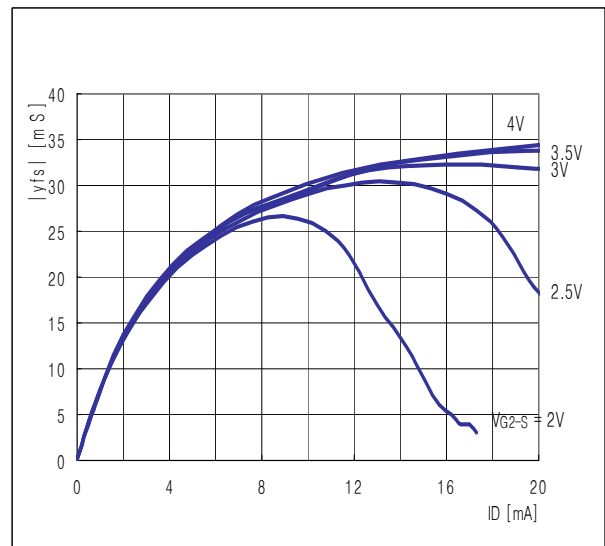

$V_{DS} = 5V, T_j = 25\text{ }^\circ\text{C}$

Fig.5. Forward transfer admittance as a function of drain current

□ Graphs

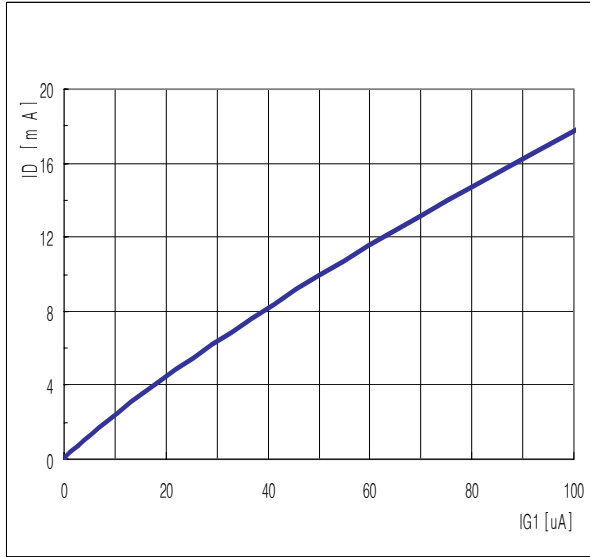

$V_{DS} = 5V, V_{G2-S} = 4V, T_j = 25\text{ }^\circ\text{C}$

Fig6. Drain current as a function of gate1 current

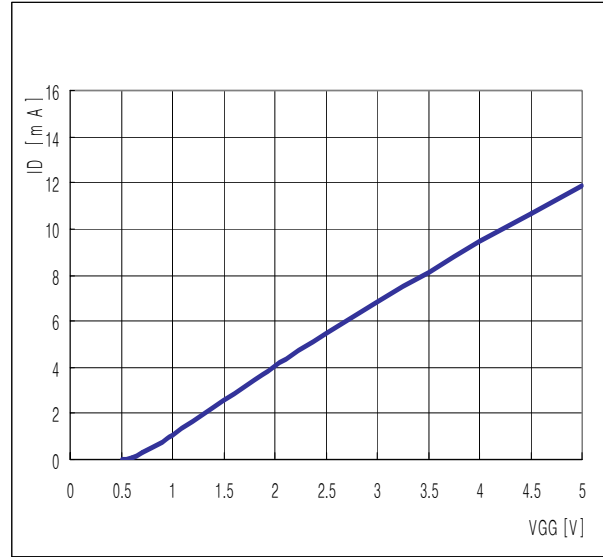

$V_{DS} = 5V, V_{G2-S} = 4V, R_{GB} = 62k\Omega, T_j = 25\text{ }^\circ\text{C}$

Fig7. Drain current as a function of gate1 supply voltage

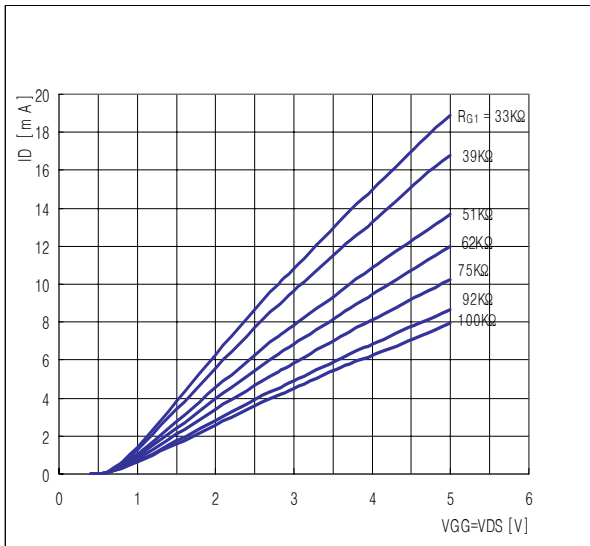

$V_{G2-S} = 4V, T_j = 25\text{ }^\circ\text{C}, R_{GB} = (\text{Connected to VGG})$

Fig8. Drain current as a function of gate1 and drain supply voltage ; see Fig1

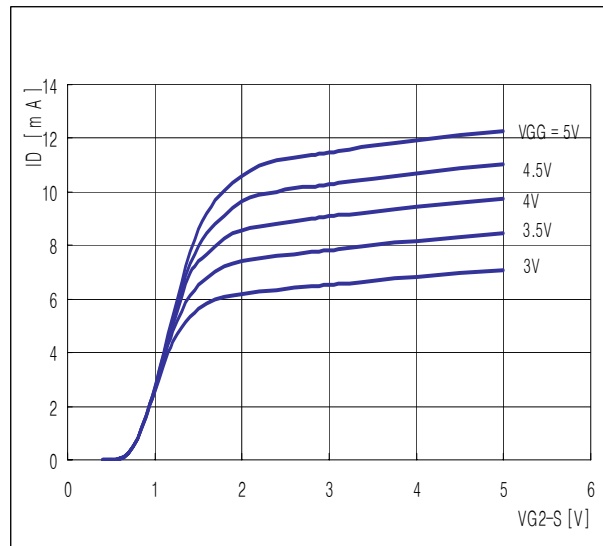

$V_{DS} = 5V, T_j = 25\text{ }^\circ\text{C}, R_{GB} = 62k\Omega$

Fig9. Drain current as a function of gate2 voltage

□ Graphs

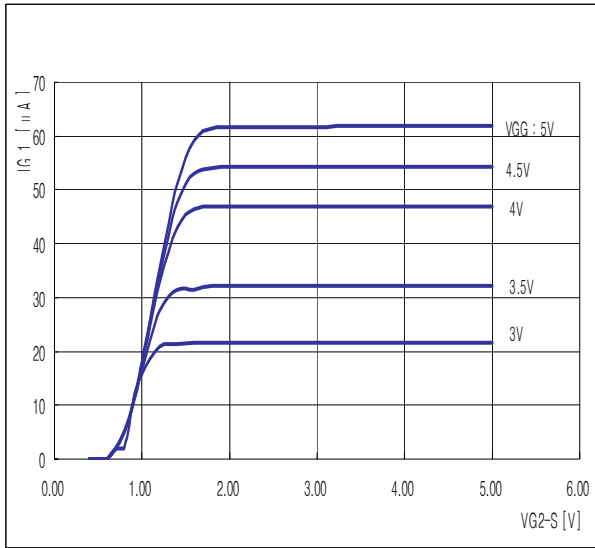

$V_{DS} = 5V$ ,  $R_{GB} = 62k\Omega$ ,  $T_j = 25\text{ }^\circ\text{C}$  ; Connected to VGB

Fig10. Gate1 current as a function of gate2 voltage

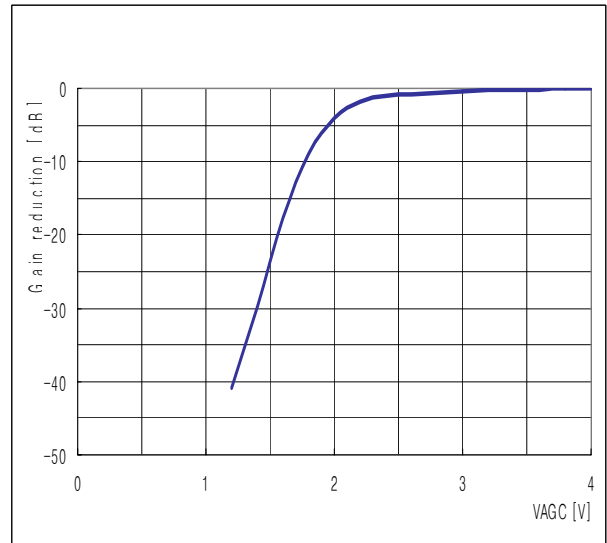

$f = 50\text{MHz}$ ,  $P_{in} = -30\text{dBm}$ ,  $V_{DS} = 5V$ ,  $V_{GB} = 5V$ ,  $R_{GB} = 62k\Omega$ ,  $T_j = 25\text{ }^\circ\text{C}$

Fig11. Typical Gain reduction as a function of AGC Voltage ; see Fig1

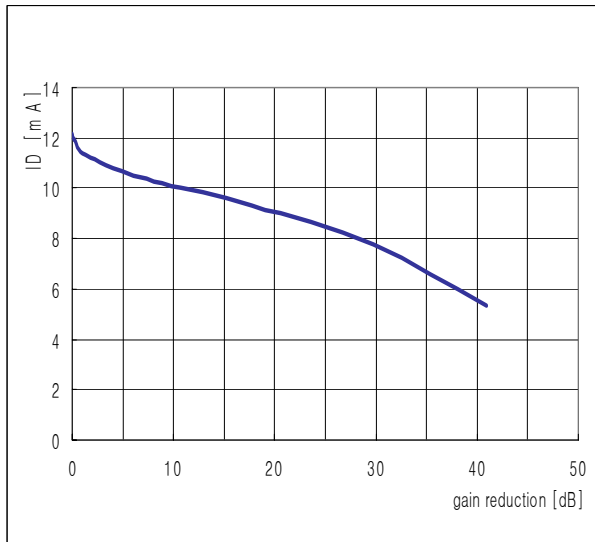

$f = 50\text{MHz}$ ,  $P_{in} = -30\text{dBm}$ ,  $V_{DS} = 5V$ ,  $V_{GB} = 5V$ ,  $R_{GB} = 62k\Omega$

Fig12. Drain current as a function of gain reduction ; see Fig1

□ Graphs

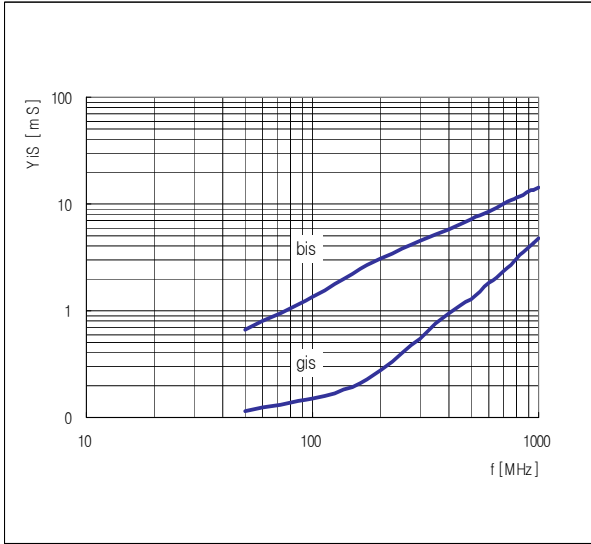

$V_{DS} = 5V, V_{G2-S} = 4V$

Fig13. Input admittance as a function of frequency

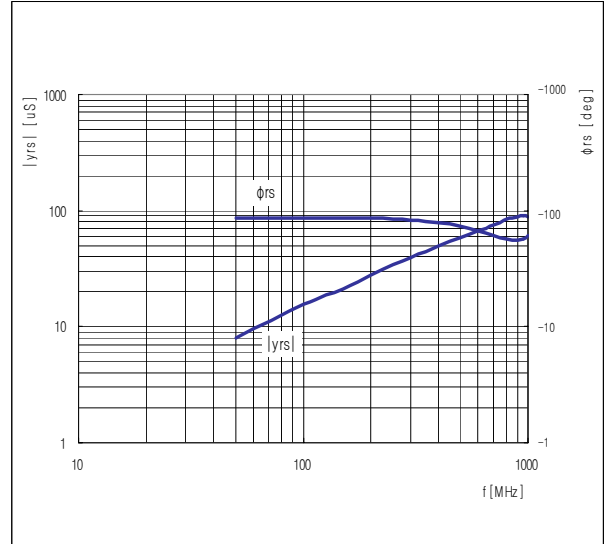

$V_{DS} = 5V, V_{G2-S} = 4V$

Fig14. Reverse transfer admittance and phase as a function of frequency

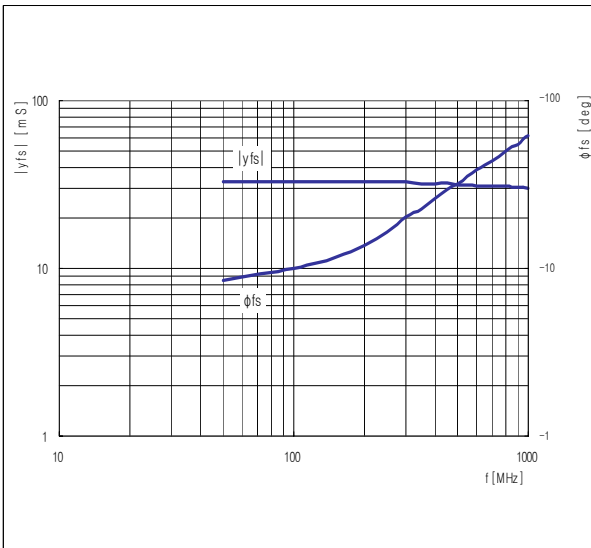

$V_{DS} = 5V, V_{G2-S} = 4V$

Fig15. Forward transfer admittance and phase as a function of frequency

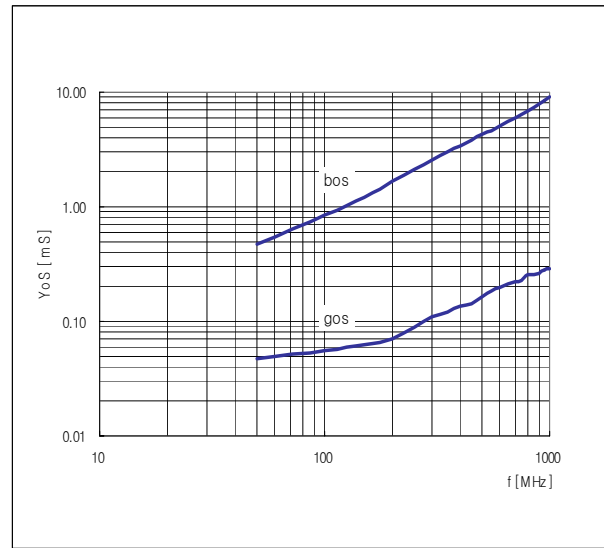

$V_{DS} = 5V, V_{G2-S} = 4V$

Fig16. Output admittance as a function of frequency

Scattering parameters

( $V_{G2-S} = 4V$ ,  $V_{DS} = 5V$ ,  $I_D = 12mA$ ,  $T_a = 25\text{ }^\circ\text{C}$ )

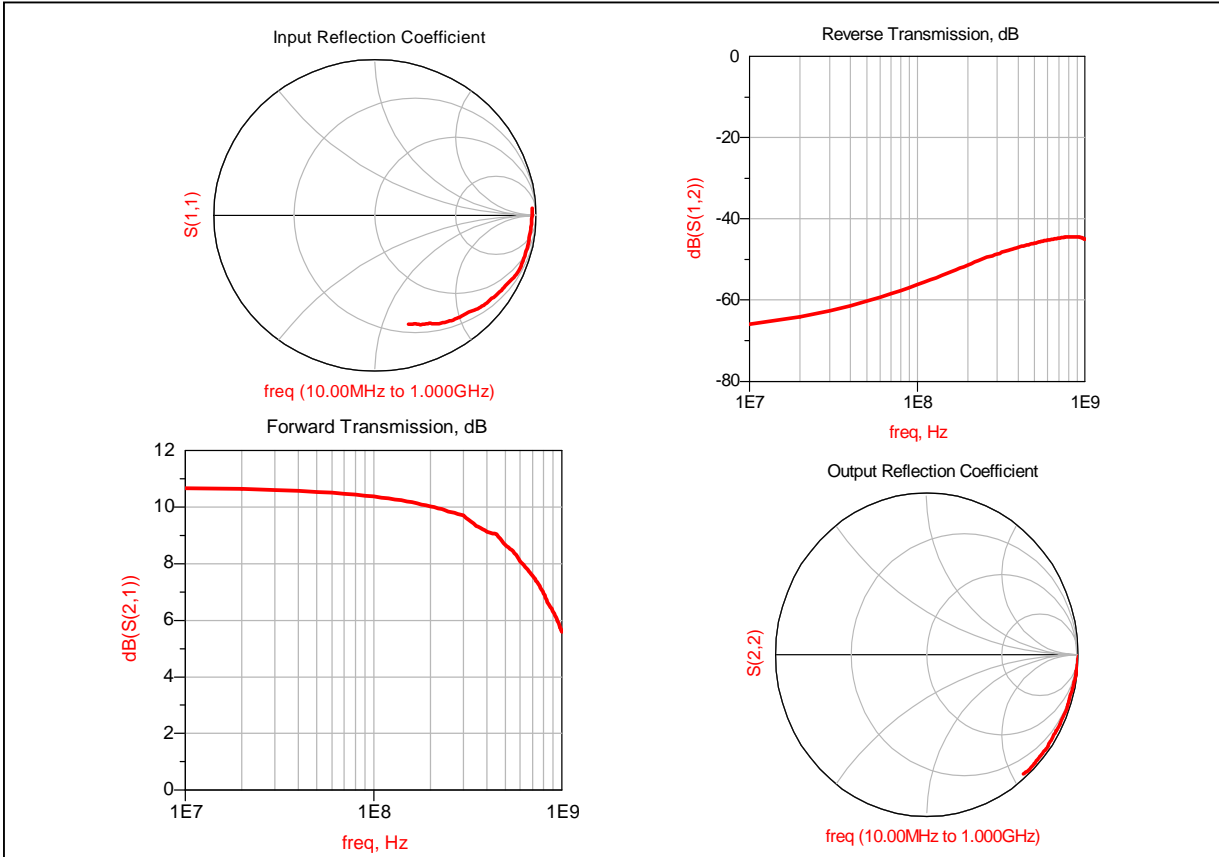

$V_{DS}=5V$ ,  $V_{G2-S}=4V$ ,  $I_D=12mA$

f (MHz)	S11		S21		S12		S22	
	Magnitude (ratio)	Angle (deg)	Magnitude (ratio)	Angle (deg)	Magnitude (ratio)	Angle (deg)	Magnitude (ratio)	Angle (deg)
50	0.897	0.974	3.93	171.7	0.001	93.0	1.006	-1.86
100	0.915	-5.323	3.81	165.5	0.001	91.7	0.998	-4.89
200	0.952	-17.920	3.58	153.1	0.002	89	0.982	-10.97
300	0.938	-27.300	3.40	141.5	0.002	89.2	0.968	-16.13
400	0.912	-35.160	3.20	130.8	0.003	92.6	0.966	-20.8
500	0.836	-43.000	3.04	120.1	0.004	95.6	0.964	-26.01
600	0.863	-50.800	2.89	110.1	0.004	100.4	0.968	-30.59
700	0.830	-57.600	2.75	98.8	0.004	104.6	0.968	-35.8
800	0.800	-63.470	2.62	87.8	0.004	110.7	0.973	-40.87