

E2V Technologies

CX1157 (Service Type CV6241)

Hydrogen-Filled Ceramic Thyatron

The data to be read in conjunction with the Hydrogen Thyatron Preamble.

ABRIDGED DATA

Hydrogen-filled tetrode thyatron with ceramic envelope, featuring low jitter and low anode delay time drift. Suitable for use at high pulse repetition rates and in applications requiring ruggedness and compactness. A hydrogen reservoir operating from the heater supply is incorporated.

Peak forward anode voltage	20	kV max
Peak anode current	350	A max
Average anode current	500	mA max
Anode heating factor	7.0×10^9	VApps max
Peak output power	3.5	MW max

GENERAL

Electrical

Cathode (connected internally to one end of heater)	oxide coated
Cathode heater voltage	$6.3 \pm 7\frac{1}{2}\%$ V
Cathode heater current	7.5 A
Reservoir heater voltage (see note 1)	$6.3 \pm 7\frac{1}{2}\%$ V
Reservoir heater current	1.5 A
Tube heating time (minimum)	3.0 min

Mechanical

Seated height	76.2 mm (3.000 inches) max
Clearance required below mounting flange	31.75 mm (1.250 inches) min
Overall diameter (mounting flange)	57.15 mm (2.250 inches) nom
Net weight	284 g (10 ounces) approx
Mounting position (see note 2)	any
Tube connections	see outline

Cooling

natural, forced-air or liquid
Where natural cooling is insufficient to maintain the envelope temperatures below the specified rated values, cooling by forced-air, or by oil or coolant immersion may be used.

The temperature of the anode terminal and the base, measured at the points indicated on the outline drawing, must not exceed the values specified below.

Anode terminal	250	°C max
Base	220	°C max

PULSE MODULATOR SERVICE

MAXIMUM AND MINIMUM RATINGS

(Absolute values)

	Min	Max	
Anode			
Peak forward anode voltage (see note 3)	-	20	kV
Peak inverse anode voltage (see note 4)	-	20	kV
Peak anode current	-	350	A
Average anode current	-	500	mA
Rate of rise of anode current (see notes 5 and 6)	-	2500	A/ μ s
Anode heating factor	-	7.0×10^9	VApps

Grid 2

Unloaded grid 2 drive pulse voltage (see note 7)	200	750	V
Grid 2 pulse duration	1.0	-	μ s
Rate of rise of grid 2 pulse (see note 6)	1.0	-	kV/ μ s
Grid 2 pulse delay	0.5	3.0	μ s
Peak inverse grid 2 voltage	-	200	V
Loaded grid 2 bias voltage (see note 8)	-50	-200	V
Forward impedance of grid 2 drive circuit	100	1000	Ω

Grid 1 - DC Primed (See note 9)

DC grid 1 unloaded priming voltage	75	150	V
DC grid 1 priming current	50	150	mA

Grid 1 - Pulsed (See note 10)

Unloaded grid 1 drive pulse voltage (see note 7)	300	750	V
Grid 1 pulse duration	2.0	-	μ s
Rate of rise of grid 1 pulse (see note 6)	1.0	-	kV/ μ s
Peak inverse grid 1 voltage	-	200	V
Loaded grid 1 bias voltage	-	see note 11	
Peak grid 1 drive current	0.15	0.5	A

Cathode

Heater voltage	$6.3 \pm 7\frac{1}{2}\%$	V
Heating time	3.0	min

Reservoir

Heater voltage (see note 1)	$6.3 \pm 7\frac{1}{2}\%$	V
Heating time	3.0	min

Environmental (See note 12)

Ambient temperature	-55	+130	°C
Altitude	-	3	km
	-	10 000	ft

CHARACTERISTICS

	Min	Typical	Max	
Critical DC anode voltage for conduction (see note 10)	-	0.2	0.3	kV
Anode delay time (see notes 10 and 13)	-	0.15	0.25	µs
Anode delay time drift (see notes 10 and 14)	-	20	50	ns
Time jitter (see note 10)	-	1.0	5.0	ns
Recovery time	see note 15 and curves			
Heater and reservoir current (at 6.3 V)	7.5	9.0	10.5	A

SINGLE-SHOT OR CROWBAR SERVICE

In applications requiring a very rapid rate of rise of anode current, the CX1157 geometry allows it to be mounted in a coaxial structure in order to minimise the total circuit inductance. Operation of the tube under the following ratings results in short anode delay times and very low time jitter.

MAXIMUM AND MINIMUM RATINGS (Absolute values)

	Min	Typical	Max	
Anode				
Peak forward anode voltage (see note 16)	-	-	20	kV
Peak anode current (see note 17)	-	-	3000	A
Average anode current	-	-	300	mA
Grid 2				
Unloaded grid 2 drive pulse voltage	0.5	1.0	2.0	kV
Grid 2 pulse duration	0.25	-	5.0	µs
Rate of rise of grid 2 pulse (unloaded)	10	30	-	kV/µs
Loaded grid 2 bias voltage	-50	-150	-200	V
Forward impedance of grid 2 drive circuit	50	50	500	Ω
Grid 1				
Grid 1 drive current (DC)	50	70	100	mA
Heaters				
Cathode heater voltage	5.8	6.8	7.0	V
Reservoir heater voltage	5.8	6.8	7.0	V

CHARACTERISTICS

Anode delay time (see note 18)	-	30	75	ns
Rate of rise of anode current (see notes 18 and 19)	-	100	-	kA/µs
Time jitter (see note 20)	-	<1.0	2.0	ns

NOTES

- The reservoir heater supply must be obtained either from the cathode heater supply or if a separate supply is used it must be decoupled to avoid damage to the reservoir.
- The tube must be mounted by means of its mounting flange.
- The maximum permissible peak forward voltage for instantaneous starting is 16 kV and there must be no overshoot.
- The peak inverse voltage including spike must not exceed 5.0 kV for the first 25 µs after the anode pulse.
- For single-shot or burst mode applications this parameter can exceed 100 kA/µs. The ultimate value which can be attained depends to a large extent upon the external circuit.
- This rate of rise refers to that part of the leading edge of the pulse between 25% and 75% of the pulse amplitude.
- Measured with respect to cathode. When grid 1 is pulse driven, the last 0.25 µs of the top of the grid 1 pulse must overlap the corresponding first 0.25 µs of the top of the delayed grid 2 pulse.
- The tube may be operated with a loaded grid 2 bias voltage of 0 to -50 V provided that care is taken to ensure that the peak grid 1 drive current is sufficiently low to prevent triode firing (tube control by the grid 1 pulse).
- When DC priming is used on grid 1, a negative bias of 100 to 200 V must be applied to grid 2 to ensure anode voltage hold-off. DC priming is especially suitable in crowbar service.
- Typical figures are obtained on test using conditions of minimum grid drive. Improved performance can be expected by increasing grid drive. Maximum life is obtained with a grid 1 pre-pulse.
- DC negative bias voltages must not be applied to grid 1. When grid 1 is pulse driven, the potential of grid 1 may vary between -10 and +5 V with respect to cathode potential during the period between the completion of recovery and the commencement of the succeeding grid pulse.
- To ensure a high standard of ruggedness, all tubes are subjected to the following tests. After each mechanical test all the tubes must then satisfy all electrical tests.
 - Vibration - The tubes are vibrated at 50 Hz with acceleration of 10 g for one minute in the direction of the cathode axis and then in one direction perpendicular to the cathode axis. See note 2.
 - Recovery Time - The tubes are tested for recovery at zero grid 2 bias voltage with a maximum limit of 35 µs. The tubes are subjected to the following tests on a sampling basis.
 - Operation under Vibration - The tubes are vibrated at 10 g in each of three planes at a sweep rate of one octave per minute from 20 to 500 to 20 Hz, under normal operating conditions. See note 2.

- (d) Survival under Vibration and Heater Cycling - The tubes are vibrated at 10 g at a sweep rate of one octave per minute from 5 to 500 Hz for 70 hours in each plane together with heater cycling of a 10 minute on/off cycle. See note 2.
 - (e) Long Duration Shock - The tubes are tested at 125 g for 10 ms with two blows in each plane. See note 2.
 - (f) High Temperature Test - The tubes are tested at a base temperature of 220 °C and an anode temperature of 250 °C under normal operating conditions for 5 hours. This implies an ambient temperature of 130 °C.
 - (g) Low Temperature Instant Start - The tubes are cooled to -20 °C and subjected to a 3-minute warm up period with 5.8 V on the heater. The tubes must withstand a snap start at 10 kV and operate satisfactorily.
 - (h) Standby-Life - The tubes are run with 6.3 V heater voltage applied for 500 hours.
13. The time interval between the instant when the unloaded grid 2 voltage passes cathode potential and the instant when anode conduction takes place.
 14. The drift in delay time over a period from 10 seconds to 10 minutes after reaching full voltage.
 15. The recovery characteristics are controlled on a sampling basis.
 16. For crowbar applications where the tube is required to hold off DC anode voltage for longer than 20 ms, the maximum peak forward anode voltage is 16 kV. If the reservoir voltage is increased above normal, the DC hold-off voltage may be reduced.
 17. For pulse durations not exceeding 0.25 μs.
 18. Shorter anode delay time and higher rate of rise of anode current may be obtained by increasing the cathode and reservoir heater voltages from 6.3 V to 6.8 V.
 19. The rate of rise of anode current obtainable is also dependent on the total circuit inductance and transmission line type matching.
 20. With the grid drive conditions specified, the anode delay time jitter will normally be less than 1.0 ns.

HEALTH AND SAFETY HAZARDS

E2V Technologies hydrogen thyratrons are safe to handle and operate, provided that the relevant precautions stated herein are observed. E2V Technologies does not accept responsibility for damage or injury resulting from the use of electronic devices it produces. Equipment manufacturers and users must ensure that adequate precautions are taken. Appropriate warning labels and notices must be provided on equipments incorporating E2V Technologies devices and in operating manuals.



High Voltage

Equipment must be designed so that personnel cannot come into contact with high voltage circuits. All high voltage circuits and terminals must be enclosed and fail-safe interlock switches must be fitted to disconnect the primary power supply and discharge all high voltage capacitors and other stored charges before allowing access. Interlock switches must not be bypassed to allow operation with access doors open.



X-Ray Radiation

All high voltage devices produce X-rays during operation and may require shielding. The X-ray radiation from hydrogen thyratrons is usually reduced to a safe level by enclosing the equipment or shielding the thyatron with at least 1.6 mm (¹/₁₆ inch) thick steel panels.

Users and equipment manufacturers must check the radiation level under their maximum operating conditions.

OUTLINE

(All dimensions without limits are nominal)

2395C

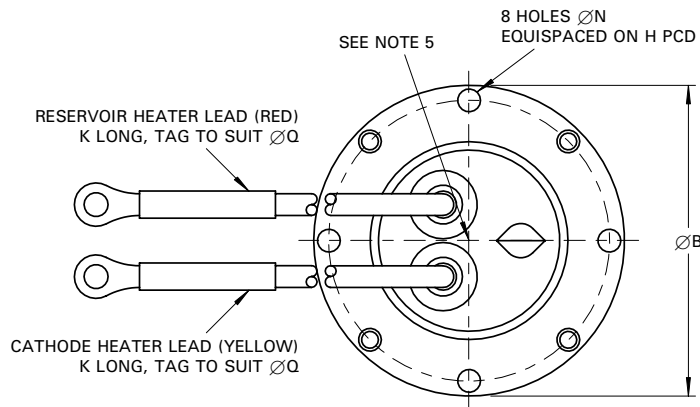
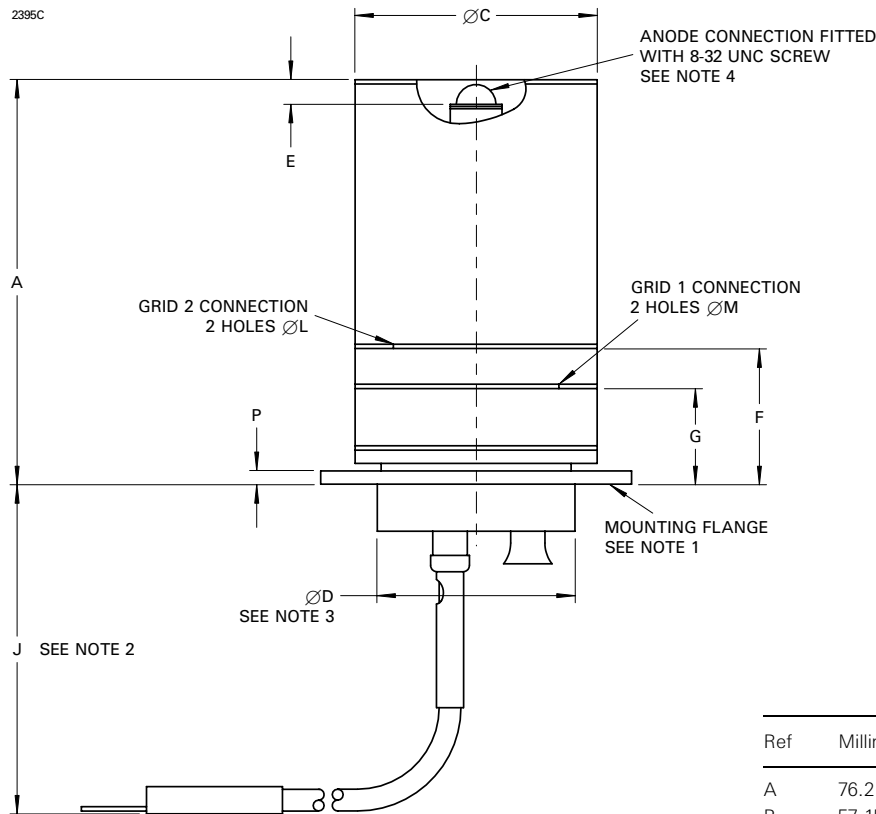

Ref	Millimetres	Inches
A	76.2 max	3.000 max
B	57.15	2.250
C	44.45 ± 0.79	1.750 ± 0.031
D	36.5	1.437
E	5.59 ± 0.38	0.220 ± 0.015
F	24.9	0.980
G	17.78	0.700
H	51.59 ± 0.25	2.031 ± 0.010
J	31.75 min	1.250 min
K	152.4	6.000
L	3.05	0.120
M	3.05	0.120
N	4.19	0.165
P	2.54	0.100
Q	4.19	0.165

Inch dimensions have been derived from millimetres.

Outline Notes

1. The mounting flange is the connection for the cathode, cathode heater return and reservoir heater return.
2. A minimum clearance of 31.75 mm (1.250 inches) must be allowed below the flange.
3. The recommended mounting hole is 38.10 mm (1.500 inches) diameter.
4. The anode temperature is measured at the base of the anode stem.
5. The base temperature is measured at this point.

MAXIMUM RECOVERY CHARACTERISTICS

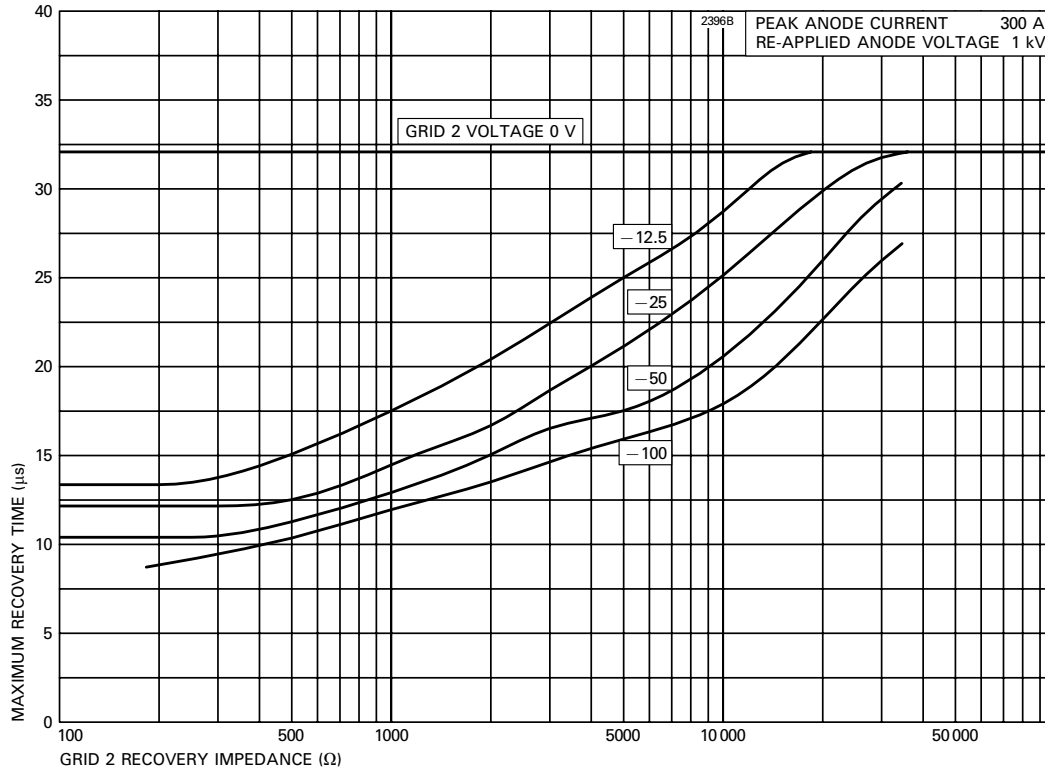

SCHEMATIC DIAGRAM

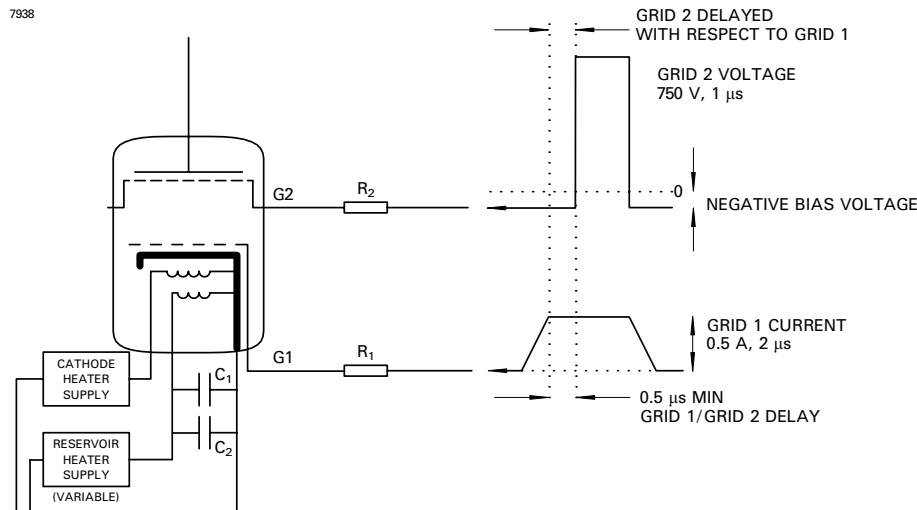

RECOMMENDED GRID, CATHODE AND RESERVOIR HEATER CONNECTIONS

- R_1 = Grid 1 series resistor. 12 W vitreous enamelled wirewound is recommended, of a total impedance to match the grid 1 drive pulse circuit.
- R_2 = Grid 2 series resistor. 12 W vitreous enamelled wirewound is recommended, of an impedance to match the grid 2 drive pulse circuit.
- C_1, C_2 = reservoir protection capacitors with a voltage rating ≥ 500 V;
 C_1 = 1000 pF low inductance (e.g. ceramic),
 C_2 = 1 μF (e.g. polycarbonate or polypropylene).

Components R_1 , R_2 , C_1 and C_2 should be mounted as close to the tube as possible.

Whilst E2V Technologies has taken care to ensure the accuracy of the information contained herein it accepts no responsibility for the consequences of any use thereof and also reserves the right to change the specification of goods without notice. E2V Technologies accepts no liability beyond that set out in its standard conditions of sale in respect of infringement of third party patents arising from the use of tubes or other devices in accordance with information contained herein.