

E2V Technologies CX1151 Hydrogen Thyatron

The data to be read in conjunction with the Hydrogen Thyatron Preamble.

ABRIDGED DATA

Hydrogen-filled tetrode thyatron, featuring low jitter and low anode delay time drift. Suitable for use at high pulse repetition rates, in parallel for switching higher powers, or for switching long pulses. A reservoir operating from the cathode heater supply is incorporated. The tube is flange mounted with flexible lead connections.

Peak forward anode voltage	25	kV max
Peak anode current	1.0	kA max
Average anode current	1.25	A max
Anode heating factor	14×10^9	VApps max
Peak output power	16.5	MW max

GENERAL

Electrical

Cathode (connected internally to mid-point of heater)	oxide coated
Heater voltage	$6.3 \pm 5\%$ V
Heater current	22 A
Tube heating time (minimum)	5.0 min
Inter-electrode capacitances (approximate):	
anode to grid 2 (grid 1 and cathode not connected)	13 pF
anode to grid 1 (grid 2 and cathode not connected)	7.5 pF
anode to cathode (grid 1 and grid 2 not connected)	26 pF

Mechanical

Seated height (excluding leads)	301.0 mm (11.850 inches) max
Overall diameter (excluding mounting flange)	84.12 mm (3.312 inches) max
Net weight	0.7 kg (1 1/2 pounds) approx
Mounting position (see note 1)	any
Top cap (see note 2)	B.S.448-CT3

Cooling	natural
--------------------------	---------

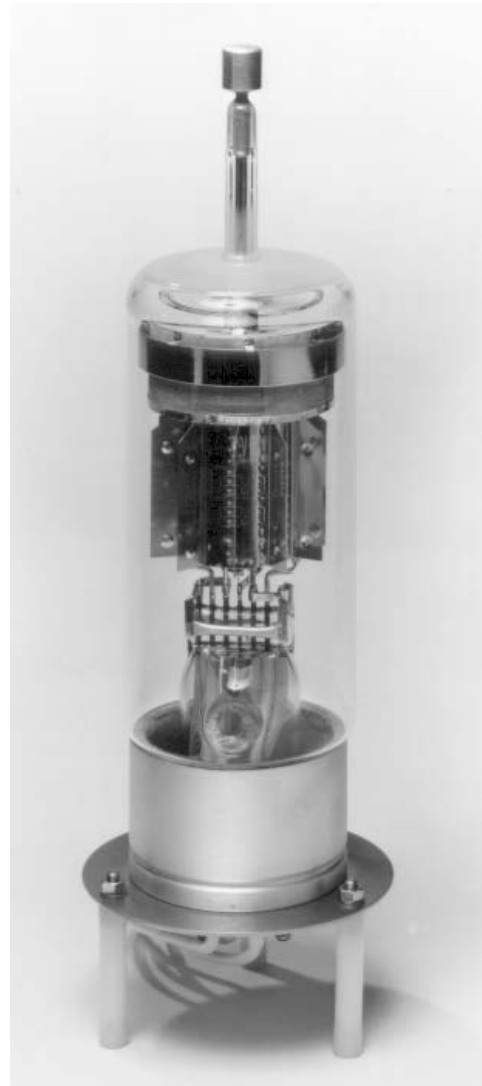

PULSE MODULATOR SERVICE MAXIMUM AND MINIMUM RATINGS (Absolute values)

	Min	Max
Anode		
Peak forward anode voltage (see note 3)	-	25 kV
Peak inverse anode voltage (see note 4)	-	25 kV
Peak anode current	-	1.0 kA
Peak anode current (pulse repetition rate limited to 60 pps max)	-	2.0 kA
Average anode current	-	1.25 A
Rate of rise of anode current (see note 5)	-	5.0 kA/μs
Anode heating factor	-	14×10^9 VApps

E2V Technologies Limited, Waterhouse Lane, Chelmsford, Essex CM1 2QU England Telephone: +44 (0)1245 493493 Facsimile: +44 (0)1245 492492
 e-mail: enquiries@e2vtechnologies.com Internet: www.e2vtechnologies.com Holding Company: Redwood 2002 Limited
 E2V Technologies Inc. 4 Westchester Plaza, PO Box 1482, Elmsford, NY10523-1482 USA Telephone: (914) 592-6050 Facsimile: (914) 592-5148
 e-mail: enquiries@e2vtechnologies.us

MAXIMUM AND MINIMUM RATINGS (Continued)

	Min	Max	
Grid 2			
Unloaded grid 2 drive pulse voltage (see note 6)	300	1000	V
Grid 2 pulse duration	1.0	-	μs
Rate of rise of grid 2 pulse (see note 5)	1.0	-	kV/μs
Grid 2 pulse delay	0.5	3.0	μs
Peak inverse grid 2 voltage	-	450	V
Loaded grid 2 bias voltage	-50	-150	V
Forward impedance of grid 2 drive circuit	50	800	Ω

Grid 1 – DC Primed (See note 7)

DC grid 1 unloaded priming voltage	75	150	V
DC grid 1 priming current	50	100	mA

Grid 1 – Pulsed

Unloaded grid 1 drive pulse voltage (see note 6)	300	1000	V
Grid 1 pulse duration	2.0	-	μs
Rate of rise of grid 1 pulse (see note 5)	1.0	-	kV/μs
Peak inverse grid 1 voltage	-	450	V
Loaded grid 1 bias voltage	see note 8		
Peak grid 1 drive current	0.3	1.0	A

Cathode

Heater voltage	6.3 ± 5%	V
Tube heating time	5.0	min

Environmental

Ambient temperature	-50	+90	°C
Altitude	-	3	km
	-	10 000	ft

CHARACTERISTICS

	Min	Typical	Max	
Critical DC anode voltage for conduction (see note 9)	-	0.5	2.0	kV
Anode delay time (see notes 9 and 10)	-	0.15	0.25	μs
Anode delay time drift (see notes 9, 11 and 12)	-	20	50	ns
Time jitter (see notes 9 and 12)	-	1.0	5.0	ns
Recovery time	see note 13 and curves			
Heater current (at 6.3 V)	18	22	25	A

RATINGS FOR SINGLE SHOT OR CROWBAR SERVICE (See note 7)

DC forward anode voltage	30	kV max
Peak anode current	15	kA max
Product of peak current and pulse length	0.6	A.s max
Repetition frequency	1 pulse per 10 s	max

NOTES

- The tube must be mounted by the base flange only.
- A large area anode connector, E2V Technologies type MA360A, is recommended.
- The maximum permissible peak forward voltage for instantaneous starting is 20 kV and there must be no overshoot.

- The peak inverse voltage must not exceed 25 kV for the first 25 μs after the anode pulse.
- This rate of rise refers to that part of the leading edge of the pulse between 25% and 75% of the pulse amplitude.
- Measured with respect to cathode. In certain cases the maximum drive pulse voltage may be exceeded without damage to the tube; a maximum value of 2.5 kV is then recommended. When grid 1 is pulse driven, the last 0.25 μs of the top of the grid 1 pulse must overlap the corresponding first 0.25 μs of the top of the delayed grid 2 pulse.
- When DC priming is used on grid 1, a negative bias of 100 to 200 V must be applied to grid 2 to ensure anode voltage hold-off. DC priming is recommended for crowbar service.
- DC negative bias voltages must not be applied to grid 1. When grid 1 is pulse driven, the potential of grid 1 may vary between -10 and +5 V with respect to cathode potential during the period between the completion of recovery and the commencement of the succeeding grid pulse.
- Typical figures are obtained on test using conditions of minimum grid drive. Improved performance can be expected by increasing the grid drive.
- The time interval between the instant at which the rising unloaded grid 2 pulse reaches 25% of its pulse amplitude and the instant when anode conduction takes place.
- The drift in delay time over a period from 10 seconds to 10 minutes after reaching full voltage.
- For equipment where jitter and anode delay time drift are not important, the tube may be triggered by applying a single pulse to grid 2 and connecting grid 1 to grid 2 via a 1000 pF capacitor shunted by a 0.1 MΩ resistor.
- The recovery characteristics are controlled on a sampling basis.

HEALTH AND SAFETY HAZARDS

E2V Technologies hydrogen thyratrons are safe to handle and operate, provided that the relevant precautions stated herein are observed. E2V Technologies does not accept responsibility for damage or injury resulting from the use of electronic devices it produces. Equipment manufacturers and users must ensure that adequate precautions are taken. Appropriate warning labels and notices must be provided on equipments incorporating E2V Technologies devices and in operating manuals.



High Voltage

Equipment must be designed so that personnel cannot come into contact with high voltage circuits. All high voltage circuits and terminals must be enclosed and fail-safe interlock switches must be fitted to disconnect the primary power supply and discharge all high voltage capacitors and other stored charges before allowing access. Interlock switches must not be bypassed to allow operation with access doors open.



X-Ray Radiation

All high voltage devices produce X-rays during operation and may require shielding. The X-ray radiation from hydrogen thyratrons is usually reduced to a safe level by enclosing the equipment or shielding the thyratron with at least 1.6 mm (¹/₁₆ inch) thick steel panels.

Users and equipment manufacturers must check the radiation level under their maximum operating conditions.

MAXIMUM RECOVERY CHARACTERISTICS

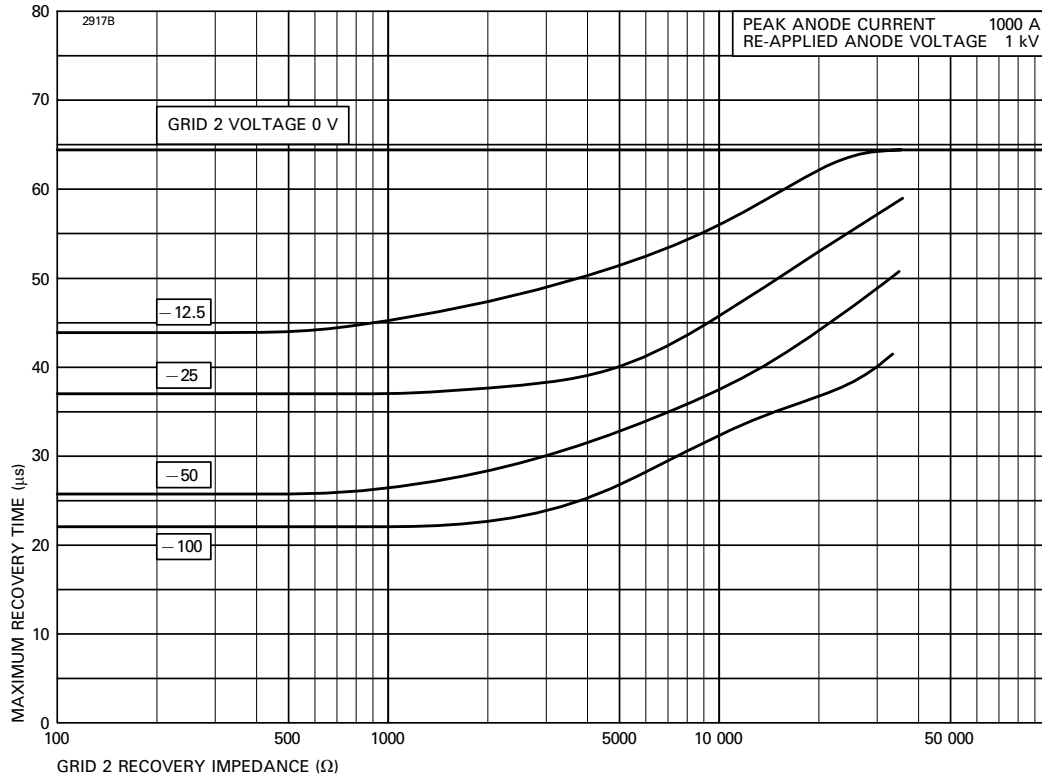

SCHEMATIC DIAGRAM

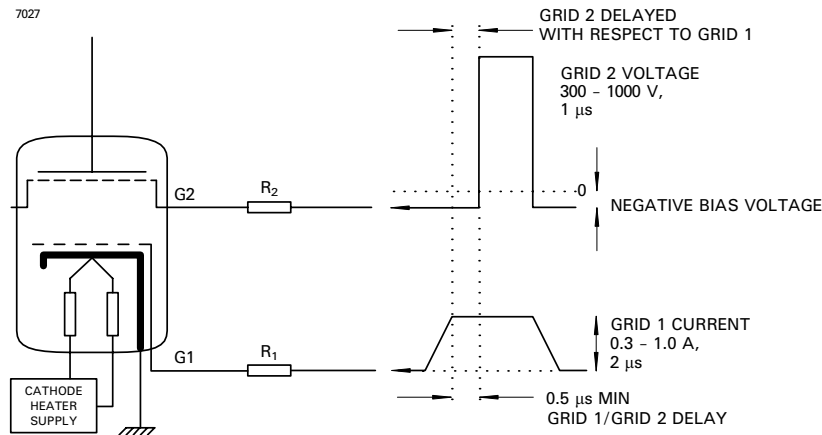

RECOMMENDED GRID AND CATHODE HEATER CONNECTIONS

R₁ = Grid 1 series resistor. 12 W vitreous enamelled wirewound is recommended, of a total impedance to match the grid 1 drive pulse circuit.

R₂ = Grid 2 resistor. 12 W vitreous enamelled wirewound is recommended, of an impedance to match the grid 2 drive pulse circuit.

Components R₁ and R₂ should be mounted as close to the tube as possible.

OUTLINE

(All dimensions without limits are nominal)

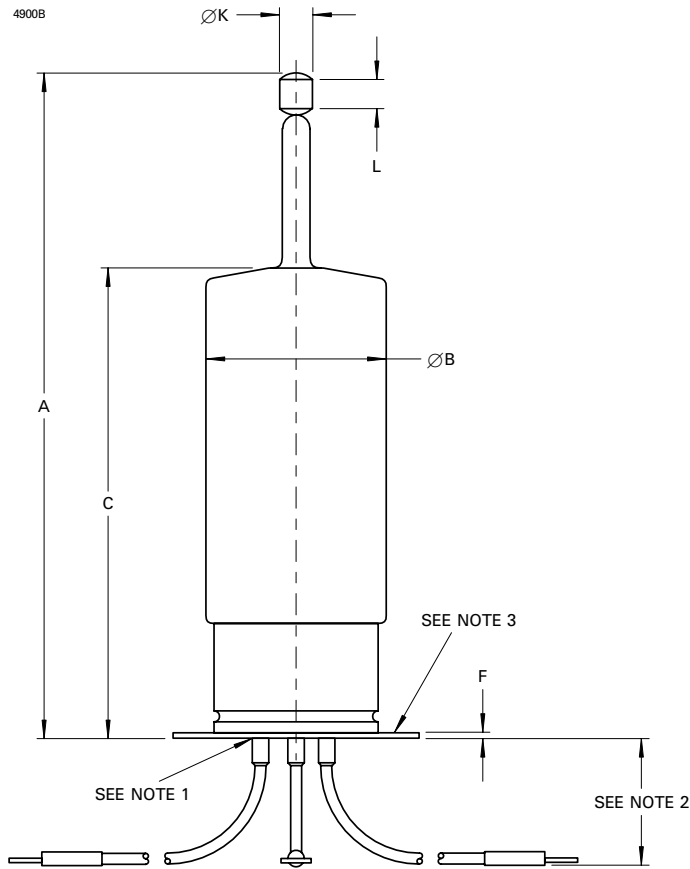

Ref	Millimetres	Inches
A	301.0 max	11.850 max
B	84.12 max	3.312 max
C	215.9 ± 13.0	8.500 ± 0.512
D	111.1	4.375
E	95.25	3.750
F	1.6	0.063
G	6.5	0.256
H	215.9	8.500
J	6.35	0.250
K	14.38 ± 0.18	0.566 ± 0.007
L	12.7 min	0.500 min

Inch dimensions have been derived from millimetres.

Outline Notes

1. The recommended hole in the mounting plate is 76 mm (3.0 inches) diameter.
2. A minimum clearance of 44.45 mm (1.75 inches) must be allowed below the mounting surface.
3. The mounting flange is the cathode connection and this is connected internally to the mid-point of the heater.

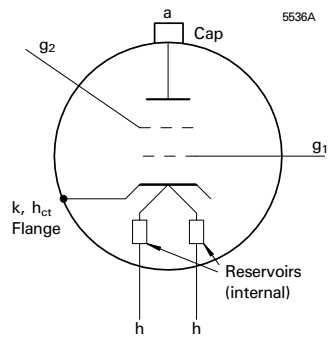
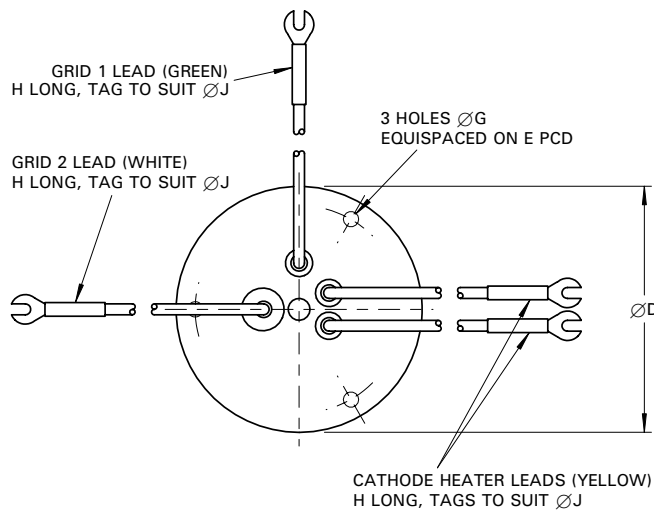

Whilst E2V Technologies has taken care to ensure the accuracy of the information contained herein it accepts no responsibility for the consequences of any use thereof and also reserves the right to change the specification of goods without notice. E2V Technologies accepts no liability beyond that set out in its standard conditions of sale in respect of infringement of third party patents arising from the use of tubes or other devices in accordance with information contained herein.