

ADVANCE INFORMATION

VPC323xD,
VPC324xD
Comb Filter Video
Processor

Edition Jan. 19, 1999
6251-472-1AI



Contents

Page	Section	Title
5	1.	Introduction
5	1.1.	System Architecture
6	1.2.	Video Processor Family
7	1.3.	VPC Applications
8	2.	Functional Description
8	2.1.	Analog Video Front-End
8	2.1.1.	Input Selector
8	2.1.2.	Clamping
8	2.1.3.	Automatic Gain Control
8	2.1.4.	Analog-to-Digital Converters
8	2.1.5.	Digitally Controlled Clock Oscillator
8	2.1.6.	Analog Video Output
9	2.2.	Adaptive Comb Filter
9	2.3.	Color Decoder
10	2.3.1.	IF-Compensation
10	2.3.2.	Demodulator
10	2.3.3.	Chrominance Filter
11	2.3.4.	Frequency Demodulator
11	2.3.5.	Burst Detection / Saturation Control
11	2.3.6.	Color Killer Operation
11	2.3.7.	Automatic standard recognition
12	2.3.8.	PAL Compensation/1-H Comb Filter
13	2.3.9.	Luminance Notch Filter
13	2.3.10.	Skew Filtering
13	2.4.	Component Interface Processor CIP
13	2.4.1.	Component Analogue Front End
13	2.4.2.	Matrix
13	2.4.3.	Component Y_C, C_b Control
14	2.4.4.	Softmixer
14	2.4.4.1.	Static Switch Mode
14	2.4.4.2.	Static Mixer Mode
14	2.4.4.3.	Dynamic Mixer Mode
15	2.4.5.	4:4:4 to 4:2:2 Downsampling
15	2.4.6.	Fast Blank and Signal Monitoring
15	2.5.	Horizontal Scaler
15	2.5.1.	Horizontal Lowpass-filter
16	2.5.2.	Horizontal Prescaler
16	2.5.3.	Horizontal Scaling Engine
16	2.5.4.	Horizontal Peaking-filter
17	2.6.	Vertical Scaler
17	2.7.	Contrast and Brightness
17	2.8.	Blackline Detector
17	2.9.	Control and Data Output Signals
17	2.9.1.	Line-Locked Clock Generation
18	2.9.2.	Sync Signals
18	2.9.3.	DIGIT3000 Output Format

Contents, continued

Page	Section	Title
18	2.9.4.	Line-Locked 4:2:2 Output Format
18	2.9.5.	Line-Locked 4:1:1 Output Format
18	2.9.6.	ITU-R 656 Output Format
20	2.9.7.	Output Code Levels
20	2.9.8.	Output Ports
20	2.9.9.	Test Pattern Generator
20	2.10.	PAL+ Support
20	2.10.1.	Output Signals for PAL+/Color+ Support
22	2.11.	Video Sync Processing
24	2.12.	Picture in Picture (PIP) Processing and Control
24	2.12.1.	Configurations
25	2.12.2.	PIP Display Modes
25	2.12.3.	Predefined Inset Picture Size
28	2.12.4.	Acquisition and Display Window
28	2.12.5.	Frame and Background Color
28	2.12.6.	Vertical Shift of the Main Picture
28	2.12.7.	Free Running Display Mode
28	2.12.8.	Frame and Field Display Mode
29	2.12.9.	External Field Memory
30	3.	Serial Interface
30	3.1.	I ² C-Bus Interface
30	3.2.	Control and Status Registers
49	3.2.1.	Calculation of Vertical and East-West Deflection Coefficients
49	3.2.2.	Scaler Adjustment
51	4.	Specifications
51	4.1.	Outline Dimensions
51	4.2.	Pin Connections and Short Descriptions
54	4.3.	Pin Descriptions (pin numbers for PQFP80 package)
57	4.4.	Pin Configuration
58	4.5.	Pin Circuits
59	4.6.	Electrical Characteristics
59	4.6.1.	Absolute Maximum Ratings
59	4.6.2.	Recommended Operating Conditions
60	4.6.3.	Recommended Crystal Characteristics
61	4.6.4.	Characteristics
61	4.6.4.1.	Characteristics, 5 MHz Clock Output
61	4.6.4.2.	Characteristics, 20 MHz Clock Input/Output, External Clock Input (XTAL1)
61	4.6.4.3.	Characteristics, Reset Input, Test Input, VGAV Input, YCOEQ Input
62	4.6.4.4.	Characteristics, Power-up Sequence
63	4.6.4.5.	Characteristics, FPDAT Input/Output
63	4.6.4.6.	Characteristics, I ² C Bus Interface
64	4.6.4.7.	Characteristics, Analog Video and Component Inputs
64	4.6.4.8.	Characteristics, Analog Front-End and ADCs
66	4.6.4.9.	Characteristics, Analog FB Input
67	4.6.4.10.	Characteristics, Output Pin Specification

Contents, continued

Page	Section	Title
69	4.6.4.11.	Characteristics, Input Pin Specification
70	4.6.4.12.	Characteristics, Clock Output Specification
71	5.	Application Circuit
72	5.1.	Application Note: VGA mode with VPC 3215C
73	5.2.	Application Note: PIP Mode Programming
73	5.2.1.	Procedure to Program a PIP Mode
73	5.2.2.	I ² C Registers Programming for PIP Control
75	5.2.3.	Examples
75	5.2.3.1.	Select Predefined Mode 2
75	5.2.3.2.	Select a Strobe Effect in Expert Mode
76	5.2.3.3.	Select Predefined Mode 6 for Tuner Scanning
78	6.	Data Sheet History

Comb Filter Video Processor

1. Introduction

The VPC 323xD/324xD is a high-quality, single-chip video front-end, which is targeted for 4:3 and 16:9, 50/60 and 100/120 Hz TV sets. It can be combined with other members of the DIGIT3000 IC family (such as DDP 33x0A/B, TPU 3040) and/or it can be used with 3rd-party products.

The main features of the VPC 323xD/324xD are

- high-performance adaptive 4H comb filter Y/C separator with adjustable vertical peaking
- multi-standard color decoder PAL/NTSC/SECAM including all substandards
- four CVBS, one S-VHS input, one CVBS output
- two RGB/YC_rC_b component inputs, one Fast Blank (FB) input
- integrated high-quality A/D converters and associated clamp and AGC circuits
- multi-standard sync processing
- linear horizontal scaling (0.25 ... 4), as well as non-linear horizontal scaling 'panorama vision'
- PAL+ preprocessing (VPC 323xD)
- line-locked clock, data and sync, or 656-output interface (VPC 323xD)

- display and deflection control (VPC 324xD)
- peaking, contrast, brightness, color saturation and tint for RGB/YC_rC_b and CVBS/S-VHS
- high-quality soft mixer controlled by Fast Blank
- PIP processing for four picture sizes ($\frac{1}{4}$, $\frac{1}{9}$, $\frac{1}{16}$, or $\frac{1}{36}$ of normal size) with 8 bit resolution
- 15 predefined PIP display configurations and expert mode (fully programmable)
- control interface for external field memory
- I²C-Bus Interface
- one 20.25 MHz crystal, few external components
- 80-pin PQFP package

1.1. System Architecture

Fig.1-1 shows the block diagram of the video processor

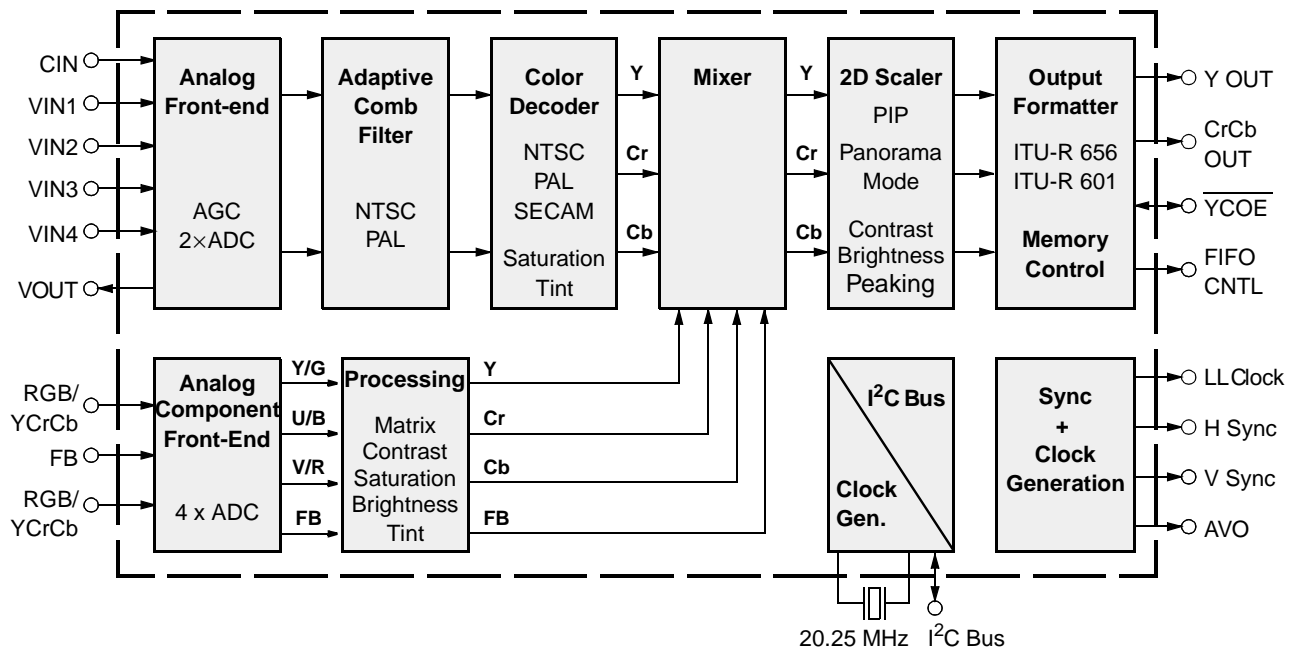

Fig. 1-1: .Block diagram of the VPC 323xD

1.2. Video Processor Family

The VPC video processor family supports 15/32-kHz systems and is available with different comb filter options. The 50-Hz/single-scan versions (e. g. VPC 324xD) provide controlling for the display and the

vertical/east-west deflection of DDP 3300A. The 100-Hz/double-scan versions (e. g. VPC 323xD) have a line-locked clock output interface and the PAL+ pre-processing option. Table 1–1 gives an overview of the VPC video processor family.

Table 1–1: VPC Processor Family for 100 Hz, Double Scan and Line Locked Clock Application

Typ	Features				
	Adaptive Combfilter (PAL/NTSC)	Panorama Vision	Analog Component Inputs	Vertical Scaler (PIP)	Digital Output Interface
VPC 3230D	4H	✓	2	✓	ITU-R 601, ITU-R 656
VPC 3231D		✓	2	✓	ITU-R 601, ITU-R 656
VPC 3232D	4H	✓		✓	ITU-R 601, ITU-R 656
VPC 3233D		✓		✓	ITU-R 601, ITU-R 656
VPC 3215C	4H	✓			ITU-R 601
VPC 3210A	2H	✓			ITU-R 601
VPC 3211A		✓			ITU-R 601

Table 1–2: VPC Processor Family for 50 Hz Single Scan Applications

Typ	Features				
	Adaptive Combfilter (PAL/NTSC)	Panorama Vision	Analog Component Inputs	Vertical Scaler (PIP)	Digital Output Interface
VPC 3240D	4H	✓	2	✓	DIGIT 3000
VPC 3241D		✓	2	✓	DIGIT 3000
VPC 3242D	4H	✓		✓	DIGIT 3000
VPC 3243D		✓		✓	DIGIT 3000
VPC 3205C	4H	✓			DIGIT 3000
VPC 3200A	2H	✓			DIGIT 3000
VPC 3201A		✓			DIGIT 3000

1.3. VPC Applications

Fig. 1–2 depicts several VPC applications. Since the VPC functions as a video front-end, it must be complemented with additional functionality to form a complete TV set.

The DDP 33x0 contains the video back-end with video postprocessing (contrast, peaking, DTI,...), H/V-deflection, RGB insertion (SCART, Text, PIP,...) and tube control (cutoff, white drive, beam current limiter). It generates a beam scan velocity modulation output from the digital YC_rC_b and RGB signals. Note that this signal is not generated from the external analog RGB inputs.

The component interface of the VPC 32xxD provides a high-quality analog RGB interface with character insertion capability. It also allows appropriate processing of external sources, such as MPEG2 set-top boxes in transparent (4:2:2) quality. Furthermore, it transforms RGB/Fast Blank signals to the common digital video bus and makes those signals available for 100-Hz up-conversion or double-scan processing. In some European countries (Italy), this feature is mandatory.

The IP indicates memory based image processing, such as scan rate conversion, vertical processing (Zoom), or PAL+ reconstruction. The VPC supports memory based applications through line-locked clocks, syncs and data. Additionally, the VPC323xD provides a 656-output interface and FIFO control signals.

Examples:

- Europe: 15 kHz/50 Hz → 32 kHz/100 Hz interlaced
- US: 15 kHz/60 Hz → 32 kHz/60 Hz non-interlaced

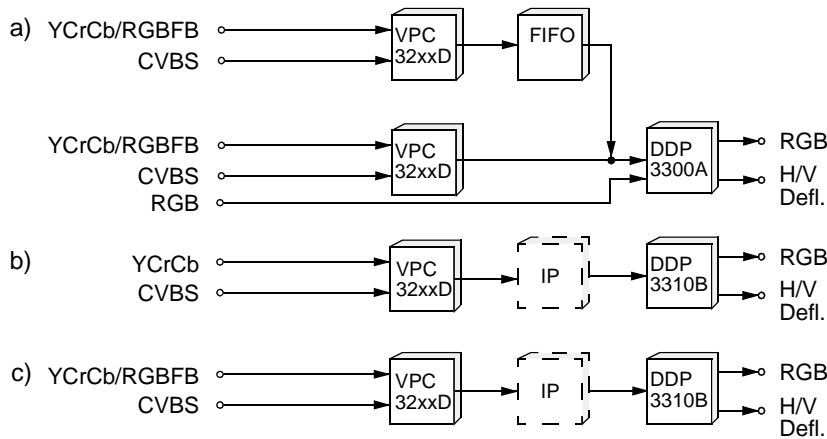

Fig. 1–2: VPC 32xxD applications

- a) 15 kHz application Europe
- b) double scan application (US, Japan) with YC_rC_b inputs
- c) 100 Hz application (Europe) with RGBFB inputs

2. Functional Description

2.1. Analog Video Front-End

This block provides the analog interfaces to all video inputs and mainly carries out analog-to-digital conversion for the following digital video processing. A block diagram is given in Fig. 2–1.

Most of the functional blocks in the front-end are digitally controlled (clamping, AGC, and clock-DCO). The control loops are closed by the Fast Processor ('FP') embedded in the decoder.

2.1.1. Input Selector

Up to five analog inputs can be connected. Four inputs are for composite video or S-VHS luma signal. These inputs are clamped to the sync back porch and are amplified by a variable gain amplifier. One input is for connection of S-VHS carrier-chrominance signal. This input is internally biased and has a fixed gain amplifier. A second S-VHS chroma signal can be connected video-input VIN1.

2.1.2. Clamping

The composite video input signals are AC coupled to the IC. The clamping voltage is stored on the coupling capacitors and is generated by digitally controlled current sources. The clamping level is the back porch of the video signal. S-VHS chroma is also AC coupled. The input pin is internally biased to the center of the ADC input range.

2.1.3. Automatic Gain Control

A digitally working automatic gain control adjusts the magnitude of the selected baseband by $+6/-4.5$ dB in 64 logarithmic steps to the optimal range of the ADC. The gain of the video input stage including the ADC is 213 steps/V with the AGC set to 0 dB.

2.1.4. Analog-to-Digital Converters

Two ADCs are provided to digitize the input signals. Each converter runs with 20.25 MHz and has 8 bit resolution. An integrated bandgap circuit generates the required reference voltages for the converters. The two ADCs are of a 2-stage subranging type.

2.1.5. Digitally Controlled Clock Oscillator

The clock generation is also a part of the analog front end. The crystal oscillator is controlled digitally by the control processor; the clock frequency can be adjusted within ± 150 ppm.

2.1.6. Analog Video Output

The input signal of the Luma ADC is available at the analog video output pin. The signal at this pin must be buffered by a source follower. The output voltage is 2 V, thus the signal can be used to drive a 75Ω line. The magnitude is adjusted with an AGC in 8 steps together with the main AGC.

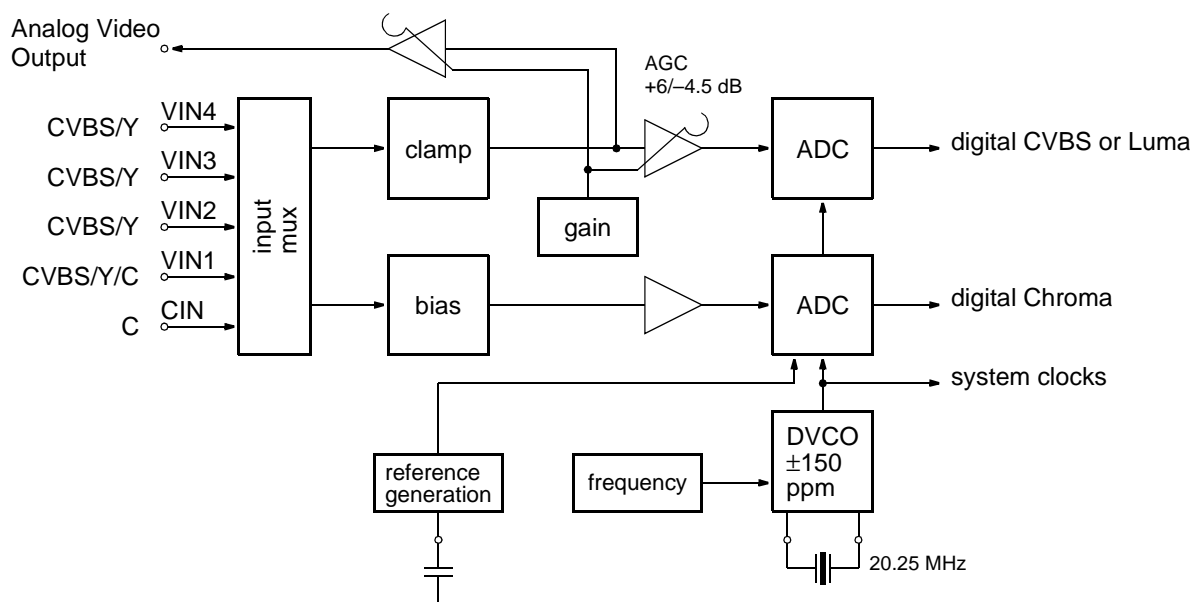

Fig. 2–1: Analog front-end

2.2. Adaptive Comb Filter

The 4H adaptive comb filter is used for high-quality luminance/chrominance separation for PAL or NTSC composite video signals. The comb filter improves the luminance resolution (bandwidth) and reduces interferences like cross-luminance and cross-color. The adaptive algorithm eliminates most of the mentioned errors without introducing new artifacts or noise.

A block diagram of the comb filter is shown in Fig. 2–2. The filter uses four line delays to process the information of three video lines. To have a fixed phase relationship of the color subcarrier in the three channels, the system clock (20.25 MHz) is fractionally locked to the color subcarrier. This allows the processing of all color standards and substandards using a single crystal frequency.

The CVBS signal in the three channels is filtered at the subcarrier frequency by a set of bandpass/notch filters. The output of the three channels is used by the adaption logic to select the weighting that is used to reconstruct the luminance/chrominance signal from the 4 bandpass/notch filter signals. By using soft mixing of the 4 signals switching artifacts of the adaption algorithm are completely suppressed.

The comb filter uses the middle line as reference, therefore, the comb filter delay is two lines. If the comb filter is switched off, the delay lines are used to pass the luma/chroma signals from the A/D converters to the luma/chroma outputs. Thus, the processing delay is always two lines.

In order to obtain the best-suited picture quality, the user has the possibility to influence the behaviour of the adaption algorithm going from moderate combing to strong combing. Therefore, the following three parameters may be adjusted:

- HDG (horizontal difference gain)
- VDG (vertical difference gain)
- DDR (diagonal dot reducer)

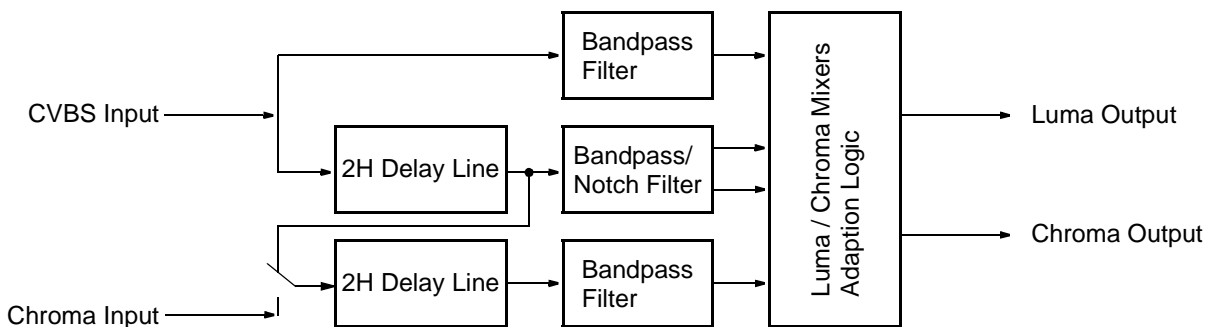

Fig. 2–2: Block diagram of the adaptive comb filter (PAL mode)

HDG typically defines the comb strength on horizontal edges. It determines the amount of the remaining cross-luminance and the sharpness on edges respectively. As HDG increases, the comb strength, e. g. cross luminance reduction and sharpness, increases.

VDG typically determines the comb filter behaviour on vertical edges. As VDG increases, the comb strength, e. g. the amount of hanging dots, decreases.

After selecting the combfilter performance in horizontal and vertical direction, the diagonal picture performance may further be optimized by adjusting DDR. As DDR increases, the dot crawl on diagonal colored edges is reduced.

To enhance the vertical resolution of the picture, the VPC provides a vertical peaking circuitry. The filter gain is adjustable between 0 – +6 dB and a coring filter suppresses small amplitudes to reduce noise artifacts. In relation to the comb filter, this vertical peaking widely contributes to an optimal two-dimensional resolution homogeneity.

2.3. Color Decoder

In this block, the standard luma/chroma separation and multi-standard color demodulation is carried out. The color demodulation uses an asynchronous clock, thus allowing a unified architecture for all color standards.

A block diagram of the color decoder is shown in Fig. 2–4. The luma as well as the chroma processing, is shown here. The color decoder also provides several special modes, e.g. wide band chroma format which is intended for S-VHS wide bandwidth chroma. Also, filter settings are available for processing a PAL+ helper signal.

If the adaptive comb filter is used for luma chroma separation, the color decoder uses the S-VHS mode processing. The output of the color decoder is Y_C, C_b in a 4:2:2 format.

2.3.1. IF-Compensation

With off-air or mistuned reception, any attenuation at higher frequencies or asymmetry around the color subcarrier is compensated. Four different settings of the IF-compensation are possible (see Fig. 2-3):

- flat (no compensation)
- 6 dB/octave
- 12 dB/octave
- 10 dB/MHz

The last setting gives a very large boost to high frequencies. It is provided for SECAM signals that are decoded using a SAW filter specified originally for the PAL standard.

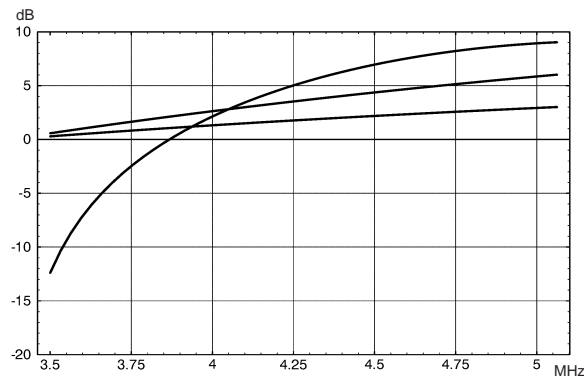

Fig. 2-3: Frequency response of chroma IF-compensation

2.3.2. Demodulator

The entire signal (which might still contain luma) is quadrature-mixed to the baseband. The mixing frequency is equal to the subcarrier for PAL and NTSC, thus achieving the chroma demodulation. For SECAM, the mixing frequency is 4.286 MHz giving the quadrature baseband components of the FM modulated chroma. After the mixer, a lowpass filter selects the chroma components; a downsampling stage converts the color difference signals to a multiplexed half rate data stream.

The subcarrier frequency in the demodulator is generated by direct digital synthesis; therefore, substandards such as PAL 3.58 or NTSC 4.43 can also be demodulated.

2.3.3. Chrominance Filter

The demodulation is followed by a lowpass filter for the color difference signals for PAL/NTSC. SECAM requires a modified lowpass function with bell-filter characteristic. At the output of the lowpass filter, all luma information is eliminated.

The lowpass filters are calculated in time multiplex for the two color signals. Three bandwidth settings (narrow, normal, broad) are available for each standard (see Fig. 2-5). For PAL/NTSC, a wide band chroma filter can be selected. This filter is intended for high bandwidth chroma signals, e.g. a nonstandard wide bandwidth S-VHS signal.

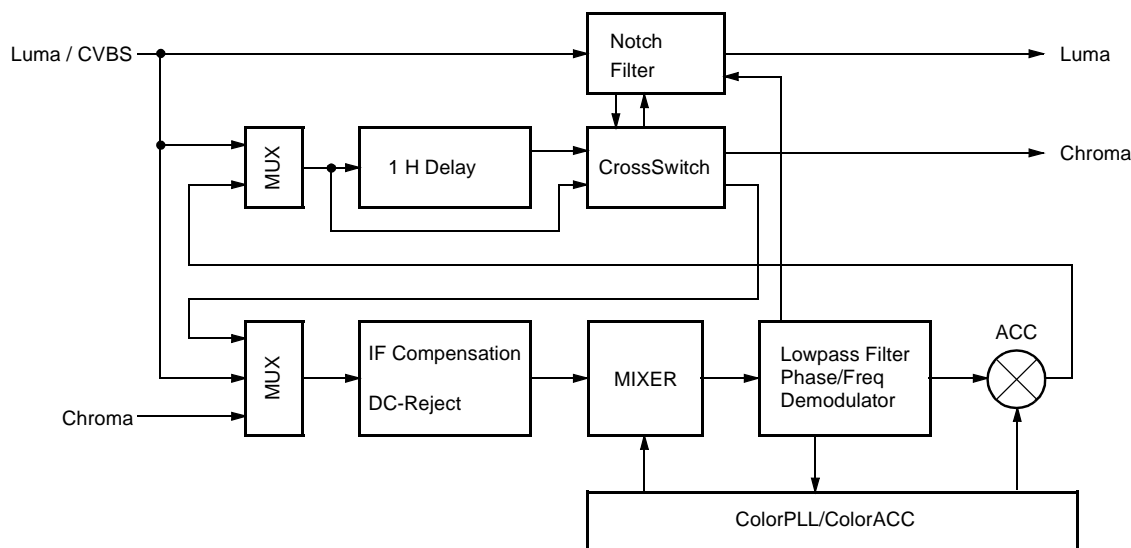

Fig. 2-4: Color decoder

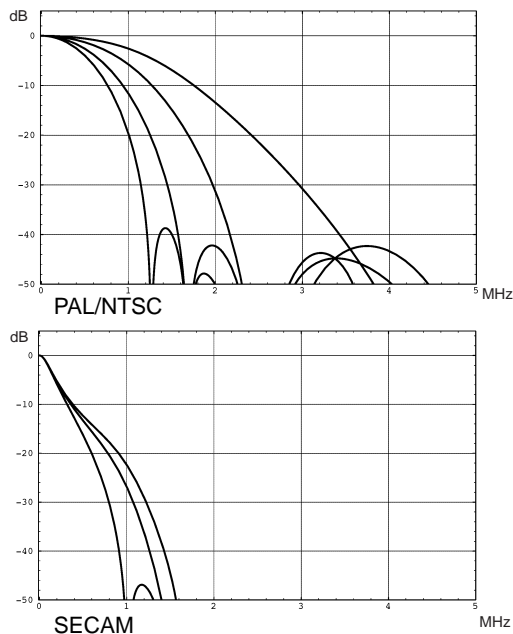

Fig. 2-5: Frequency response of chroma filters

2.3.4. Frequency Demodulator

The frequency demodulator for demodulating the SECAM signal is implemented as a CORDIC-structure. It calculates the phase and magnitude of the quadrature components by coordinate rotation.

The phase output of the CORDIC processor is differentiated to obtain the demodulated frequency. After the deemphasis filter, the D_r and D_b signals are scaled to standard $C_r C_b$ amplitudes and fed to the cross-over-switch.

2.3.5. Burst Detection / Saturation Control

In the PAL/NTSC-system the burst is the reference for the color signal. The phase and magnitude outputs of the CORDIC are gated with the color key and used for controlling the phase-lock-loop (APC) of the demodulator and the automatic color control (ACC) in PAL/NTSC.

The ACC has a control range of +30 ... -6 dB.

Color saturation can be selected once for all color standards. In PAL/NTSC it is used as reference for the ACC. In SECAM the necessary gains are calculated automatically.

For SECAM decoding, the frequency of the burst is measured. Thus, the current chroma carrier frequency can be identified and is used to control the SECAM processing. The burst measurements also control the

color killer operation; they are used for automatic standard detection as well.

2.3.6. Color Killer Operation

The color killer uses the burst-phase/burst-frequency measurement to identify a PAL/NTSC or SECAM color signal. For PAL/NTSC, the color is switched off (killed) as long as the color subcarrier PLL is not locked. For SECAM, the killer is controlled by the toggle of the burst frequency. The burst amplitude measurement is used to switch-off the color if the burst amplitude is below a programmable threshold. Thus, color will be killed for very noisy signals. The color amplitude killer has a programmable hysteresis.

2.3.7. Automatic standard recognition

The burst-frequency measurement is also used for automatic standard recognition (together with the status of horizontal and vertical locking) thus allowing a completely independent search of the line and color standard of the input signal. The following standards can be distinguished:

PAL B,G,H,I; NTSC M; SECAM; NTSC 44; PAL M; PAL N; PAL 60

For a preselection of allowed standards, the recognition can be enabled/disabled via I²C bus for each standard separately.

If at least one standard is enabled, the VPC32xxD checks regularly the horizontal and vertical locking of the input signal and the state of the color killer. If an error exists for several adjacent fields a new standard search is started. Depending on the measured line number and burst frequency the current standard is selected.

For error handling the recognition algorithm delivers the following status information:

- search active (busy)
- search terminated, but failed
- found standard is disabled
- vertical standard invalid

2.3.8. PAL Compensation/1-H Comb Filter

The color decoder uses one fully integrated delay line. Only active video is stored.

The delay line application depends on the color standard:

- NTSC: 1-H comb filter **or** color compensation
- PAL: color compensation
- SECAM: crossover-switch

In the NTSC compensated mode, Fig. 2-6 c), the color signal is averaged for two adjacent lines. Thus, cross-color distortion and chroma noise is reduced. In the NTSC 1-H comb filter mode, Fig. 2-6 d), the delay line is in the composite signal path, thus allowing reduction of cross-color components, as well as cross-luminance. The loss of vertical resolution in the luminance channel is compensated by adding the vertical detail signal with removed color information. If the 4H adaptive comb filter is used, the 1-H NTSC comb filter has to be deselected.

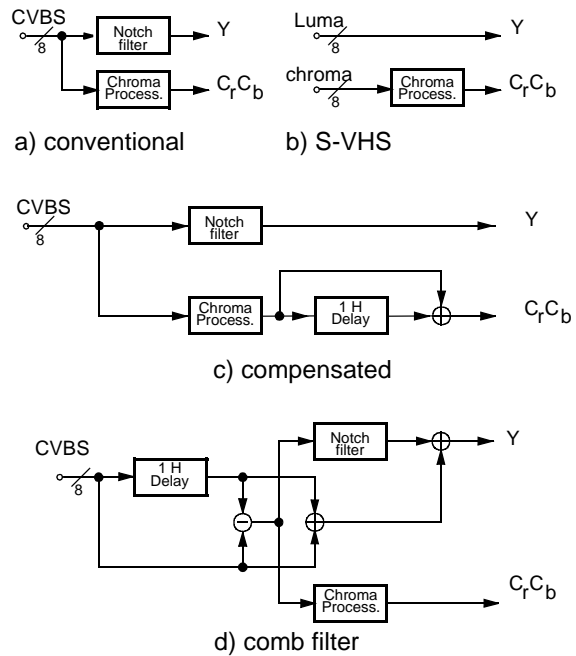

Fig. 2-6: NTSC color decoding options

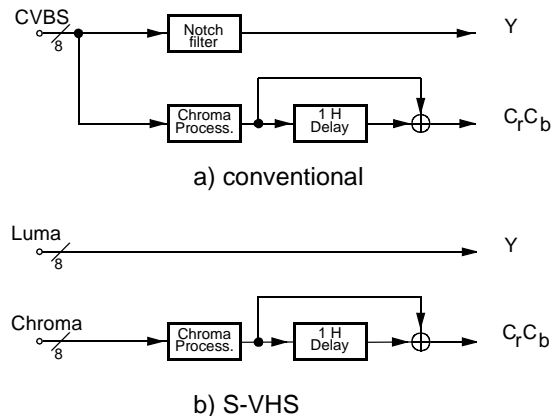

Fig. 2-7: PAL color decoding options

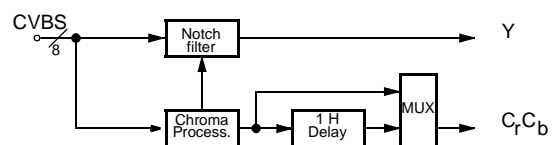
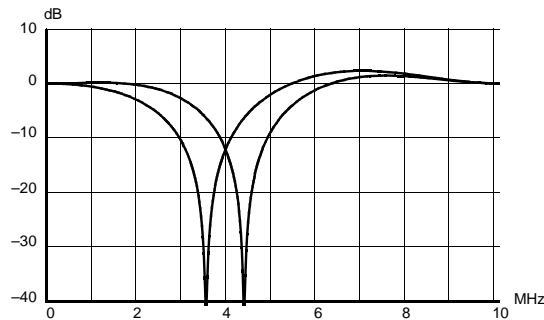

Fig. 2-8: SECAM color decoding

2.3.9. Luminance Notch Filter

If a composite video signal is applied, the color information is suppressed by a programmable notch filter. The position of the filter center frequency depends on the subcarrier frequency for PAL/NTSC. For SECAM, the notch is directly controlled by the chroma carrier frequency. This considerably reduces the cross-luminance. The frequency responses for all three systems are shown in Fig. 2–9.



PAL/NTSC notch filter

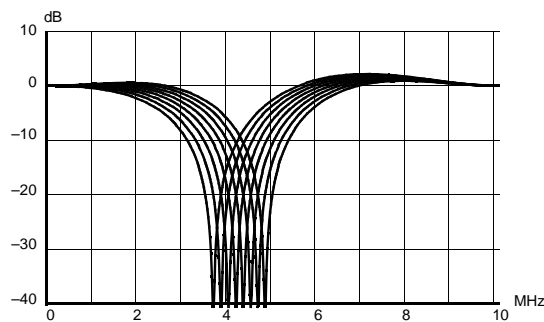

SECAM notch filter

Fig. 2–9: Frequency responses of the luma notch filter for PAL, NTSC, SECAM

2.3.10. Skew Filtering

The system clock is free-running and not locked to the TV line frequency. Therefore, the ADC sampling pattern is not orthogonal. The decoded Y_C, C_b signals are converted to an orthogonal sampling raster by the skew filters, which are part of the scaler block.

The skew filters are controlled by a skew parameter and allow the application of a group delay to the input signals without introducing waveform or frequency response distortion.

The amount of phase shift of this filter is controlled by the horizontal PLL1. The accuracy of the filters is 1/32 clocks for luminance and 1/4 clocks for chroma. Thus the 4:2:2 Y_C, C_b data is in an orthogonal pixel format even in the case of nonstandard input signals such as VCR.

2.4. Component Interface Processor CIP

This block (see Fig. 2–10) contains all the necessary circuitry dedicated to external analogue components (Y_C, C_b_{cip}) such as RGB or Y_C, C_b signals from DVD players, or other RGB sources with Fast Blank for real time insertion on the main picture (Y_C, C_b_{main}).

2.4.1. Component Analogue Front End

VPC 32xxD provides two analogue RGB/ Y_C, C_b input ports, one with Fast Blank capability and one without.

It is strongly recommended to use analogue 5 MHz anti-alias low-pass filters on each input, including FB. While all signals need to be capacitively coupled by 220 nF clamping capacitors, the Fast Blank input requires DC coupling.

The selected signal channel is further converted into a digital form by 3 high quality ADCs running at 20.25 MHz with a resolution of 8 bits. The FB input is digitized with a resolution of 6 bits.

Note: The VPC32xxD system synchronization always occurs through the main CVBS/Y ADC input. In any component mode, this input must therefore be handled accordingly.

2.4.2. Matrix

The RGB signals are converted to the Y_C, C_b format by a matrix operation:

$$\begin{aligned} Y &= 0.299R + 0.587G + 0.114B \\ (R-Y) &= 0.701R - 0.587G - 0.114B \\ (B-Y) &= -0.299R - 0.587G + 0.886B \end{aligned}$$

In case of Y_C, C_b input the matrix is bypassed.

2.4.3. Component Y_C, C_b Control

To guarantee optimum mixing results, various I²C programmable parameters are provided:

- $0 \leq \text{contrast} \leq 63/32$
- $-128 \leq \text{brightness} \leq 127$
- $0 \leq \text{saturation Cr} \leq 63/32$
- $0 \leq \text{saturation Cb} \leq 63/32$
- $-20 \leq \text{tint} \leq 20$ degrees

Table 2–1 gives the picture settings achieving exact level matching between the $YCrCb_{cip}$ and $YCrCb_{main}$ channel.

Table 2–1: Standard picture settings

input format	contrast	brightness	satCr	satCb
RGB	27	68	29	23
$YCrCb$	27	68	40	40

Note: $R, G, B, Cr, Cb = 0.7 V_{pp}, Y(+ \text{sync}) 1 V_{pp}$

2.4.4. Softmixer

After an automatic delay matching, the component signals and the upsampled main video signal are gathered onto a unique $YCrCb$ channel by means of a versatile 4:4:4 softmixer (see also Fig. 2–10).

The softmixer circuit consists of a Fast Blank (FB) processing block supplying a mixing factor k ($0..64$) to a high quality signal mixer achieving the output function:

$$YCrCb_{mix} = (k * YCrCb_{main} + (64 - k) * YCrCb_{cip}) / 64$$

The softmixer supports several basic modes that are selected via I²C bus (see Table 2–2).

2.4.4.1. Static Switch Mode

In its simplest and most common application the softmixer is used as a static switch between $YCrCb_{main}$ and $YCrCb_{cip}$. This is for instance the adequate way to handle a DVD component signal.

The factor k is clamped to 0 or 64, hence selecting $YCrCb_{main}$ or the component input $YCrCb_{cip}$. (see Table 2–2)

2.4.4.2. Static Mixer Mode

The signal $YCrCb_{main}$ and the component signal $YCrCb_{cip}$ may also be statically mixed. In this environment, k is manually controlled via I²C registers FBGAIN and FBOFFS according to the following expression:

$$k = FBGAIN * (31 - FBOFFS) + 32$$

All the necessary limitation and rounding operation are built-in to fit the range: $0 \leq k \leq 64$.

In the static mixer mode as well as in the previously mentioned static switch mode (see Table 2–2), the softmixer operates independently of the analogue Fast Blank input.

2.4.4.3. Dynamic Mixer Mode

In the dynamic mixer mode, the mixer is controlled by the Fast Blank signal. The VPC32xxD provides a linear mixing coefficient

$$k = kl = FBGAIN * (FB - FBOFFS) + 32$$

(FB is the digitized Fast Blank), and a non-linear mixing coefficient $knl = F(kl)$, which results from a further non-linear processing of kl .

While the linear mixing coefficient is used to insert a fullscreen video signal, the non-linear coefficient is well-suited to insert Fast Blank related signals like text.

The non-linear mixing reduces disturbing effects like over/undershoots at critical Fast Blank edges.

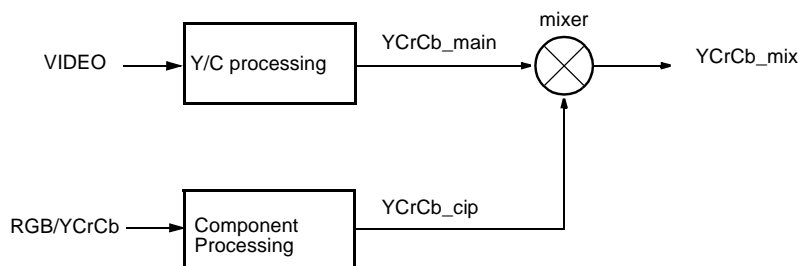

Fig. 2–10: Block diagram of the component mixer

Table 2–2: CIP softmixer modes

I ² C CIP mode	SELLIN	RGB DLY	FBCLP	FB MODE
Force Y _C C _b main	0	0	x	11
Force RGB/ Y _C C _b	0	0	x	x0
Static Mixer	0	0	1	01
FB Linear	0	0	0	01
FB non- Linear	1	1	0	01

2.4.5. 4:4:4 to 4:2:2 Downsampling

After the mixer, the 4:4:4 Y_CC_b_mix data stream is downsampled to the 4:2:2 format. For this sake, a chroma lowpass filter is provided to eliminate high-frequency components above 5-6 Mhz which may typically be present on inserted high resolution RGB/Y_CC_b sources.

In case of main video processing (loophrough) only, it is recommended to bypass this filter by using the I²C bit CIPCFBY.

2.4.6. Fast Blank and Signal Monitoring

The analogue Fast Blank state is monitored by means of four I²C readable bits. These bits may be used by the TV controller for SCART signal ident:

- FBHIGH: set by FB high, reset by register read at FB low
- FBSTAT: FB status at register read
- FBRISE: set by FB rising edge, reset by register read
- FBFALL: set by FB falling edge, reset by register read

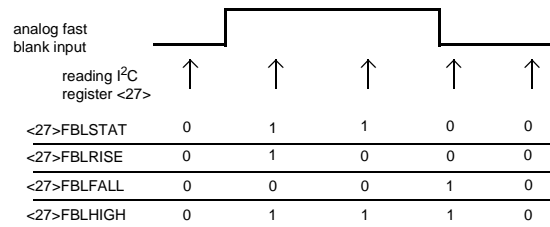

Fig. 2–11: Fast Blank Monitor

An additional monitoring bit is also provided for the RGB/Y_CC_b signal; it indicates whether the ADCs inputs are clipped or not. In case of clipping conditions (1Vpp RGB input for example) the ADC range can be extended by 3db by using the XAR bit.

- CLIPD: set by RGB/Y_CC_b input clip, reset by register read

2.5. Horizontal Scaler

The 4:2:2 Y_CC_b signal from the mixer output is processed by the horizontal scaler. It contains a lowpass-filter, a prescaler, a scaling engine and a peaking filter. The scaler block allows a linear or nonlinear horizontal scaling of the input signal in the range of 1/32 to 4. Nonlinear scaling, also called “panorama vision”, provides a geometrical distortion of the input picture. It is used to fit a picture with 4:3 format on a 16:9 screen by stretching the picture geometry at the borders. Also, the inverse effect - called water glass - can be produced by the scaler. A summary of scaler modes is given in Table 2–3.

2.5.1. Horizontal Lowpass-filter

The luma filter block applies anti-aliasing lowpass filters. The cutoff frequencies are selectable and have to be adapted to the horizontal scaling ratio.

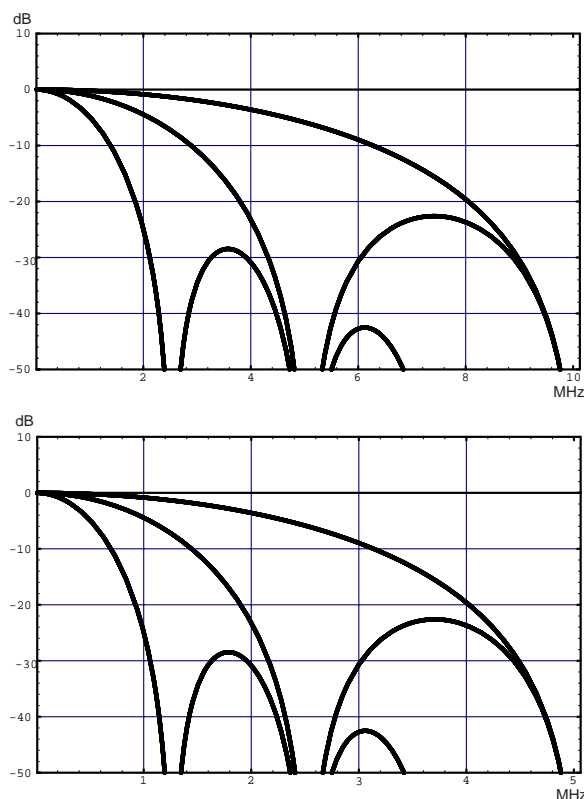

Fig. 2–12: $YCrCb$ downsampling lowpass-filter

2.5.2. Horizontal Prescaler

To achieve a horizontal compression ratio between 1/4 and 1/32 (e. g. for double window or PIP operation) a linear downsampler resamples the input signal by 1 (no presampling), 2, 4 and 8.

2.5.3. Horizontal Scaling Engine

The scaler contains a programmable decimation filter, a 1-H FIFO memory, and a programmable interpolation filter. The scaler input filter is also used for pixel skew correction, see 2.3.10. The decimator/interpolator structure allows optimal use of the FIFO memory. It allows a linear or nonlinear horizontal scaling of the input video signal in the range of 0.25 to 4. The controlling of the scaler is done by the internal Fast Processor.

Table 2–3: Scaler modes

Mode	Scale Factor	Description
Compression 4:3 → 16:9	0.75 linear	4:3 source displayed on a 16:9 tube, with side panels
Panorama 4:3 → 16:9	non-linear compr	4:3 source displayed on a 16:9 tube, Borders distorted
Zoom 4:3 → 4:3	1.33 linear	Letterbox source (PAL+) displayed on a 4:3 tube, vertical overscan with cropping of side panels
Water glass 16:9 → 4:3	non-linear zoom	Letterbox source (PAL+) displayed on a 4:3 tube, vertical overscan, borders distorted, no cropping
20.25 → 13.5 MHz	0.66	sample rate conversion to line-locked clock

2.5.4. Horizontal Peaking-filter

The horizontal scaler block offers an extra peaking filter for sharpness control. The center frequency of the peaking filter automatically adopts to the horizontal scaling ratio. Three center frequencies are selectable (see Fig. 2–13:)

- center at sampling rate / 2
- center at sampling rate / 4
- center at sampling rate / 6

The filter gain is adjustable between 0 – +10 dB and a coring filter suppresses small amplitudes to reduce noise artifacts.

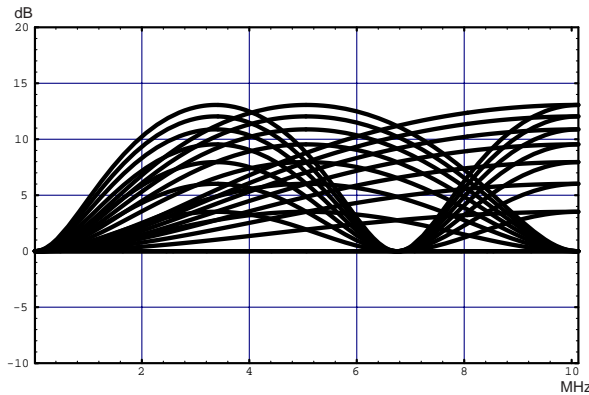

Fig. 2-13: Peaking characteristics

2.6. Vertical Scaler

For PIP operation, the vertical scaler compresses the incoming 4:2:2 Y_C, C_b active video signal in vertical direction. It supports a vertical compression ratio of 1 (= no compression), 2, 3, 4 and 6.

In case of a vertical compression of 2, 4 and 6, the filter performs the PAL compensation automatically and the standard PAL delay line should be bypassed (see 2.3.8.).

2.7. Contrast and Brightness

The VPC32xxD provides a selectable contrast and brightness adjustment for the luma samples. The control ranges are:

- $0 \leq \text{contrast} \leq 63/32$
- $-128 \leq \text{brightness} \leq 127$

Note: for ITU-R luma output code levels (16 ... 240), contrast has to be set to 48 and brightness has to be set to 16!

2.8. Blackline Detector

In case of a letterbox format input video, e.g. Cinemascope, PAL+ etc., black areas at the upper and lower part of the picture are visible. It is suitable to remove or reduce these areas by a vertical zoom and/or shift operation.

The VPC 32xx supports this feature by a letterbox detector. The circuitry detects black video lines by measuring the signal amplitude during active video. For every field the number of black lines at the upper and lower part of the picture are measured, compared to the previous measurement and the minima are stored in the I²C-register BLKLIN. To adjust the picture

amplitude, the external controller reads this register, calculates the vertical scaling coefficient and transfers the new settings, e.g. vertical sawtooth parameters, horizontal scaling coefficient etc., to the VPC.

Letterbox signals containing logos on the left or right side of the black areas are processed as black lines, while subtitles, inserted in the black areas, are processed as non-black lines. Therefore the subtitles are visible on the screen. To suppress the subtitles, the vertical zoom coefficient is calculated by selecting the larger number of black lines only. Dark video scenes with a low contrast level compared to the letterbox area are indicated by the BLKPIC bit.

2.9. Control and Data Output Signals

The VPC 32xx supports two output modes: In DIGIT3000 mode, the output interfaces run at the main system clock, in line-locked mode, the VPC generates an asynchronous line-locked clock that is used for the output interfaces. The VPC delivers either a Y_C, C_b 4:2:2 or a Y_C, C_b 4:1:1 data stream, each with separate sync information. In case of Y_C, C_b 4:2:2 format, the VPC32xxD also provides an interface with embedded syncs according to ITU-R656.

2.9.1. Line-Locked Clock Generation

An on-chip rate multiplier is used to synthesize any desired output clock frequency of 13.5/16/18 MHz. A double clock frequency output is available to support 100 Hz systems. The synthesizer is controlled by the embedded RISC controller, which also controls all front-end loops (clamp, AGC, PLL1, etc.). This allows the generation of a line-locked output clock regardless of the system clock (20.25 MHz) which is used for comb filter operation and color decoding. The control of scaling and output clock frequency is kept independent to allow aspect ratio conversion combined with sample rate conversion. The line-locked clock circuitry generates control signals, e.g. horizontal/vertical sync, active video output, it is also the interface from the internal (20.25 MHz) clock to the external line-locked clock system.

If a line-locked clock is not required, i.e. in the DIGIT3000 mode, the system runs at the 20.25 MHz main clock. The horizontal timing reference in this mode is provided by the front-sync signal. In this case, the line-locked clock block and all interfaces run from the 20.25 MHz main clock. The synchronization signals from the line-locked clock block are still available, but for every line the internal counters are reset with the main-sync signal. A double clock signal is not available in DIGIT3000 mode.

2.9.2. Sync Signals

The front end will provide a number of sync/control signals which are output with the output clock. The sync signals are generated in the line-locked clock block.

- Href: horizontal sync
- AVO: active video out (programmable)
- HC: horizontal clamp (programmable)
- Vref: vertical sync
- INTLC: interlace

All horizontal signals are not qualified with field information, i.e. the signals are present on all lines. The horizontal timing is shown in Fig. 2–16. Details of the horizontal/vertical timing are given in Fig. 2–20.

Note: In the ITU-R656 compliant output format, the sync information is embedded in the data stream.

2.9.3. DIGIT3000 Output Format

The picture bus format between all DIGIT3000 ICs is 4:2:2 Y_C, C_b with 20.25 MHz samples/s. Only active video is transferred, synchronized by the system main sync signal (MSY) which indicates the start of valid data for each scan line and which initializes the color multiplex. The video data is orthogonally sampled Y_C, C_b , the output format is given in Table 2–4. The number of active samples per line is 1080 for all standards (525 and 625).

The output can be switched to 4:1:1 mode with the output format according to Table 2–5.

Via the MSY line, serial data is transferred which contains information about the main picture such as current line number, odd/even field etc.). It is generated by the deflection circuitry and represents the orthogonal timebase for the entire system.

Table 2–4: Orthogonal 4:2:2 output format

Luma	Y_1	Y_2	Y_3	Y_4
Chroma	C_{b1}	C_{r1}	C_{b3}	C_{r3}

2.9.4. Line-Locked 4:2:2 Output Format

In line-locked mode, the VPC 32xx will produce the industry standard pixel stream for Y_C, C_b data. The difference to DIGIT3000 native mode is only the number of active samples, which of course, depends on the chosen scaling factor. Thus, Table 2–4 is valid for both 4:2:2 modes.

2.9.5. Line-Locked 4:1:1 Output Format

The orthogonal 4:1:1 output format is compatible to the industry standard. The Y_C, C_b samples are skew-corrected and interpolated to an orthogonal sampling raster (see Table 2–5).

Table 2–5: 4:1:1 Orthogonal output format

Luma Chroma	Y_1	Y_2	Y_3	Y_4
C_3, C_7	C_{b1}^7	C_{b1}^5	C_{b1}^3	C_{b1}^1
C_2, C_6	C_{b1}^6	C_{b1}^4	C_{b1}^2	C_{b1}^0
C_1, C_5	C_{r1}^7	C_{r1}^5	C_{r1}^3	C_{r1}^1
C_0, C_4	C_{r1}^6	C_{r1}^4	C_{r1}^2	C_{r1}^0

note: C_x^y (x = pixel number and y = bit number)

2.9.6. ITU-R 656 Output Format

This interface uses a Y_C, C_b 4:2:2 data stream at a line-locked clock of 13.5 MHz. Luminance and chrominance information is multiplexed to 27 MHz in the following order:

$$C_{b1}, Y_1, C_{r1}, Y_2, \dots$$

Timing reference codes are inserted into the data stream at the beginning and the end of each video line:

- a 'Start of active video'-Header (SAV) is inserted before the first active video sample
- a 'End of active video'-code (EAV) is inserted after the last active video sample.

The incoming videostream is limited to a range of 1...254 since the data words 0 and 255 are used for identification of the reference headers. Both headers contain information about the field type and field blanking. The data words occurring during the horizontal blanking interval between EAV and SAV are filled with 0x10 for luminance and 0x80 for chrominance information. Table 2–6 shows the format of the SAV and EAV header.

For activation of this output format, the following selections must be assured:

- 13.5 MHz line locked clock
- double-clock mode enabled
- ITU-R656-mode enabled
- binary offset for Cr/Cb data

Note that the following changes and extensions to the ITU-R656 standard have been included to support horizontal and vertical scaling:

- Both the length and the number of active video lines varies with the selected window parameters. For compliance with the ITU-R656 recommendation, a size of 720 samples per line must be selected for each window.
- During blanked video lines SAV/EAV headers are suppressed in pairs. To assure vertical sync detection the V-flag in the EAV header of the last active video line is set to 1. Additionally, during field blanking all SAV/EAV headers (with the V-flag set to 1) are inserted.

Table 2-6: Coding of the SAV/EAV-header

Word	Bit No.							
	MSB				LSB			
	7	6	5	4	3	2	1	0
First	1	1	1	1	1	1	1	1
Second	0	0	0	0	0	0	0	0
Third	0	0	0	0	0	0	0	0
Fourth	T	F	V	H	P3	P2	P1	P0

F = 0 during field 1, F = 1 during field 2
 V = 0 during active lines V = 1 during vertical field blanking
 H = 0 in SAV, H = 1 in EAV
 T = 1 (video task only)

The bits P0, P1, P2, and P3 are Hamming-coded protection bits.

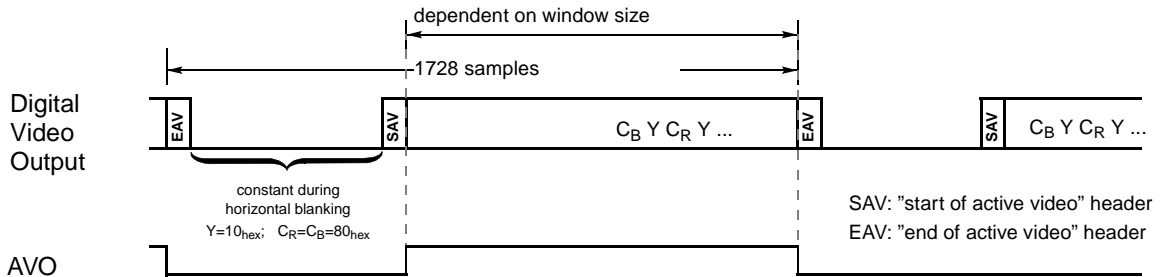

Fig. 2-14: Output of video data with embedded reference headers (@27 MHz)

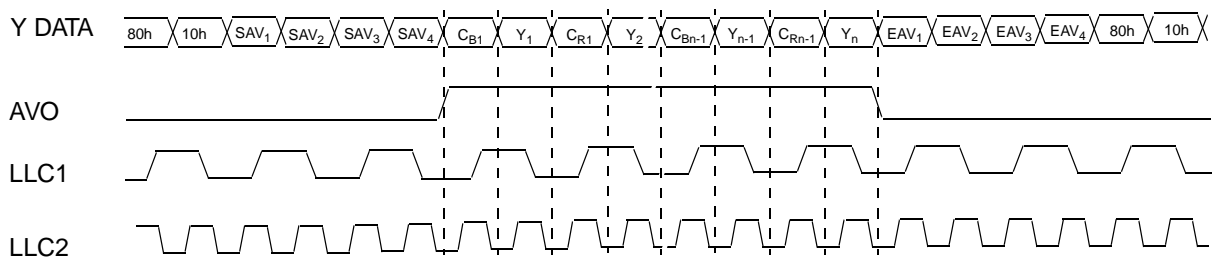

Fig. 2-15: Detailed data output (double-clock on)

Table 2–7: Output signals corresponding to the different formats

Format	dbclk	enable656	HSync	VSync	AVO	Y-Data	C-Data
16 bit Y _{C_rC_b} 422	0	0	PAL/NTSC	PAL/NTSC	marks active pixels	4:2:2	4:2:2
8 bit Y _{C_rC_b} 422	1	0	PAL/NTSC	PAL/NTSC	marks active pixels	4:2:2	tristated
ITU-R 656	1	1	not used	not used	not used	ITU-R 656	tristated

The multiplex of luminance and chrominance information and the embedding of 656-headers can be enabled independently. An overview of the resulting output formats and the corresponding signals is given in Table 2–7.

2.9.7. Output Code Levels

Output Code Levels correspond to ITU-R code levels:
 $Y = 16...240$
 Black Level = 16
 $C_r C_b = 128 \pm 112$
 An overview over the output code levels is given in Table 2–8.

2.9.8. Output Ports

All data and sync pins operate at TTL compliant levels and can be tristated via I²C registers.

Additionally, the data outputs can be tristated via the \overline{YCOE} output enable pin immediately. This function allows the digital insertion of a 2nd digital video source (e. g. MPEG aso.).

To minimize crosstalk data and clock pins automatically adopt the output driver strength depending on their specific external load (max. 50pF). Sync and Fifo control pins have to be adjusted manually via an I²C register.

2.9.9. Test Pattern Generator

The Y_{C_rC_b} outputs can be switched to a test mode where Y_{C_rC_b} data are generated digitally in the VPC32xx. Test patterns include luma/chroma ramps, flat field and a pseudo color bar.

2.10. PAL+ Support

For PAL+, the VPC 323xD provides basic helper pre-processing:

- A/D conversion (shared with the existing ADCs)
- mixing with subcarrier frequency
- lowpass filter 2.5 MHz
- gain control by chroma ACC
- delay compensation to composite video path
- output at the luma output port

Helper signals are processed like the main video luma signals, i.e. they are subject to scaling, sample rate conversion and orthogonalization if activated. The adaptive comb filter processing is switched off for the helper lines.

It is expected that further helper processing (e.g. non-linear expansion, matched filter) is performed outside the VPC.

2.10.1. Output Signals for PAL+/Color+ Support

For a PAL+/Color+ signal, the 625 line PAL image contains a 16/9 core picture of 431 lines which is in standard PAL format. The upper and lower 72 lines contain the PAL+ helper signal, and line 23 contains signalling information for the PAL+ transmission.

For PAL+ mode, the Y signal of the core picture, which is during lines 60–274 and 372–586, is replaced by the orthogonal composite video input signal. In order to fit the signal to the 8-bit port width, the ADC signal amplitudes are used. During the helper window, which is in lines 24–59, 275–310, 336–371, 587–622, the demodulated helper is signal processed by the horizontal scaler and the output circuitry. It is available at the luma output port. The processing in the helper reference lines 23 and 623 is different for the wide screen signaling part and the black reference and helper burst signals. The code levels are given in detail in Table 2–8, the output signal for the helper reference line is shown in Fig. 2–17.

Table 2–8: Output signal code levels for a PAL/PAL+ signal

Output Signal	Luma Outputs Y[7:0]			Chroma Outputs C[7:0]	
	Output Format	Black/Zero Level	Amplitude	Output Format	Amplitude
Standard YC _r C _b (100% Chroma)	binary	16	224	offset binary	128±112
				signed	±112
CVBS, CrCb	binary	64	149 (luma)	offset binary	128±112
				signed	±112
Demodulated Helper	signed	0	±109	–	–
Helper WSS	binary	68	149 (WSS:106)	–	–
Helper black level, Ref. Burst	offset binary	128	19 (128–109)	–	–

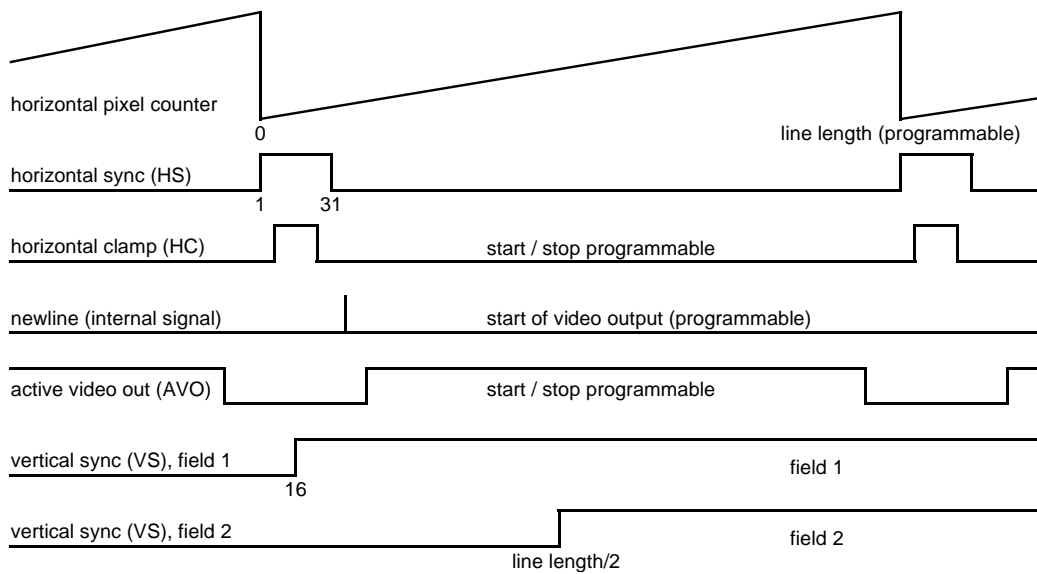

Fig. 2–16: Horizontal timing for line-locked mode

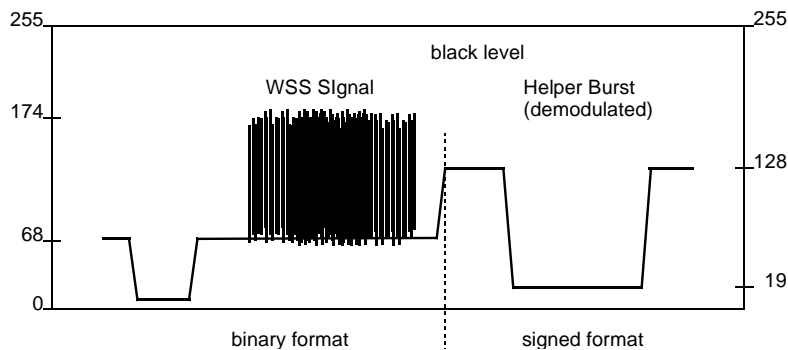

Fig. 2–17: PAL+ helper reference line output signal

2.11. Video Sync Processing

Fig. 2–18 shows a block diagram of the front-end sync processing. To extract the sync information from the video signal, a linear phase lowpass filter eliminates all noise and video contents above 1 MHz. The sync is separated by a slicer; the sync phase is measured. A variable window can be selected to improve the noise immunity of the slicer. The phase comparator measures the falling edge of sync, as well as the integrated sync pulse.

The sync phase error is filtered by a phase-locked loop that is computed by the FP. All timing in the front-end is derived from a counter that is part of this PLL, and it thus counts synchronously to the video signal.

A separate hardware block measures the signal back porch and also allows gathering the maximum/minimum of the video signal. This information is processed by the FP and used for gain control and clamping.

For vertical sync separation, the sliced video signal is integrated. The FP uses the integrator value to derive vertical sync and field information.

The information extracted by the video sync processing is multiplexed onto the hardware front sync signal (FSY) and is distributed to the rest of the video processing system. The format of the front sync signal is given in Fig. 2–19.

The data for the vertical deflection, the sawtooth, and the East-West correction signal is calculated by the VPC 32xx. The data is buffered in a FIFO and transferred to the back-end IC DDP 3300A by a single wire interface.

Frequency and phase characteristics of the analog video signal are derived from PLL1. The results are fed to the scaler unit for data interpolation and orthogonalization and to the clock synthesizer for line-locked clock generation. Horizontal and vertical syncs are latched with the line-locked clock.

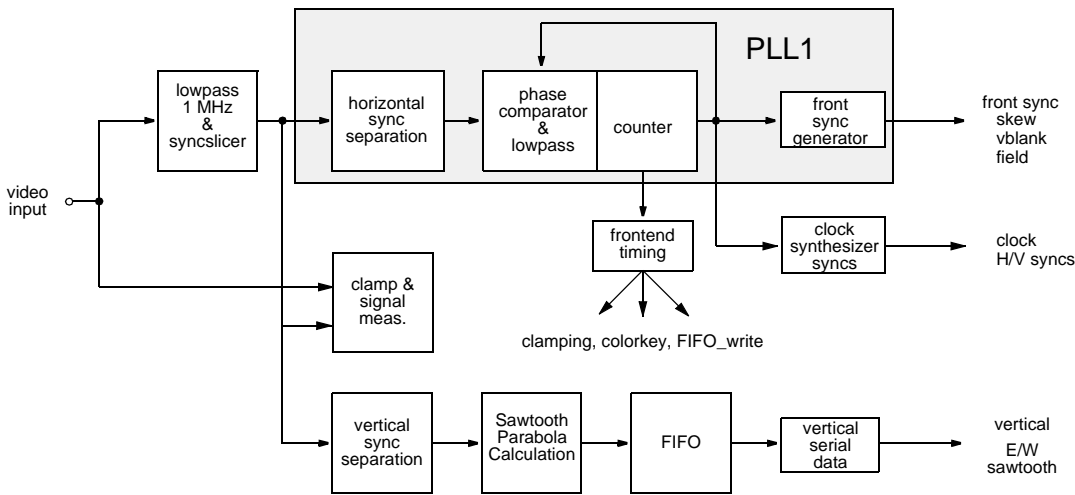

Fig. 2–18: Sync separation block diagram

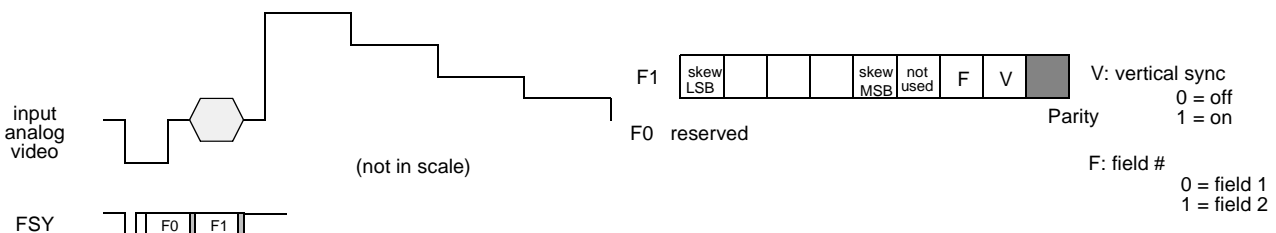
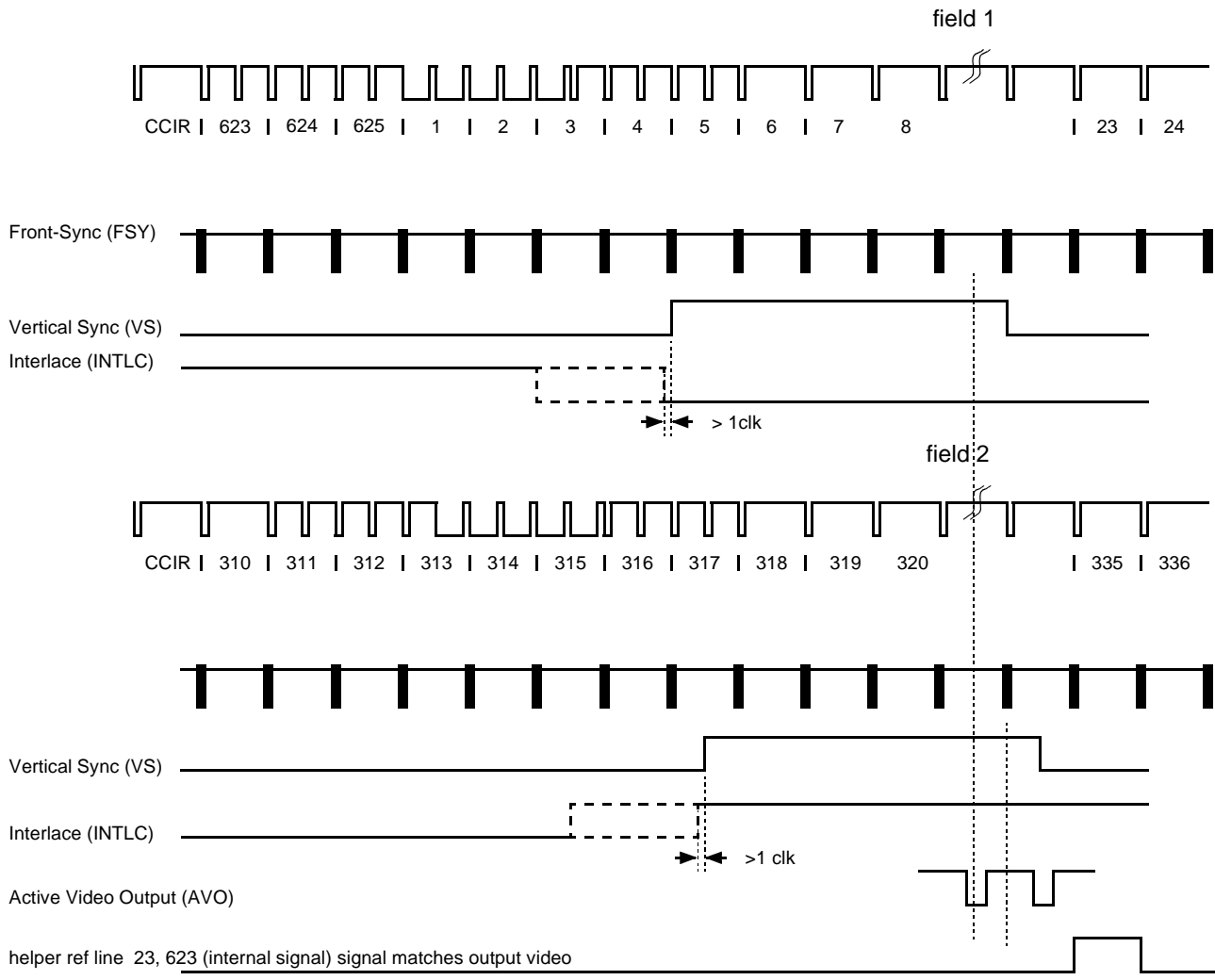

Fig. 2–19: Front sync format



The following signals are identical for field1 / field2

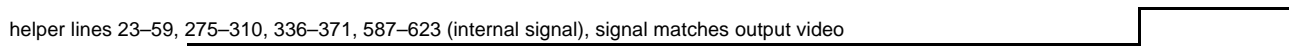

Fig. 2-20: Vertical timing of VPC 32xxD shown in reference to input video. Video output signals are delayed by 3-h for comb filter version (VPC 32xxD).

2.12. Picture in Picture (PIP) Processing and Control

2.12.1. Configurations

To support PIP and/or scan rate conversion (SRC) applications, the VPC32xxD provides several control signals for an external field memory IC.

Fig. 2–21 demonstrates two applications with a single VPC 32xxD. In these cases the VPC_{single} writes the main picture or one of several inset picture(s) into the field memory. Only one of these pictures is displayed

live. These configurations are suitable for features such as turner scan, still picture, still in picture and simple scan rate conversion.

Fig. 2–22 shows an enhanced configuration with two VPC 32xxD's. In this case, one live and several still pictures are inserted into the main live video signal. The VPC_{pip} processes the inset picture and writes the original or decimated picture into the field memory. The VPC_{main} delivers the main picture, combines it with the inset picture(s) from the field memory and stores the combined video signal into a second field memory for the SRC.

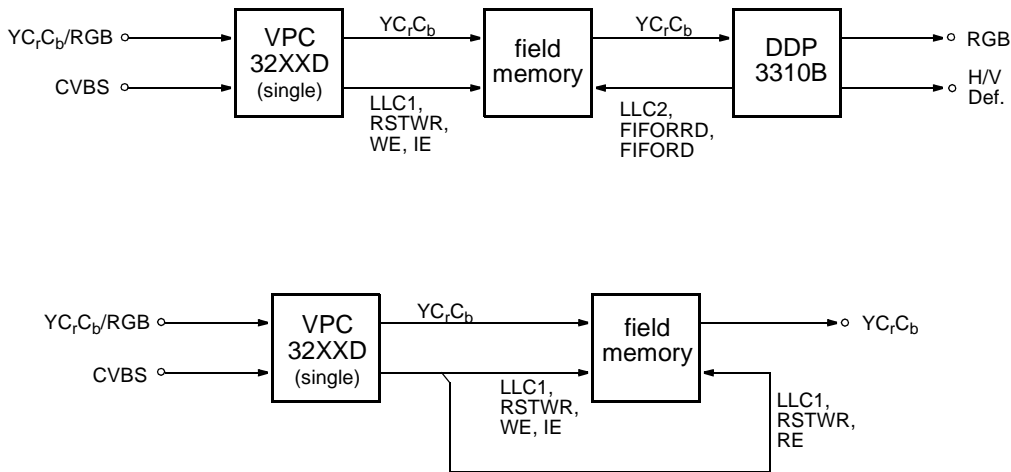

Fig. 2–21: Typical configurations with single VPC 32xxD

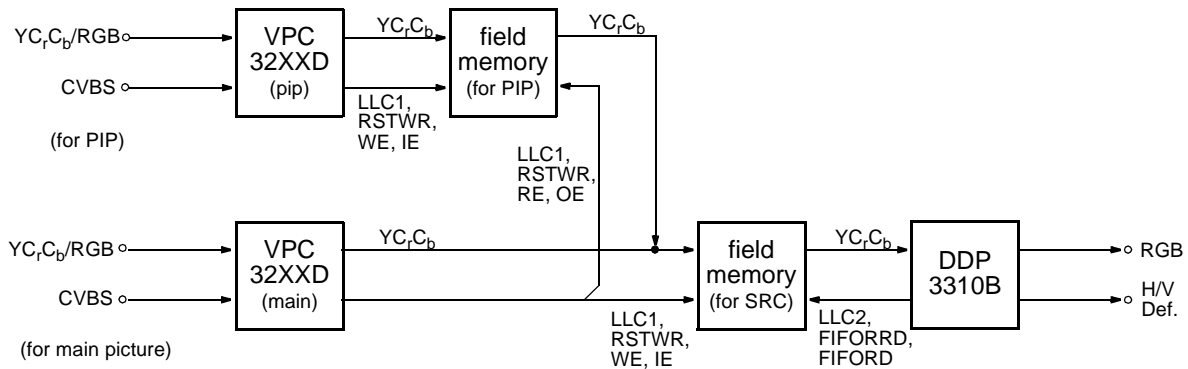

Fig. 2–22: Enhanced configuration with two VPC 32xxD

A summary of VPC modes is given in Table 2–9.

Table 2–9: VPC 32xxD modes for PIP applications

Working mode	Function
pip	<ul style="list-style-type: none"> - decimate the video signal for the inset pictures - write the inset pictures into the field memory - write the frame and background into the field memory
main	<ul style="list-style-type: none"> - deliver the video signal for the main picture - read the inset pictures from the field memory and insert them into the main picture - write the resulting video signal into the field memory for the scan rate conversion (SRC)
single	<ul style="list-style-type: none"> - decimate the video signal for the main or the inset picture(s) - write the inset pictures into the field memory - write the frame and background into the field memory - write the main picture part outside the inset pictures into the field memory - read the field memory (optional)

2.12.2. PIP Display Modes

To minimize the programming effort, 15 predefined PIP modes are already implemented, including double windows, single and multi-PIP (Fig. 2–23 and 2–24).

Table 2–11: Scaler Settings for predefined PIP modes at 13.5 MHz

PIP size	scinc1 FP h'43	fflim FP h'42	sc-pip FP h'41	sc_bri ²⁾ FP h'52	newlin ¹⁾ I ² C h'22	avstrt ¹⁾ I ² C h'28	avstop I ² C h'29
full	h'600	h'2d0	h'00	h'010	h'86	h'86	h'356
1/2	h'600	h'168	h'11	h'110	h'194	h'86	h'356
1/3	h'480	h'f0	h'16	h'210	h'194	h'86	h'356
1/4	h'600	h'b4	h'1a	h'210	h'194	h'86	h'356
1/6	h'480	h'78	h'1f	h'310	h'194	h'86	h'356
dou. win	h'acd	h'190	h'00	h'010	h'86	h'86	h'356

- Notes: 1) must be > 47, if FIFOTYPE=0 or 1
 2) BR=16 in register sc_bri
 3) MSB of SC_MODE updates all scaler register

In addition an expert mode is available for advanced PIP applications. In this case the inset picture size, as well as the PIP window arrangements are fully programmable.

Examples for the PIP mode programming are given in 5.2.

2.12.3. Predefined Inset Picture Size

The predefined PIP display modes are based on four fixed inset picture sizes (see Table 2–10). The corresponding picture resizing is achieved by the integrated horizontal and vertical scaler of VPC 32xxD, which must be programmed accordingly (see Table 2–11).

The inset pictures are displayed with or without a frame controlled by I²C. The fixed frame width is 4 pixels and 4 lines..

Table 2–10: Inset picture size (without frame) in the predefined PIP modes

size	horizontal [pixel/line]				vertical [line/field]	
	4:3 screen		16:9 screen		625 line	525 line
	13.5 MHz	16 MHz	13.5 MHz	16 MHz		
1/2	332	392	248	292	132	110
1/3	220	260	164	196	88	74
1/4	164	196	124	148	66	55
1/6	112	132	84	96	44	37

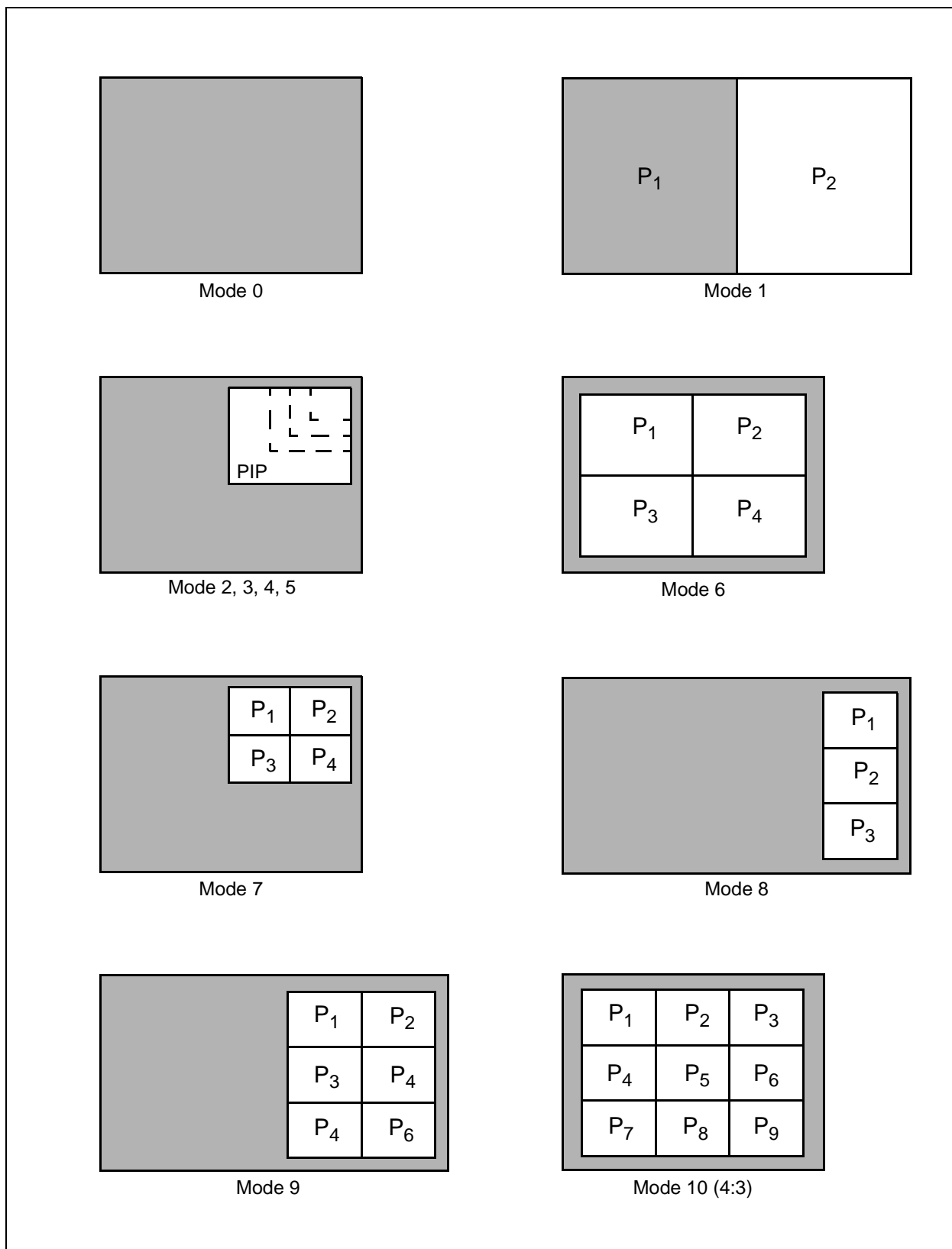

Fig. 2-23: Predefined PIP Modes

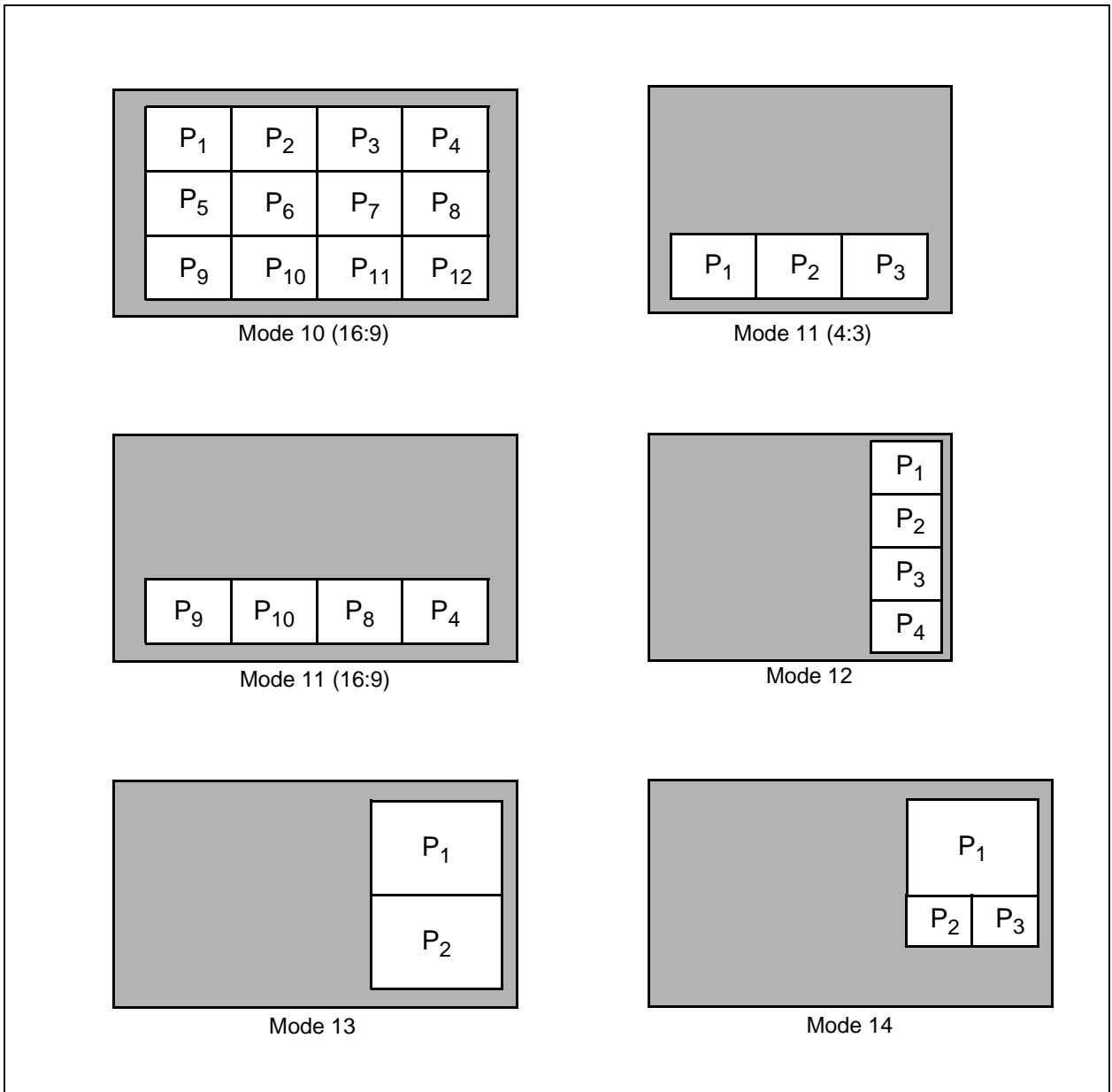

Fig. 2-24: Predefined PIP Modes (continued)

2.12.4. Acquisition and Display Window

The acquisition window defines the picture area of the input active video to be displayed as a inset picture on the screen.

The display window defines the display position of the inset picture(s) on the screen.

The acquisition and display windows are controlled by I²C parameters HSTR, VSTR, NPIX and NLIN (see Fig. 2–25 and 2–26). They indicate the coordinate of the upper-left corner and the horizontal and vertical size of the active video area. In VPC_{pip} or VPC_{single} mode, these four parameters define the acquisition window in the decimated pixel grid, while in VPC_{main} mode they define the display window.

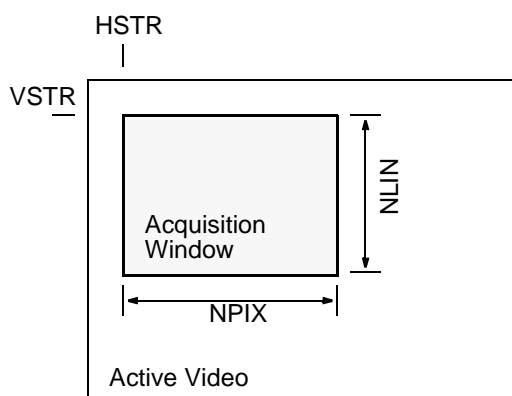

Fig. 2–25: Definition of the acquisition window

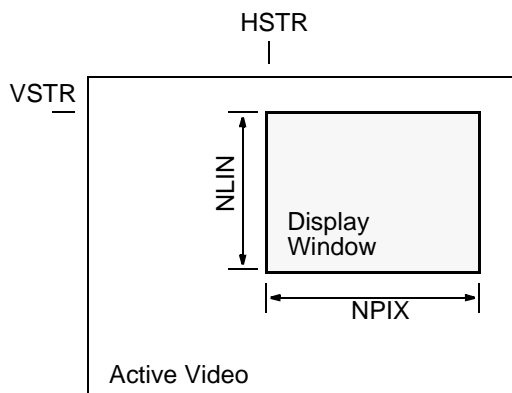

Fig. 2–26: Definition of the display window

2.12.5. Frame and Background Color

Two programmable frame colors COLFR1 and COLFR2 are available to high-light a particular inset picture.

Instead of displaying the main picture it is possible to fill the background with a programmable color COLBGD (set SHOWBGD=1 in the register PIPMODE), e. g. for multi PIP displays on the full screen (see mode 6 and 10).

COLFR1, COLFR2 and COLBGD are 16 bits wide each. Therefore 65536 colors are programmable.

2.12.6. Vertical Shift of the Main Picture

The VPC_{main} mode supports vertical up-shifting of the main picture (e. g. letterbox format) to enable bottom insets (see mode 11). The vertical shift is programmable by VOFFSET.

2.12.7. Free Running Display Mode

In this mode a free running sync raster is generated to guarantee a stable display in critical cases like tuner scan. Therefore the LLC should be disabled (see Table 2–12).

2.12.8. Frame and Field Display Mode

In frame display mode, every field is written into the field memory. In the field display mode every second field is written into the field memory. This configuration is suitable for multi picture insets and freeze mode, since it avoids motion artifacts. On the other hand, the frame display mode guarantees maximum vertical and temporal resolution for animated insets.

In the predefined mode the setting of frame/field mode is done automatically to achieve the best performance.

Table 2–12: Settings for Free-Running Mode

Control bit	Function	VPC _{single}		VPC _{pip}	VPC _{main}	
		write PIP	write main pic.		predef. mode 6, 10	all other modes
bit[11] of LLC_CLKC (FP h'6a)	enable/disable LLC PLL	1	0	0	1	0
bit[15] of AVO START (I ² C h'28)	enable/disable free-running sync mode	1	0	0	1	0

2.12.9. External Field Memory

The requirements of the external field memory are:

- FIFO type access with reset
- write mask function: The increasing of the write address pointer and the over writing of the data should be controlled separately.
- output disable function: tri-statetable outputs

As serial write and serial read clock (**SWCK** and **SRCK**, respectively) of the field memory the line locked clocks LLC1 and/or LLC2 are used.

For PIP applications, VPC 32xxD supports 4:1:1 or 4:2:2 chrominance format. Table 2–13 shows the typical memory size for a 13.5 and 16 MHz system clock application.

Table 2–13: Word length and minimum size of the field memory

Chrominance format	Word length [bit]	Memory size	
		[word]	[bit]
4:1:1	12	245376	2944512
4:2:2	16	245376	3926016

The following 5 signals are generated by VPC 32xxD to control the external field memory:

RSTWR (reset write/read) resets the internal write/read address pointer to zero.

WE (write enable) is used to enable or disable incrementing of the internal write address pointer.

IE (input enable) is used to enable writing data from the field memory input pins into the memory core, or to disable writing and thereby preserving the previous content of the memory (write mask function).

RE (read enable) is used to enable or disable incrementing the internal read address pointer.

OE (output enable) is used to enable or disable data output to the output pins.

3. Serial Interface

3.1. I²C-Bus Interface

Communication between the VPC and the external controller is done via I²C-bus. The VPC has an I²C-bus slave interface and uses I²C clock synchronization to slow down the interface if required. The I²C-bus interface uses one level of subaddress: one I²C-bus address is used to address the IC and a subaddress selects one of the internal registers. For multi VPC32xxD applications the following three I²C-bus chip addresses are selectable via I2CSEL pin:

A6	A5	A4	A3	A2	A1	A0	R/W	I2CSEL
1	0	0	0	1	1	1	1/0	V _{SUP}
1	0	0	0	1	1	0	1/0	VRT
1	0	0	0	1	0	0	1/0	GND

The registers of the VPC have 8 or 16-bit data size; 16-bit registers are accessed by reading/writing two 8-bit data words.

Figure 3–1 shows I²C-bus protocols for read and write operations of the interface; the read operation requires an extra start condition and repetition of the chip address with read command set.

3.2. Control and Status Registers

Table 3–1 gives definitions of the VPC control and status registers. The number of bits indicated for each register in the table is the number of bits implemented in hardware, i.e. a 9-bit register must always be accessed using two data bytes but the 7 MSB will be 'don't care' on write operations and '0' on read operations. Write registers that can be read back are indicated in Table 3–1.

Functions implemented by software in the on-chip control microprocessor (FP) are explained in Table 3–1.

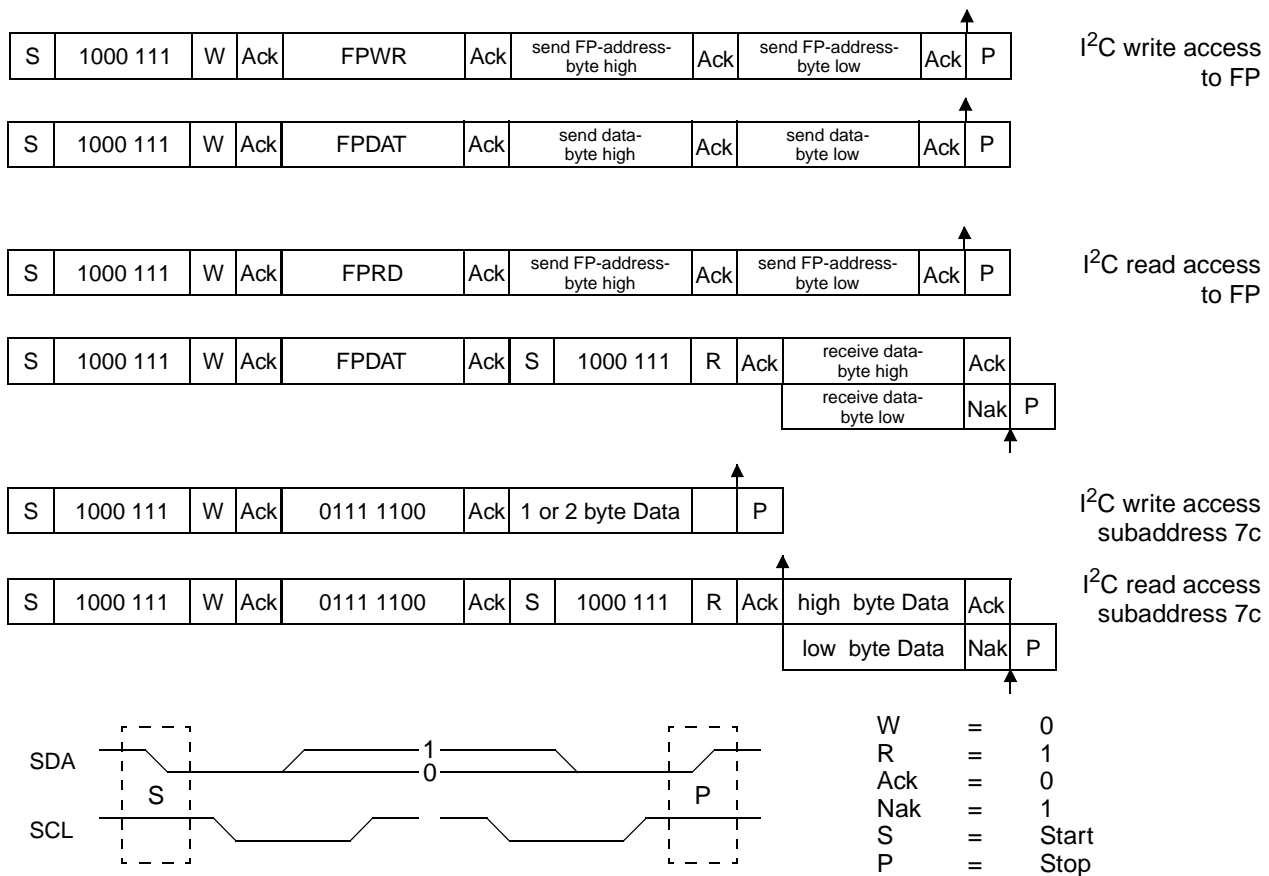

Fig. 3–1: I²C-bus protocols

A hardware reset initializes all control registers to 0. The automatic chip initialization loads a selected set of registers with the default values given in Table 3–1.

The register modes given in Table 3–1 are

- w: write only register
- w/r: write/read data register
- r: read data from VPC
- v: register is latched with vertical sync

The mnemonics used in the Intermetall VPC demo software are given in the last column.

Table 3–1: Control and status registers

I ² C Sub-address	Number of bits	Mode	Function	Default	Name
FP Interface					
h'35	8	r	FP status bit [0] write request bit [1] read request bit [2] busy	–	FPSTA
h'36	16	w	bit[8:0] 9-bit FP read address bit[11:9] reserved, set to zero	–	FPRD
h'37	16	w	bit[8:0] 9-bit FP write address bit[11:9] reserved, set to zero	–	FPWR
h'38	16	w/r	bit[11:0] FP data register, reading/writing to this register will autoincrement the FP read/write address. Only 16 bit of data are transferred per I ² C telegram.	–	FPDAT
Black Line Detector					
h'12	16	w/r	read only register, do not write to this register! After reading, LOWLIN and UPLIN are reset to 127 to start a new measurement. bit[6:0] number of lower black lines bit[7] always 0 bit[14:8] number of upper black lines bit[15] 0/1 normal/black picture	–	BLKLIN LOWLIN UPLIN BLKPIC
Pin Circuits					
h'1F	16	w/r	SYNC PIN CONTROL: bit[2:0] 0..7 reserved (set to 0) bit[3] 0/1 pushpull/tristate for AVO Pin bit[4] 0/1 pushpull/tristate for other video SYNC Pins bit[5] 0 reserved (set to zero) CLOCK/FIFO PIN CONTROL: bit[6] 0/1 pushpull/tristate for LLC1 bit[7] 0/1 pushpull/tristate for LLC2 bit[8] 0 reserved (set to 0) bit[9] 0/1 pushpull/tristate for FIFO control pins LUMA/CHROMA DATA PIN (LB[7:0], CB[7:0]) CONTROL: bit[10] 0/1 tristate /pushpull for Chroma Data pins bit[11] 0/1 tristate /pushpull for Luma Data pins bit[15:12] reserved (set to 0)	0 0 0 0 0 0 0 0 0 0 0	TRPAD AVODIS SNCDIS LLC1DIS LLC2DIS FFSNCDIS CDIS YDIS
h'20	8	w/r	SYNC GENERATOR CONTROL: bit[1:0] 00 AVO and active Y/C data at same time 01 AVO precedes Y/C data one clock cycle 10 AVO precedes Y/C data two clock cycles 11 AVO precedes Y/C data three clock cycles bit[2] 0/1 positive/negative polarity for HS signal bit[3] 0/1 positive/negative polarity for HC signal bit[4] 0/1 positive/negative polarity for AVO signal bit[5] 0/1 positive/negative polarity for VS signal bit[6] 0/1 positive/negative polarity for HELP signal bit[7] 0/1 positive/negative polarity for INTLC signal	0 0 0 0 0 0 0	SYNCMODE AVOPRE HSINV HCINV AVOINV VSINV HELPINV INTLCINV

I ² C Sub-address	Number of bits	Mode	Function	Default	Name
h'23	16	w/r	OUTPUT STRENGTH: bit[3:0] 0..15 output pin strength (0 = strong, 15 = weak)	0	OUTSTR PADSTR
			bit[9:4] 32 address of output pin FIFO control pins FFIE, FFOE, FFWR, FFRE and FFRSTWR	0	PADADD
			bit[10] 0/1 read/write output strength	0	PADWR
			bit[15:11] reserved (set to 0)	0	
h'30	8	w/r	V-SYNC DELAY CONTROL: bit[7:0] VS delay (8 LLC clock cycles per LSB)	0	VSDDEL VSDDEL
656 Interface					
h'24	8	w/r	656 OUTPUT INTERFACE		
			bit [0] 1 disable hor. & vert. blanking of invalid data in 656 mode	0	OUT656 DBLNK
			bit [1] 0 use vertical window as VFLAG	0	VSMODE
			bit [2] 1 use vsync as VFLAG	0	HSUP
			bit [3] enable suppression of 656-headers during invalid video lines	0	656enable
			bit [4] 0/1 LLC1/LLC2 used as reference clock	0	DBLCLK
bit [5] 0/1 output mode: DIGIT 3000 / LLC	1	OMODE			
Sync Generator					
h'21	16	w/r	LINE LENGTH: bit[10:0] LINE LENGTH register In LLC mode, this register defines the cycle of the sync counter which generates the SYNC pulses. In LLC mode, the synccounter counts from 0 to LINE LENGTH, so this register has to be set to "number of pixels per line -1". In DIGIT3000 mode, LINE LENGTH has to be set to 1295 for correct adjustment of vertical signals. bit[15:11] reserved (set to 0)	1295	LINLEN
h'26	16	w/r	HC START: bit[10:0] HC START defines the beginning of the HC signal in respect to the value of the sync counter. bit[15:11] reserved (set to 0)	50	HCSTRT
h'27	16	w/r	bit[10:0] HC STOP defines the end of the HC signal in respect to the value of the sync counter. bit[15:11] reserved (set to 0)	800	HCSTOP

I ² C Sub-address	Number of bits	Mode	Function	Default	Name
h'28	16	w/r	<p>AVO START: bit[10:0] AVO START defines the beginning of the AVO signal in respect to the value of the sync counter.</p> <p>bit[11] reserved (set to 0)</p> <p>bit[12] 0/1 dis/enable suppression of AVO during VBI and invalid video lines</p> <p>bit[13] 0/1 vertical standard for flywheel (312/262 lines) used if FLW is set</p> <p>bit[14] 0/1 disable interlace for flywheel</p> <p>bit[15] 0/1 enable vertical free run mode (flywheel)</p>	60 0 0 0 0	AVSTRT AVOGATE FLWSTD DIS_INTL FLW
h'29	16	w/r	<p>AVO STOP: bit[10:0] AVO STOP defines the end of the AVO signal in respect to the value of the sync counter.</p> <p>bit[15:11] reserved for test picture generation (set to 0 in normal operation)</p> <p>bit[11] 0/1 disable/enable test pattern generator</p> <p>bit[13:12] luma output mode: 00 Y = ramp (240 ... 17) 01 Y = 16 10 Y = 90 11 Y = 240</p> <p>bit[14] 0/1 chroma output: 422/411 mode</p> <p>bit[15] 0/1 chroma output: pseudo color bar/zero if LMODE = 0</p>	0 0 0 0 0	AVSTOP COLBAREN LMODE M411 CMODE
h'22	16	w/r	<p>NEWLINE: bit[10:0] NEWLINE defines the readout start of the next line in respect to the value of the sync counter. The value of this register must be greater than 31 for correct operation and should be identical to AVOSTART (recommended). In case of 1H-bypass mode for scaler block, NEWLINE has no function.</p> <p>bit[15:11] reserved (set to 0)</p>	50	NEWLIN

I ² C Sub-address	Number of bits	Mode	Function	Default	Name
PIP Control					
h'84	16	w/r	<p>VPC MODE:</p> <p>bit[0] 0/1 dis-/enable field memory control for PIP</p> <p>bit[1] 0/1 double/single VPC application</p> <p>bit[2] 0/1 select VPC_{pip}/VPC_{main} mode</p> <p>bit[3] 0/1 4:3/16:9 screen</p> <p>bit[4] 0/1 13.5/16 MHz output pixel rate</p> <p>bit[5] 0/1 vertical PIP window size is based on a 625/525 line video</p> <p>bit[7:6]</p> <p>00 TI TMS4C2972/3</p> <p>01 PHILIPS SAA 4955TJ</p> <p>10 reserved</p> <p>11 other (OKI MSM5412222, ...)</p> <p><i>bit[11:8] are evaluated, only if bit[7:6]=11</i></p> <p>bit[8] 0/1 delay the video output for 0/1 LLC1 clock</p> <p>bit[9] 0/1 pos/neg polarity for WE and RE signals</p> <p>bit[10] 0/1 pos/neg polarity for IE and OE signals</p> <p>bit[11] 0/1 pos/neg polarity for RSTWR signal</p> <p>bit[15:12] reserved (set to 0)</p> <p>This register is updated when the PIOPER register is written.</p>	0	<p>VPCMODE</p> <p>ENA_PIP</p> <p>SINGVPC</p> <p>MAINVPC</p> <p>F16TO9</p> <p>F16MHZ</p> <p>W525</p> <p>FIFOTYPE</p> <p>VIDEODEL</p> <p>WEREINV</p> <p>IEOEINV</p> <p>RSTWRINV</p>
h'85	16	w/r	<p>PIP MODE:</p> <p>bit[3:0] the number of the PIP mode to be selected</p> <p>bit[4] 0/1 write one/both input field(s) of a frame into the field buffer in case TWOFB=0, only used in the expert mode, for VPC_{pip} or VPC_{single}</p> <p>bit[5] 0/1 use one/two field buffer(s), only used in the expert mode</p> <p><i>bit[13:6] are used, only for VPC_{main}</i></p> <p>bit[6] 0/1 show video/the background color in the main picture, only used in the expert mode</p> <p>bit[7] 0/1 dis-/enable the vertical up-shifting of the main picture</p> <p>bit[13:8] 0/1 number of lines for vertical up-shift</p> <p>bit[15:14] reserved (set to 0)</p> <p>This register is updated when the PIOPER register is written.</p>	0	<p>PIPMODE</p> <p>MODSEL</p> <p>FRAMOD</p> <p>TWOFB</p> <p>SHOWBGD</p> <p>VSHIFT</p> <p>VOFFSET</p>

I ² C Sub-address	Number of bits	Mode	Function	Default	Name
h'83	8	w/r	<p>PIP OPERATION:</p> <p><i>For VPC_{pip} or VPC_{single}:</i></p> <p>bit[1:0] the number of the inset picture to be accessed in the x-direction</p> <p>bit[3:2] the number of the inset picture to be accessed in the y-direction</p> <p>bit[6:4] 000 start to write the inset picture with a frame</p> <p>001 stop writing</p> <p>010 fill the frame with the color COLFR1</p> <p>011 fill the frame with the color COLFR2</p> <p>100 fill the inset picture with a frame using the color COLBGD</p> <p>101 fill the inset picture w/o a frame using the color COLBGD</p> <p>110 start to write the inset picture w/o a frame</p> <p>111 write the main picture (only for VPC_{single})</p> <p><i>For VPC_{main}:</i></p> <p>bit[3:0] reserved set to 0</p> <p>bit[6:4] 000 start to display PIP</p> <p>001 stop to display PIP</p> <p>rest reserved set to 0</p> <p>bit[7] 0/1 processed/new command flag, normally write 1. After the new PIP setting takes effect, this bit is set to 0 to indicate operation complete.</p>	0	PIOPER NSPX NSPY WRPIC WRSTOP WRFCOL1 WRFCOL2 WRBGD WRBGDNF WRPICNF WRMAIN DISSTARD DISSTOP NEWCMD
h'80	16	w/r	<p>BACKGROUND COLOR:</p> <p>bit[[4:0] bit b₇ to b₃ of the chrominanc component C_R</p> <p>bit[9:5] bit b₇ to b₃ of the chrominanc component C_B</p> <p>bit[15:10] bit b₇ to b₂ of the luminance component Y (all other bits of YC_BC_R are set to 0)</p> <p>This register is updated when the PIOPER register is written.</p>	0	COLBGD
h'81	16	w/r	<p>FRAME COLOR 1:</p> <p><i>Only used for PC_{pip} or VPC_{single}:</i></p> <p>bit[[4:0] bit b₇ to b₃ of the chrominanc component C_R</p> <p>bit[9:5] bit b₇ to b₃ of the chrominanc component C_B</p> <p>bit[15:10] bit b₇ to b₂ of the luminance component Y (all other bits of YC_BC_R are set to 0)</p> <p>This register is updated when the PIOPER register is written.</p>	h'3e0	COLFR1
h'82	16	w/r	<p>FRAME COLOR 2:</p> <p><i>only used for VPC_{pip} or VPC_{single}:</i></p> <p>bit[[4:0] bit b₇ to b₃ of the chrominanc component C_R</p> <p>bit[9:5] bit b₇ to b₃ of the chrominanc component C_B</p> <p>bit[15:10] bit b₇ to b₂ of the luminance component Y (all other bits of YC_BC_R are set to 0)</p> <p>This register is updated when the PIOPER register is written.</p>	h'501f	COLFR2

I ² C Sub-address	Number of bits	Mode	Function	Default	Name
h'86	16	w/r	<p>LINE OFFSET: <i>Only used for VPC_{pip} or for the expert mode of VPC_{single}:</i> bit[8:0] line offset of the upper-left corner of the inset picture with NSPX=0 and NSPY=0 in the display window</p> <p>bit[9] 0/1 use the internal default/external setting via bit[8:0]</p> <p>bit[15:10] reserved (set to 0)</p> <p>This register is updated when the PIOPER register is written.</p>	0	LINOFFS
h'89	16	w/r	<p>PIXEL OFFSET: <i>Only used for VPC_{pip} or for the expert mode of VPC_{single}:</i> bit[7:0] quarter of the pixel offset of the upper-left corner of the inset picture with NSPX=0 and NSPY=0 in the display window</p> <p>bit[8] 0/1 use the internal default/external setting via bit[7:0]</p> <p>bit[15:9] reserved (set to 0)</p> <p>This register is updated when the PIOPER register is written.</p>	0	PIXOFFS
h'87	16	w/r	<p>VERTICAL START: bit[8:0] <i>For VPC_{pip} and VPC_{single}:</i> vertical start of the active video segment to be used as a inset picture <i>For the VPC_{main}:</i> vertical start of the inset picture(s) in the main picture</p> <p>bit[9] 0/1 use the internal default/external setting via bit[8:0]</p> <p>bit[15:10] reserved (set to 0)</p>	0	VSTR
h'8a	16	w/r	<p>HORIZONTAL START: bit[7:0] <i>For VPC_{pip} and VPC_{single}:</i> horizontal start of the active video segment to be used as a inset picture <i>For VPC_{main}:</i> horizontal start of the inset picture(s) in the main picture In both cases HSTR is given by the number of 4-pixel-groups.</p> <p>bit[8] 0/1 use the internal default/external setting via bit[7:0]</p> <p>bit[15:9] reserved (set to 0)</p>	0	HSTR
h'88	16	w/r	<p>NUMBER OF LINES: <i>Only used in the expert modes:</i> bit[8:0] <i>For VPC_{pip} and VPC_{single}:</i> number of lines of the active video segment to be used as a inset picture <i>For VPC_{main}:</i> number of lines of the inset picture(s)</p> <p>bit[15:9] reserved (set to 0)</p> <p>This register is updated when the PIOPER register is written.</p>	0	NLIN

I ² C Sub-address	Number of bits	Mode	Function	Default	Name
h'8b	8	w/r	NUMBER OF PIXEL PER LINE: <i>Only used in the expert modes:</i> bit[7:0] <i>For VPC_{pip} and VPC_{single}:</i> quarter of the number of pixels per line in the active video segment to be used as a inset picture <i>For VPC_{main}:</i> quarter of the number of pixels per line of the inset picture(s) This register is updated when the PIOPER register is written.	0	NPIX
h'8c	16	w/r	NUMBER OF PIXEL PER LINE IN THE FIELD BUFFER(S): bit[7:0] quarter of the number of allocated pixels per line in the field buffer(s) bit[8] 0/1 use the internal default/external setting via bit[7:0] (must be set in the expert mode, optional in the predefined modes) bit[15:9] reserved (set to 0) This register is updated when the PIOPER register is written.	0	NPFB
h'8d- h'8f			reserved, don't write		
CIP Control					
h'90	16	w/r	SATURATION OF THE RGB/YC _r C _b COMPONENT INPUT: bit[5:0] saturation Cb (0..63) bit[11:6] saturation Cr (0..63) bit[15:12] reserved (set to 0)	18 23	CIPSAT SATCb SATCr
h'91	8	w/r	TINT CONTROL OF THE RGB/YUV COMPONENT INPUT: bit[5:0] tint (-20..+20 in degrees) bit[7:6] reserved (set to 0)	0	CIPTNT
h'92	16	w/r	BRIGHTNESS OF THE RGB/YUV COMPONENT INPUT: bit[7:0] brightness (-128..+127) CONTRAST OF THE RGB/YUV COMPONENT INPUT: bit[13:8] contrast (0..63) bit[15:14] reserved (set to 0)	68 28	CIPBRCT CIPBR CIPCT
h'94	8	w/r	SOFTMIXER CONTROL: bit[0] 0/1 rgb/main video delay (0:normal 1:dynamic) bit[1] 0/1 linear (0)/nonlinear(1) mixer select bit[7:4] fastblank gain (-7 .. +7) bit[3:2] reserved (set to 0)	0 0 -1	CIPMIX1 RGBDLY SELLIN FBGAIN
h'95	8	w/r	SOFTMIXER CONTROL: bit[5:0] fastblank offset correction (0..63) (fb -> fb-FBOFFS) bit[7:6] fastblank mode: x0 force rgb to cip out (equ. fb=0) 01 normal mode (fb active) 11 force main yuv to cip out (equ. fb=64)	32 11	CIPMIX2 FBOFFS FBMODE

I ² C Sub-address	Number of bits	Mode	Function	Default	Name
h'96	8	w/r	ADC RANGE : bit[0] reserved (set to 0) bit[1] 0/1 0/+3dB extended ADC range INPUT PORT SELECT : bit[2] 0/1 1/2 input port select SOFTMIXER CONTROL: bit[5] 0/1 clamp fb to a programable value (0:normal 1: fb=31-FBOFFS) bit[6] 0/1 bypass chroma 444→422 decimation filter RGB/YUV SELECT: bit[7] 0/1 rgb/yuv input select bit[4:3] reserved (set to 0)	0 0 0 1 0	CIPCNTL XAR RGBSEL FBCLP CIPCIFY YUV
h'97	8	r	FB MONITOR: bit[0] 0/1 set by fb high, reset by reg. read and fb low bit[1] 0/1 set by fb falling edge, reset by reg. read bit[2] 0/1 set by fb rising edge, reset by reg. read bit[3] 0/1 fb status at register read CLIP DETECTOR: bit[4] 0/1 rgb/yuv input clip detect, reset by read	– – – – –	CIPMON FBHIGH FBFALL FBRISE FBSTAT CLIPD
Hardware ID					
h'9f	16	r	Hardware version number bit[7:0] 0/255 hardware id 1=A, 2=B aso. bit[11:8] 0/3 product code 0 VPC32x0D 1 VPC32x1D 2 VPC32x2D 3 VPC32x3D bit[15:12] 0/15 product code 3 VPC323xD 100Hz version 4 VPC324xD 50Hz version	read only	

FP Sub-address	Function	Default	Name
h'2f	VGA mode select, pull-in range is limited to 2% bit[1:0] 0 31.5 kHz 1 35.2 kHz 2/3 37.9 kHz is set to 0 by FP if VGA = 0 bit[10] 0/1 disable/enable VGA mode bit[11] status bit, write 0, this bit is set to 1 to indicate operation complete.	0 0	VGA_C VGAMODE VGA
Comb Filter			
h'28	comb filter control register bit[1:0] notch filter select 00 flat frequency characteristic 01 min. peaked 10 med. peaked 11 max. peaked bit[3:2] diagonal dot reduction 00 min. reduction ... 11 max. reduction bit[4:5] horizontal difference gain 00 min. gain ... 11 max. gain bit[7:6] vertical difference gain 00 max. gain ... 11 min. gain bit[11:8] vertical peaking gain 0 no vertical peaking... 15 max. vertical peaking	h'e7 3 1 2 3 0	COMB_UC NOSEL DDR HDG VDG VPK
h'55	comb filter test register bit[1:0] reserved, set ot 0 bit[2] 0/1 disable/enable vertical peaking DC rejection filter bit[3] 0/1 disable/enable vertical peaking coring bit[11:4] reserved, set to 0	0 0	CMB_TST DCR COR
Color Processing			
h'30	Saturation control bit[11:0] 0..4095 (2070 corresponds to 100% saturation)	2070	ACC_SAT
h'17a	ACC PAL+ Helper gain adjust, gain is referenced to PAL burst, allowed values from 256..1023 a value of zero allows manual adjust of Helper amplitude via ACCh	787	HLPGAIN
h'17d	ACC multiplier value for PAL+ Helper Signal b[10:0] eeemmmmmmm m * 2 ^{-e}	1280	ACCH
h'39	amplitude killer level (0:killer disabled)	25	KILVL
h'3a	amplitude killer hysteresis	5	KILHY
h'16c	automatic helper disable for nonstandard signals bit[11:0] 0 automatic function disabled bit[1:0] 01 enable bit[11:2] 1..50 number of fields to switch on helper signal	0	HLPDIS
h'dc	NTSC tint angle, $\pm 512 = \pm \pi/4$	0	TINT

FP Sub-address	Function	Default	Name
DVCO			
h'f8	crystal oscillator center frequency adjust, -2048 ... 2047	-720	DVCO
h'f9	crystal oscillator center frequency adjustment value for line-lock mode, true adjust value is DVCO – ADJUST. For factory crystal alignment, using standard video signal: disable autolock mode, set DVCO = 0, set lock mode, read crystal offset from ADJUST register and use negative value for initial center frequency adjustment via DVCO.	read only	ADJUST
h'f7	crystal oscillator line-locked mode, lock command/status write: 100 enable lock 0 disable lock read: 0 unlocked >2047 locked	0	XLCK
h'b5	crystal oscillator line-locked mode, autolock feature. If autolock is enabled, crystal oscillator locking is started automatically. bit[11:0] threshold, 0:autolock off	400	AUTOLCK
FP Status Register			
h'12	general purpose control bits bit[2:0] reserved, do not change bit[3] vertical standard force bit[8:4] reserved, do not change bit[9] disable flywheel interlace bit[11:10] reserved, do not change to enable vertical free run mode set vfrc to 1 and dflw to 0	0 1	VFRC DFLW
h'13	standard recognition status bit[0] 1 vertical lock bit[1] 1 horizontally locked bit[2] 1 no signal detected bit[3] 1 color amplitude killer active bit[4] 1 disable amplitude killer bit[5] 1 color ident killer active bit[6] 1 disable ident killer bit[7] 1 interlace detected bit[8] 1 no vertical sync detection bit[9] 1 spurious vertical sync detection bit[12:10] reserved	-	ASR
h'14	input noise level, available only for VPC 323xC	read only	NOISE
h'cb	number of lines per field, P/S: 312, N: 262	read only	NLPF
h'15	vertical field counter, incremented per field	read only	VCNT
h'74	measured sync amplitude value, nominal: 768 (PAL), 732 (NTSC)	read only	SAMPL
h'31	measured burst amplitude	read only	BAMPL
h'f0	firmware version number bit[7:0] internal revision number bit[11:8] firmware release hardware id see I ² C register h'9f	read only	-

FP Sub-address	Function	Default	Name
Scaler Control Register			
h'40	<p>scaler mode register</p> <p>bit[1:0] scaler mode</p> <p>0 linear scaling mode</p> <p>1 nonlinear scaling mode, 'panorama'</p> <p>2 nonlinear scaling mode, 'waterglass'</p> <p>3 reserved</p> <p>bit[2] reserved, set to 0</p> <p>bit[3] color mode select</p> <p>0/1 4:2:2 mode / 4:1:1 mode</p> <p>bit[4] scaler bypass</p> <p>bit[5] reserved, set to 0</p> <p>bit[6] luma output format</p> <p>0 ITU-R luma output format (16–240)</p> <p>1 CVBS output format</p> <p>bit[7] chroma output format</p> <p>0/1 ITU-R (offset binary) / signed</p> <p>bit[10:8] reserved, set to 0</p> <p>bit[11] 0 scaler update command, when the registers are updated the bit is set to 1</p>	0	<p>SCMODE</p> <p>PANO</p> <p>S411</p> <p>BYE</p> <p>YOF</p> <p>COF</p>
h'41	<p>pip control register</p> <p>bit[1:0] horizontal downsampling</p> <p>0 no downsampling</p> <p>1 downsampling by 2</p> <p>2 downsampling by 4</p> <p>3 downsampling by 8</p> <p>bit[3:2] vertical compression for PIP</p> <p>0 compression by 2</p> <p>1 compression by 3</p> <p>2 compression by 4</p> <p>3 compression by 6</p> <p>bit[4] vertical filter enable</p> <p>bit[5] interlace offset for vertical filter (NTSC mode only)</p> <p>0 start in line 283 of 2nd field (ITUR 656 spec)</p> <p>1 start in line 282 of 2nd field (NTSC spec)</p> <p>this register is updated when the scaler mode register is written</p>	0	<p>SCPIP</p> <p> DownsAMP</p> <p>PIPSIZE</p> <p>PIPE</p> <p>INTERLACE_OFF</p>
h'42	<p>active video length for 1H-FIFO</p> <p>bit[11:0] length in pixels</p> <p>D3000 mode (1296/h)1080</p> <p>LLC mode (864/h)720</p> <p>this register is updated when the scaler mode register is written</p>	1080	FFLIM
h'43	<p>scaler1 coefficient: This scaler compresses the signal.</p> <p>For compression by a factor c, the value $c*1024$ is required.</p> <p>bit[11:0] allowed values from 1024... 4095</p> <p>This register is updated when the scaler mode register is written.</p>	1024	SCINC1
h'44	<p>scaler2 coefficient: This scaler expands the signal.</p> <p>For expansion by a factor c, the value $1/c*1024$ is required.</p> <p>bit[11:0] allowed values from 256..1024</p> <p>This register is updated when the scaler mode register is written.</p>	1024	SCINC2
h'45	<p>scaler1/2 nonlinear scaling coefficient</p> <p>This register is updated when the scaler mode register is written.</p>	0	SCINC

FP Sub-address	Function	Default	Name
h'47 – h'4b	scaler1 window controls, see table 5 12-bit registers for control of the nonlinear scaling This register is updated when the scaler mode register is written.	0	SCW1_0 – 4
h'4c – h'50	scaler2 window controls, see table 5 12-bit registers for control of the nonlinear scaling This register is updated when the scaler mode register is written.	0	SCW2_0 – 4
h'52	brightness register bit[7:0] luma brightness –128...127 ITU-R output format: 16 CVBS output format: –4 bit[9:8] horizontal lowpass filter for Y/C 0 bypass 1 filter 1 2 filter 2 3 filter 3 bit[10] horizontal lowpass filter for highresolution chroma 0/1 bypass/filter enabled this register is updated when the scaler mode register is written	16 16 0 0	SCBRI BR LPF2 CBW2
h'53	contrast register bit[5:0] luma contrast 0..63 ITU-R output format: 48 bit[7:6] horizontal peaking filter 0 broad 1 med 2 narrow bit[10:8] peaking gain 0 no peaking... 7 max. peaking bit[10] peaking filter coring enable 0/1 bypass/coring enable this register is updated when the scaler mode register is written	48 48 0 0 0 0	SCCT CT PFS PK PKCOR
LLC Control Register			
h'65	vertical freeze start freeze llc pll for llc_start < line number < llc_stop bit[11:0] allowed values from –156...+156	–10	LLC_START
h'66	vertical freeze stop freeze llc pll for llc_start < line number < llc_stop bit[11:0] allowed values from –156...+156	4	LLC_STOP
h'69 h'6a	20 bit llc clock center frequency 12.27 MHz –79437 = h'FEC9B2 13.5 MHz 174763 = h'02AAAB 14.75 MHz 194181 = h'02F685 16 MHz –135927 = h'FDED08 18 MHz 174763 = h'02AAAB	42 = h'02A 2731 = h'AAB	LLC_CLOCKH LLC_CLOCKL

FP Sub-address	Function	Default	Name
h'61	pll frequency limiter, 8% 12.27 MHz 30 13.5 MHz 54 14.75 MHz 62 16 MHz 48 18 MHz 54	54	LLC_DFLIMIT
h'6d	llc clock generator control word bit[5:0] hardware register shadow llc_clkc = 5→12.27 MHz llc_clkc = 5→13.5 MHz llc_clkc = 35→14.75 MHz llc_clkc = 3→16 MHz llc_clkc = 3→18 MHz bit[10:6] reserved bit[11] 0/1 enable/disable llc pll	2053	LLC_CLKC

Table 3–3: Control Registers of the Fast Processor that are used for the control of DDP 3300A

- this function is only available in the 50 Hz version (VPC 324xD)
- default values are initialized at reset
- * indicates: register is initialized according to the current standard when SDT register is changed

FP Sub-address	Function	Default	Name
FP Display Control Register			
h'130	White Drive Red (0...1023)	700	WDR ¹⁾
h'131	White Drive Green (0...1023)	700	WDG ¹⁾
h'132	White Drive Blue (0...1023)	700	WDB ¹⁾
h'139	Internal Brightness, Picture (0 ..511), the center value is 256, the range allows for both increase and reduction of brightness.	256	IBR
h'13c	Internal Brightness, measurement (0...511), the center value is 256, the brightness for measurement can be set to measure at higher cutoff current. The measurement brightness is independent of the drive values.	256	IBRM
h'13a	Analog Brightness for external RGB (0...511), the center value is 256, the range allows for both increase and reduction of brightness.	256	ABR
h'13b	Analog Contrast for external RGB (0...511)	350	ACT
¹⁾ The white drive values will become active only after writing the blue value WDB, latching of new values is indicated by setting the MSB of WDB.			
FP Display Control Register, BCL			
h'144	BCL threshold current, 0...2047 (max ADC output ~1152)	1000	BCLTHR
h'142	BCL time constant 0...15 →13 ... 1700 msec	15	BCLTM
h'143	BCL loop gain. 0..15	0	BCLG
h'145	BCL minimum contrast 0 ...1023	307	BCLMIN
h'105	Test register for BCL/EHT comp. function, register value: 0 normal operation 1 stop ADC offset compensation x>1 use x in place of input from Measurement ADC	0	BCLTST
FP Display Control Register, Deflection			
h'103	interlace offset, –2048 ...2047 This value is added to the SAWTOOTH output during one field.	0	INTLC
h'102	discharge sample count for deflection retrace, SAWTOOTH DAC output impedance is reduced for DSCC lines after vertical retrace.	7	DSCC
h'11f	vertical discharge value, SAWTOOTH output value during discharge operation, typically same as A0 init value for sawtooth.	–1365	DSCV
h'10b	EHT (electronic high tension) compensation coefficient, 0...511	0	EHT
h'10a	EHT time constant. 0 ..15 → 3.2 ...410 msec	15	EHTTM

Control registers, continued

FP Sub-address	Function	Default	Name
FP Display Control Register, Vertical Sawtooth			
h'110	DC offset of SAWTOOTH output This offset is independent of EHT compensation.	0	OFS
h'11b	accu0 init value	-1365	A0
h'11c	accu1 init value	900	A1
h'11d	accu2 init value	0	A2
h'11e	accu3 init value	0	A3
FP Display Control Register, East-West Parabola			
h'12b	accu0 init value	-1121	A0
h'12c	accu1 init value	219	A1
h'12d	accu2 init value	479	A2
h'12e	accu3 init value	-1416	A3
h'12f	accu4 init value	1052	A4

3.2.1. Calculation of Vertical and East-West Deflection Coefficients

In Table 3–4 the formula for the calculation of the deflection initialization parameters from the polynomial coefficients a,b,c,d,e is given for the vertical and East-West deflection. Let the polynomial be

$$P \div a + b(x - 0.5) + c(x - 0.5)^2 + d(x - 0.5)^3 + e(x - 0.5)^4$$

The initialization values for the accumulators a0..a3 for vertical deflection and a0..a4 for East-West deflection are 12-bit values. The coefficients that should be used to calculate the initialization values for different field frequencies are given below, the values must be scaled by 128, i.e. the value for a0 of the 50 Hz vertical deflection is

$$a0 = (a \cdot 128 - b \cdot 1365.3 + c \cdot 682.7 - d \cdot 682.7) \div 128$$

3.2.2. Scaler Adjustment

In case of linear scaling, most of the scaler registers need not be set. Only the scaler mode, active video length, and the fixed scaler increments (scinc1/scinc2) must be written.

The adjustment of the scaler for nonlinear scaling modes should use the parameters given in table 3–5. An example for 'panorama vision' mode with 13.5 MHz line-locked clock is depicted in Fig. 3–2. The figure shows the scaling of the input signal and the variation of the scaling factor during the active video line. The scaling factor starts below 1, i.e. for the borders the video data is expanded by scaler 2. The scaling factor becomes one and compression scaling is done by scaler 1. When the picture center is reached, the scaling factor is held constant. At the second border the scaler increment is inverted and the scaling factor changes back symmetrically. The picture indicates the function of the scaler increments and the scaler window parameters. The correct adjustment requires that pixel counts for the respective windows are always in number of output samples of scaler 1 or 2.

Table 3–4: Tables for the Calculation of Initialization values for Vertical Sawtooth and East-West Parabola

Vertical Deflection 50 Hz				
	a	b	c	d
a0	128	-1365.3	+682.7	-682.7
a1		899.6	-904.3	+1363.4
a2			296.4	-898.4
a3				585.9
Vertical Deflection 60 Hz				
	a	b	c	d
a0	128	-1365.3	+682.7	-682.7
a1		1083.5	-1090.2	+1645.5
a2			429.9	-1305.8
a3				1023.5

East-West Deflection 50 Hz					
	a	b	c	d	e
a0	128	-341.3	1365.3	-85.3	341.3
a1		111.9	-899.6	84.8	-454.5
a2			586.8	-111.1	898.3
a3				72.1	-1171.7
a4					756.5
East-West Deflection 60 Hz					
	a	b	c	d	e
a0	128	-341.3	1365.3	-85.3	341.3
a1		134.6	-1083.5	102.2	-548.4
a2			849.3	-161.2	1305.5
a3				125.6	-2046.6
a4					1584.8

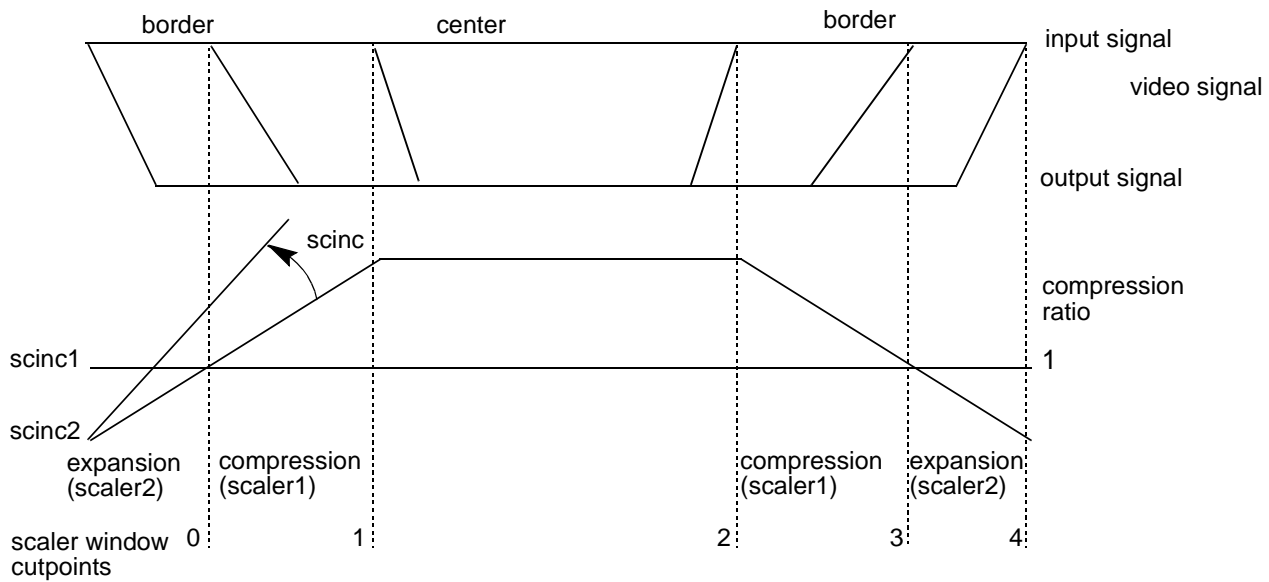

Fig. 3–2: Scaler operation for ‘panorama’ mode at 13.5 MHz

Table 3–5: Set-up values for nonlinear scaler modes

Mode	DIGIT3000 (20.25 MHz)				LLC (13.5 MHz)			
	‘waterglass’ border 35%		‘panorama’ border 30%		‘waterglass’ border 35%		‘panorama’ border 30%	
Register	center 3/4	center 5/6	center 4/3	center 6/5	center 3/4	center 5/6	center 4/3	center 6/5
scinc1	1643	1427	1024	1024	2464	2125	1024	1024
scinc2	1024	1024	376	611	1024	1024	573	914
scinc	90	56	85	56	202	124	190	126
fflim	945	985	921	983	719	719	681	715
scw1 – 0	110	115	83	94	104	111	29	13
scw1 – 1	156	166	147	153	104	111	115	117
scw1 – 2	317	327	314	339	256	249	226	241
scw1 – 3	363	378	378	398	256	249	312	345
scw1 – 4	473	493	461	492	360	360	341	358
scw2 – 0	110	115	122	118	104	111	38	14
scw2 – 1	156	166	186	177	104	111	124	118
scw2 – 2	384	374	354	363	256	249	236	242
scw2 – 3	430	425	418	422	256	249	322	346
scw2 – 4	540	540	540	540	360	360	360	360

4. Specifications

4.1. Outline Dimensions

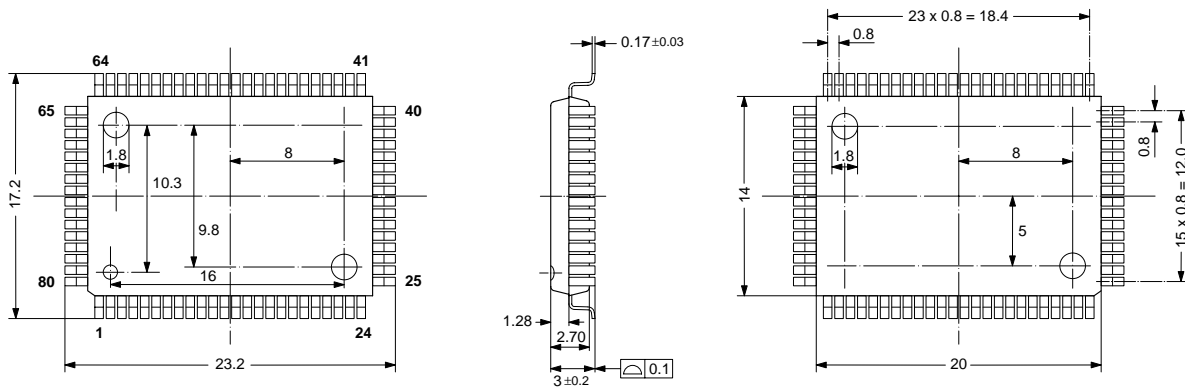

SPGS0025-1/1E

Fig. 4–1: 80-Pin Plastic Quad Flat Package (PQFP80)

Weight approximately 1.61 g
 Dimensions in mm

4.2. Pin Connections and Short Descriptions

NC = not connected

LV = if not used, leave vacant

X = obligatory; connect as described in circuit diagram

SUPPLYA=4.75...5.25V, SUPPLYD=3.15...3.45V

Pin No. PQFP 80-pin	Pin Name	Type	Connection (if not used)	Short Description
1	B1/CB1IN	IN	VREF	Blue1/Cb1 Analog Component Input
2	G1/Y1IN	IN	VREF	Green1/Y1 Analog Component Input
3	R1/CR1IN	IN	VREF	Red1/Cr1 Analog Component Input
4	B2/CB2IN	IN	VREF	Blue2/Cb2 Analog Component Input
5	G2/Y2IN	IN	VREF	Green2/Y2 Analog Component Input
6	R2/CR2IN	IN	VREF	Red2/Cr2 Analog Component Input
7	ASGF		X	Analog Shield GND _F
9	V _{SUPCAP}	SUPPLYD	X	Supply Voltage, Digital Decoupling Circuitry
10	V _{SUPD}	SUPPLYD	X	Supply Voltage, Digital Circuitry
11	GND _D	SUPPLYD	X	Ground, Digital Circuitry
12	GND _{CAP}	SUPPLYD	X	Ground, Digital Decoupling Circuitry
13	SCL	IN/OUT	X	I ² C Bus Clock
14	SDA	IN/OUT	X	I ² C Bus Data

Pin No. PQFP 80-pin	Pin Name	Type	Connection (if not used)	Short Description
15	RESQ	IN	X	Reset Input, Active Low
16	TEST	IN	GND _D	Test Pin, connect to GND _D
17	VGAV	IN	GND _D	VGAV Input
18	YCOEQ	IN	V _{SUPD}	Y/C Output Enable Input, Active Low
19	FFIE	OUT	LV	FIFO Input Enable
20	FFWE	OUT	LV	FIFO Write Enable
21	FFRSTW	OUT	LV	FIFO Reset Write/Read
22	FFRE	OUT	LV	FIFO Read Enable
23	FFOE	OUT	LV	FIFO Output Enable
24	CLK20	IN/OUT	LV	Main Clock Output 20.25 MHz
25	GND _{PA}	SUPPLYD	X	Ground, Pad Decoupling Circuitry
26	V _{SUPPA}	SUPPLYD	X	Supply Voltage, Pad Decoupling Circuitry
27	LLC2	OUT	LV	Double Clock Output
28	LLC1	IN/OUT	LV	Clock Output
29	V _{SUPLLC}	SUPPLYD	X	Supply Voltage, LLC Circuitry
30	GND _{LLC}	SUPPLYD	X	Ground, LLC Circuitry
31	Y7	OUT	GND _Y	Picture Bus Luma (MSB)
32	Y6	OUT	GND _Y	Picture Bus Luma
33	Y5	OUT	GND _Y	Picture Bus Luma
34	Y4	OUT	GND _Y	Picture Bus Luma
35	GND _Y	SUPPLYD	X	Ground, Luma Output Circuitry
36	V _{SUPY}	SUPPLYD	X	Supply Voltage, Luma Output Circuitry
37	Y3	OUT	GND _Y	Picture Bus Luma
38	Y2	OUT	GND _Y	Picture Bus Luma
39	Y1	OUT	GND _Y	Picture Bus Luma
40	Y0	OUT	GND _Y	Picture Bus Luma (LSB)
41	C7	OUT	GND _C	Picture Bus Chroma (MSB)
42	C6	OUT	GND _C	Picture Bus Chroma
43	C5	OUT	GND _C	Picture Bus Chroma
44	C4	OUT	GND _C	Picture Bus Chroma
45	V _{SUPC}	SUPPLYD	X	Supply Voltage, Chroma Output Circuitry

Pin No. PQFP 80-pin	Pin Name	Type	Connection (if not used)	Short Description
46	GND _C	SUPPLYD	X	Ground, Chroma Output Circuitry
47	C3	OUT	GND _C	Picture Bus Chroma
48	C2	OUT	GND _C	Picture Bus Chroma
49	C1	OUT	GND _C	Picture Bus Chroma
50	C0	OUT	GND _C	Picture Bus Chroma (LSB)
51	GND _{SY}	SUPPLYD	X	Ground, Sync Pad Circuitry
52	V _{SUPSY}	SUPPLYD	X	Supply Voltage, Sync Pad Circuitry
53	INTLC	OUT	LV	Interlace Output
54	AVO	OUT	LV	Active Video Output
55	FSY/HC	OUT	LV	Front Sync/ Horizontal Clamp Pulse
56	MSY/HS	IN/OUT	LV	Main Sync/Horizontal Sync Pulse
57	VS	OUT	LV	Vertical Sync Pulse
58	FPDAT	IN/OUT	LV	Front-End/Back-End Data
59	V _{STBY}	SUPPLYA	X	Standby Supply Voltage
60	CLK5	OUT	LV	CCU 5 MHz Clock Output
62	XTAL1	IN	X	Analog Crystal Input
63	XTAL2	OUT	X	Analog Crystal Output
64	ASGF		X	Analog Shield GND _F
65	GND _F	SUPPLYA	X	Ground, Analog Front-End
66	VRT	OUTPUT	X	Reference Voltage Top, Analog
67	I2CSEL	IN	X	I ² C Bus Address Select
68	ISGND	SUPPLYA	X	Signal Ground for Analog Input, connect to GND _F
69	V _{SUPF}	SUPPLYA	X	Supply Voltage, Analog Front-End
70	VOUT	OUT	LV	Analog Video Output
71	CIN	IN	LV*	Chroma / Analog Video 5 Input
72	VIN1	IN	VRT*	Video 1 Analog Input
73	VIN2	IN	VRT	Video 2 Analog Input
74	VIN3	IN	VRT	Video 3 Analog Input
75	VIN4	IN	VRT	Video 4 Analog Input
76	V _{SUPAI}	SUPPLYA	X	Supply Voltage, Analog Component Inputs Front-End

Pin No. PQFP 80-pin	Pin Name	Type	Connection (if not used)	Short Description
77	GND _{AI}	SUPPLYA	X	Ground, Analog Component Inputs Front-End
78	VREF	OUTPUT	X	Reference Voltage Top, Analog Component Inputs Front-End
79	FB1IN	IN	VREF	Fast Blank Input
80	AISGND	SUPPLYA	X	Signal Ground for Analog Component Inputs, connect to GND _{AI}
8, 61	NC	–	LV OR GND _D	Not connected

*) chroma selector must be set to 1 (CIN chroma select)

4.3. Pin Descriptions (pin numbers for PQFP80 package)

Pins 1-3 – Analog Component Inputs RGB1/YC_rC_b1 (Fig. 4–11)

These are analog component inputs with fast blank control. A RGB or YC_rC_b signal is converted using the component AD converter. The input signals must be AC-coupled.

Pins 4-6 – Analog Component Inputs RGB2/YC_rC_b2 (Fig. 4–11)

These are analog component inputs without fastblank control. A RGB or YC_rC_b signal is converted using the component AD converter. The input signals must be AC-coupled.

Pin 7, 64 – Ground, Analog Shield Front-End GND_F

Pin 9 – Supply Voltage, Decoupling Circuitry V_{SUPCAP}
This pin is connected with 220 nF/1.5 nF/390 pF to GND_{CAP}.

Pin 10 – Supply Voltage, Digital Circuitry V_{SUPD}

Pin 11 – Ground, Digital Circuitry GND_D

Pin 12 – Ground, Decoupling Circuitry GND_{CAP}

Pin 13– I²C Bus Clock SCL (Fig. 4–3)
This pin connects to the I²C bus clock line.

Pin 14– I²C Bus Data SDA (Fig. 4–12)
This pin connects to the I²C bus data line.

Pin 15 – Reset Input RESQ (Fig. 4–3)
A low level on this pin resets the VPC 32xx.

Pin 16 – Test Input TEST (Fig. 4–3)
This pin enables factory test modes. For normal operation, it must be connected to ground.

Pin 17 – VGAV-Input (Fig. 4–3)

This pin is connected to the vertical sync signal of a VGA signal.

Pin 18 – YC Output Enable Input YCOEQ (Fig. 4–3)

A low level on this pin enables the luma and chroma outputs.

Pin 19 – FIFO Input Enable FFIE (Fig. 4–4)

This pin is connected to the IE pin of the external field memory.

Pin 20 – FIFO Write Enable FFWE (Fig. 4–4)

This pin is connected to the WE pin of the external field memory.

Pin 21 – FIFO Reset Write/Read FFRSTW (Fig. 4–4)

This pin is connected to the RSTW pin of the external field memory.

Pin 22 – FIFO Read Enable FFRE (Fig. 4–4)

This pin is connected to the RE pin of the external field memory.

Pin 23 – FIFO Output Enable FFOE (Fig. 4–4)

This pin is connected to the OE pin of the external field memory.

Pin 24 – Main Clock Output CLK20 (Fig. 4–4)

This is the 20.25 MHz main clock output.

Pin 25 – Ground, Analog Pad Circuitry GND_{PA}

Pin 26 – Supply Voltage, Analog Pad Circuitry V_{SUPPA}
This pin is connected with 47 nF/1.5 nF to GND_{PA}

Pin 27 – Double Output Clock, LLC2 (Fig. 4–4)

Pin 28 – Output Clock, LLC1 (Fig. 4–4)

This is the clock reference for the luma, chroma, and status outputs.

Pin 29 – Supply Voltage, LLC Circuitry V_{SUPLLC}
This pin is connected with 68 nF to GND_{LLC}

Pin 30 – Ground, LLC Circuitry GND_{LLC}

Pins 31 to 34, 37 to 40 – Luma Outputs Y7 – Y0 (Fig. 4–4)

These output pins carry the digital luminance data. The outputs are clocked with the LLC1 clock. In ITUR656 mode the Y/C data is multiplexed and clocked with LLC2 clock.

Pin 35 – Ground, Luma Output Circuitry GND_Y
This pin is connected with 68 nF to GND_Y

Pin 36 – Supply Voltage, Luma Output Circuitry V_{SUPY}

Pins 41 to 44, 47 to 50 – Chroma Outputs C7–C0 (Fig. 4–4) These outputs carry the digital CrCb chrominance data. The outputs are clocked with the LL1 clock. The CrCb data is sampled at half the clock rate and multiplexed. The CrCb multiplex is reset for each TV line. In ITUR656 mode, the chroma outputs are tri-stated.

Pin 45 – Supply Voltage, Chroma Output Circuitry V_{SUPC}
This pin is connected with 68 nF to GND_C

Pin 46 – Ground, Chroma Output Circuitry GND_C

Pin 51 – Ground, Sync Pad Circuitry GND_{SY}

Pin 52 – Supply Voltage, Sync Pad Circuitry V_{SUPSY}
This pin is connected with 47 nF/1.5 nF to GND_{SY}

Pin 53 – Interlace Output, INTLC (Fig. 4–4)
This pin supplies the interlace information, 0 indicates first field, 1 indicates second field.

Pin 54 – Active Video Output, AVO (Fig. 4–4)
This pin indicates the active video output data. The signal is clocked with the LLC1 clock.

Pin 55 – Front Sync/Horizontal Clamp Pulse, FSY/HC (Fig. 4–4)
This signal can be used to clamp an external video signal, that is synchronous to the input signal. The timing is programmable. In DIGIT3000 mode, this pin supplies the front sync information.

Pin 56 – Main Sync/Horizontal Sync Pulse MSY/HS (Fig. 4–4)
This pin supplies the horizontal sync pulse information in line-locked mode. In DIGIT3000 mode, this pin is the main sync input.

Pin 57 – Vertical Sync Pulse, VS (Fig. 4–4)
This pin supplies the vertical sync signal.

Pin 58 – Front-End/Back-End Data FPDAT (Fig. 4–5)
This pin interfaces to the DDP 3300A back-end pro-

cessor. The information for the deflection drives and for the white drive control, i. e. the beam current limiter, is transmitted by this pin.

Pin 59 – Standby Supply Voltage V_{STDBY}
In standby mode, only the clock oscillator is active, GND_F should be ground reference. Please activate RESQ before powering-up other supplies

Pin 60 – CCU 5 MHz Clock Output CLK5 (Fig. 4–10)
This pin provides a clock frequency for the TV microcontroller, e.g. a CCU 3000 controller. It is also used by the DDP 3300A display controller as a standby clock.

Pins 62 and 63 – XTAL1 Crystal Input and XTAL2 Crystal Output (Fig. 4–7)
These pins are connected to an 20.25 MHz crystal oscillator which is digitally tuned by integrated shunt capacitances. The CLK20 and CLK5 clock signals are derived from this oscillator. An external clock can be fed into XTAL1. In this case, clock frequency adjustment must be switched off.

Pin 65 – Ground, Analog Front-End GND_F

Pin 66 – Reference Voltage Top VRT (Fig. 4–8)
Via this pin, the reference voltage for the A/D converters is decoupled. The pin is connected with 10 μF /47 nF to the Signal Ground Pin.

Pin 67 – I²C Bus address select I2CSEL
This pin determines the I²C bus address of the IC.

Table 4–1: VPC32xxD I²C address select

I2CSEL	I ² C Add.
GND_F	88/89 hex
VRT	8C/8D hex
V_{SUPF}	8E/8F hex

Pin 68 – Signal GND for Analog Input ISGND (Fig. 4–10) This is the high quality ground reference for the video input signals.

Pin 69 – Supply Voltage, Analog Front-End V_{SUPF} (Fig. 4–8)
This pin is connected with 220 nF/1.5 nF/390 pF to GND_F

Pin 70 – Analog Video Output, VOUT (Fig. 4–6)
The analog video signal that is selected for the main (luma, CVBS) ADC is output at this pin. An emitter follower is required at this pin.

Pin 71 – Chroma Input CIN (Fig. 4–9)
This pin is connected to the S-VHS chroma signal. A resistive divider is used to bias the input signal to the middle of the converter input range. CIN can only be

connected to the chroma (Video 2) A/D converter. The signal must be AC-coupled.

Pins 72-75 – Video Input 1–4 (Fig. 4–11)

These are the analog video inputs. A CVBS or S-VHS luma signal is converted using the luma (Video 1) AD converter. The VIN1 input can also be switched to the chroma (Video 2) ADC. The input signal must be AC-coupled.

Pin 76 – Supply Voltage, Analog Component Inputs Front-End V_{SUPAI}

This pin is connected with 220 nF/1.5 nF/390 pF to GND_{AI}

Pin 77 – Ground, Analog Component Inputs Front-End GND_{AI}

Pin 78 – Reference Voltage Top VREF (Fig. 4–8)

Via this pin, the reference voltage for the analog component A/D converters is decoupled. The pin is connected with 10 μ F/47 nF to the Analog Component Signal Ground Pin.

Pin 79 – Fast Blank Input FB1IN (Fig. 4–10)

This pin is connected to the analog fast blank signal. It controls the insertion of the RGB1/YC_rC_b1 signals. The input signal must be DC-coupled.

Pin 80 – Signal GND for Analog Component Inputs AISGND (Fig. 4–10)

This is the high quality ground reference for the component input signals.

4.4. Pin Configuration

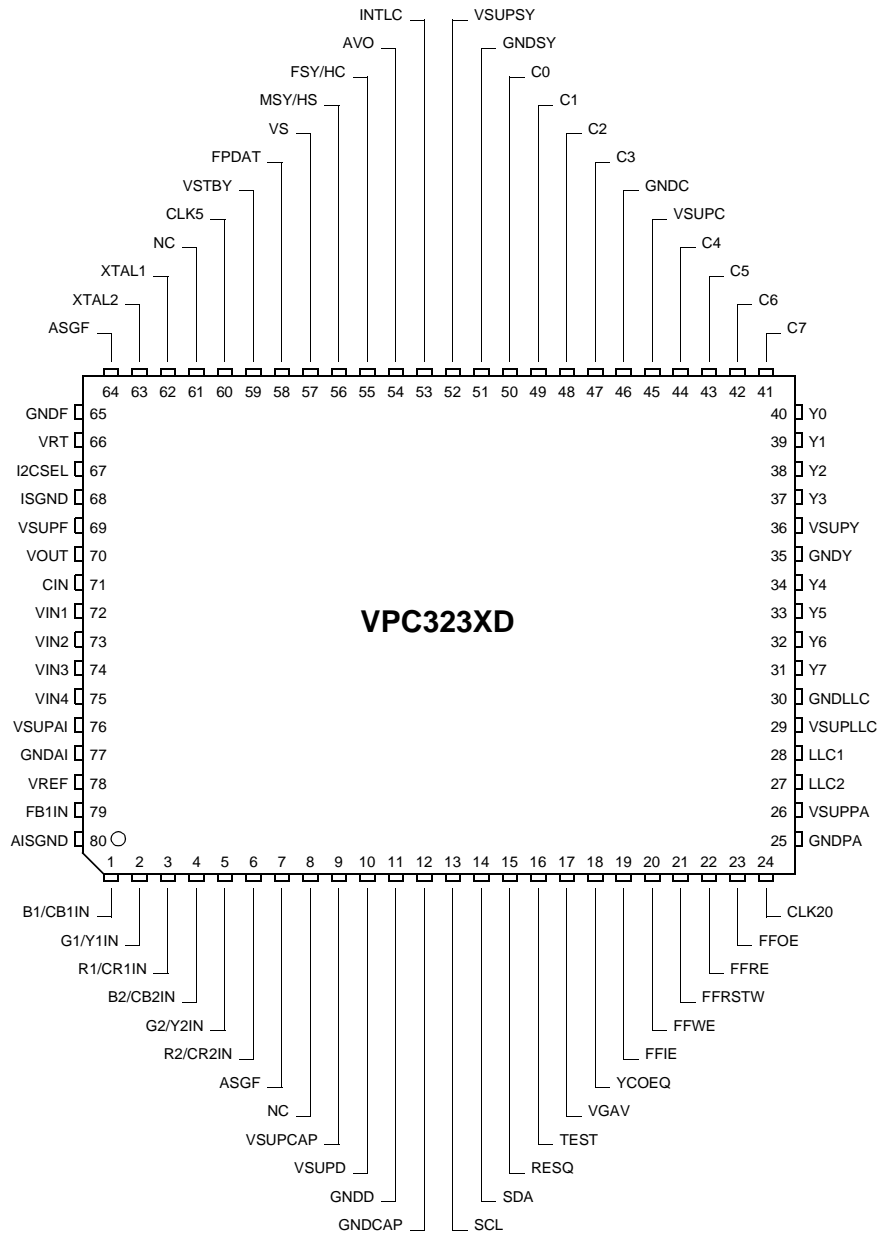

Fig. 4-2: 80-pin PQFP package

4.5. Pin Circuits

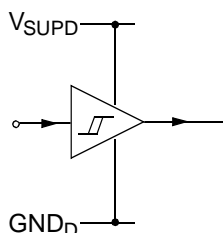

Fig. 4-3: Input pins RESQ, TEST, VGAV, YCOEQ

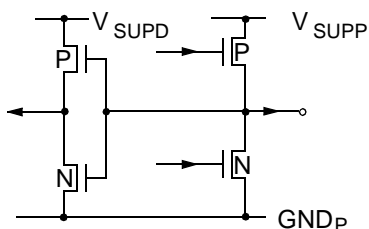

Fig. 4-4: Output pins C0-C7, Y0-Y7, FSY, MSY, HC, AVO, VS, INTLC, HS, LLC1, LLC2, CLK20, FFWE, FFIE, FFRD, RSTWR

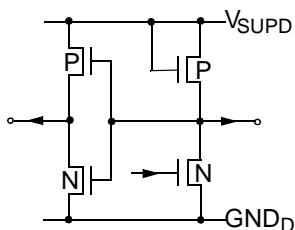

Fig. 4-5: Input/Output pin FPDAT

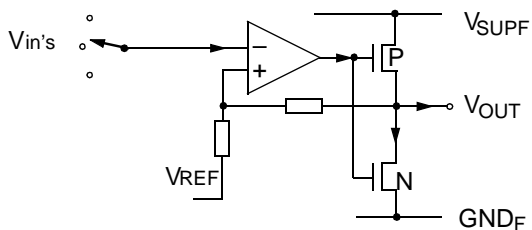

Fig. 4-6: Output pin VOUT

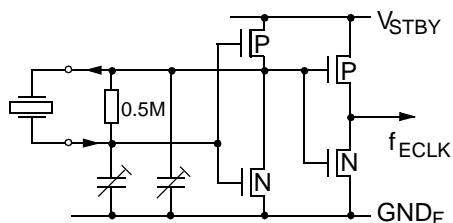

Fig. 4-7: Input/Output Pins XTAL1, XTAL2

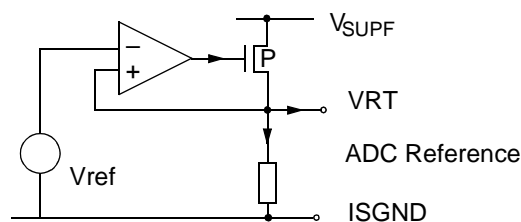

Fig. 4-8: Pins VRT, ISGND and VREF, AISGND

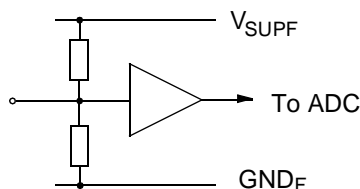

Fig. 4-9: Chroma input CIN

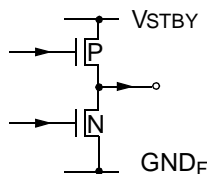

Fig. 4-10: Output pin CLK5

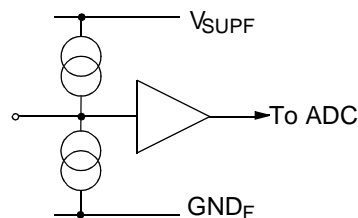

Fig. 4-11: Input pins VIN1-VIN4, RGB/YC_rCb1/2, FB1IN

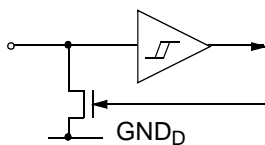

Fig. 4-12: Pins SDA, SCL

4.6. Electrical Characteristics

4.6.1. Absolute Maximum Ratings

Symbol	Parameter	Pin No.	Min.	Max.	Unit
T_A	Ambient Operating Temperature	–	0	65	°C
T_S	Storage Temperature	–	–40	125	°C
$V_{S\text{UPA/D}}$	Supply Voltage, all Supply Inputs		–0.3	6	V
V_I	Input Voltage, all Inputs		–0.3	$V_{S\text{UPA}}+0.3$	V
V_O	Output Voltage, all Outputs		–0.3	$V_{S\text{UPD}}+0.3$	V

Stresses beyond those listed in the “Absolute Maximum Ratings” may cause permanent damage to the device. This is a stress rating only. Functional operation of the device at these or any other conditions beyond those indicated in the “Recommended Operating Conditions/Characteristics” of this specification is not implied. Exposure to absolute maximum ratings conditions for extended periods may affect device reliability.

4.6.2. Recommended Operating Conditions

Symbol	Parameter	Pin Name	Min.	Typ.	Max.	Unit
T_A	Ambient Operating Temperature	–	0	–	65	°C
$V_{S\text{UP}}$	Supply Voltages, all analog Supply Pins		4.75	5.0	5.25	V
$V_{S\text{UPD}}$	Supply Voltages, all digital Supply Pins		3.15	3.3	3.45	V
f_{XTAL}	Clock Frequency	XTAL1/2	–	20.25	–	MHz

4.6.3. Recommended Crystal Characteristics

Symbol	Parameter	Min.	Typ.	Max.	Unit
T _A	Operating Ambient Temperature	0	–	65	°C
f _P	Parallel Resonance Frequency with Load Capacitance C_L = 13 pF	–	20.250000	–	MHz
Δf _P /f _P	Accuracy of Adjustment	–	–	±20	ppm
Δf _P /f _P	Frequency Temperature Drift	–	–	±30	ppm
R _R	Series Resistance	–	–	25	Ω
C ₀	Shunt Capacitance	3	–	7	pF
C ₁	Motional Capacitance	20	–	30	fF
Load Capacitance Recommendation					
C _{Lext}	External Load Capacitance ¹⁾ from pins to Ground (pin names: Xtal1 Xtal2)	–	3.3	–	pF
DCO Characteristics ^{2,3)}					
C _{ICLoadmin}	Effective Load Capacitance @ min. DCO–Position, Code 0, package: 68PLCC	3	4.3	5.5	pF
C _{ICLoadrng}	Effective Load Capacitance Range, DCO Codes from 0..255	11	12.7	15	pF
<p>1) Remarks on defining the External Load Capacitance: External capacitors at each crystal pin to ground are required. They are necessary to tune the effective load capacitance of the PCBs to the required load capacitance C_L of the crystal. The higher the capacitors, the lower the clock frequency results. The nominal free running frequency should match f_P MHz. Due to different layouts of customer PCBs the matching capacitor size should be determined in the application. The suggested value is a figure based on experience with various PCB layouts. Tuning condition: Code DVCO Register=–720</p> <p>2) Remarks on Pulling Range of DCO: The pulling range of the DCO is a function of the used crystal and effective load capacitance of the IC (C_{ICLoad} + C_{LoadBoard}). The resulting frequency f_L with an effective load capacitance of C_{Leff} = C_{ICLoad} + C_{LoadBoard} is:</p> $f_L = f_P * \frac{1 + 0.5 * [C_1 / (C_0 + C_L)]}{1 + 0.5 * [C_1 / (C_0 + C_{Leff})]}$ <p>3) Remarks on DCO codes The DCO hardware register has 8 bits, the fp control register uses a range of –2048...2047</p>					

4.6.4. Characteristics

at $T_A = 0$ to 65 °C, $V_{SUPP} = 4.75$ to 5.25 V, $V_{SUPD} = 3.15$ to 3.45 V $f = 20.25$ MHz for min./max. values
 at $T_C = 60$ °C, $V_{SUPP} = 5$ V, $V_{SUPD} = 3.3$ V $f = 20.25$ MHz for typical values

Symbol	Parameter	Pin Name	Min.	Typ.	Max.	Unit
P_{TOT}	Total Power Dissipation		–	tbd	1.4	W
I_{VSUPA}	Current Consumption	V_{SUPP}	–	tbd	160	mA
I_{VSUPD}	Current Consumption	V_{SUPD}	–	tbd	190	mA
I_{VSTDBY}	Current Consumption	V_{STDBY}	–	1	–	mA
IL	Input / Output Leakage Current	All I/O Pins	–1	–	1	μ A

4.6.4.1. Characteristics, 5 MHz Clock Output

Symbol	Parameter	Pin Name	Min.	Typ.	Max.	Unit	Test Conditions
V_{OL}	Output Low Voltage	CLK5	–	–	0.4	V	$I_{OL} = 0.4$ mA
V_{OH}	Output High Voltage		4.0	–	V_{STDBY}	V	$-I_{OL} = 0.9$ mA
t_{OT}	Output Transition Time		–	50	–	ns	$C_{LOAD} = 30$ pF

4.6.4.2. Characteristics, 20 MHz Clock Input/Output, External Clock Input (XTAL1)

Symbol	Parameter	Pin Name	Min.	Typ.	Max.	Unit	Test Conditions
V_{DCAV}	DC Average	CLK20	$V_{SUPD}/2 - 0.3$	$V_{SUPD}/2$	$V_{SUPD}/2 + 0.3$	V	$C_{LOAD} = 30$ pF
V_{PP}	V_{OUT} Peak to Peak		$V_{SUPD}/2 - 0.3$	$V_{SUPD}/2$	$V_{SUPD}/2 + 0.3$	V	$C_{LOAD} = 30$ pF
t_{OT}	Output Transition Time		–	–	18	ns	$C_{LOAD} = 30$ pF
V_{IT}	Input Trigger Level		2.1	2.5	2.9	V	only for test purposes
V_I	Clock Input Voltage	XTAL1	1.3	–	–	V_{PP}	capacitive coupling used, XTAL2 open

4.6.4.3. Characteristics, Reset Input, Test Input, VGAV Input, YCOEQ Input

Symbol	Parameter	Pin Name	Min.	Typ.	Max.	Unit	Test Conditions
V_{IL}	Input Low Voltage	RESQ TEST VGAV YCOEQ	–	–	0.8	V	
V_{IH}	Input High Voltage		2.0	–	–	V	

4.6.4.4. Characteristics, Power-up Sequence

Symbol	Parameter	Pin Name	Min.	Typ.	Max.	Unit	Test Conditions
t_{Vdel}	Ramp Up Difference of Supplies		tbd	-	tbd	ms	
t_{Vrmp}	Transition Time of Supplies		-	-	50	ms	

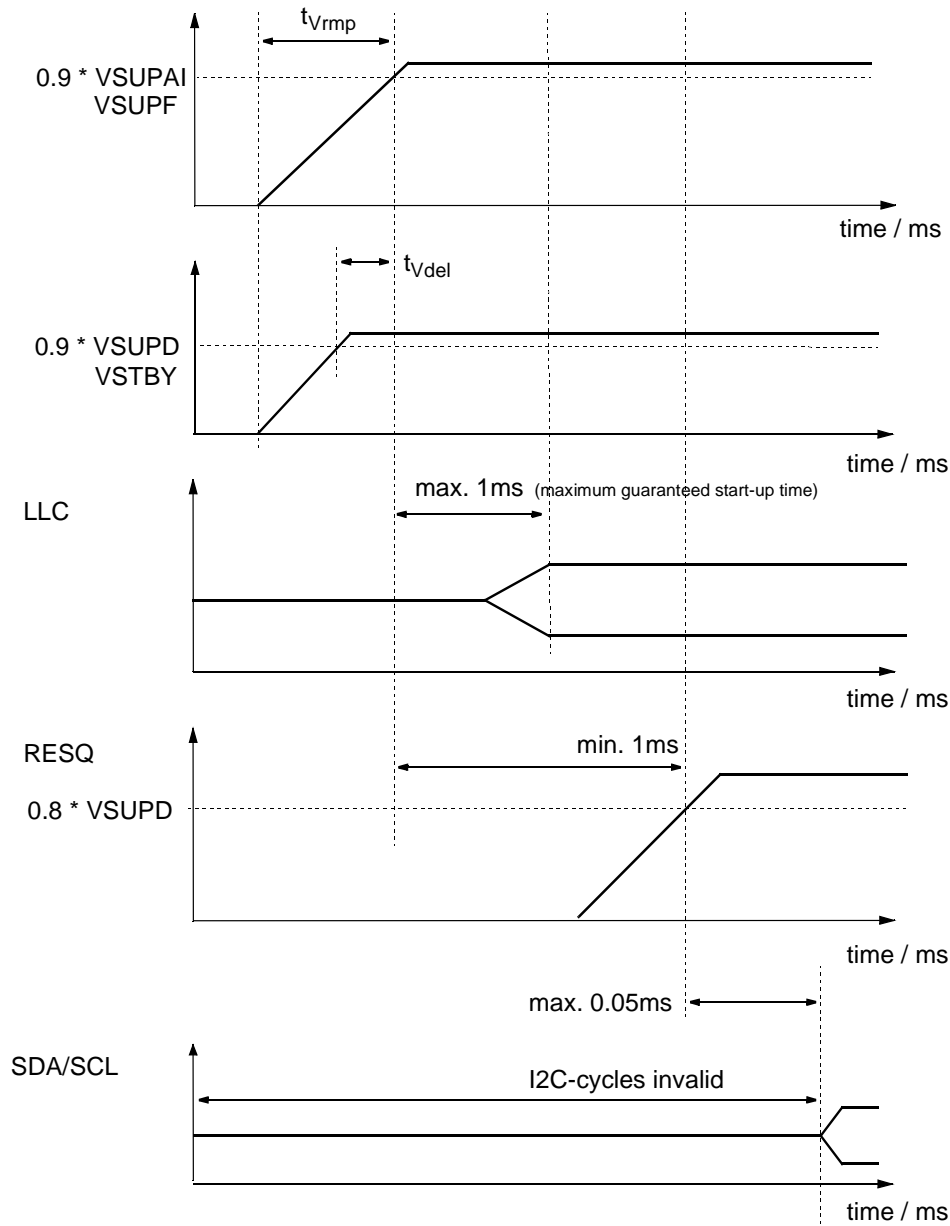

Fig. 4-13: Power-Up sequence

4.6.4.5. Characteristics, FPDAT Input/Output

Symbol	Parameter	Pin Name	Min.	Typ.	Max.	Unit	Test Conditions
V_{OL}	Output Low Voltage	FPDAT	–	–	0.5	V	$I_{OL} = 4.0 \text{ mA}$
t_{OH}	Output Hold Time		6	–	–	ns	
t_{ODL}	Output Delay Time		–	–	35	ns	$C_L = 40 \text{ pF}$
V_{IL}	Input Low Voltage		–	–	0.8	V	
V_{IH}	Input High Voltage		1.5	–	–	V	
t_{IS}	Input Setup Time		7	–	–	ns	
t_{IH}	Input Hold Time		5	–	–	ns	
C_L	Load capacitance			–		40	pF

4.6.4.6. Characteristics, I²C Bus Interface

Symbol	Parameter	Pin Name	Min.	Typ.	Max.	Unit	Test Conditions
V_{IL}	Input Low Voltage	SDA, SCL	–	–	1.0	V	
V_{IH}	Input High Voltage		2.0	–	–	V	
V_{OL}	Output Low Voltage		–	–	0.4 0.6	V V	$I_I = 3 \text{ mA}$ $I_I = 6 \text{ mA}$
V_{IH}	Input Capacitance		–	–	5	pF	
t_F	Signal Fall Time		–	–	300	ns	$C_L = 400 \text{ pF}$
t_R	Signal Rise Time		–	–	300	ns	$C_L = 400 \text{ pF}$
f_{SCL}	Clock Frequency	SCL	0	–	400	kHz	
t_{LOW}	Low Period of SCL		1.3	–	–	μs	
t_{HIGH}	High Period of SCL		0.6	–	–	μs	
$t_{SU \text{ Data}}$	Data Set Up Time to SCL high	SDA	100	–	–	ns	
$t_{HD \text{ Data}}$	DATA Hold Time to SCL low		0	–	0.9	μs	

4.6.4.7. Characteristics, Analog Video and Component Inputs

Symbol	Parameter	Pin Name	Min.	Typ.	Max.	Unit	Test Conditions
V _{VIN}	Analog Input Voltage	VIN1, VIN2 VIN3, VIN4 CIN R1/CR1IN G1/Y1IN B1/CB1IN R2/CR2IN G2/Y2IN B2/CB2IN	0	–	3.5	V	
C _{CP}	Input Coupling Capacitor Video Inputs	VIN1, VIN2 VIN3, VIN4	–	680	–	nF	
C _{CP}	Input Coupling Capacitor Chroma Input	CIN	–	1	–	nF	
C _{CP}	Input Coupling Capacitor Component Input	R1/CR1IN G1/Y1IN B1/CB1IN R2/CR2IN G2/Y2IN B2/CB2IN	–	220	–	nF	

4.6.4.8. Characteristics, Analog Front-End and ADCs

Symbol	Parameter	Pin Name	Min.	Typ.	Max.	Unit	Test Conditions
V _{VRT}	Reference Voltage Top	VRT VREF	2.4	2.5	2.6	V	10 μF/10 nF, 1 GΩ Probe
Luma – Path							
R _{VIN}	Input Resistance	VIN1 VIN2	1			MΩ	Code Clamp–DAC=0
C _{VIN}	Input Capacitance	VIN3 VIN4			4.5	pF	
V _{VIN}	Full Scale Input Voltage	VIN1 VIN2	1.8	2.0	2.2	V _{PP}	min. AGC Gain
V _{VIN}	Full Scale Input Voltage	VIN3 VIN4	0.5	0.6	0.7	V _{PP}	max. AGC Gain
AGC	AGC step width			0.166		dB	6-Bit Resolution= 64 Steps f _{sig} =1MHz, – 2 dBr of max. AGC–Gain
DNL _{AGC}	AGC Differential Non-Linearity				±0.5	LSB	
V _{VINCL}	Input Clamping Level, CVBS	VIN1 VIN2 VIN3 VIN4		1.0		V	Binary Level = 64 LSB min. AGC Gain
Q _{CL}	Clamping DAC Resolution		–16		15	steps	5 Bit – I–DAC, bipolar V _{VIN} =1.5 V
I _{CL–LSB}	Input Clamping Current per step		0.7	1.0	1.3	μA	
DNL _{ICL}	Clamping DAC Differential Non-Linearity				±0.5	LSB	

Symbol	Parameter	Pin Name	Min.	Typ.	Max.	Unit	Test Conditions	
Chroma – Path								
R _{CIN}	Input Resistance SVHS Chroma	CIN VIN1	1.4	2.0	2.6	kΩ		
V _{CIN}	Full Scale Input Voltage, Chroma		1.08	1.2	1.32	V _{PP}		
V _{CINDC}	Input Bias Level, SVHS Chroma		–	1.5	–	V		
	Binary Code for Open Chroma Input			128				
Component – Path								
R _{VIN}	Input Resistance	R1/CR1IN G1/Y1IN B1/CB1IN R2/CR2IN G2/Y2IN B2/CB2IN	1			MΩ	Code Clamp–DAC=0	
C _{VIN}	Input Capacitance				4.5	pF		
V _{VIN}	Full Scale Input Voltage		0.85	1.0	1.1	V _{PP}	min. Gain (XAR=-0)	
V _{VIN}	Full Scale Input Voltage		1.2	1.4	1.6	V _{PP}	max. Gain (XAR=-1)	
V _{VINCL}	Input Clamping Level RGB, Y			1.06		V	Binary Level = 16 LSB XAR=-0	
V _{VINCL}	Input Clamping Level Cr, Cb			1.5		V	Binary Level = 128 LSB XAR=-0	
	Gain Match			2.0	tbd	%	Full Scale at 1 MHz, XAR=-0	
Q _{CL}	Clamping DAC Resolution			–32		31	steps	6 Bit – I–DAC, bipolar V _{VIN} =1.5 V
I _{CL-LSB}	Input Clamping Current per step			0.59	0.85	1.11	μA	
DNL _{ICL}	Clamping DAC Differential Non- Linearity					±0.5	LSB	
Dynamic Characteristics for all Video-Paths (Luma + Chroma) and Component-Paths								
BW	Bandwidth	VIN1 VIN2 VIN3 VIN4 R1/CR1IN G1/Y1IN B1/CB1IN R2/CR2IN G2/Y2IN B2/CB2IN	8	10		MHz	–2 dBr input signal level	
XTALK	Crosstalk, any Two Video Inputs			–56	–tbd		dB	1 MHz, –2 dBr signal level
THD	Total Harmonic Distortion			–50	–tbd		dB	1 MHz, 5 harmonics, –2 dBr signal level
SINAD	Signal to Noise and Distortion Ratio			tbd	45		dB	1 MHz, all outputs, –2 dBr signal level
INL	Integral Non-Linearity					±1tbd	LSB	Code Density, DC-ramp
DNL	Differential Non-Linearity					±0.8	LSB	
DG	Differential Gain					±3	%	–12 dBr, 4.4 MHz signal on DC-ramp
DP	Differential Phase					1.5	deg	

Symbol	Parameter	Pin Name	Min.	Typ.	Max.	Unit	Test Conditions
Analog Video Output							
V _{OUT}	Output Voltage	Out: VOUT In: VIN1 VIN2 VIN3 VIN4	1.7	2.0	2.3	V _{PP}	V _{IN} = 1 V _{PP} AGC= 0 dB
AGC _{VOUT}	AGC step width, VOUT			1.333		dB	3 Bit Resolution=7 Steps 3 MSB's of main AGC
DNL _{AGC}	AGC Differential Non-Linearity				±0.5	LSB	
V _{OUTDC}	DC-level			1		V	clamped to Back porch
BW	V _{OUT} Bandwidth			8	10		MHz
THD	V _{OUT} Total Harmonic Distortion				-40	dB	Input: -2 dB of main ADC range, C _L ≤10 pF 1 MHz, 5 Harmonics
C _{LVOUT}	Load Capacitance	VOUT	-	-	10	pF	
I _{LVOUT}	Output Current			-	-	±0.1	mA

4.6.4.9. Characteristics, Analog FB Input

Symbol	Parameter	Pin Name	Min.	Typ.	Max.	Unit	Test Conditions
R _{FBIN}	Input Resistance	FB1IN	1			MΩ	Code Clamp-DAC=0
V _{FBIN}	Full Scale Input Voltage		0.85	1.0	1.1	V _{PP}	
	Threshold for FB-Monitor		0.5	0.65	0.8	V _{PP}	
BW	Bandwidth		8	10		MHz	-2 dB input signal level
THD	Total Harmonic Distortion			-50	tbd	dB	1 MHz, 5 harmonics, -2 dB signal level
SINAD	Signal to Noise and Distortion Ratio		tbd	37		dB	1 MHz, all outputs, -2 dB signal level
INL	Integral Non-Linearity			0.3	±1	LSB	Code Density, DC-ramp
DNL	Differential Non-Linearity			0.2	±0.8	LSB	

4.6.4.10. Characteristics, Output Pin Specification

Output Specification for SYNC, CONTROL, and DATA Pins:

Y[7:0], C[7:0], AVO, HS, HC, INTLC, VS, FSY, FFIE, FFWE, FFOE, FFRD, FFRSTWR

Symbol	Parameter	Pin Name	Min.	Typ.	Max.	Unit	Test Conditions
V_{OL}	Output Low Voltage		–	–	0.4	V	$C_{load}=50pF$
V_{OH}	Output High Voltage		2.4	–	–	V	$C_{load}=50pF$
t_{OH}	Output Hold Time		20	–	–	ns	LLC1=13.5MHz
t_{OD}	Output Delay Time		–	–	52	ns	LLC1=13.5MHz
t_{OH}	Output Hold Time		10	–	–	ns	LLC2=27.0MHz
t_{OD}	Output Delay Time		–	–	26	ns	LLC2=27.0MHz
C_L	Load Capacitance		–	–	50	pF	

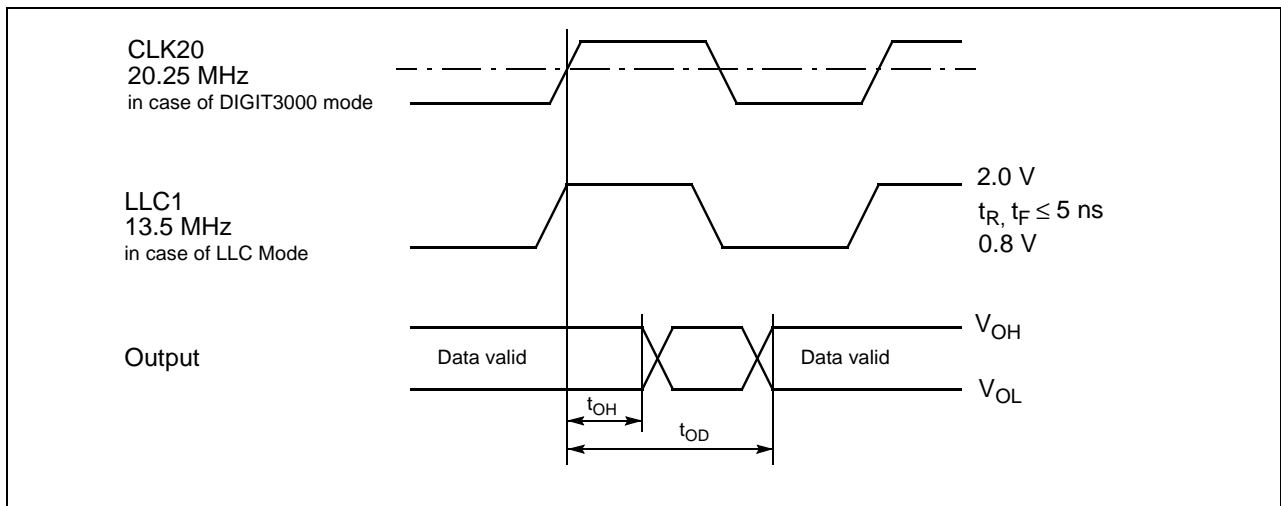

Fig. 4–14: Sync, control, and data outputs

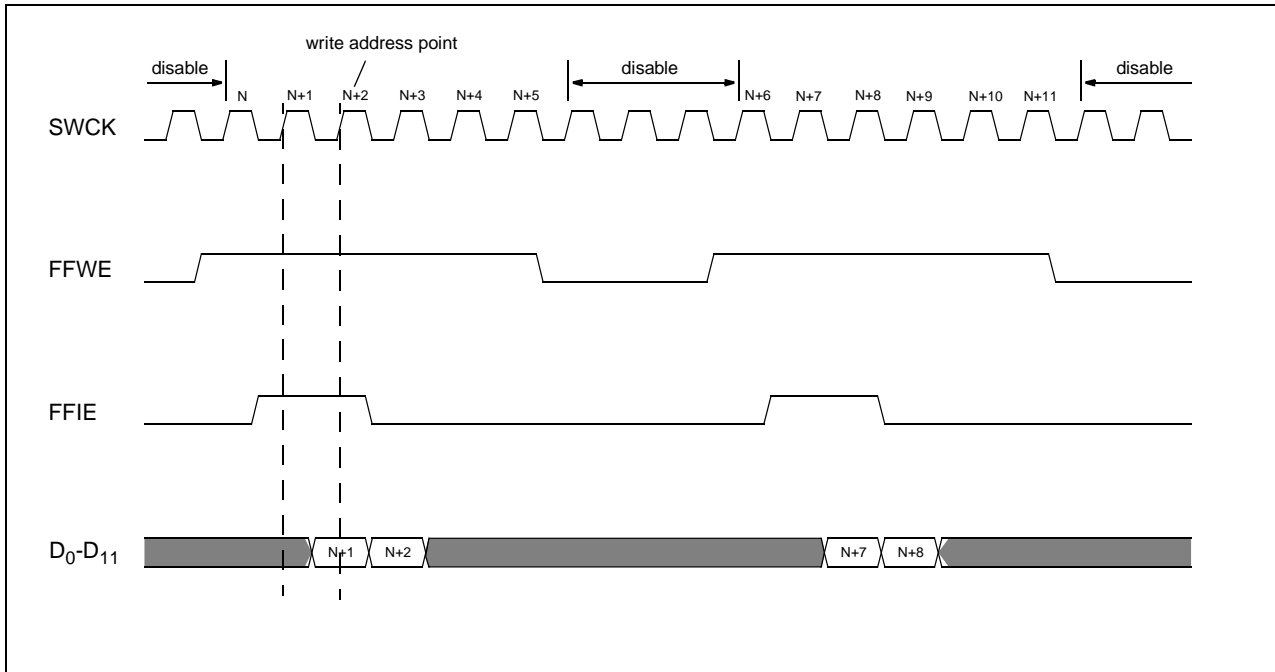

Fig. 4-15: Field memory write cycle timing

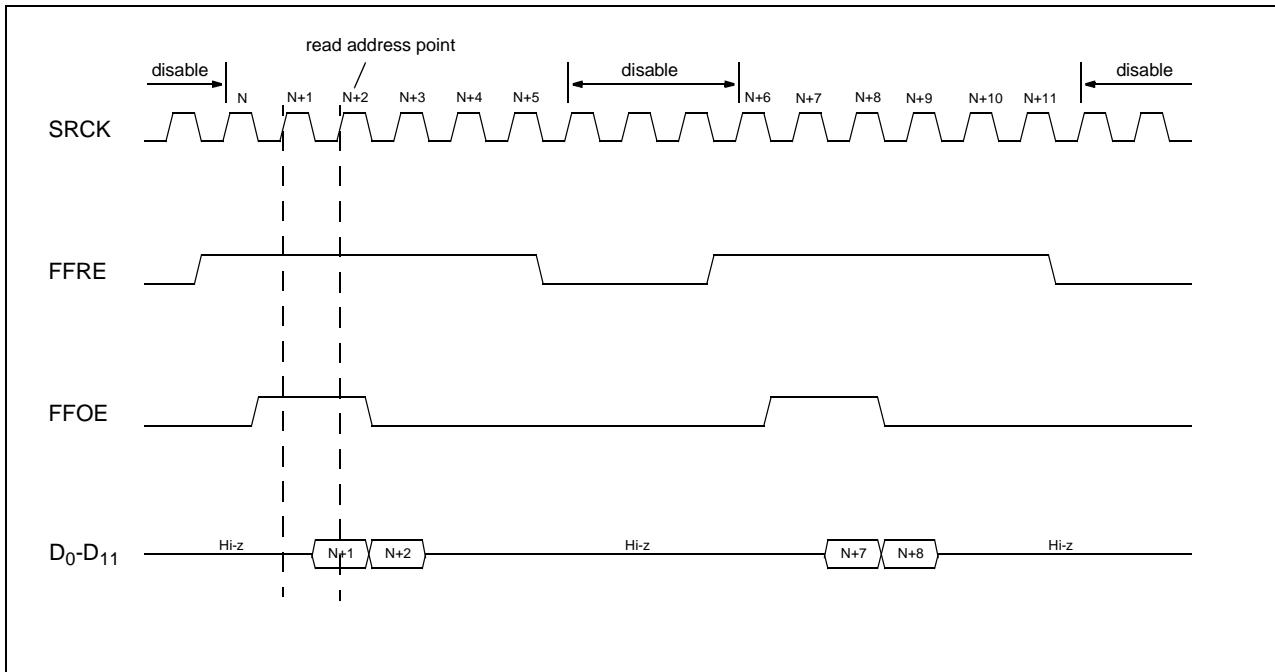

Fig. 4-16: Field memory read cycle timing

4.6.4.11. Characteristics, Input Pin Specification

Input Specification for SYNC, CONTROL, and DATA Pin: MSY (DIGIT3000 mode only)

Symbol	Parameter	Pin Name	Min.	Typ.	Max.	Unit	Test Conditions
V_{IL}	Input Low Voltage		–	–	0.8	V	
V_{IH}	Input High Voltage		1.5	–	–	V	
t_{IS}	Input Setup Time		7	–	–	ns	
t_{IH}	Input Hold Time		5	–	–	ns	

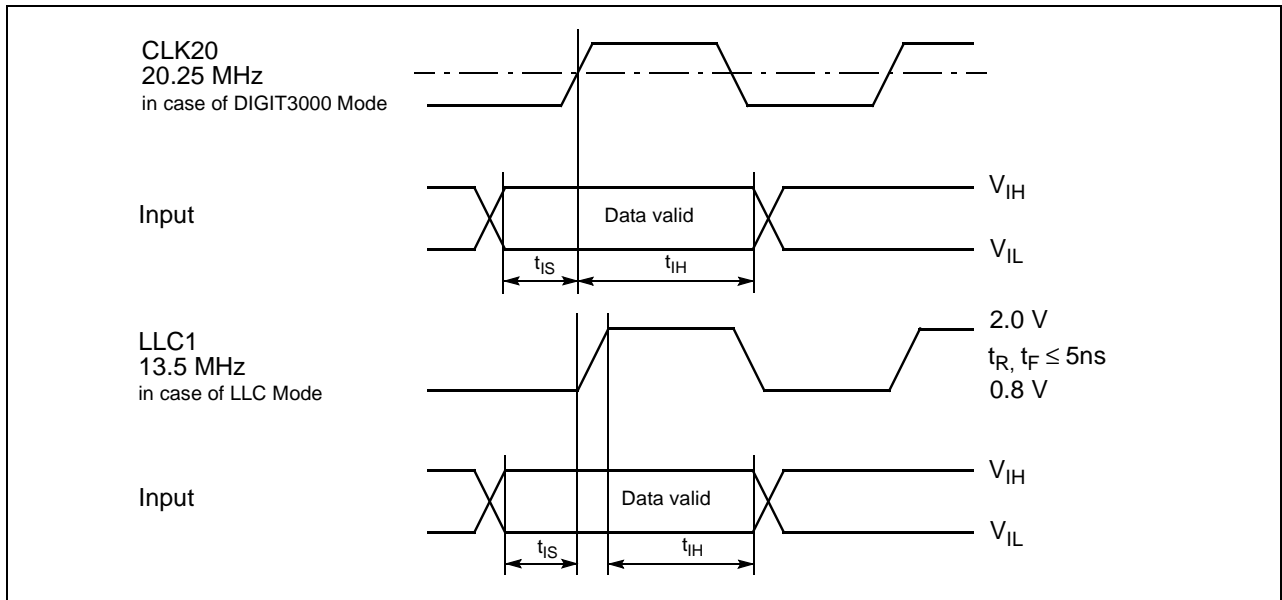

Fig. 4–17: Sync, control, and data inputs

4.6.4.12. Characteristics, Clock Output Specification

Line-Locked Clock Pins: LLC1, LLC2

Symbol	Parameter	Pin Name	Min.	Typ.	Max.	Unit	Test Conditions
CL	Load capacitance		–	–	50	pF	
13.5 MHz Line Locked Clock							
1/T ₁₃	LLC1 Clock Frequency		12.5	–	14.5	MHz	
t _{WL13}	LLC1 Clock Low Time		22	–	–	ns	C _L = 30 pF
t _{WH13}	LLC1 Clock High Time		25	–	–	ns	C _L = 30 pF
1/T ₂₇	LLC2 Clock Frequency		25	–	29	MHz	
t _{WL27}	LLC2 Clock Low Time		5	–	–	ns	C _L = 30 pF
t _{WH27}	LLC2 Clock High Time		10	–	–	ns	C _L = 30 pF
16 MHz Line Locked Clock							
1/T ₁₃	LLC1 Clock Frequency		14.8	–	17.2	MHz	
18 MHz Line Locked Clock							
1/T ₁₃	LLC1 Clock Frequency		16.6	–	19.4	MHz	
common timings – all modes							
t _{SK}	Clock Skew		0	–	4	ns	
t _R , t _F	Clock Rise/Fall TimeClock		–	–	5	ns	LLC1=13.5MHz, C _L = 30 pF
t _R , t _F	Clock Rise/Fall TimeClock		–	–	10	ns	LLC2=27.0MHz, C _L = 30 pF
V _{IL}	Input Low Voltage		–	–	0.8	V	
V _{IH}	Input High Voltage		2.0	–	–	V	
V _{OL}	Output Low Voltage		–	–	0.4	V	I _L = 2 mA
V _{OH}	Output High Voltage		2.4	–	–	V	I _H = -2 mA

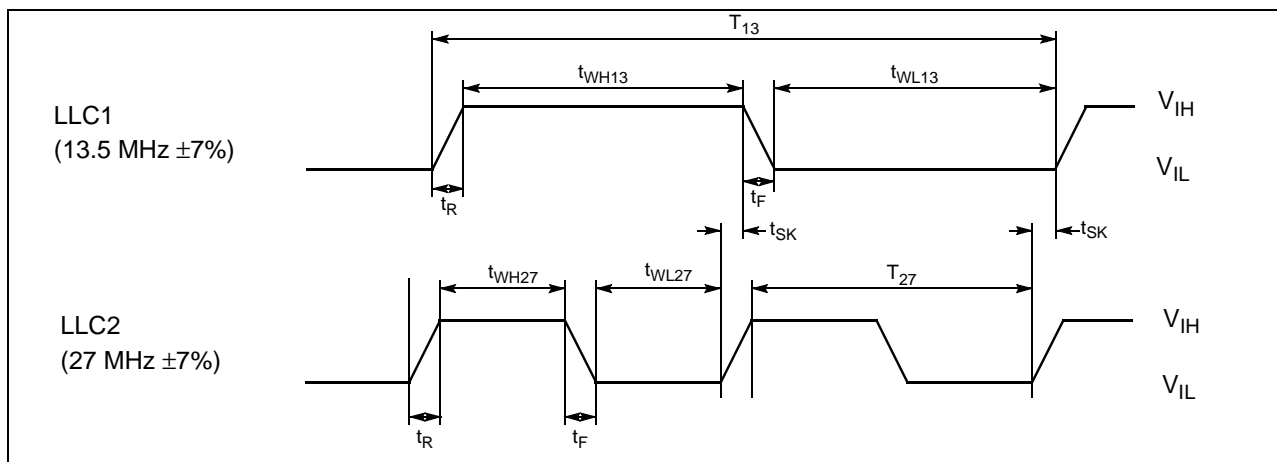
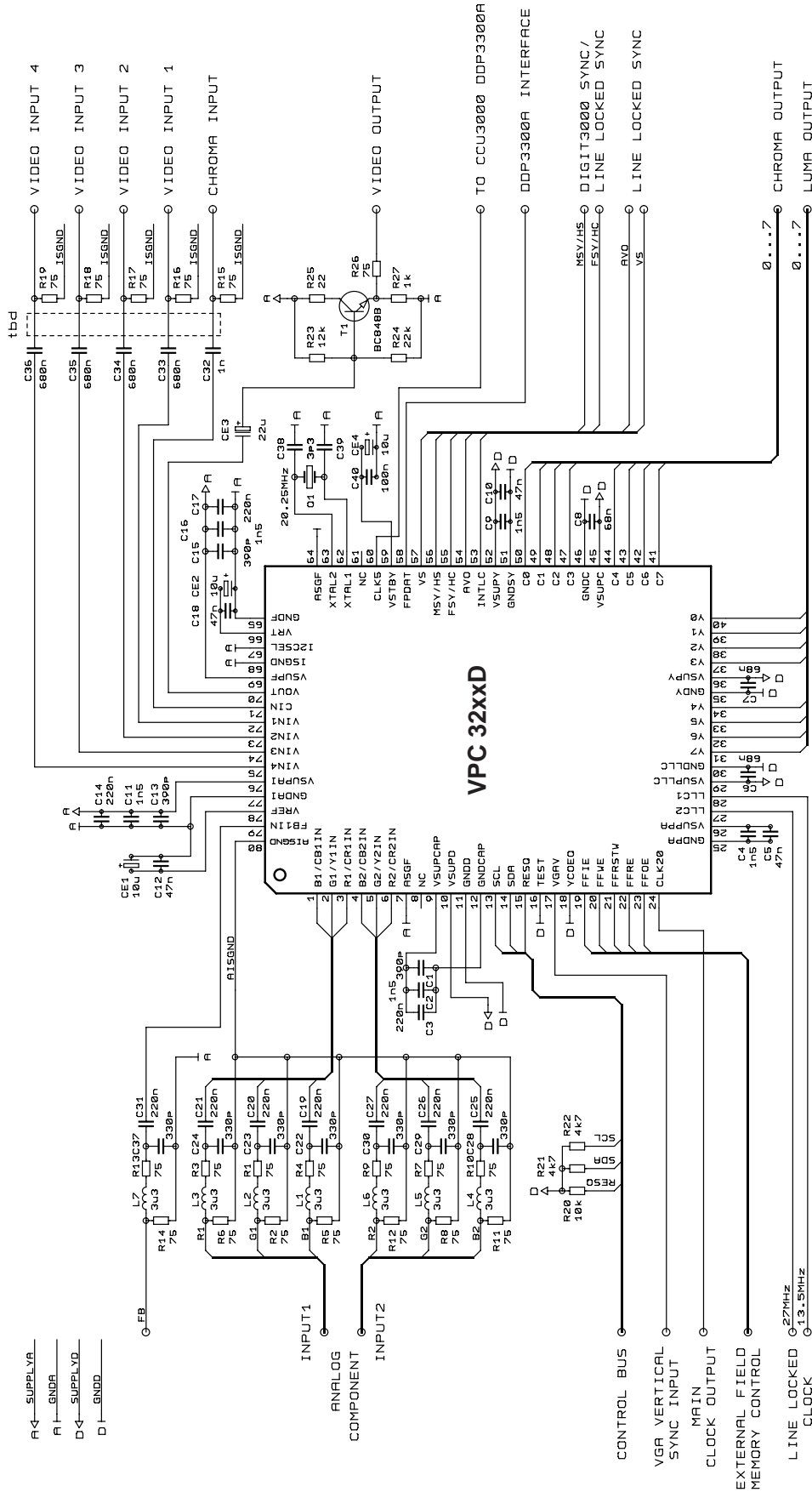

Fig. 4–18: Line-locked clock output pins

5. Application Circuit



5.1. Application Note: VGA mode with VPC 3215C

In 100 Hz TV applications it can be desirable to display a VGA-signal on the TV. In this case a VGA-graphic card delivers the H, V and RGB signals. These signals can be feed "directly" to the backend signal processing. The VPC can generate a stable line locked clock for the 100 Hz system in relation to the VGA sync signals.

While the V-sync is connected to the VGAV pin directly, the H-sync has to be pulse-shaped and amplitude adjusted until it is connected to one of the video input pins of the VPC. The recommended circuitry to filter the H sync is given in the figure below.

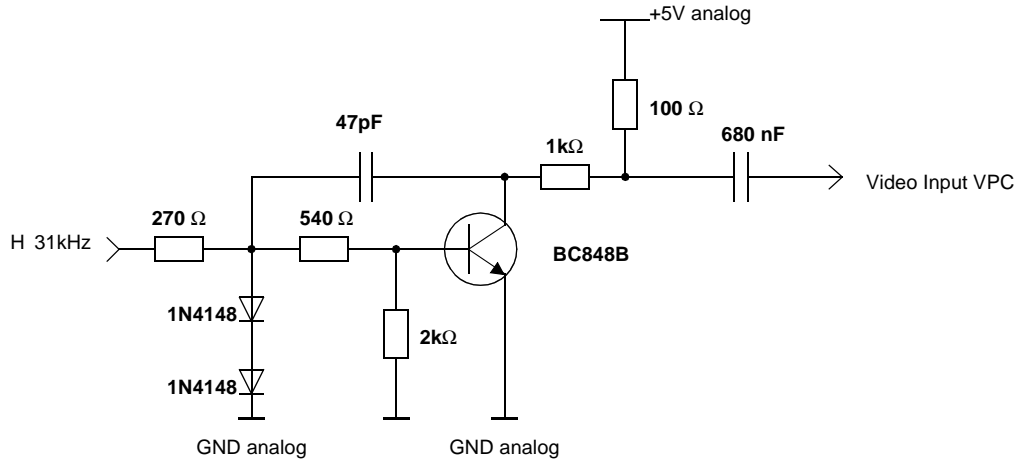

Fig. 5-1: Application circuit for horizontal VGA-input

5.2. Application Note: PIP Mode Programming

5.2.1. Procedure to Program a PIP Mode

For the VPC_{pip} or VPC_{single}:

1. set the scaler according to the PIP size to be used (see Table 2–11).
2. write the registers VPCMODE and PIPMODE according to the mode to be set.
3. in expert mode write the registers NLIN, NPIX and NPFB.
4. write the registers COLBGD, COLFR1, COLFR2, HSTR and VSTR, if a different value as the default one is used.
5. write the registers LINOFFS and PIXOFFS, if a different value as the default one or more than 4 inset pictures in the X or Y direction are used.
6. write the register PIOPER to fill the frame and background of an inset picture. This step is repeated for all inset pictures in a multi PIP application.

For the VPC_{main}:

7. set the scaler to get a full size video (see Table 2–11).
8. write the registers VPCMODE and PIPMODE according to the mode to be set.
9. in expert mode write the registers NLIN, NPIX and NPFB.
10. write the registers COLBGD, HSTR and VSTR, if a different value as the default one is used.
11. write the register PIOPER to start displaying PIP.

For the VPC_{pip} or VPC_{single}:

12. write the register PIOPER to start filling a inset picture with live video.
13. Only for tuner scanning: write the register PIOPER to stop filling a inset picture with live video and changing the channel.
14. repeat steps 12 and 13 for all inset pictures in a multi PIP application.
15. Only for VPC_{single}: write the register PIOPER to start filling the main picture part outside the inset picture(s) with live video.

For the VPC_{main}:

16. write the registers HSTR and VSTR, if the PIP position should be changed.
17. write the register PIOPER, to quit the PIP mode.

In an application with a single VPC, step 7 - 11 and 16 - 17 are dropped. Additionally, the free running mode should be set in the cases shown in Table 2–12.

5.2.2. I²C Registers Programming for PIP Control

To program a PIP mode, the register VPCMODE, PIPMODE and PIOPER should be written always, all other registers are used only in the expert mode or if the default values are modified (see Table 5–1).

Table 5–1: I²C register programing for PIP control

I ² C register	update		
VPCMODE, PIPMODE, PIOPER	should be written always		
COLBGD, COLFR1, COLFR2, HSTR, VSTR	should be written only, if the default values have to be modified		
LINOFFS, PIXOFFS	VPC _{pip}	VPC _{main}	VPC _{single}
	only used in expert mode, when more than 4 inset pictures in the X or Y direction are used.	not used.	only used if a different value as the default one or more than 4 inset pictures in the X or Y direction are used
NLIN, NPIX, NPFB	should be written, only in the expert mode. (In the predefined modes the default values are used.)		

Table 5–2: Limits of the I²C register settings for programming a PIP mode

I ² C register	VPC _{main}	VPC _{pip} and VPC _{single}
NPFB	NPFB ≥ NPIX _{main} + X, (X=2 for TI and X=0 for rest field memories) and NPFB × NLIN _{main} ≤ total field memory size	
NPIX	0 < NPIX ≤ NPFB - X and 0 < NPIX ≤ NPEL _{fp}	0 < NPIX ≤ NPEL _{sp}
NLIN	NPFB × NLIN ≤ total field memory size and 0 ≤ NLIN < NROW _{fp}	0 ≤ NLIN < NROW _{sp}
HSTR	0 ≤ HSTR < NPEL _{fp} - NPIX _{main}	0 ≤ HSTR < NPEL _{sp} - NPIX _{PIP}
VSTR	0 ≤ VSTR < NLIN _{fp} - NLIN _{main}	0 ≤ VSTR < NLIN _{sp} - NLIN _{PIP}
PIXOFFS	not used	0 ≤ PIXOFFS < NPIX _{main} - (number of pixels of inset pictures to the right of PIXOFFS)
LINOFFS	not used	0 ≤ LINOFFS < NLIN _{main} - (number of lines of inset pictures below LINOFFS)

Notes:

- NPIX_{main} and NLIN_{main}: correspond to VPC_{main}
- NPIX_{PIP} and NLIN_{PIP}: correspond to VPC_{single} and VPC_{pip}
- NROW_{fp} and NPEL_{fp}: number of lines per field and number of pixels per line of a full picture (e.g. NROW_{fp}=288, NPEL_{fp}= 720 for PAL at 13.5 MHz)
- NROW_{sp} and NPEL_{sp}: number of lines per field and number of pixels per line of a inset picture

The limits of the I²C register settings are given in Table 5–2. No range check and value limitation are carried out in the field memory controller. An illegal setting of these parameters leads to a error behavior of the PIP function.

The PIP display is controlled by the commands written into the register PIOPER. For the VPC_{main}, the PIP display is turned on or off by the commands DISSTART and DISSTOP. For the VPC_{pip} and VPC_{single}, 8 commands are available:

- WRFRCOL1, WRFRCOL2: to fill the frame of a inset picture with the color COLFR1 or COLFR2,
- WRBGD, WRBGDNF: to fill a inset picture with the background color COLBGD,
- WRPIC, WRPICNF, WRSTOP: to start and stop to write a inset picture with the active video,
- WRMAIN: to start write the main picture part outside the inset picture(s) with the active video (only for VPC_{single}).

While WRPIC, WRSTOP, WRFRCOL1, WRFRCOL2 and WRBGD control a display with a frame (see Fig. 5–2), WRPICNF and WRBGDNF control a display without a frame (see Fig. 5–3). The number of the inset picture addressed by the current command is given by bits NSPX and NSPY in the register PIOPER.

In the display window, the coordinate of the upper-left corner of the inset picture with NSPX=0 and NSPY=0 is defined by the registers LINOFFS and PIXOFFS. If

maximal 4x4 inset pictures are used, no new setting of these registers is needed. The default setting LINOFFS=0 and PIXOFFS=0 takes effect. If more than 4x4 inset pictures are involved in a PIP application, these inset pictures should be grouped, so that the inset pictures in each group can be addressed by bits NSPX and NSPY. For writing each group, the registers LINOFFS and PIXOFFS should be set correctly (see Fig.5–4).

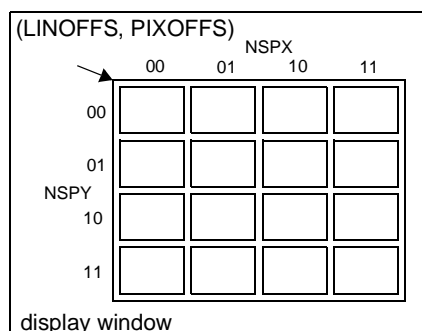
**Fig. 5–2:** 4x4 inset pictures with frame

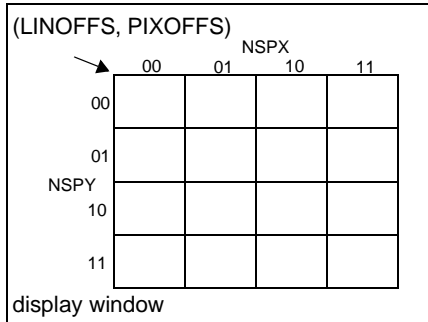

Fig. 5-3: 4x4 inset pictures without frame

5.2.3.2. Select a Strobe Effect in Expert Mode

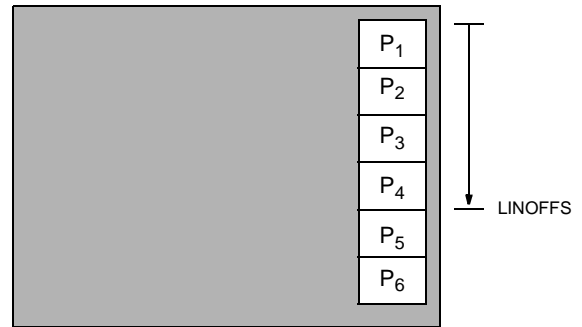

Fig. 5-4: Example of the expert mode

5.2.3. Examples

5.2.3.1. Select Predefined Mode 2

Scaler settings for VPC_{pip}:

SCINC1 = h'600
 FFLIM = h'168
 NEWLIN = h'194
 AVSTRT = h'86
 AVSTOP = h'356
 SC_PIP = h'11
 SC_BRI = h'110
 SC_CT = h'30
 SC_MODE = h'00 (for S411=0)

PIP controller settings to start PIP display:

For the VPC_{pip}:
 VPCMODE = h'01
 PIPMODE = h'02
 PIPOPER = h'c0 (write the background)
 wait until NEWCMD = 0
 PIPOPER = h'a0 (write the frame)
 wait until NEWCMD = 0
 PIPOPER = h'80 (start writing PIP)

After that the PIP position can be changed via HSTR and VSTR registers. e.g. HSTR = h'03

For the VPC_{main}:
 VPCMODE = h'05
 PIPMODE = h'02
 PIPOPER = h'80 (start display PIP)

PIP controller settings to stop PIP display:

For the VPC_{main}:
 PIPOPER = h'90 (stop display PIP)

Scaler settings for VPC_{pip}:

SCINC1 = h'480
 FFLIM = h'78
 NEWLIN = h'194
 AVSTRT = h'86
 AVSTOP = h'356
 SC_PIP = h'1f
 SC_BRI = h'310
 SC_CT = h'30
 SC_MODE = h'00 (for S411=0)

PIP controller settings to show a strobe effect:

For the VPC_{pip}:
 VPCMODE = h'01
 PIPMODE = h'0f
 VSTR = h'202
 HSTR = h'101
 NPIX = h'1c
 NLIN = h'2c
 NPFB = h'132

PIPOPER = h'c0 (write the background of P1)
 wait until NEWCMD = 0
 PIPOPER = h'a0 (write the frame of P1)
 wait until NEWCMD = 0
 PIPOPER = h'80 (start writing PIP of P1)
 wait until NEWCMD = 0

PIPOPER = h'c4 (write the background of P2)
 wait until NEWCMD = 0
 PIPOPER = h'a4 (write the frame of P2)
 wait until NEWCMD = 0
 PIPOPER = h'84 (start writing PIP of P2)
 wait until NEWCMD = 0

PIPOPER = h'c8 (write the background of P3)
 wait until NEWCMD = 0
 PIPOPER = h'a8 (write the frame of P3)
 wait until NEWCMD = 0
 PIPOPER = h'88 (start writing PIP of P3)

wait until NEWCMD = 0

PIPOPER = h'cc (write the background of P4)
wait until NEWCMD = 0
PIPOPER = h'ac (write the frame of P4)
wait until NEWCMD = 0
PIPOPER = h'8c (start writing PIP of P4)
wait until NEWCMD = 0

LINOFFS = h'2b8

PIPOPER = h'c0 (write the background of P5)
wait until NEWCMD = 0
PIPOPER = h'a0 (write the frame of P5)
wait until NEWCMD = 0
PIPOPER = h'80 (start writing PIP of P5)
wait until NEWCMD = 0

PIPOPER = h'c4 (write the background of P6)
wait until NEWCMD = 0
PIPOPER = h'a4 (write the frame of P6)
wait until NEWCMD = 0
PIPOPER = h'84 (start writing PIP of P6)

For the VPC_{main}:
VPCMODE = h'05
PIPMODE = h'0f
VSTR = h'201
HSTR = h'193
NPIX = h'1e
NLIN = h'116
NPFb = h'132
PIPOPER = h'80 (start display PIP)

PIP controller settings to stop PIP display:

For the VPC_{main}:
PIPOPER = h'90 (stop display PIP)

5.2.3.3. Select Predefined Mode 6 for Tuner Scanning

Scaler settings for VPC_{pip}:

SCINC1 = h'600
FFLIM = h'168
NEWLIN = h'194
AVSTRT = h'86
AVSTOP = h'356
SC_PIP = h'11
SC_BRI = h'110
SC_CT = h'30
SC_MODE = h'00 (for S411=0)

PIP controller settings for tuner scanning:

For the VPC_{pip}:
VPCMODE = h'01

PIPMODE = h'06

PIPOPER = h'c0 (write the background of P1)
wait until NEWCMD = 0
PIPOPER = h'a0 (write the frame of P1)
wait until NEWCMD = 0

PIPOPER = h'c1 (write the background of P2)
wait until NEWCMD = 0
PIPOPER = h'a1 (write the frame of P2)
wait until NEWCMD = 0

PIPOPER = h'c4 (write the background of P3)
wait until NEWCMD = 0
PIPOPER = h'a4 (write the frame of P3)
wait until NEWCMD = 0

PIPOPER = h'c5 (write the background of P4)
wait until NEWCMD = 0
PIPOPER = h'a5 (write the frame of P4)
wait until NEWCMD = 0

For the VPC_{main}:
VPCMODE = h'05
PIPMODE = h'46
PIPOPER = h'80 (start display multi PIP)

For the VPC_{pip}:
tune a channel
PIPOPER = h'80 (start writing PIP of P1)
wait until NEWCMD = 0
PIPOPER = h'90 (stop writing PIP of P1)
wait until NEWCMD = 0

tune an other channel
PIPOPER = h'81 (start writing PIP of P2)
wait until NEWCMD = 0
PIPOPER = h'91 (stop writing PIP of P2)
wait until NEWCMD = 0

tune an other channel
PIPOPER = h'84 (start writing PIP of P3)
wait until NEWCMD = 0
PIPOPER = h'94 (stop writing PIP of P3)
wait until NEWCMD = 0

tune an other channel
PIPOPER = h'85 (start writing PIP of P4)
wait until NEWCMD = 0
PIPOPER = h'95 (stop writing PIP of P4)
wait until NEWCMD = 0

The tuning and writing of the four inset pictures are repeated.

PIP controller settings to stop tuner scanning:

For the VPC_{main}:
PIPOPER = h'90 (stop display PIP)

6. Data Sheet History

1. Advance Information: "VPC 323xD, VPC 324xD Comb Filter Video Processor, Jan. 19, 1999, 6251-472-1AI. First release of the advance information.

Micronas GmbH
Hans-Bunte-Strasse 19
D-79108 Freiburg (Germany)
P.O. Box 840
D-79008 Freiburg (Germany)
Tel. +49-761-517-0
Fax +49-761-517-2174
E-mail: docservice@micronas.com
Internet: www.micronas.com

Printed in Germany
Order No. 6251-472-1AI

All information and data contained in this data sheet are without any commitment, are not to be considered as an offer for conclusion of a contract, nor shall they be construed as to create any liability. Any new issue of this data sheet invalidates previous issues. Product availability and delivery are exclusively subject to our respective order confirmation form; the same applies to orders based on development samples delivered. By this publication, Micronas GmbH does not assume responsibility for patent infringements or other rights of third parties which may result from its use.

Further, Micronas GmbH reserves the right to revise this publication and to make changes to its content, at any time, without obligation to notify any person or entity of such revisions or changes.

No part of this publication may be reproduced, photocopied, stored on a retrieval system, or transmitted without the express written consent of Micronas GmbH.