

High Frequency Chip Resistor Terminators

PFC HF Series

- Long life self-passivating TaNFilm® element
- Frequency performance characterized to 6GHz
- Available in 0402, 0603, 0805 and 1206 chip sizes
- Standard Sn/Pb and Pb-free terminations available

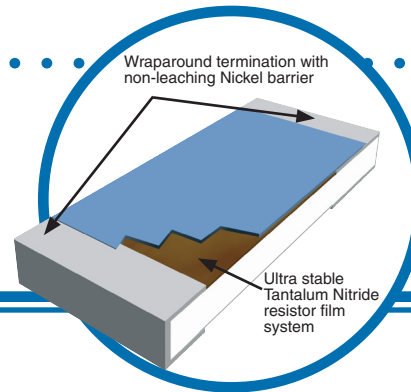

The PFC-HF series of high frequency chip terminators are available in standard chip resistor sizes. Available in 0402, 0603, 0805 and 1206 chip sizes, the PFC-HF is a drop-in replacement for poorer performing standard size chips.

With operation characterized to 6GHz, the PFC-HF series is suitable for RF and microwave transmission line termination as well as high speed digital line termination. Applications include SCSI bus termination, DDR memory termination, RF and microwave transmit and receive line terminations and general high speed transmission line termination.

Electrical Data

Model	Impedance	Power Rating @ 70C	Available Tolerances	Operating Temperature Range	Noise	Termination	Substrate
W0402HF	50Ω and 75Ω	50mW	±10%, ±5%, ±2%, ±1%	-55°C to ±125°C	<-25dB	60/40 Sn/Pb Plate or Matte Tin Finish	99.5% Alumina
W0603HF		100mW					
W0805HF		250mW					
W1206HF		333mW					

Environmental Data

Environmental Test MIL-PRF-55342	Maximum ΔR per Characteristic E	Performance	
		Typical	Maximum
Thermal Shock	±0.10%	±0.02%	±0.10%
Low Temperature Operation	±0.10%	±0.01%	±0.05%
Short Time Overload	±0.10%	±0.01%	±0.05%
High Temperature Exposure	±0.10%	±0.03%	±0.10%
Effects of Solder	±0.20%	±0.01%	±0.10%
Moisture Resistance	±0.20%	±0.03%	±0.10%
Life	±0.50%	±0.03%	±0.10%

General Note

IRC reserves the right to make changes in product specification without notice or liability. All information is subject to IRC's own data and is considered accurate at time of going to print.

High Frequency Chip Resistor Terminators

Frequency Performance Data

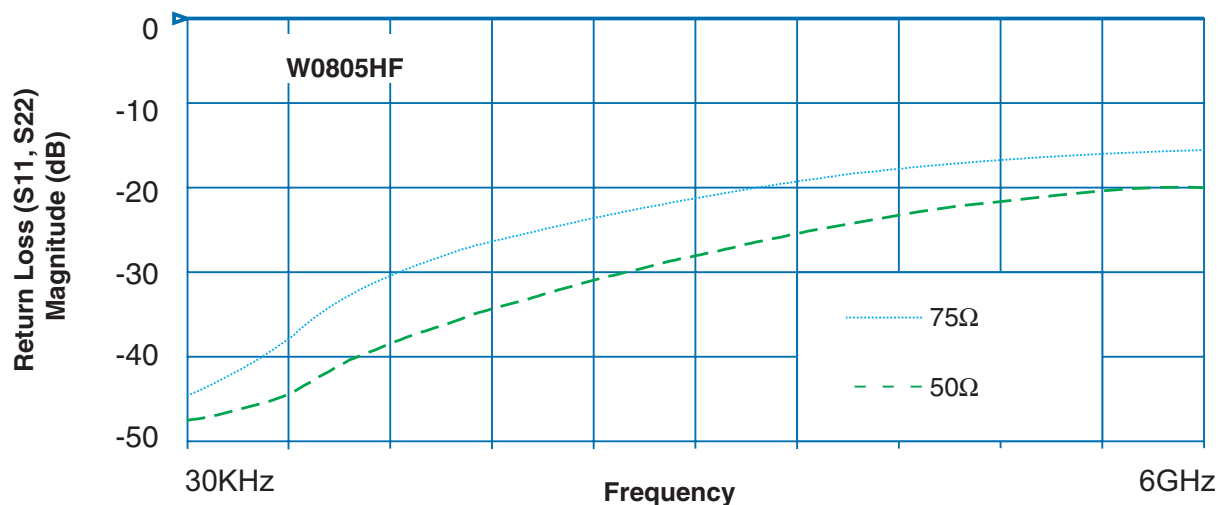
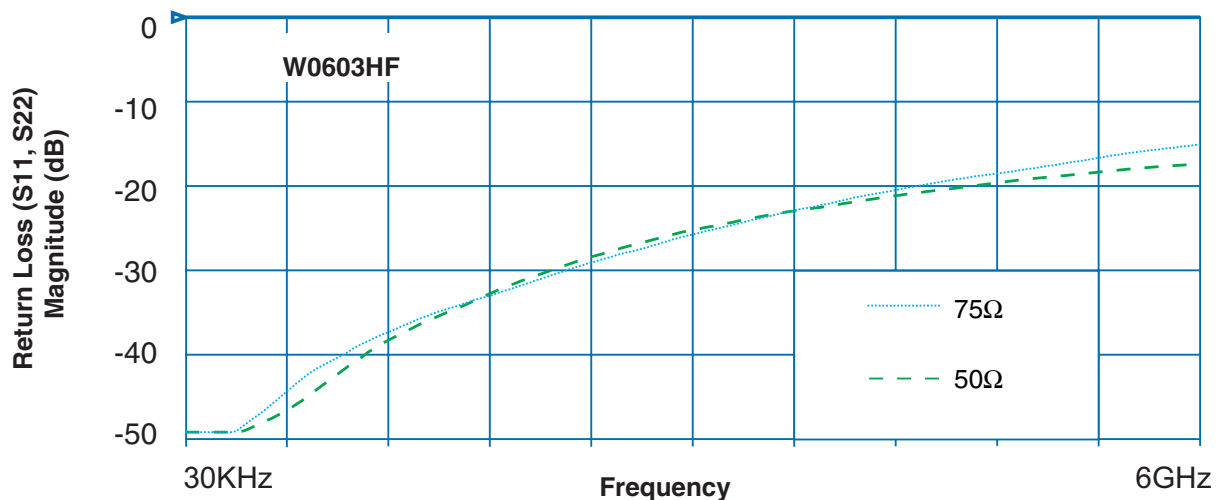
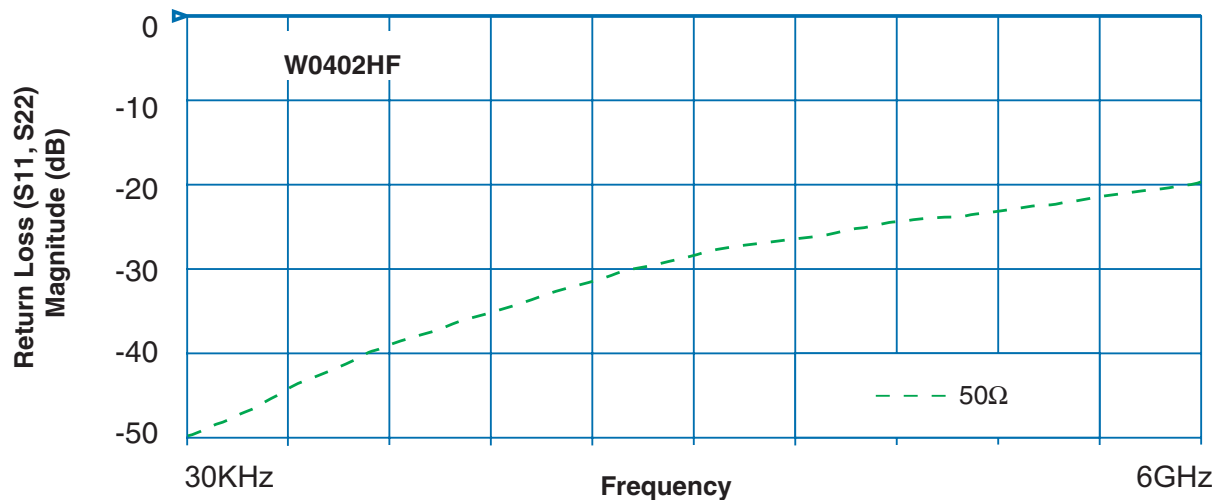

High Frequency Chip Resistor Terminators

Frequency Performance Data

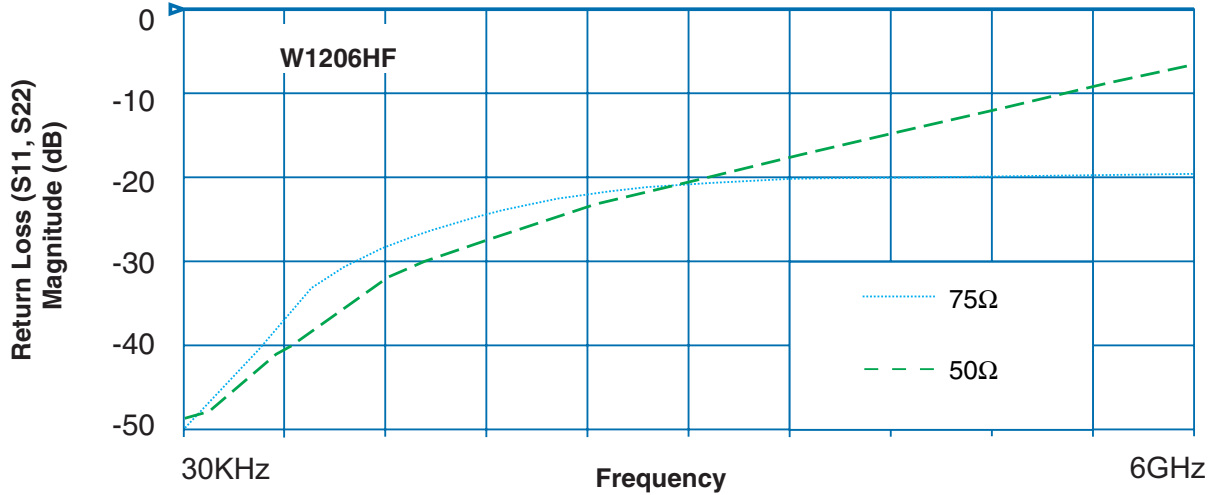

Modeling Data for 50Ω Terminator

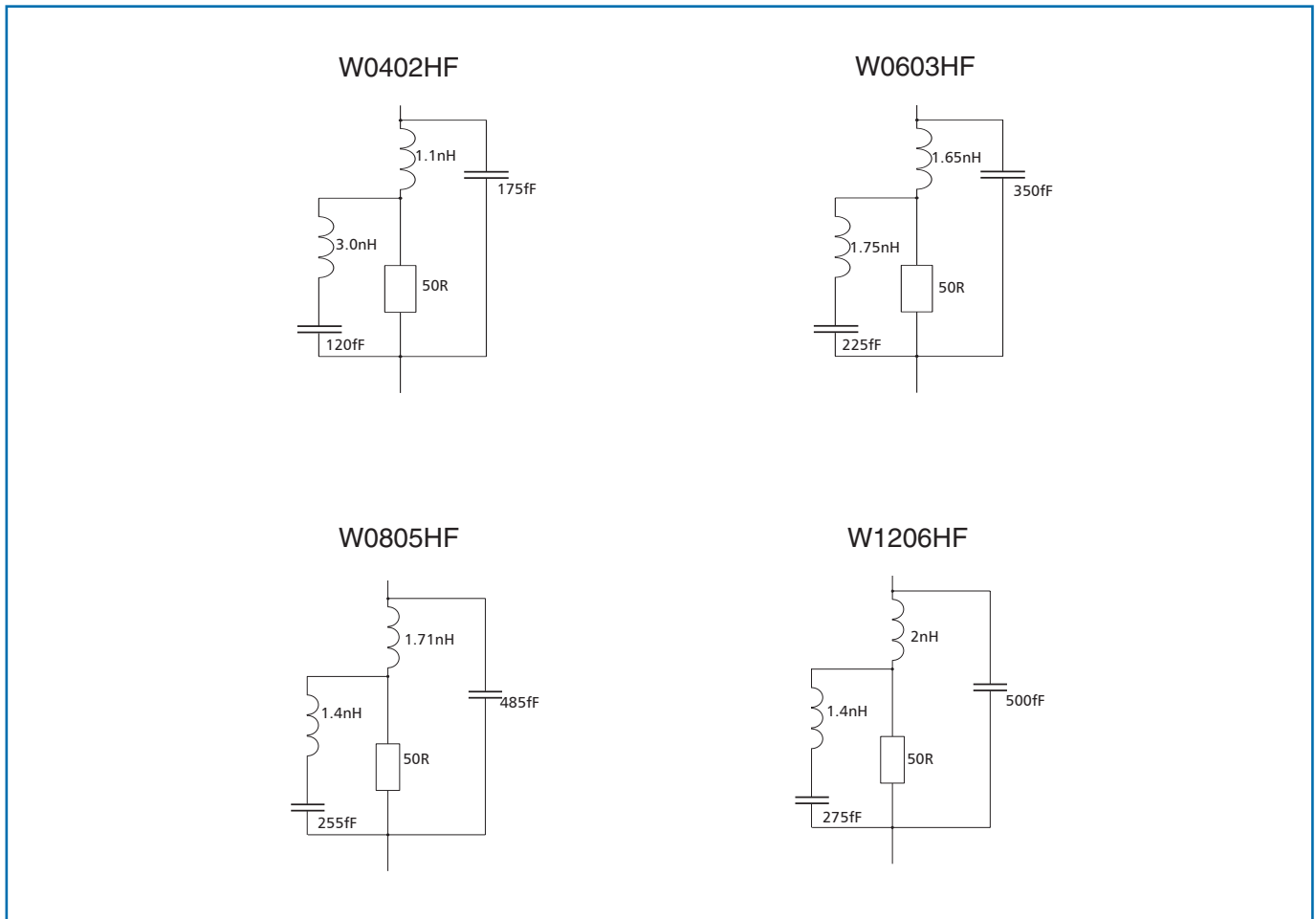

High Frequency Chip Resistor Terminators

Physical Data

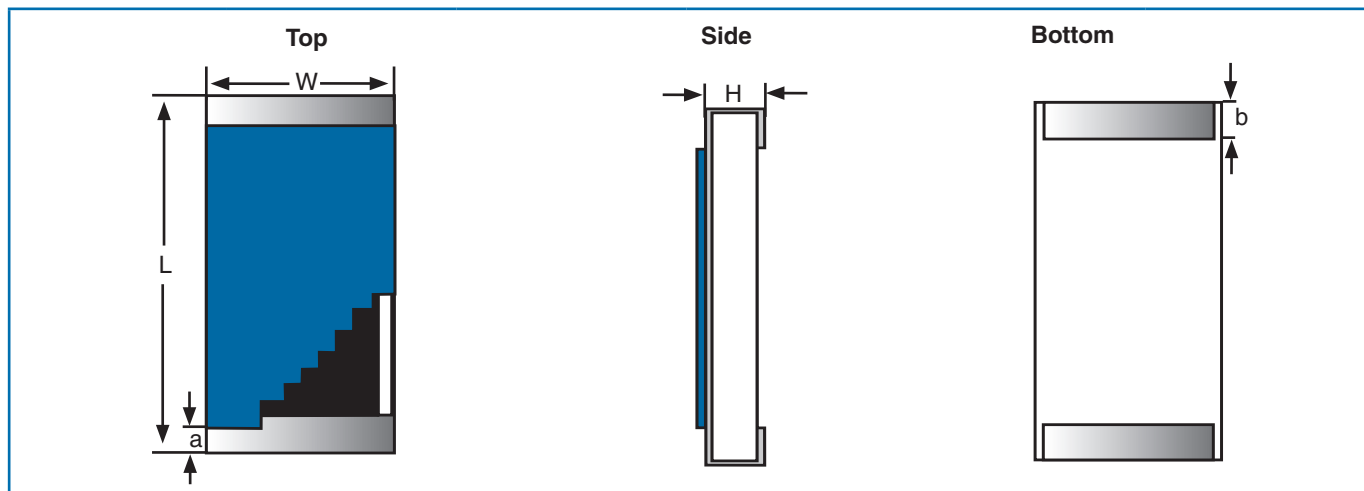

Dimensions (mm)

	L	W	H	a	b
W0402HF	0.040" ± 0.002	0.021" ± 0.002	0.012" ± 0.003	0.008" ± 0.002	0.010" ± 0.002
W0603HF	0.063" ± 0.004	0.031" ± 0.004	0.020" ± 0.004	0.012" ± 0.005	0.015" ± 0.005
W0805HF	0.081" ± 0.005	0.050" ± 0.005	0.020" ± 0.006	0.016" ± 0.008	0.016" ± 0.008
W1206HF	0.126" ± 0.006	0.063" ± 0.005	0.024" ± 0.004	0.025" ± 0.010	0.025" ± 0.010

Power Derating Curve

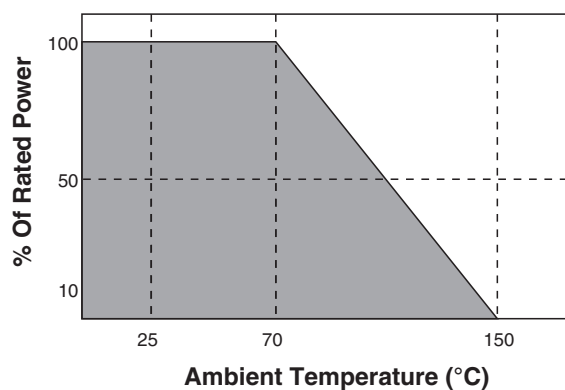

Ordering Data

Prefix **PFC** - **W0603** **HF** - **01** - **50R0** - **F**

Model
W0402; W0603; W0805; W1206

Termination
HF = 60/40 Sn/Pb plated solder
HFLF = 100% tin plated (Pb-free)

TCR Code
01 = ±100ppm/°C; 02 = ±50ppm/°C; 03 = ±25ppm/°C

Resistance Code
50R0 = 50Ω; 75R0 = 75Ω

Tolerance Code
K = ±10%; J = ±5%; G = ±2%; F = ±1%

For additional information or to discuss your specific requirements, please contact our Applications Team using the contact details below.