

Features

- Very Low DC Power Consumption: 100 μ W
- Low Insertion Loss: 0.5 dB
- High Isolation: 25 dB up to 2 GHz
- Very High Intercept Point: 45 dBm IP₃
- Nanosecond Switching Speed
- Lead-Free SOIC-8 Package
- 100% Matte Tin Plating over Copper
- Halogen-Free "Green" Mold Compound
- 260°C Reflow Compatible
- RoHS* Compliant Version of the SW-239

Description

M/A-COM's MASWSS0157 is a GaAs MMIC SPDT switch in a lead-free SOIC 8-lead surface mount plastic package. The MASWSS0157 is ideally suited for use where low power consumption is required.

Typical applications include transmit/receive switching, switch matrices and switched filter banks in systems such as radio and cellular equipment, PCM, GPS, fiber optic modules, and other battery powered radio equipment.

The MASWSS0157 is fabricated using a monolithic GaAs MMIC using a mature 1 micron process. The process features full chip passivation for increased performance and reliability.

Functional Schematic

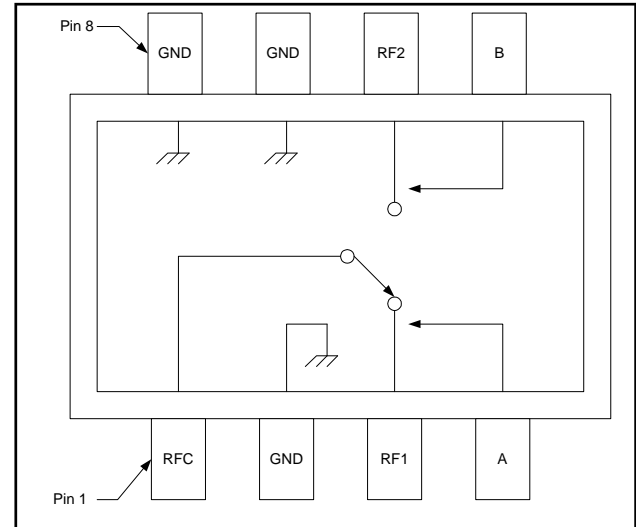

Pin Configuration

Pin No.	Function	Pin No.	Function
1	RF Common	5	Control B
2	Ground	6	RF Port 2
3	RF Port 1	7	Ground
4	Control A	8	Ground

Ordering Information ¹

Part Number	Package
MASWSS0157	Bulk Packaging
MASWSS0157TR	1000 piece reel
MASWSS0157TR-3000	3000 piece reel
MASWSS0157SMB	Sample Test Board

1. Reference Application Note M513 for reel size information.

Absolute Maximum Ratings ^{2,3}

Parameter	Absolute Maximum
Input Power 0.05 GHz 0.5 - 2.0 GHz	+27 dBm +34 dBm
Control Voltage	-8.5 V \leq V _c \leq +5 V
Operating Temperature	-40°C to +85°C
Storage Temperature	-65°C to +150°C

2. Exceeding any one or combination of these limits may cause permanent damage to this device.
3. M/A-COM does not recommend sustained operation near these survivability limits.

* Restrictions on Hazardous Substances, European Union Directive 2002/95/EC.

1

ADVANCED: Data Sheets contain information regarding a product M/A-COM Technology Solutions is considering for development. Performance is based on target specifications, simulated results, and/or prototype measurements. Commitment to develop is not guaranteed.
PRELIMINARY: Data Sheets contain information regarding a product M/A-COM Technology Solutions has under development. Performance is based on engineering tests. Specifications are typical. Mechanical outline has been fixed. Engineering samples and/or test data may be available. Commitment to produce in volume is not guaranteed.

- **North America** Tel: 800.366.2266 / Fax: 978.366.2266
 - **Europe** Tel: 44.1908.574.200 / Fax: 44.1908.574.300
 - **Asia/Pacific** Tel: 81.44.844.8296 / Fax: 81.44.844.8298
- Visit www.macomtech.com for additional data sheets and product information.

M/A-COM Technology Solutions Inc. and its affiliates reserve the right to make changes to the product(s) or information contained herein without notice.

Electrical Specifications: $T_A = 25^\circ\text{C}$, $V_c = 0\text{ V} / -5\text{ V}$, $Z_0 = 50\text{ Ohms}^4$

Parameter	Test Conditions	Units	Min.	Typ.	Max.
Insertion Loss	DC - 0.1 GHz	dB	—	0.4	—
	DC - 0.5 GHz	dB	—	0.4	—
	DC - 1.0 GHz	dB	—	0.5	0.8
	DC - 2.0 GHz	dB	—	0.6	—
Isolation	DC - 0.1 GHz	dB	—	56	—
	DC - 0.5 GHz	dB	—	43	—
	DC - 1.0 GHz	dB	30	33	—
	DC - 2.0 GHz	dB	—	24	—
VSWR	DC - 2.0 GHz	Ratio	—	1.4:1	—
Trise, Tfall	10% to 90% RF, 90% to 10% RF	nS	—	2	—
Ton, Toff	50% Control to 90% RF, 50% Control to 10% RF	nS	—	4	—
Transients	In-Band	mV	—	15	—
1 dB Compression Point	Input Power, 0.05 GHz	dBm	—	21	—
	Input Power, 0.5 - 2.0 GHz	dBm	—	27	—
2nd Order Intercept	Measured Relative to Input Power (for two-tone input power up to +6 dBm) 0.05 GHz	dBm	—	55	—
	0.5 - 2.0 GHz	dBm	—	68	—
3rd Order Intercept	Measured Relative to Input Power (for two-tone input power up to +6 dBm) 0.05 GHz	dBm	—	40	—
	0.5 - 2.0 GHz	dBm	—	45	—
Control Current	$ V_c = 5\text{ V}$	μA	—	20	25

4. For positive voltage control, external DC blocking capacitors are required on all RF ports.

Handling Procedures

Please observe the following precautions to avoid damage:

Static Sensitivity

Gallium Arsenide Integrated Circuits are sensitive to electrostatic discharge (ESD) and can be damaged by static electricity. Proper ESD control techniques should be used when handling these devices.

Truth Table ⁵

Control Inputs		Condition of Switch RF Common to Each RF Port	
A	B	RF1	RF2
1	0	On	Off
0	1	Off	On

5. 0 = 0 V to -0.2 V, 1 = -5 V to -8 V

Typical Performance Curves

Insertion Loss

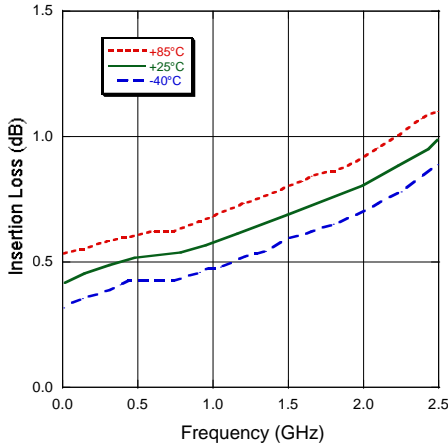

Isolation

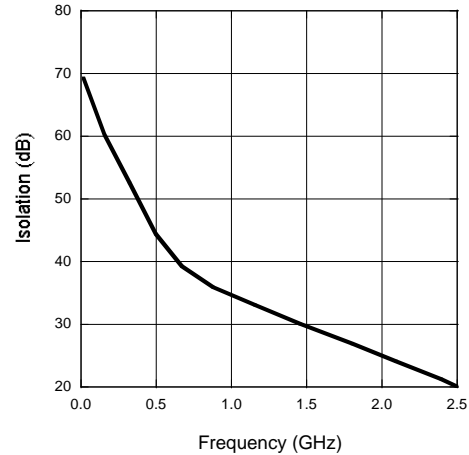

VSWR

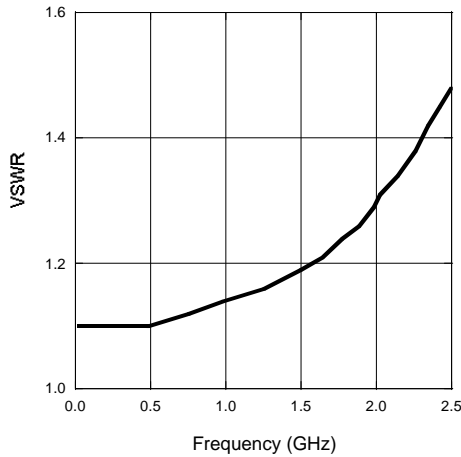

Electrical Schematic

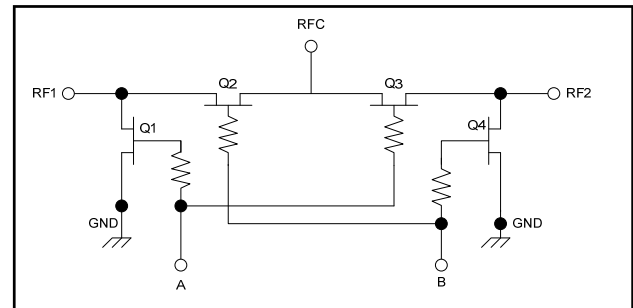

Lead-Free SOIC-8†

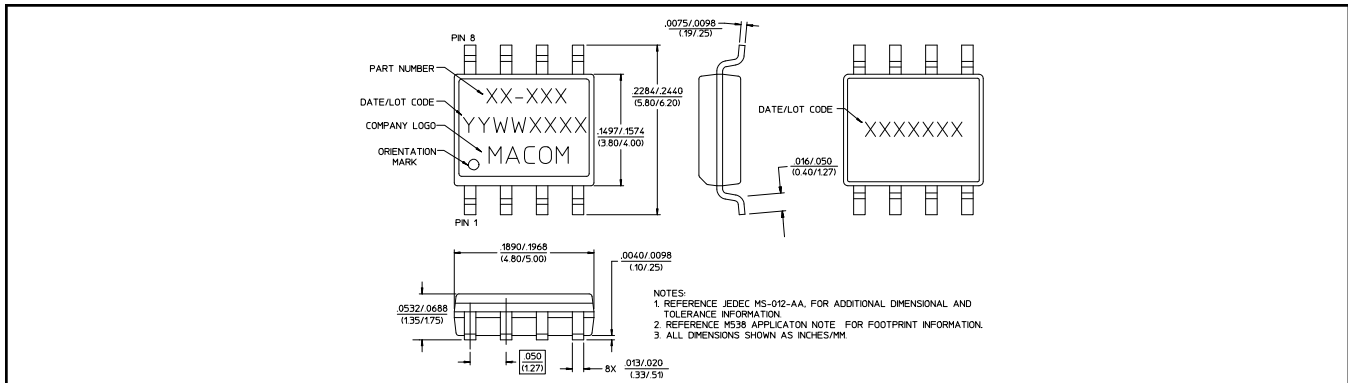

† Reference Application Note M538 for lead-free solder reflow recommendations.

ADVANCED: Data Sheets contain information regarding a product M/A-COM Technology Solutions is considering for development. Performance is based on target specifications, simulated results, and/or prototype measurements. Commitment to develop is not guaranteed.
PRELIMINARY: Data Sheets contain information regarding a product M/A-COM Technology Solutions has under development. Performance is based on engineering tests. Specifications are typical. Mechanical outline has been fixed. Engineering samples and/or test data may be available. Commitment to produce in volume is not guaranteed.

• **North America** Tel: 800.366.2266 / Fax: 978.366.2266
 • **Europe** Tel: 44.1908.574.200 / Fax: 44.1908.574.300
 • **Asia/Pacific** Tel: 81.44.844.8296 / Fax: 81.44.844.8298
 Visit www.macomtech.com for additional data sheets and product information.

M/A-COM Technology Solutions Inc. and its affiliates reserve the right to make changes to the product(s) or information contained herein without notice.