

**GaAs SPDT Switch
DC - 3.0 GHz**

**MASWSS0115
V5**

Features

- Low Insertion Loss: 0.3 dB @ 2.4 GHz
- Moderate Isolation: 22 dB @ 2.4 GHz
- Low Power Consumption: <5 μ A @ +2.3V
- Lead-Free SOT-363 Package
- 100% Matte Tin Plating over Copper
- Halogen-Free Mold Compound
- 260°C Reflow Compatible
- RoHS* Compliant Version of SW-485

Description

M/A-COM's MASWSS0115 is a GaAs PHEMT MMIC single pole, double throw (SPDT) switch in a low cost, lead-free SC-70 (SOT-363) surface mount plastic package. The MASWSS0115 is ideally suited for applications where very small size and low cost are required.

Typical applications are dual band systems which require switching between small signal components such as filter banks, single-band LNAs, converters, etc. This part can be used for low power, low loss requirements in all systems operating up to 3 GHz, including PCS, GSM, DCS, Blue Tooth, and other receive chain applications.

The MASWSS0115 is fabricated using a 0.5 micron gate length GaAs PHEMT process. The process features full passivation for performance and reliability.

Functional Schematic

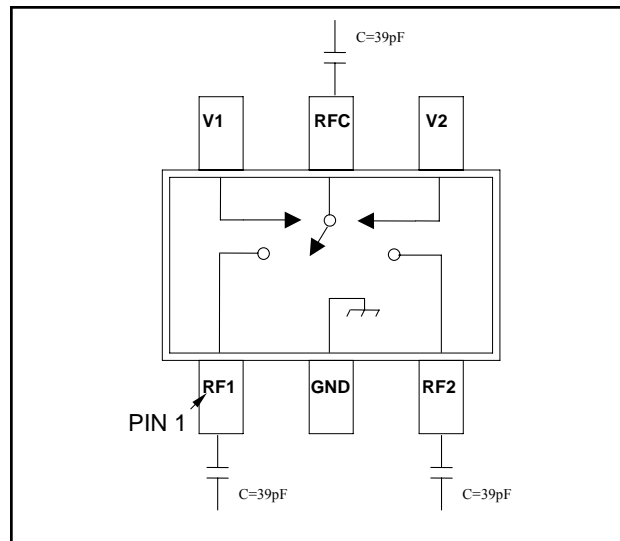

Pin Configuration

Pin No.	Function	Description
1	RF1	RF Port 1
2	GND	Ground
3	RF2	RF Port 2
4	V2	Control 2
5	RFC	RF Input
6	V1	Control 1

Ordering Information¹

Part Number	Package
MASWSS0115	Bulk packaging
MASWSS0115TR-3000	3000 piece reel
MASWSS0115SMB	Sample Board
MASWSS0115-DIE	Separated Die on Grip Ring ²

1. Reference Application Note M513 for reel size information.
2. Die quantity varies.

Absolute Maximum Ratings^{3,4}

Parameter	Absolute Maximum
Input Power (0.5 - 3.0 GHz) 2.5 V Control 5 V Control	+27 dBm +34 dBm
Voltage	\pm 8.5 volts
Operating Temperature	-40 °C to +85 °C
Storage Temperature	-65 °C to +150 °C

3. Exceeding any one or combination of these limits may cause permanent damage to this device.
4. M/A-COM does not recommend sustained operation near these survivability limits.

* Restrictions on Hazardous Substances, European Union Directive 2002/95/EC.

**GaAs SPDT Switch
DC - 3.0 GHz**

**MASWSS0115
V5**

Electrical Specifications: $T_A = 25^\circ\text{C}$, $V_c = 0\text{ V}/2.5\text{ V}$, $Z_0 = 50\text{ Ohms}$ ⁵

Parameter	Test Conditions	Units	Min.	Typ.	Max.
Insertion Loss ⁶	DC - 1 GHz	dB	—	0.25	0.40
	1 - 3 GHz	dB	—	0.30	0.55
Isolation	DC - 1 GHz	dB	20	24	—
	1 - 3 GHz	dB	—	22	—
Return Loss	0.05 - 3 GHz	dB	—	20	—
IP2	Two Tone, +5 dBm/tone, 5 MHz Spacing, >50 MHz	dBm	—	90	—
IP3	Two Tone, +5 dBm/tone, 5 MHz Spacing, >50 MHz	dBm	—	46	—
P1dB	$V_c = 0\text{ V}/2.5\text{ V}$	dBm	—	21	—
	$V_c = 0\text{ V}/3.0\text{ V}$	dBm	—	25	—
Trise, Tfall	10% to 90% RF, 90% to 10% RF	nS	—	35	—
Ton, Toff	50% control to 90% RF, 50% control to 10% RF	nS	—	40	—
Transients	In band	mV	—	10	—
Control Current	$V_c = 2.5\text{ V}$	μA	—	5	20

5. External DC blocking capacitors are required on all RF ports.

6. Insertion loss can be optimized by varying the DC blocking capacitor value, e.g. 1000 pF for 100 MHz - 1 GHz, 39 pF for 0.5 GHz - 3 GHz.

Truth Table ^{7,8}

Control V1	Control V2	RFC-RF1	RFC-RF2
0	1	On	Off
1	0	Off	On

7. Differential voltage, $V(\text{state } 1) - V(\text{state } 0)$, must be +2.3 V minimum.

8. 0 = 0 V \pm 0.2 V, 1 = +2.3 V to 5.0 V

Qualification

Qualified to M/A-COM specification REL-201, Process Flow -2.

Handling Procedures

The following precautions should be observed to avoid damage:

Static Sensitivity

Gallium Arsenide Integrated Circuits are sensitive to electrostatic discharge (ESD) and can be damaged by static electricity. Proper ESD control techniques should be used when handling these devices.

Lead-Free SC-70 (SOT-363)[†]

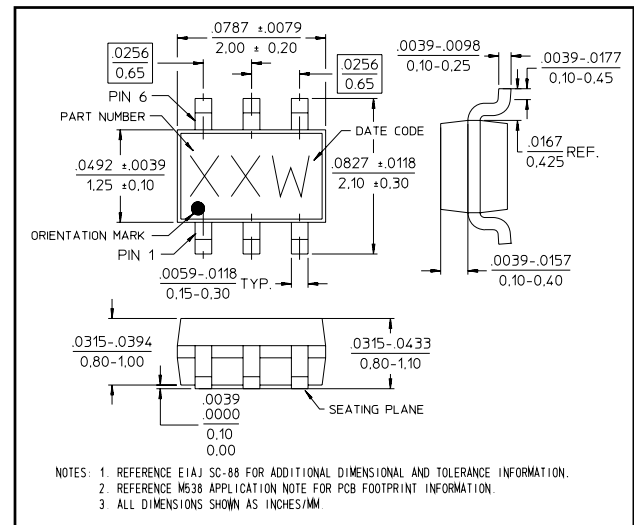

[†] Reference Application Note M538 for lead-free solder reflow recommendations.

Typical Performance Curves

Return Loss vs. Frequency

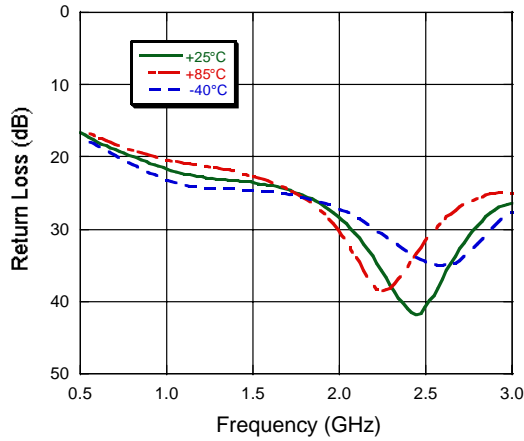

Isolation vs. Frequency

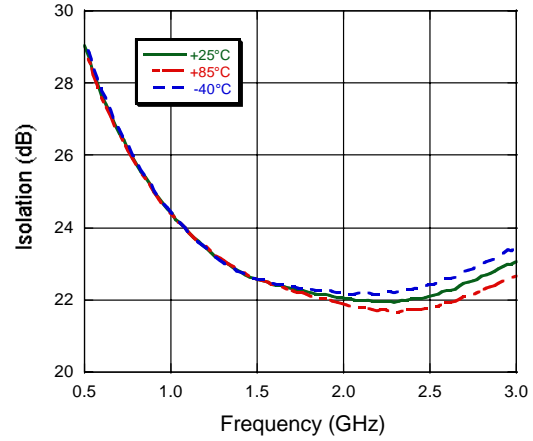

Insertion Loss vs. Frequency

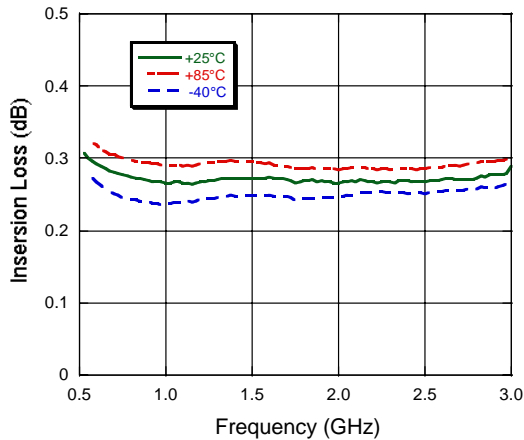

Die Bond Pad Layout

