

THREE TERMINAL NEGATIVE VOLTAGE REGULATORS
5V, 6V, 8V, 9V, 10V, 12V, 15V, 18V, 20V, 24V

FEATURES:

- Best Suited to a Power Supply for TTL and C²-MOS.
- Built-in Overcurrent Protective Circuit.
- Built-in Thermal Protective Circuit.
- Max. Output Current 150mA (T_j=25°C).
- Packaged in Power mini.

MAXIMUM RATINGS (Ta=25°C)

CHARACTERISTIC	SYMBOL	RATING	UNIT
Input Voltage	V _{IN}	-35	V
		-40	
Power Dissipation (Tc=25°C)	P _D	500	mW
Operating Junction Temperature	T _j	-30~150	°C
Operating Temperature	T _{opr}	-30~75	°C
Storage temperature	T _{stg}	-55~150	°C

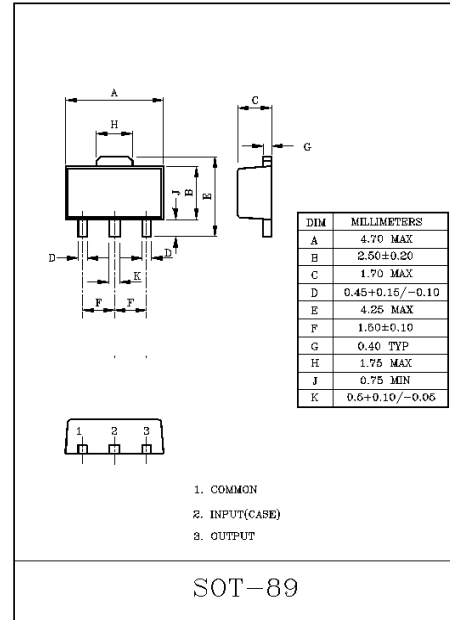

EQUIVALENT CIRCUIT

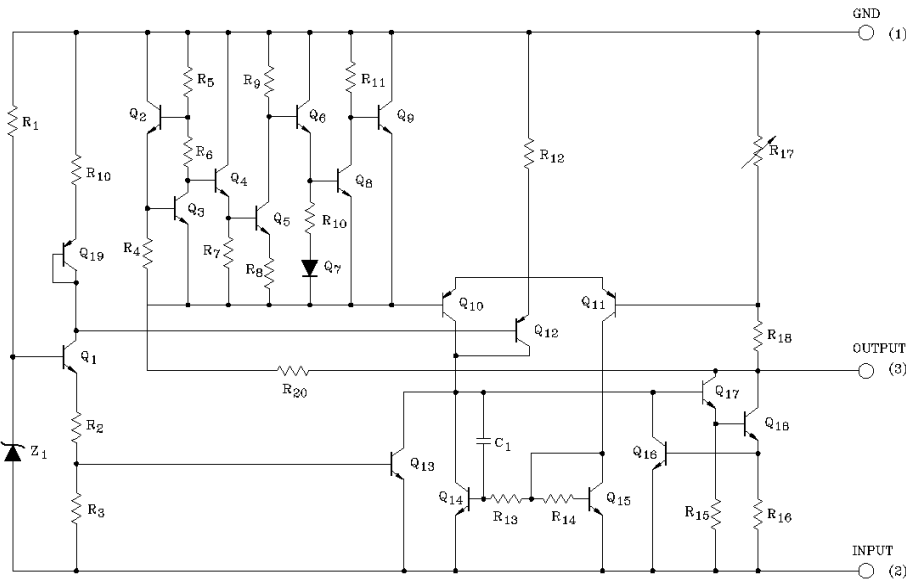

Marking

Type No.	Marking	Type No.	Marking	Type No.	Marking
KIA79L05F	9A	KIA89L10F	9E	KIA79L20F	9I
KIA79L06F	9B	KIA79L12F	9F	KIA79L24F	9J
KIA79L08F	9C	KIA79L15F	9G		
KIA79L09F	9D	KIA79L18F	9H		

KIA79L05F ~ KIA79L24F

ELECTRICAL CHARACTERISTICS

KIA79L05F

(Unless otherwise specified, $V_{IN}=-10V$, $I_{OUT}=40mA$, $C_{IN}=0.33\mu F$, $C_{OUT}=0.1\mu F$, $0^{\circ}C \leq T_j \leq 125^{\circ}C$)

CHARACTERISTIC	SYMBOL	TEST CIRCUIT	TEST CONDITION	MIN.	TYP.	MAX.	UNIT	
Output Voltage	V_{OUT}	1	$T_j=25^{\circ}C$	-5.2	-5.0	-4.8	V	
Input Regulation	Reg line	1	$T_j=25^{\circ}C$	$-20V \leq V_{IN} \leq -7.0V$	-	55	150	mV
				$-20V \leq V_{IN} \leq -8.0V$	-	45	100	
Load Regulation	Reg load	1	$T_j=25^{\circ}C$	$1.0mA \leq I_{OUT} \leq 100mA$	-	11	60	mV
				$1.0mA \leq I_{OUT} \leq 40mA$	-	5.0	30	
Output Voltage	V_{OUT}	1	$-20V \leq V_{IN} \leq -7.0V$ $1.0mA \leq I_{OUT} \leq 40mA$	-5.25	-	-4.75	V	
			$V_{IN}=-10V$, $1.0mA \leq I_{OUT} \leq 70mA$	-5.25	-	-4.75		
Quiescent Current	I_B	1	$T_j=25^{\circ}C$	-	3.1	6.0	mA	
			$T_j=125^{\circ}C$	-	-	5.5		
Quiescent Current Change	ΔI_{BI}	1	$-20V \leq V_{IN} \leq -8.0V$	-	-	1.5	mA	
	ΔI_{BO}		$1.0mA \leq I_{OUT} \leq 40mA$	-	-	0.1		
Output Noise Voltage	V_{NO}	3	$T_a=25^{\circ}C$, $10Hz \leq f \leq 100kHz$	-	40	-	μV_{rms}	
Long Term Stability	$\Delta V_{OUT}/\Delta t$	1		-	12	-	mV/ 1.0kHrs	
Ripple Rejection Ratio	RR	2	$-18V \leq V_{IN} \leq -8.0V$, $T_j=25^{\circ}C$, $f=120Hz$	41	49	-	dB	
Dropout Voltage	$ V_{IN} - V_{OUT} $	1	$T_j=25^{\circ}C$, $I_{OUT}=40mA$	-	1.7	-	V	
Average Temperature Coefficient of Output Voltage	TC_{VO}	1	$I_{OUT}=5mA$	-	-0.6	-	mV/ $^{\circ}C$	

KIA79L05F ~ KIA79L24F

ELECTRICAL CHARACTERISTICS

KIA79L06F

(Unless otherwise specified, $V_{IN}=-11V$, $I_{OUT}=40mA$, $C_{IN}=0.33\mu F$, $C_{OUT}=0.1\mu F$, $0^{\circ}C \leq T_j \leq 125^{\circ}C$)

CHARACTERISTIC	SYMBOL	TEST CIRCUIT	TEST CONDITION	MIN.	TYP.	MAX.	UNIT	
Output Voltage	V_{OUT}	1	$T_j=25^{\circ}C$	-6.24	-6.0	-5.76	V	
Input Regulation	Reg line	1	$T_j=25^{\circ}C$	$-21V \leq V_{IN} \leq -8.1V$	-	50	150	mV
				$-21V \leq V_{IN} \leq -9.0V$	-	45	110	
Load Regulation	Reg load	1	$T_j=25^{\circ}C$	$1.0mA \leq I_{OUT} \leq 100mA$	-	12	70	mV
				$1.0mA \leq I_{OUT} \leq 40mA$	-	5.5	35	
Output Voltage	V_{OUT}	1	$-21V \leq V_{IN} \leq -8.1V$ $1.0mA \leq I_{OUT} \leq 40mA$	-6.3	-	-5.7	V	
			$V_{IN}=-11V$, $1.0mA \leq I_{OUT} \leq 70mA$	-6.3	-	-5.7		
Quiescent Current	I_B	1	$T_j=25^{\circ}C$	-	3.1	6.0	mA	
			$T_j=125^{\circ}C$	-	-	5.5		
Quiescent Current Change	ΔI_{BI}	1	$-20V \leq V_{IN} \leq -9.0V$	-	-	1.5	mA	
	ΔI_{BO}		$1.0mA \leq I_{OUT} \leq 40mA$	-	-	0.1		
Output Noise Voltage	V_{NO}	3	$T_a=25^{\circ}C$, $10Hz \leq f \leq 100kHz$	-	40	-	μV_{rms}	
Long Term Stability	$\Delta V_{OUT}/\Delta t$	1		-	14	-	mV/ 1.0kHrs	
Ripple Rejection Ratio	RR	2	$-19V \leq V_{IN} \leq -9.0V$, $T_j=25^{\circ}C$, $f=120Hz$	39	47	-	dB	
Dropout Voltage	$ V_{IN}-V_{OUT} $	1	$T_j=25^{\circ}C$, $I_{OUT}=40mA$	-	1.7	-	V	
Average Temperature Coefficient of Output Voltage	TC_{VO}	1	$I_{OUT}=5mA$	-	-0.7	-	mV/ $^{\circ}C$	

KIA79L05F ~ KIA79L24F

ELECTRICAL CHARACTERISTICS

KIA79L08F

(Unless otherwise specified, $V_{IN}=-14V$, $I_{OUT}=40mA$, $C_{IN}=0.33\mu F$, $C_{OUT}=0.1\mu F$, $0^{\circ}C \leq T_j \leq 125^{\circ}C$)

CHARACTERISTIC	SYMBOL	TEST CIRCUIT	TEST CONDITION	MIN.	TYP.	MAX.	UNIT	
Output Voltage	V_{OUT}	1	$T_j=25^{\circ}C$	-8.3	-8.0	-7.7	V	
Input Regulation	Reg line	1	$T_j=25^{\circ}C$	$-23V \leq V_{IN} \leq -10.5V$	-	20	175	mV
				$-23V \leq V_{IN} \leq -11V$	-	12	125	
Load Regulation	Reg load	1	$T_j=25^{\circ}C$	$1.0mA \leq I_{OUT} \leq 100mA$	-	15	80	mV
				$1.0mA \leq I_{OUT} \leq 40mA$	-	7.0	40	
Output Voltage	V_{OUT}	1	$T_j=25^{\circ}C$	$-23V \leq V_{IN} \leq -10.5V$ $1.0mA \leq I_{OUT} \leq 40mA$	-8.4	-	-7.6	V
				$V_{IN}=-14V$, $1.0mA \leq I_{OUT} \leq 70mA$	-8.4	-	-7.6	
Quiescent Current	I_B	1	$T_j=25^{\circ}C$	-	3.1	6.5	mA	
			$T_j=125^{\circ}C$	-	-	6.0		
Quiescent Current Change	ΔI_{BI}	1	$T_j=25^{\circ}C$	$-23V \leq V_{IN} \leq -11V$	-	-	1.5	mA
	ΔI_{BO}			$1.0mA \leq I_{OUT} \leq 40mA$	-	-	0.1	
Output Noise Voltage	V_{NO}	3	$T_a=25^{\circ}C$, $10Hz \leq f \leq 100kHz$	-	60	-	μV_{rms}	
Long Term Stability	$\Delta V_{OUT}/\Delta t$	1		-	20	-	mV/ 1.0kHrs	
Ripple Rejection Ratio	RR	2	$-23V \leq V_{IN} \leq -12V$, $T_j=25^{\circ}C$, $f=120Hz$	37	45	-	dB	
Dropout Voltage	$ V_{IN}-V_{OUT} $	1	$T_j=25^{\circ}C$, $I_{OUT}=40mA$	-	1.7	-	V	
Average Temperature Coefficient of Output Voltage	TC_{VO}	1	$I_{OUT}=5mA$	-	-0.8	-	mV/ $^{\circ}C$	

KIA79L05F ~ KIA79L24F

ELECTRICAL CHARACTERISTICS

KIA79L09F

(Unless otherwise specified, $V_{IN} = -15V$, $I_{OUT} = 40mA$, $C_{IN} = 0.33\mu F$, $C_{OUT} = 0.1\mu F$, $0^{\circ}C \leq T_j \leq 125^{\circ}C$)

CHARACTERISTIC	SYMBOL	TEST CIRCUIT	TEST CONDITION	MIN.	TYP.	MAX.	UNIT	
Output Voltage	V_{OUT}	1	$T_j = 25^{\circ}C$	-9.36	-9.0	-8.64	V	
Input Regulation	Reg line	1	$T_j = 25^{\circ}C$	-24V \leq V_{IN} \leq -11.4V	-	80	200	mV
				-24V \leq V_{IN} \leq -12V	-	20	160	
Load Regulation	Reg load	1	$T_j = 25^{\circ}C$	$1.0mA \leq I_{OUT} \leq 100mA$	-	17	90	mV
				$1.0mA \leq I_{OUT} \leq 40mA$	-	8.0	45	
Output Voltage	V_{OUT}	1		-24V \leq V_{IN} \leq -11.4V $1.0mA \leq I_{OUT} \leq 40mA$	-9.45	-	-8.55	V
				$V_{IN} = -15V$, $1.0mA \leq I_{OUT} \leq 70mA$	-9.45	-	-8.55	
Quiescent Current	I_B	1	$T_j = 25^{\circ}C$		-	3.2	6.5	mA
			$T_j = 125^{\circ}C$		-	-	6.0	
Quiescent Current Change	ΔI_{BI}	1		-24V \leq V_{IN} \leq -12V	-	-	1.5	mA
	ΔI_{BO}			$1.0mA \leq I_{OUT} \leq 40mA$	-	-	0.1	
Output Noise Voltage	V_{NO}	3	$T_a = 25^{\circ}C$, $10Hz \leq f \leq 100kHz$	-	65	-	μV_{rms}	
Long Term Stability	$\Delta V_{OUT}/\Delta t$	1		-	21	-	mV/ 1.0kHrs	
Ripple Rejection Ratio	RR	2	-24V \leq V_{IN} \leq -12V, $T_j = 25^{\circ}C$, $f = 120Hz$	36	44	-	dB	
Dropout Voltage	$ V_{IN} - V_{OUT} $	1	$T_j = 25^{\circ}C$, $I_{OUT} = 40mA$	-	1.7	-	V	
Average Temperature Coefficient of Output Voltage	TC_{VO}	1	$I_{OUT} = 5mA$	-	-0.85	-	mV/ $^{\circ}C$	

KIA79L05F ~ KIA79L24F

ELECTRICAL CHARACTERISTICS

KIA79L10F

(Unless otherwise specified, $V_{IN}=-16V$, $I_{OUT}=40mA$, $C_{IN}=0.33\mu F$, $C_{OUT}=0.1\mu F$, $0^{\circ}C \leq T_j \leq 125^{\circ}C$)

CHARACTERISTIC	SYMBOL	TEST CIRCUIT	TEST CONDITION	MIN.	TYP.	MAX.	UNIT	
Output Voltage	V_{OUT}	1	$T_j=25^{\circ}C$	-10.4	-10.0	-9.6	V	
Input Regulation	Reg line	1	$T_j=25^{\circ}C$	-25V \leq V_{IN} \leq -12.5V	-	80	230	mV
				-25V \leq V_{IN} \leq -13V	-	30	170	
Load Regulation	Reg load	1	$T_j=25^{\circ}C$	$1.0mA \leq I_{OUT} \leq 100mA$	-	18	90	mV
				$1.0mA \leq I_{OUT} \leq 40mA$	-	8.5	45	
Output Voltage	V_{OUT}	1		-25V \leq V_{IN} \leq -12.5V $1.0mA \leq I_{OUT} \leq 40mA$	-10.5	-	-9.5	V
				$V_{IN}=-16V$, $1.0mA \leq I_{OUT} \leq 70mA$	-10.5	-	-9.5	
Quiescent Current	I_B	1	$T_j=25^{\circ}C$		-	3.2	6.5	mA
			$T_j=125^{\circ}C$		-	-	6.0	
Quiescent Current Change	ΔI_{BI}	1		-25V \leq V_{IN} \leq -13V	-	-	1.5	mA
	ΔI_{BO}			$1.0mA \leq I_{OUT} \leq 40mA$	-	-	0.1	
Output Noise Voltage	V_{NO}	3	$T_a=25^{\circ}C$, $10Hz \leq f \leq 100kHz$	-	70	-	μV_{rms}	
Long Term Stability	$\Delta V_{OUT}/\Delta t$	1		-	22	-	$\frac{mV}{1.0kHrs}$	
Ripple Rejection Ratio	RR	2	-24V \leq V_{IN} \leq -13V, $T_j=25^{\circ}C$, $f=120Hz$	36	43	-	dB	
Dropout Voltage	$ V_{IN}-V_{OUT} $	1	$T_j=25^{\circ}C$, $I_{OUT}=40mA$	-	1.7	-	V	
Average Temperature Coefficient of Output Voltage	TC_{VO}	1	$I_{OUT}=5mA$	-	-0.9	-	$mV/^{\circ}C$	

KIA79L05F ~ KIA79L24F

ELECTRICAL CHARACTERISTICS

KIA79L12F

(Unless otherwise specified, $V_{IN}=-19V$, $I_{OUT}=40mA$, $C_{IN}=0.33\mu F$, $C_{OUT}=0.1\mu F$, $0^{\circ}C \leq T_j \leq 125^{\circ}C$)

CHARACTERISTIC	SYMBOL	TEST CIRCUIT	TEST CONDITION	MIN.	TYP.	MAX.	UNIT	
Output Voltage	V_{OUT}	1	$T_j=25^{\circ}C$	-12.5	-12.0	-11.5	V	
Input Regulation	Reg line	1	$T_j=25^{\circ}C$	$-27V \leq V_{IN} \leq -14.5V$	-	120	250	mV
				$-27V \leq V_{IN} \leq -16V$	-	100	200	
Load Regulation	Reg load	1	$T_j=25^{\circ}C$	$1.0mA \leq I_{OUT} \leq 100mA$	-	20	100	mV
				$1.0mA \leq I_{OUT} \leq 40mA$	-	10	50	
Output Voltage	V_{OUT}	1	$T_j=25^{\circ}C$	$-27V \leq V_{IN} \leq -14.5V$ $1.0mA \leq I_{OUT} \leq 40mA$	-12.6	-	-11.4	V
				$V_{IN}=-19V$, $1.0mA \leq I_{OUT} \leq 70mA$	-12.6	-	-11.4	
Quiescent Current	I_B	1	$T_j=25^{\circ}C$		-	3.2	6.5	mA
				$T_j=125^{\circ}C$	-	-	6.0	
Quiescent Current Change	ΔI_{BI}	1	$T_j=25^{\circ}C$	$-27V \leq V_{IN} \leq -16V$	-	-	1.5	mA
	ΔI_{BO}			$1.0mA \leq I_{OUT} \leq 40mA$	-	-	0.1	
Output Noise Voltage	V_{NO}	3	$T_a=25^{\circ}C$, $10Hz \leq f \leq 100kHz$	-	80	-	μV_{rms}	
Long Term Stability	$\Delta V_{OUT}/\Delta t$	1		-	24	-	mV/ 1.0kHrs	
Ripple Rejection Ratio	RR	2	$-25V \leq V_{IN} \leq -15V$, $T_j=25^{\circ}C$, $f=120Hz$	37	42	-	dB	
Dropout Voltage	$ V_{IN} - V_{OUT} $	1	$T_j=25^{\circ}C$, $I_{OUT}=40mA$	-	1.7	-	V	
Average Temperature Coefficient of Output Voltage	TC_{VO}	1	$I_{OUT}=5mA$	-	-1.0	-	mV/ $^{\circ}C$	

KIA79L05F ~ KIA79L24F

ELECTRICAL CHARACTERISTICS

KIA79L15F

(Unless otherwise specified, $V_{IN} = -23V$, $I_{OUT} = 40mA$, $C_{IN} = 0.33\mu F$, $C_{OUT} = 0.1\mu F$, $0^{\circ}C \leq T_j \leq 125^{\circ}C$)

CHARACTERISTIC	SYMBOL	TEST CIRCUIT	TEST CONDITION	MIN.	TYP.	MAX.	UNIT	
Output Voltage	V_{OUT}	1	$T_j = 25^{\circ}C$	-15.6	-15.0	-14.4	V	
Input Regulation	Reg line	1	$T_j = 25^{\circ}C$	-30V \leq V_{IN} \leq -17.5V	-	130	300	mV
				-30V \leq V_{IN} \leq -20V	-	110	250	
Load Regulation	Reg load	1	$T_j = 25^{\circ}C$	$1.0mA \leq I_{OUT} \leq 100mA$	-	25	150	mV
				$1.0mA \leq I_{OUT} \leq 40mA$	-	12	75	
Output Voltage	V_{OUT}	1		-30V \leq V_{IN} \leq -17.5V $1.0mA \leq I_{OUT} \leq 40mA$	-15.75	-	-14.25	V
				$V_{IN} = -23V$, $1.0mA \leq I_{OUT} \leq 70mA$	-15.75	-	-14.25	
Quiescent Current	I_B	1	$T_j = 25^{\circ}C$		-	3.3	6.5	mA
			$T_j = 125^{\circ}C$		-	-	6.0	
Quiescent Current Change	ΔI_{BI}	1		-30V \leq V_{IN} \leq -20V	-	-	1.5	mA
	ΔI_{BO}			$1.0mA \leq I_{OUT} \leq 40mA$	-	-	0.1	
Output Noise Voltage	V_{NO}	3	$T_a = 25^{\circ}C$, $10Hz \leq f \leq 100kHz$	-	90	-	μV_{rms}	
Long Term Stability	$\Delta V_{OUT}/\Delta t$	1		-	30	-	mV/ 1.0kHrs	
Ripple Rejection Ratio	RR	2	-28.5V \leq V_{IN} \leq -18.5V, $T_j = 25^{\circ}C$, $f = 120Hz$	34	39	-	dB	
Dropout Voltage	$ V_{IN} - V_{OUT} $	1	$T_j = 25^{\circ}C$, $I_{OUT} = 40mA$	-	1.7	-	V	
Average Temperature Coefficient of Output Voltage	TC_{VO}	1	$I_{OUT} = 5mA$	-	-1.3	-	mV/ $^{\circ}C$	

KIA79L05F ~ KIA79L24F

ELECTRICAL CHARACTERISTICS

KIA79L18F

(Unless otherwise specified, $V_{IN}=-27V$, $I_{OUT}=40mA$, $C_{IN}=0.33\mu F$, $C_{OUT}=0.1\mu F$, $0^{\circ}C \leq T_j \leq 125^{\circ}C$)

CHARACTERISTIC	SYMBOL	TEST CIRCUIT	TEST CONDITION	MIN.	TYP.	MAX.	UNIT	
Output Voltage	V_{OUT}	1	$T_j=25^{\circ}C$	-18.7	-18.0	-17.3	V	
Input Regulation	Reg line	1	$T_j=25^{\circ}C$	$-33V \leq V_{IN} \leq -20.7V$	-	32	325	mV
				$-33V \leq V_{IN} \leq -21V$	-	27	275	
Load Regulation	Reg load	1	$T_j=25^{\circ}C$	$1.0mA \leq I_{OUT} \leq 100mA$	-	30	170	mV
				$1.0mA \leq I_{OUT} \leq 40mA$	-	15	75	
Output Voltage	V_{OUT}	1	$T_j=25^{\circ}C$	$-33V \leq V_{IN} \leq -20.9V$ $1.0mA \leq I_{OUT} \leq 40mA$	-18.9	-	-17.1	V
				$V_{IN}=-27V$, $1.0mA \leq I_{OUT} \leq 70mA$	-18.9	-	-17.1	
Quiescent Current	I_B	1	$T_j=25^{\circ}C$	-	3.3	6.5	mA	
			$T_j=125^{\circ}C$	-	-	6.0		
Quiescent Current Change	ΔI_{BI}	1	$T_j=25^{\circ}C$	$-33V \leq V_{IN} \leq -21V$	-	-	1.5	mA
	ΔI_{BO}			$1.0mA \leq I_{OUT} \leq 40mA$	-	-	0.1	
Output Noise Voltage	V_{NO}	3	$T_a=25^{\circ}C$, $10Hz \leq f \leq 100kHz$	-	150	-	μV_{rms}	
Long Term Stability	$\Delta V_{OUT}/\Delta t$	1		-	45	-	mV/ 1.0kHrs	
Ripple Rejection Ratio	RR	2	$-33V \leq V_{IN} \leq -23V$, $T_j=25^{\circ}C$, $f=120Hz$	33	48	-	dB	
Dropout Voltage	$ V_{IN} - V_{OUT} $	1	$T_j=25^{\circ}C$, $I_{OUT}=40mA$	-	1.7	-	V	
Average Temperature Coefficient of Output Voltage	TC_{VO}	1	$I_{OUT}=5mA$	-	-1.5	-	mV/ $^{\circ}C$	

KIA79L05F ~ KIA79L24F

ELECTRICAL CHARACTERISTICS

KIA79L20F

(Unless otherwise specified, $V_{IN}=-29V$, $I_{OUT}=40mA$, $C_{IN}=0.33\mu F$, $C_{OUT}=0.1\mu F$, $0^{\circ}C \leq T_j \leq 125^{\circ}C$)

CHARACTERISTIC	SYMBOL	TEST CIRCUIT	TEST CONDITION	MIN.	TYP.	MAX.	UNIT	
Output Voltage	V_{OUT}	1	$T_j=25^{\circ}C$	-20.8	-20.0	-19.2	V	
Input Regulation	Reg line	1	$T_j=25^{\circ}C$	$-35V \leq V_{IN} \leq -23.5V$	-	33	330	mV
				$-35V \leq V_{IN} \leq -24V$	-	28	285	
Load Regulation	Reg load	1	$T_j=25^{\circ}C$	$1.0mA \leq I_{OUT} \leq 100mA$	-	33	180	mV
				$1.0mA \leq I_{OUT} \leq 40mA$	-	17	90	
Output Voltage	V_{OUT}	1	$-35V \leq V_{IN} \leq -23.5V$ $1.0mA \leq I_{OUT} \leq 40mA$	-21.0	-	-19.0	V	
			$V_{IN}=-29V$, $1.0mA \leq I_{OUT} \leq 70mA$	-21.0	-	-19.0		
Quiescent Current	I_B	1	$T_j=25^{\circ}C$	-	3.3	6.5	mA	
			$T_j=125^{\circ}C$	-	-	6.0		
Quiescent Current Change	ΔI_{BI}	1	$-35V \leq V_{IN} \leq -24V$	-	-	1.5	mA	
	ΔI_{BO}		$1.0mA \leq I_{OUT} \leq 40mA$	-	-	0.1		
Output Noise Voltage	V_{NO}	3	$T_a=25^{\circ}C$, $10Hz \leq f \leq 100kHz$	-	170	-	μV_{rms}	
Long Term Stability	$\Delta V_{OUT}/\Delta t$	1		-	49	-	mV/ 1.0kHrs	
Ripple Rejection Ratio	RR	2	$-35V \leq V_{IN} \leq -27V$, $T_j=25^{\circ}C$, $f=120Hz$	31	37	-	dB	
Dropout Voltage	$ V_{IN}-V_{OUT} $	1	$T_j=25^{\circ}C$, $I_{OUT}=40mA$	-	1.7	-	V	
Average Temperature Coefficient of Output Voltage	TC_{VO}	1	$I_{OUT}=5mA$	-	-1.7	-	mV/ $^{\circ}C$	

KIA79L05F ~ KIA79L24F

ELECTRICAL CHARACTERISTICS

KIA79L24F

(Unless otherwise specified, $V_{IN} = -33V$, $I_{OUT} = 40mA$, $C_{IN} = 0.33\mu F$, $C_{OUT} = 0.1\mu F$, $0^{\circ}C \leq T_j \leq 125^{\circ}C$)

CHARACTERISTIC	SYMBOL	TEST CIRCUIT	TEST CONDITION	MIN.	TYP.	MAX.	UNIT	
Output Voltage	V_{OUT}	1	$T_j = 25^{\circ}C$	-25.0	-24.0	-23.0	V	
Input Regulation	Reg line	1	$T_j = 25^{\circ}C$	-38V \leq V_{IN} \leq -27V	-	35	350	mV
				-38V \leq V_{IN} \leq -28V	-	30	300	
Load Regulation	Reg load	1	$T_j = 25^{\circ}C$	$1.0mA \leq I_{OUT} \leq 100mA$	-	40	200	mV
				$1.0mA \leq I_{OUT} \leq 40mA$	-	20	100	
Output Voltage	V_{OUT}	1		-38V \leq V_{IN} \leq -27V $1.0mA \leq I_{OUT} \leq 40mA$	-25.2	-	-22.8	V
				$V_{IN} = -33V$, $1.0mA \leq I_{OUT} \leq 70mA$	-25.2	-	-22.8	
Quiescent Current	I_B	1	$T_j = 25^{\circ}C$		-	3.5	6.5	mA
			$T_j = 125^{\circ}C$		-	-	6.0	
Quiescent Current Change	ΔI_{BI}	1		-38V \leq V_{IN} \leq -28V	-	-	1.5	mA
	ΔI_{BO}			$1.0mA \leq I_{OUT} \leq 40mA$	-	-	0.1	
Output Noise Voltage	V_{NO}	3	$T_a = 25^{\circ}C$, $10Hz \leq f \leq 100kHz$	-	200	-	μV_{rms}	
Long Term Stability	$\Delta V_{OUT}/\Delta t$	1		-	56	-	mV/ 1.0kHrs	
Ripple Rejection Ratio	RR	2	-35V \leq V_{IN} \leq -29V, $T_j = 25^{\circ}C$, $f = 120Hz$	31	47	-	dB	
Dropout Voltage	$ V_{IN} - V_{OUT} $	1	$T_j = 25^{\circ}C$, $I_{OUT} = 40mA$	-	1.7	-	V	
Average Temperature Coefficient of Output Voltage	TC_{VO}	1	$I_{OUT} = 5mA$	-	-2.0	-	mV/ $^{\circ}C$	

KIA79L05F ~ KIA79L24F

TEST CIRCUIT 1

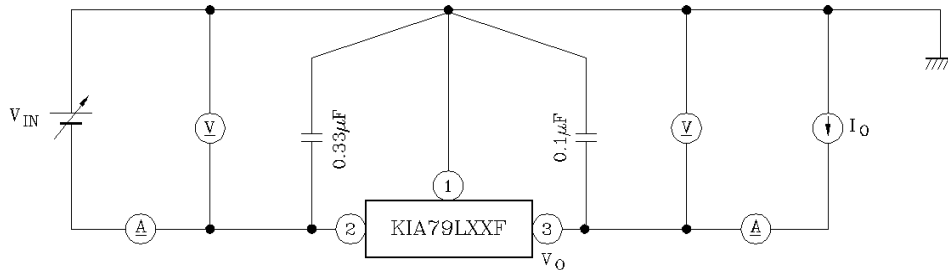

TEST CIRCUIT 2

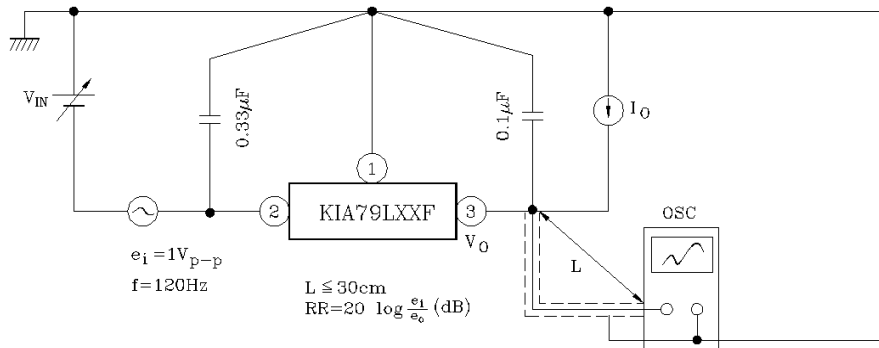

TEST CIRCUIT 3

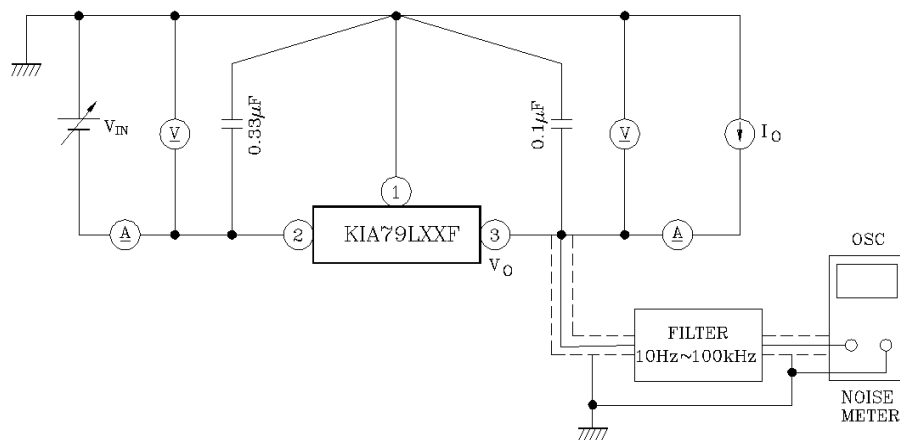

KIA79L05F ~ KIA79L24F

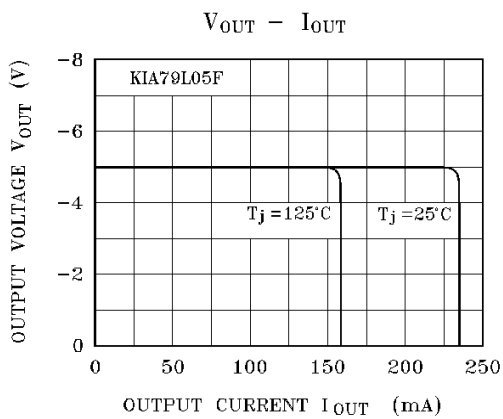
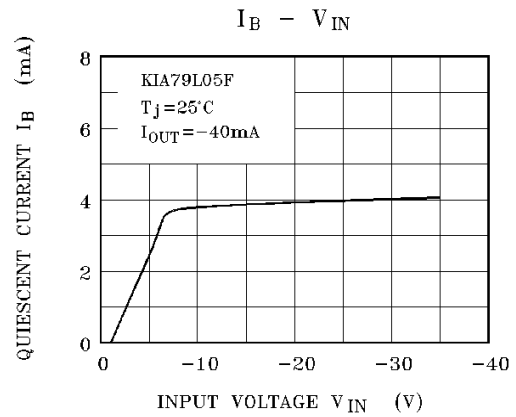
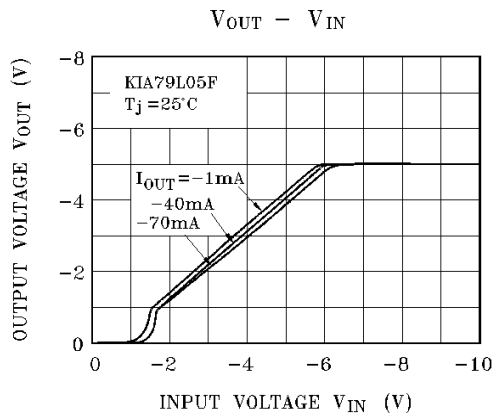
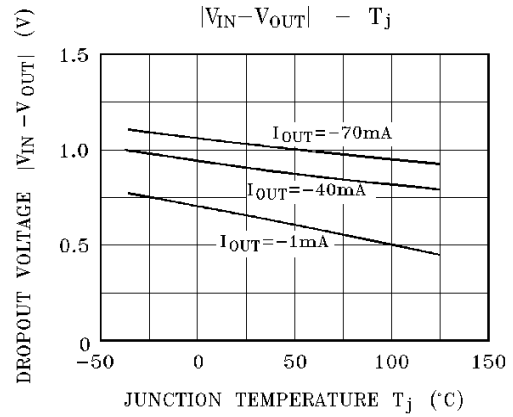
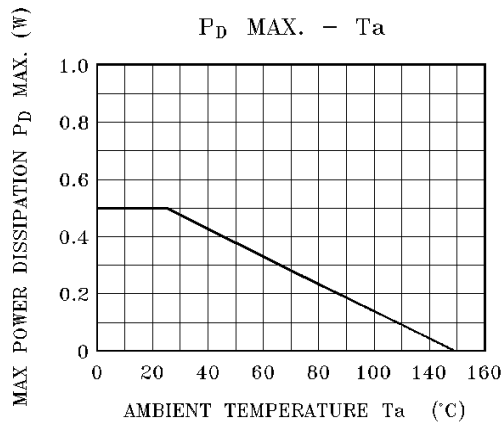

KIA79L05F ~ KIA79L24F

PRECAUTIONS FOR USE

SOLDERING

Flat Package (SOT-89 Package)

Elements mounting styles of electronic devices are gaining in further diversification over recent years, and needs for components are all the more expanding in varieties. Especially, surface mounting is steadily penetrating into industrial segments as a world-wide popular technical trend. Although exposure to high temperature is inevitable during soldering we recommend limiting the soldering temperature to low levels as shown in figure for the sake of retaining inherent excellent reliability.

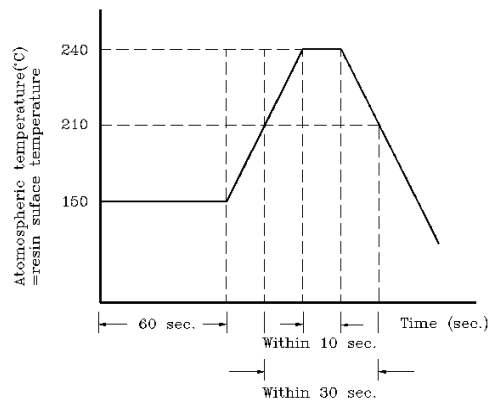

(a) When employing solder reflow method

- ① Atmospheric temperature around resin surfaces must be less than 240°C, not exceeding the time length of 10 sec.
- ② Recommend temperature profile
- ③ Precautions on heating method

When resin is kept exposed to high temperature for a long time, device reliability may be marred. Therefore, it is essential to complete soldering in the shortest time possible to prevent temperature of resin from rising.

(b) When employing halogen lamps or infrared-ray heaters

When halogen lamps or infrared-ray heaters are used, avoid direct irradiation onto resin surfaces ; such devices cause extensive localized temperature rise.

※ Please keep a reflow solder operating when SOT-89 package's soldering.