

OKI electronic components

KGF1256B/1256

Medium-Power Amplifier

GENERAL DESCRIPTION

The KGF1256B is a medium-power amplifier, with frequencies ranging from the UHF-band to the L-band, that features high output power, low noise, and low current operation. The KGF1256B specifications are guaranteed to a fixed matching circuit for 5 V and 850 MHz; external impedance-matching circuits are also required. Because of the low noise and high output power at the low operating current, the KGF1256B is ideal as a transmitter-driver amplifier for personal handy phones.

The KGF1256 is similar to the KGF1256B in specifications and typical properties. Although having S Parameters that are slightly different from those of the KGF1256B, the KGF1256 meets the specifications for the KGF1256B, even with the same matching circuits.

FEATURES

- High output power: 15 dBm (min.)
- Low noise: 2.5 dB (max.)
- Low current: 40 mA (max.)
- Self-bias circuit configuration with built-in source capacitor
- Package: 4PSOP

PACKAGE DIMENSIONS

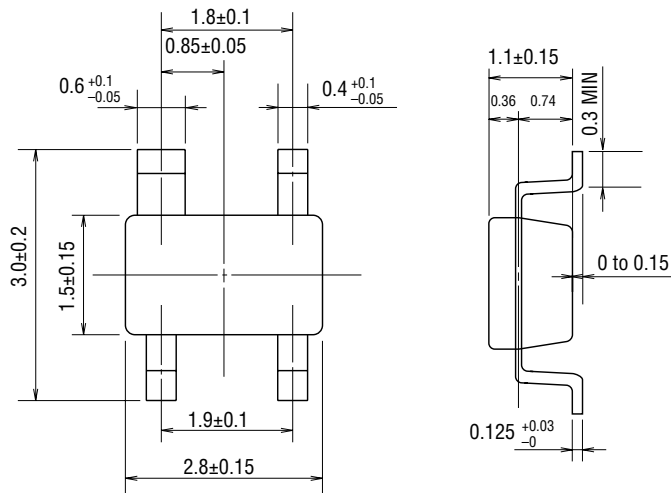

(Unit: mm)

Package material	Epoxy resin
Lead frame material	42 alloy
Pin treatment	Solder plating
Solder plate thickness	5 μm or more

Note: Ask our sales department for detailed requirements of the KGF1256.

MARKING

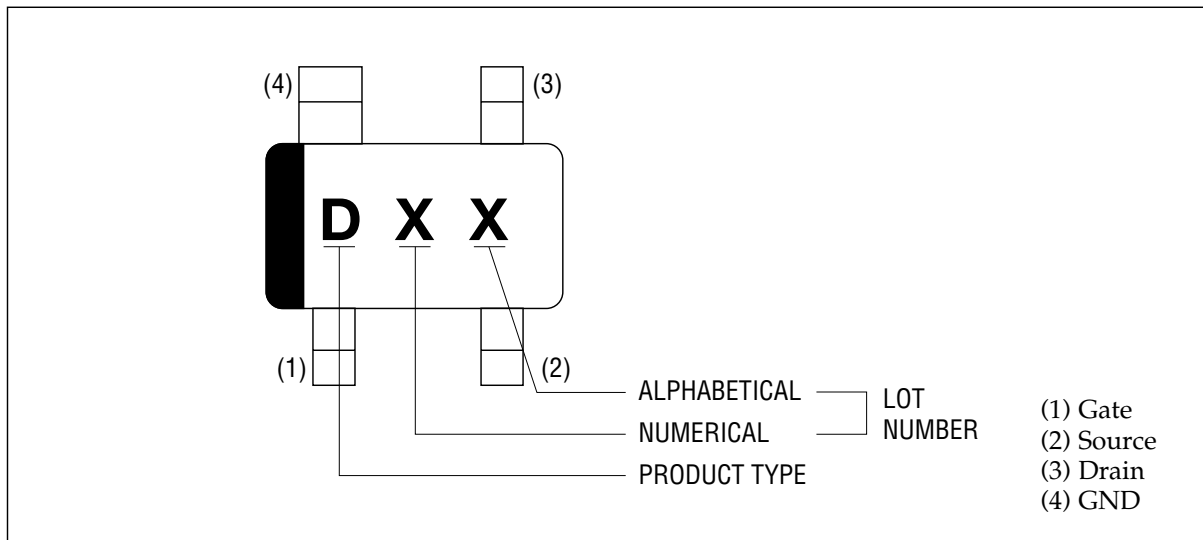

CIRCUIT

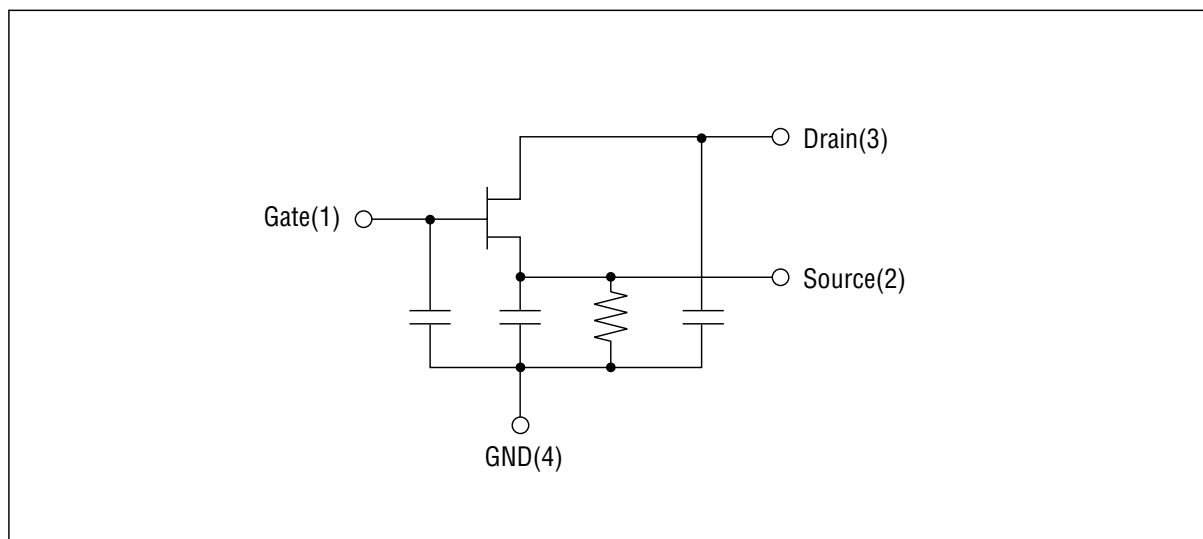

ABSOLUTE MAXIMUM RATINGS

Item	Symbol	Condition	Unit	Min.	Max.
Drain-source voltage	V_{DS}	$T_a = 25^\circ\text{C}$	V	—	7
Gate-source voltage	V_{GS}	$T_a = 25^\circ\text{C}$	V	-3.0	0.4
Drain current	I_{DS}	$T_a = 25^\circ\text{C}$	mA	—	360
Total power dissipation	P_{tot}	$T_a = 25^\circ\text{C}$	mW	—	300
Channel temperature	T_{ch}	—	$^\circ\text{C}$	—	150
Storage temperature	T_{stg}	—	$^\circ\text{C}$	-45	125

ELECTRICAL CHARACTERISTICS

(Ta = 25°C)

Item	Symbol	Condition	Unit	Min.	Typ.	Max.	
Gate-source leakage current	I_{GSS}	$V_{GS} = -3\text{ V}$	μA	—	—	72	
Gate-drain leakage current	I_{GDO}	$V_{GD} = -11\text{ V}$	μA	—	—	360	
Drain-source leakage current	$I_{DS(off)}$	$V_{DS} = 3\text{ V}, V_{GS} = -2\text{ V}$	μA	—	—	720	
Drain current	I_{DSS}	$V_{DS} = 3\text{ V}, V_{GS} = 0\text{ V}$	mA	100	—	—	
Operating current	I_D	(*1), $P_{IN} = 5\text{ dBm}$, $f = 850\text{ MHz}$	mA	—	—	40.0	
Gate-source cut-off voltage	$V_{GS(off)}$	$V_{DS} = 3\text{ V}, I_{DS} = 720\text{ }\mu\text{A}$	V	-1.5	—	-0.5	
Transconductance	g_m	$V_{DS} = 3\text{ V}, I_{DS} = 25\text{ mA}$	mS	100	—	—	
Noise figure	F	(*1), $f = 850\text{ MHz}$	dB	—	—	2.5	
Linear gain	G_{LIN}	(*1), $P_{IN} = -20\text{ dBm}$	$f = 850\text{ MHz}$	dB	14.0	18.0	—
			$f = 1.5\text{ GHz}$		—	13.0	—
			$f = 1.9\text{ GHz}$		—	10.5	—
		(*2), $P_{IN} = -20\text{ dBm}$	$f = 850\text{ MHz}$		—	18.0	—
			$f = 1.5\text{ GHz}$		—	12.5	—
			$f = 1.9\text{ GHz}$		—	10.0	—
Output power	P_O	(*1), $P_{IN} = 5\text{ dBm}$	$f = 850\text{ MHz}$	dBm	16.0	18.0	—
			$f = 1.5\text{ GHz}$		—	15.5	—
			$f = 1.9\text{ GHz}$		—	11.5	—
		(*2), $P_{IN} = 5\text{ dBm}$	$f = 850\text{ MHz}$		—	15.0	—
			$f = 1.5\text{ GHz}$		—	13.0	—
			$f = 1.9\text{ GHz}$		—	10.5	—

*1 Self-bias condition: $V_{DD} = 5 \pm 0.25\text{ V}$, $V_G = 0\text{ V}$ *2 Self-bias condition: $V_{DD} = 3\text{ V}$, $V_G = 0\text{ V}$

RF CHARACTERISTICS

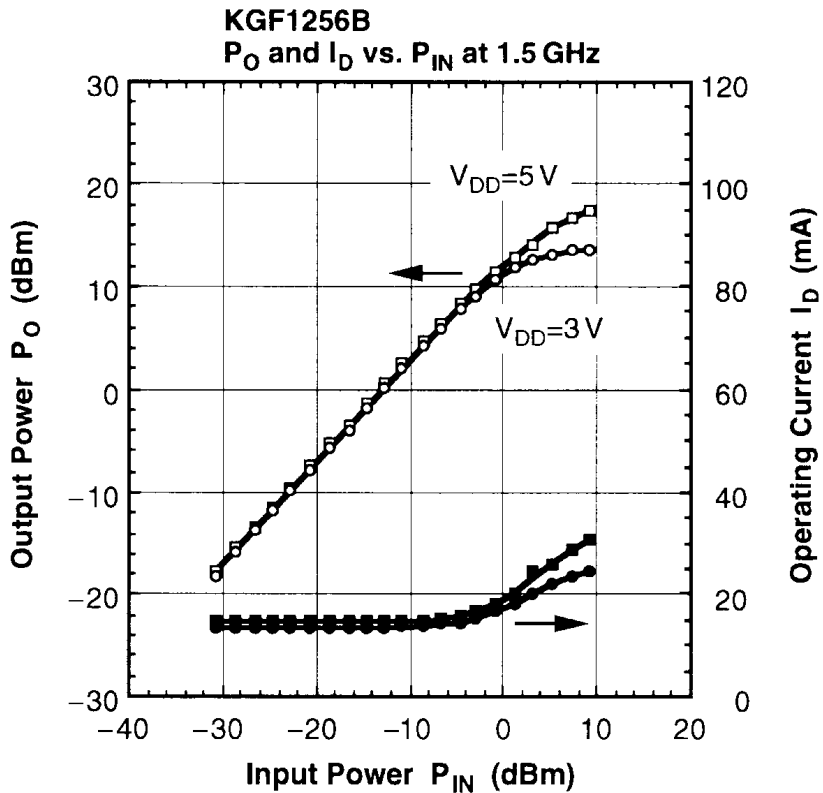
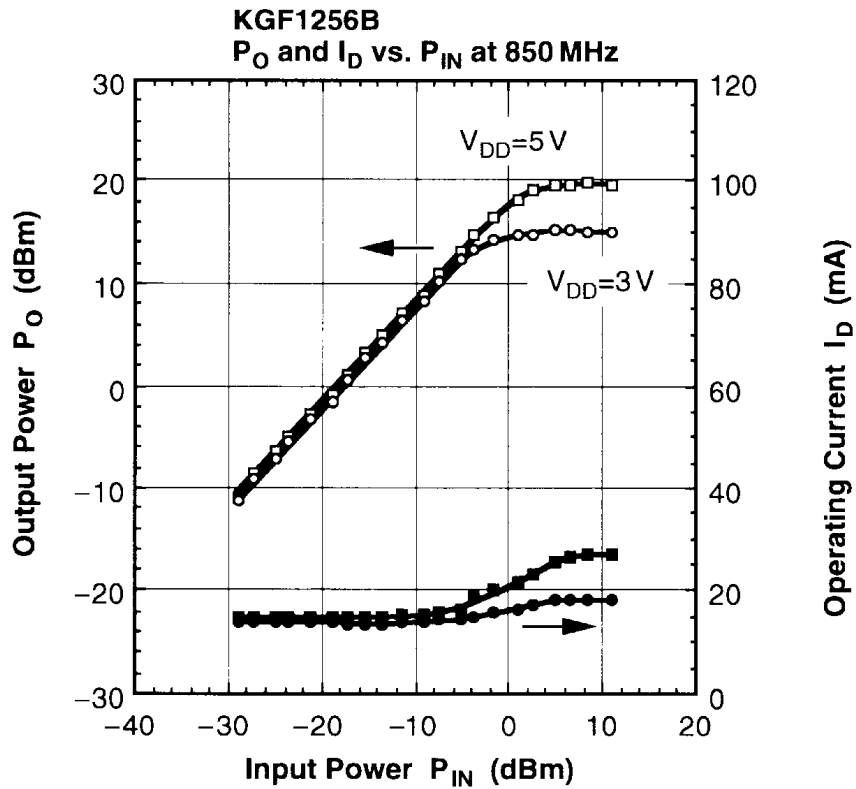

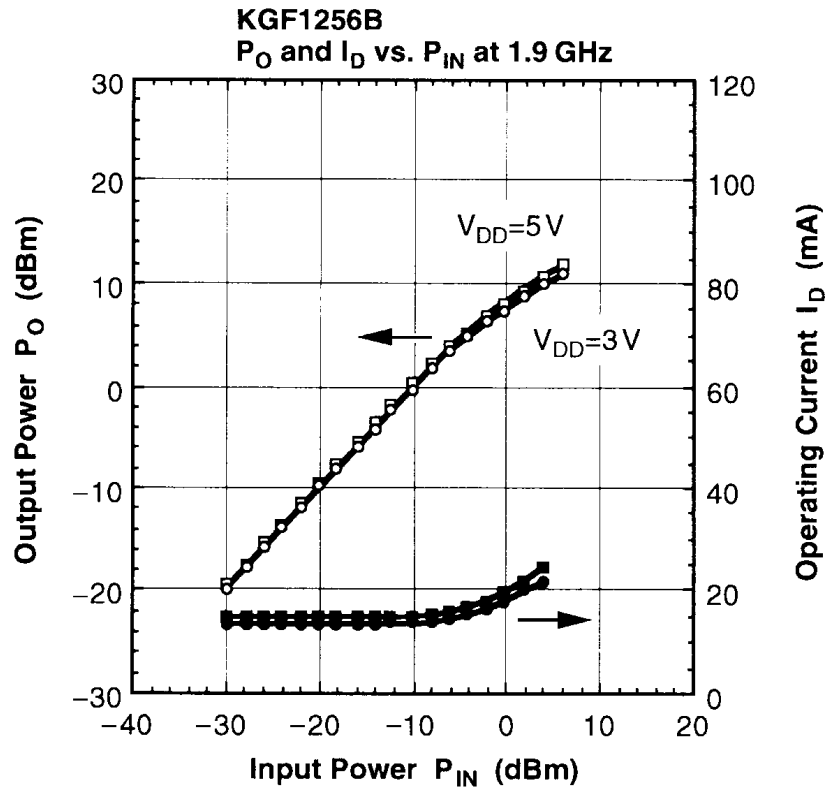

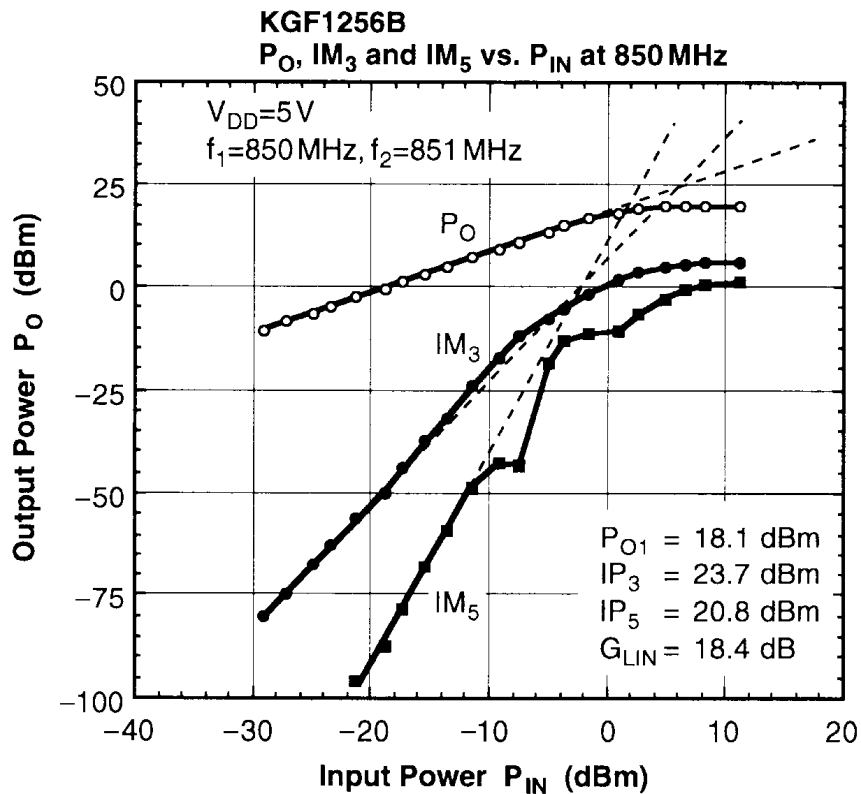
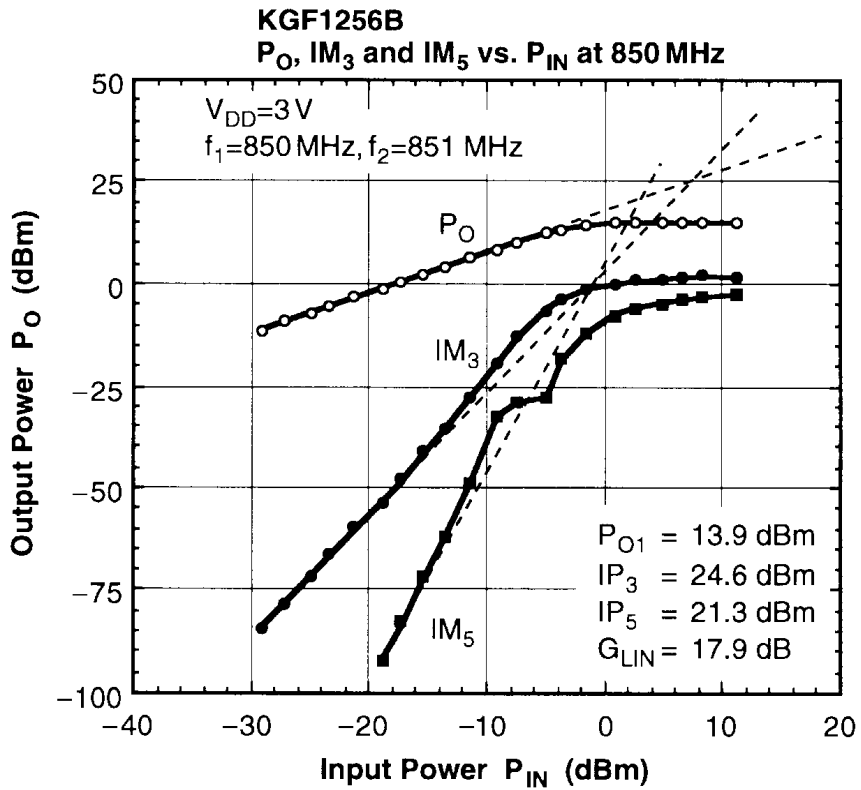

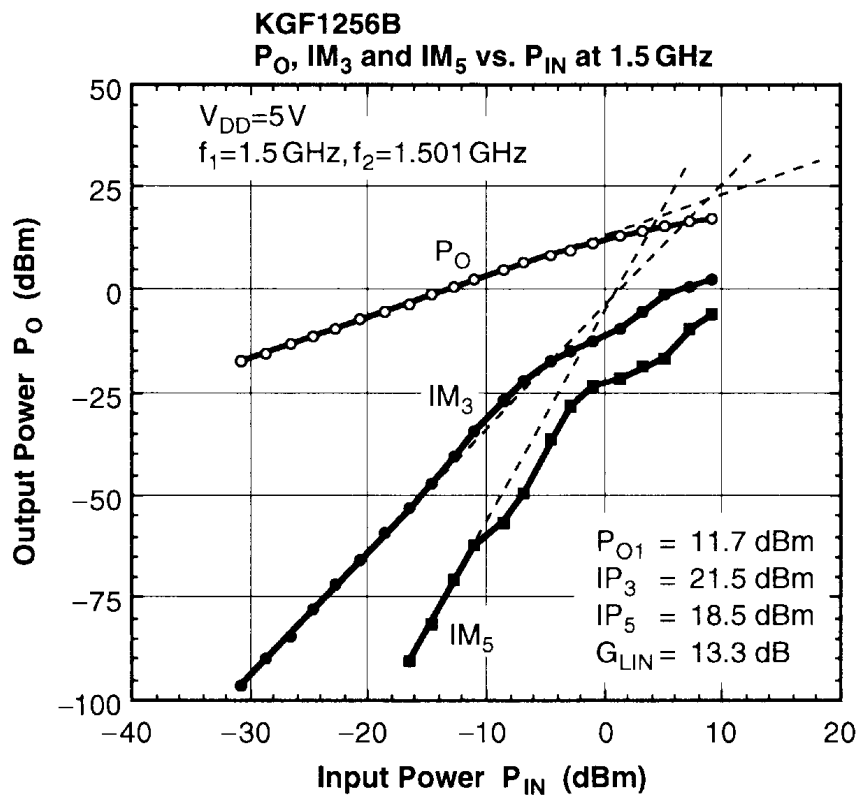
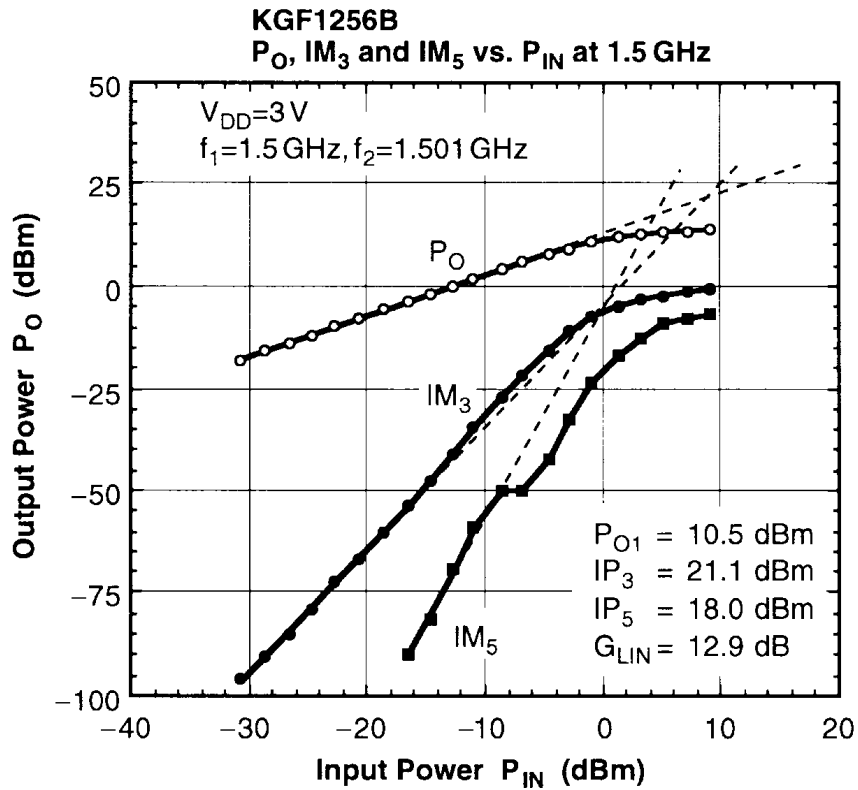

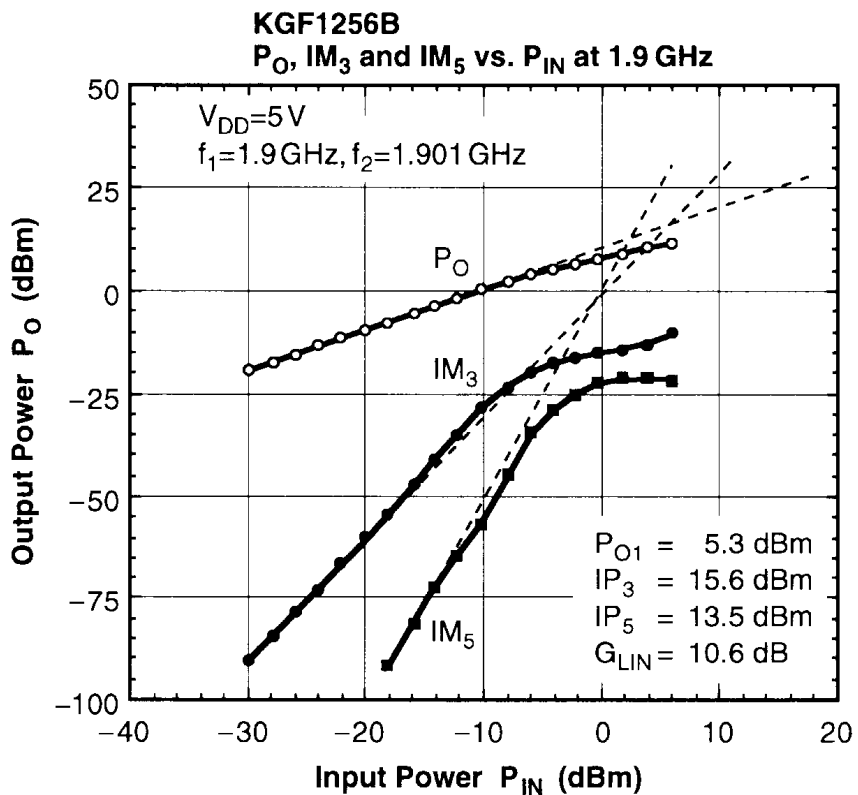
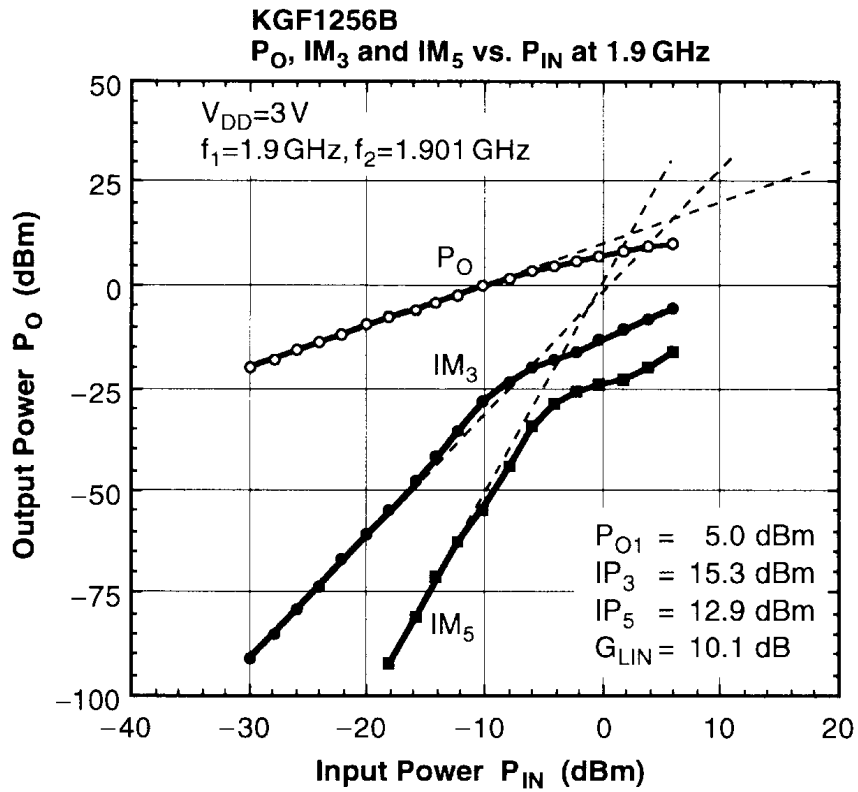

Typical S Parameters of KGF1256B

 $V_{DD} = 3\text{ V}$, $V_G = 0\text{ V}$, $I_D = 14.0\text{ mA}$

Freq(MHz)	MAG(S ₁₁)	ANG(S ₁₁)	MAG(S ₂₁)	ANG(S ₂₁)	MAG(S ₁₂)	ANG(S ₁₂)	MAG(S ₂₂)	ANG(S ₂₂)
500.0	0.941	-52.03	5.226	134.33	0.051	42.22	0.531	-76.18
600.0	0.917	-62.43	5.315	126.90	0.052	39.67	0.470	-86.88
700.0	0.874	-71.90	5.111	117.12	0.050	38.92	0.443	-94.46
800.0	0.837	-78.93	4.827	108.84	0.048	43.95	0.426	-99.94
900.0	0.806	-86.02	4.537	101.30	0.051	44.67	0.415	-105.46
1000.0	0.777	-92.27	4.238	94.02	0.052	52.24	0.412	-109.85
1100.0	0.755	-98.15	3.966	87.45	0.052	54.10	0.407	-114.89
1200.0	0.737	-102.90	3.730	81.35	0.057	61.31	0.412	-118.94
1300.0	0.720	-108.50	3.496	75.71	0.061	68.35	0.413	-123.38
1400.0	0.710	-113.18	3.307	70.03	0.066	68.45	0.428	-127.26
1500.0	0.703	-117.55	3.145	65.11	0.077	73.21	0.435	-131.30
1600.0	0.700	-122.22	2.968	59.63	0.082	74.54	0.446	-136.06
1700.0	0.693	-126.28	2.830	55.27	0.093	76.69	0.454	-139.61
1800.0	0.691	-131.15	2.672	51.43	0.104	76.81	0.461	-143.33
1900.0	0.696	-135.24	2.559	45.44	0.115	78.98	0.481	-147.66
2000.0	0.693	-139.61	2.432	40.78	0.131	77.39	0.494	-151.56
2100.0	0.693	-144.32	2.310	36.30	0.146	77.41	0.500	-156.02
2200.0	0.695	-147.69	2.205	32.02	0.159	73.86	0.520	-160.73
2300.0	0.704	-152.62	2.092	27.18	0.174	73.40	0.534	-164.01
2400.0	0.702	-156.91	2.006	23.36	0.194	70.69	0.547	-169.05
2500.0	0.707	-161.26	1.898	19.63	0.210	66.14	0.570	-172.95
2600.0	0.716	-165.51	1.816	15.30	0.223	65.02	0.576	-177.32
2700.0	0.719	-170.07	1.732	11.81	0.243	61.54	0.597	178.74
2800.0	0.719	-174.51	1.646	8.05	0.253	58.95	0.607	174.30
2900.0	0.727	-178.84	1.561	4.42	0.269	56.33	0.614	169.67
3000.0	0.731	177.05	1.492	0.51	0.283	53.45	0.630	165.37

Typical S Parameters of KGF1256B

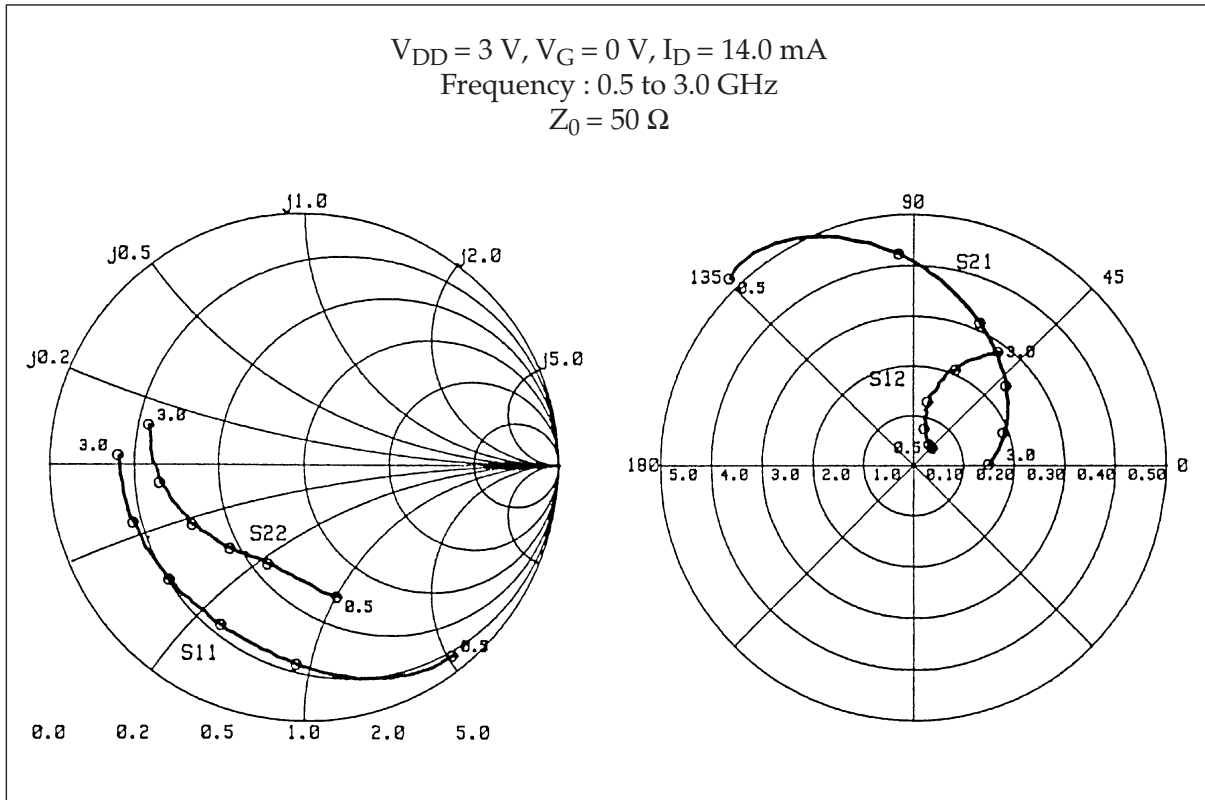

Typical S Parameters of KGF1256B

 $V_{DD} = 5\text{ V}$, $V_G = 0\text{ V}$, $I_D = 15.4\text{ mA}$

Freq(MHz)	MAG(S ₁₁)	ANG(S ₁₁)	MAG(S ₂₁)	ANG(S ₂₁)	MAG(S ₁₂)	ANG(S ₁₂)	MAG(S ₂₂)	ANG(S ₂₂)
500.0	0.946	-50.39	5.163	134.98	0.046	41.95	0.531	-72.83
600.0	0.929	-60.59	5.261	127.92	0.044	42.66	0.469	-82.56
700.0	0.888	-69.71	5.067	118.20	0.043	43.75	0.439	-89.70
800.0	0.849	-77.00	4.808	109.79	0.043	47.27	0.426	-94.94
900.0	0.819	-83.83	4.532	102.16	0.045	46.06	0.420	-99.99
1000.0	0.798	-90.00	4.249	94.87	0.044	60.51	0.414	-104.80
1100.0	0.772	-95.94	3.991	88.30	0.045	62.09	0.407	-109.30
1200.0	0.754	-101.07	3.747	81.91	0.052	68.42	0.414	-113.96
1300.0	0.737	-106.32	3.514	76.24	0.057	76.71	0.424	-118.19
1400.0	0.734	-111.29	3.326	70.45	0.066	76.64	0.437	-122.15
1500.0	0.725	-115.68	3.174	65.44	0.074	81.63	0.442	-126.67
1600.0	0.719	-120.16	2.997	59.74	0.082	84.47	0.451	-131.24
1700.0	0.714	-124.65	2.860	55.18	0.096	85.33	0.460	-134.86
1800.0	0.712	-129.15	2.700	50.32	0.106	81.95	0.475	-138.98
1900.0	0.720	-133.48	2.585	45.17	0.117	83.83	0.490	-143.98
2000.0	0.715	-137.90	2.467	40.55	0.136	82.48	0.509	-147.62
2100.0	0.716	-142.76	2.331	35.99	0.151	83.14	0.517	-152.36
2200.0	0.720	-146.59	2.229	31.65	0.165	78.59	0.539	-156.77
2300.0	0.726	-151.65	2.108	26.60	0.184	76.66	0.551	-160.66
2400.0	0.726	-155.82	2.017	22.47	0.202	75.03	0.563	-165.98
2500.0	0.730	-160.35	1.907	19.12	0.218	71.03	0.583	-169.93
2600.0	0.736	-164.80	1.825	14.31	0.237	67.89	0.595	-174.37
2700.0	0.742	-169.18	1.734	10.62	0.252	64.26	0.611	-179.30
2800.0	0.742	-173.83	1.648	7.08	0.267	60.87	0.623	176.68
2900.0	0.746	-178.20	1.566	3.43	0.285	57.36	0.632	171.64
3000.0	0.753	177.40	1.494	-0.62	0.296	55.75	0.648	167.22

Typical S Parameters of KGF1256B

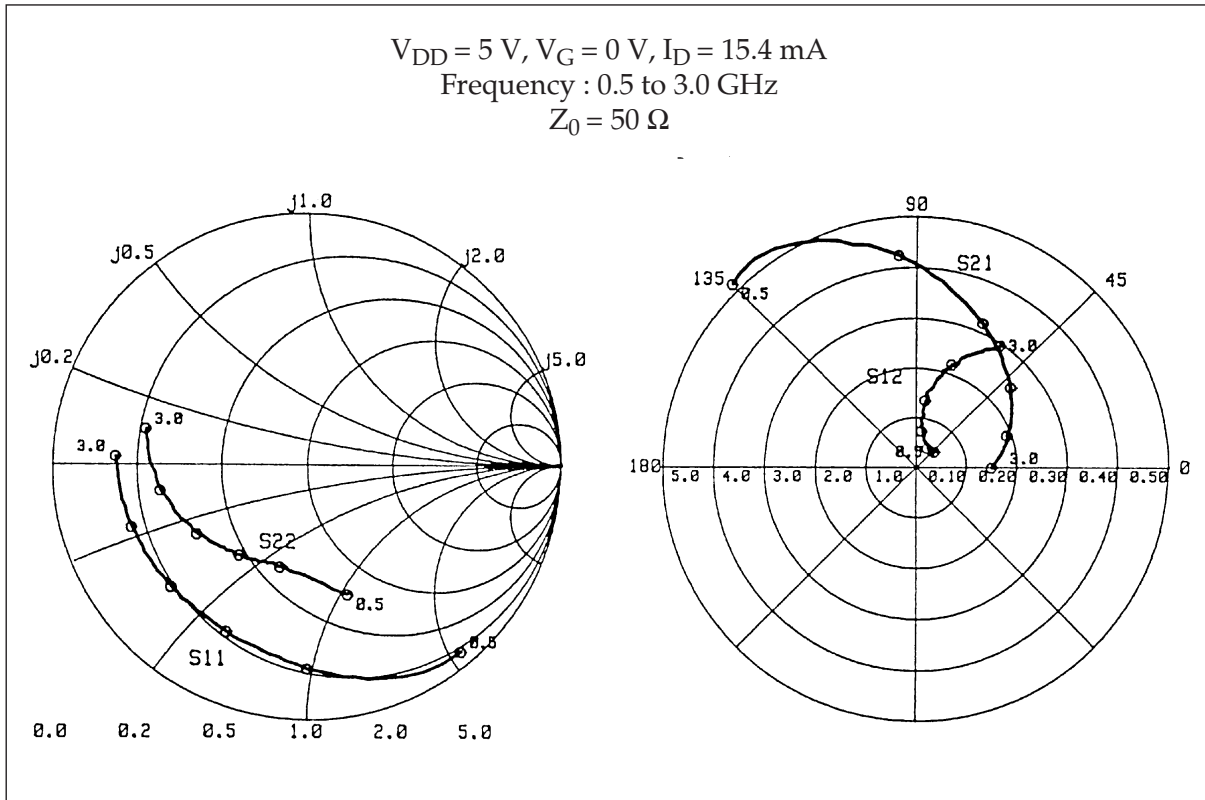

Test Circuit and Bias Configuration for KGF1256B at 850 MHz

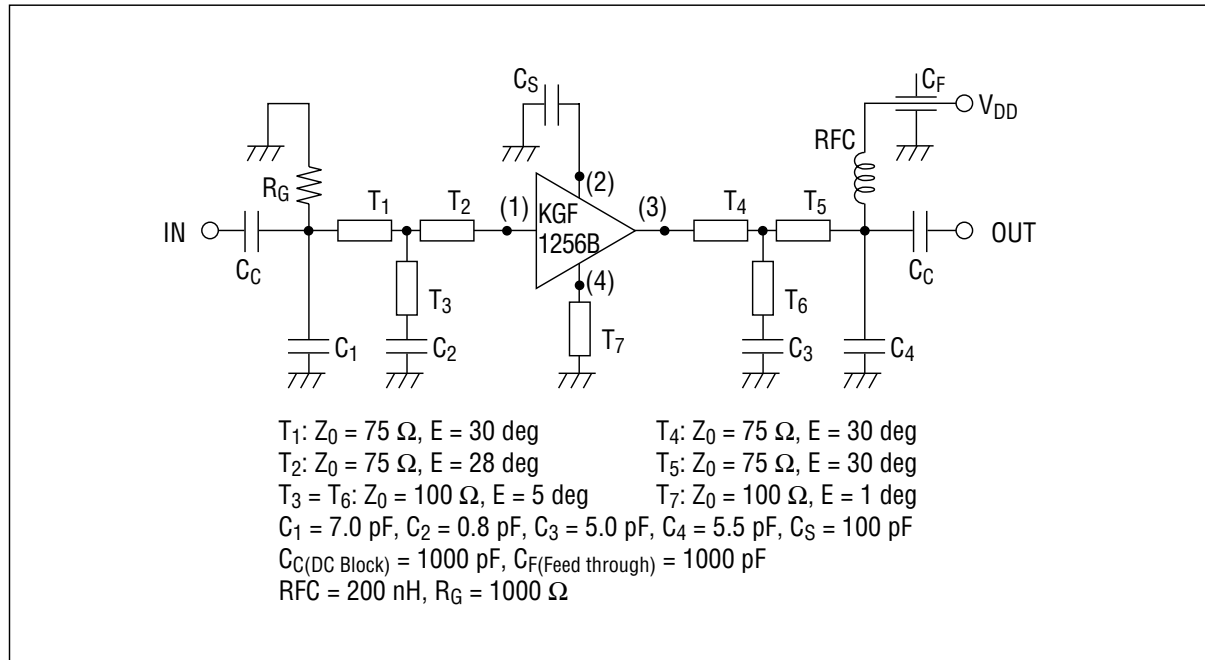

Test Circuit and Bias Configuration for KGF1256B at 1.5 GHz

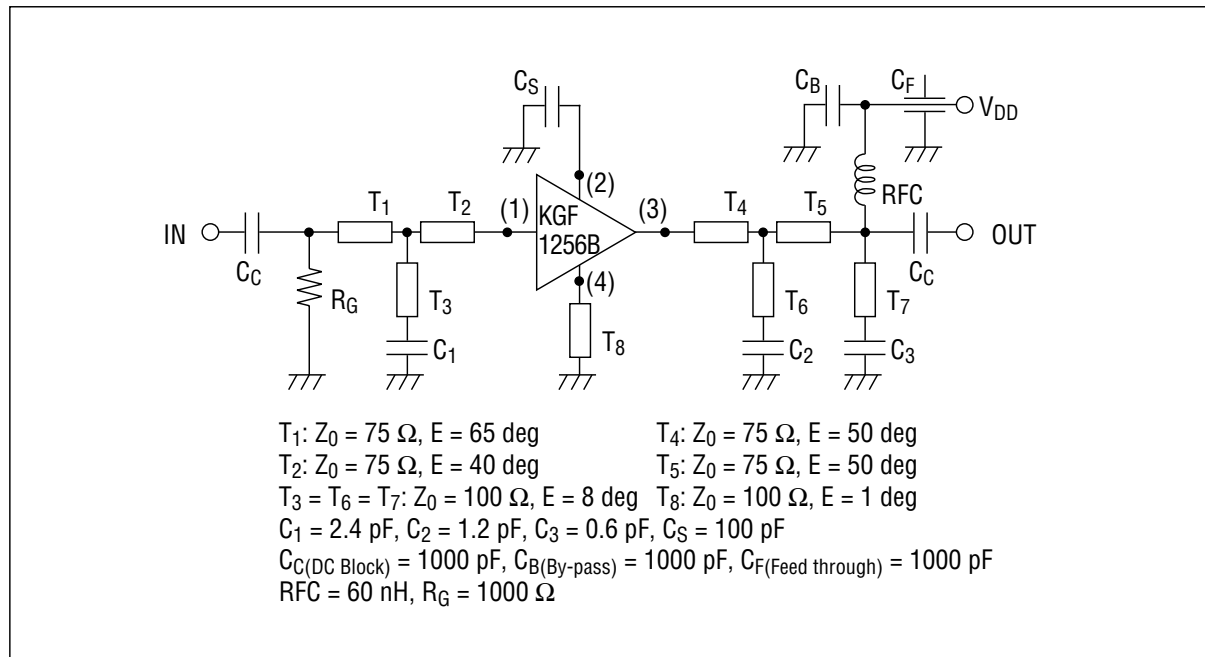

Test Circuit and Bias Configuration for KGF1256B at 1.9 GHz

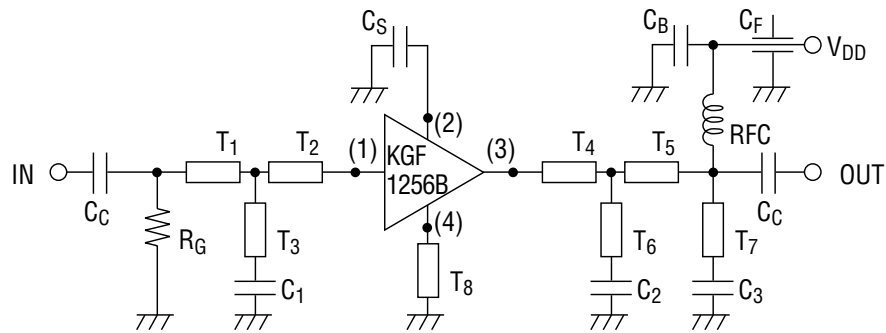

$T_1: Z_0 = 75 \Omega, E = 65 \text{ deg}$ $T_4: Z_0 = 75 \Omega, E = 50 \text{ deg}$
 $T_2: Z_0 = 75 \Omega, E = 40 \text{ deg}$ $T_5: Z_0 = 75 \Omega, E = 50 \text{ deg}$
 $T_3 = T_6 = T_7: Z_0 = 100 \Omega, E = 1 \text{ deg}$ $T_8: Z_0 = 100 \Omega, E = 1 \text{ deg}$
 $C_1 = 1.7 \text{ pF}, C_2 = 1.3 \text{ pF}, C_3 = 0.2 \text{ pF}, C_S = 100 \text{ pF}$
 $C_C(\text{DC Block}) = 1000 \text{ pF}, C_B(\text{By-pass}) = 1000 \text{ pF}, C_F(\text{Feed through}) = 1000 \text{ pF}$
 $\text{RFC} = 60 \text{ nH}, R_G = 1000 \Omega$