

VHF TUNER BAND SWITCH APPLICATIONS.

FEATURES

- Small Package.
- Small Total Capacitance : $C_T=1.2\text{pF(Max.)}$.
- Low Series Resistance : $r_s=0.5\Omega$ (Typ.).

MAXIMUM RATINGS (Ta=25°C)

CHARACTERISTIC	SYMBOL	RATING	UNIT
Reverse Voltage	V_R	30	V
Forward Current	I_F	100	mA
Junction Temperature	T_j	150	°C
Storage Temperature Range	T_{stg}	-55 ~ 150	°C

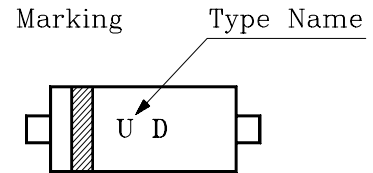
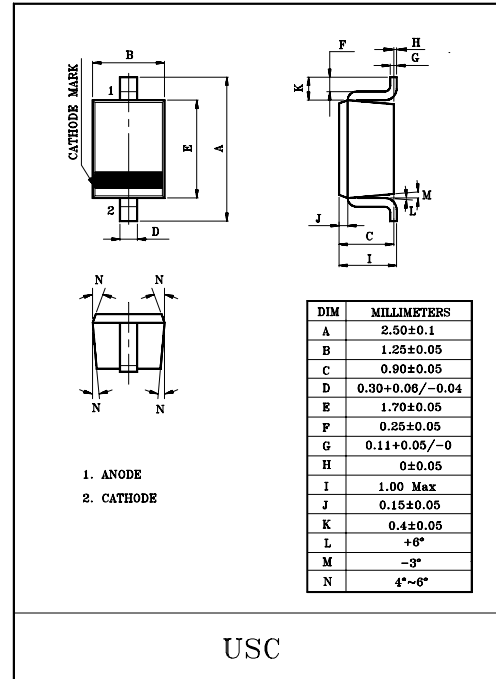

ELECTRICAL CHARACTERISTICS (Ta=25°C)

CHARACTERISTIC	SYMBOL	TEST CONDITION	MIN.	TYP.	MAX.	UNIT
Forward Voltage	V_F	$I_F=2\text{mA}$	-	-	0.85	V
Reverse Current	I_R	$V_R=15\text{V}$	-	-	0.1	μA
Reverse Voltage	V_R	$I_R=1\mu\text{A}$	30	-	-	V
Total Capacitance	C_T	$V_R=6\text{V}, f=1\text{MHz}$	-	0.7	1.2	pF
Series Resistance	r_s	$I_F=2\text{mA}, f=100\text{MHz}$	-	0.5	0.9	Ω

