

DATA SHEET

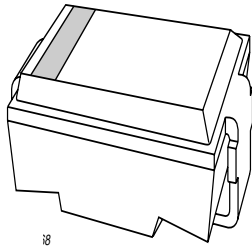

BZG04 series Transient voltage suppressor diodes

Preliminary specification
Supersedes data of 1996 Jun 10

1996 Sep 19

Transient voltage suppressor diodes

BZG04 series

FEATURES

- Glass passivated
- High maximum operating temperature
- Low leakage current
- Excellent stability
- UL 94V-O classified plastic package
- Transient suppressor stand-off voltage range:
8.2 to 220 V for 32 types
- Shipped in 12 mm embossed tape.

DESCRIPTION

DO-214AC surface mountable package with glass passivated chip.

The well-defined void-free case is of a transfer-moulded thermo-setting plastic.

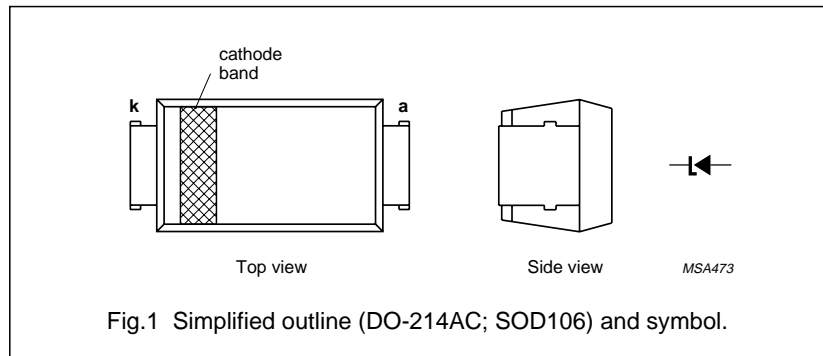

LIMITING VALUES

In accordance with the Absolute Maximum Rating System (IEC 134).

SYMBOL	PARAMETER	CONDITIONS	MIN.	MAX.	UNIT
P_{RSM}	non-repetitive peak reverse power dissipation	10/1 000 μ s exponential pulse (see Fig.4); $T_j = 25^\circ\text{C}$ prior to surge; see also Fig.2	–	300	W
T_{stg}	storage temperature		–65	+175	$^\circ\text{C}$
T_j	junction temperature		–65	+175	$^\circ\text{C}$

Transient voltage suppressor diodes

BZG04 series

ELECTRICAL CHARACTERISTICS

Total series

$T_j = 25\text{ }^\circ\text{C}$ unless otherwise specified.

SYMBOL	PARAMETER	CONDITIONS	MIN.	MAX.	UNIT
V_F	forward voltage	$I_F = 0.5\text{ A}$; see Fig.3	–	1.2	V

Per type

$T_j = 25\text{ }^\circ\text{C}$ unless otherwise specified.

TYPE NUMBER	REVERSE BREAKDOWN VOLTAGE	TEMPERATURE COEFFICIENT		TEST CURRENT	CLAMPING VOLTAGE		REVERSE CURRENT at STAND-OFF VOLTAGE	
	$V_{(BR)R}$ (V) at I_{test}	S_Z (%/K) at I_{test}		I_{test} (mA)	$V_{(CL)R}$ (V)	at I_{RSM} (A) note 1	I_R (μA)	at V_R (V)
	MIN.	MIN.	MAX.		MAX.		MAX.	
BZG04-8V2	9.4	0.05	0.09	50	14.8	20.3	20	8.2
BZG04-9V1	10.4	0.05	0.10	50	15.7	19.1	5	9.1
BZG04-10	11.4	0.05	0.10	50	17.0	17.7	5	10
BZG04-11	12.4	0.05	0.10	50	18.9	15.9	5	11
BZG04-12	13.8	0.05	0.10	50	20.9	14.4	5	12
BZG04-13	15.3	0.06	0.11	25	22.9	13.1	5	13
BZG04-15	16.8	0.06	0.11	25	25.6	11.7	5	15
BZG04-16	18.8	0.06	0.11	25	28.4	10.6	5	16
BZG04-18	20.8	0.06	0.11	25	31.0	9.7	5	18
BZG04-20	22.8	0.06	0.11	25	33.8	8.9	5	20
BZG04-22	25.1	0.06	0.11	25	38.1	7.9	5	22
BZG04-24	28	0.06	0.11	25	42.2	7.1	5	24
BZG04-27	31	0.06	0.11	25	46.2	6.5	5	27
BZG04-30	34	0.06	0.11	10	50.1	6.0	5	30
BZG04-33	37	0.06	0.11	10	54.1	5.5	5	33
BZG04-36	40	0.07	0.12	10	60.7	4.9	5	36
BZG04-39	44	0.07	0.12	10	65.5	4.6	5	39
BZG04-43	48	0.07	0.12	10	70.8	4.2	5	43
BZG04-47	52	0.07	0.12	10	78.6	3.8	5	47
BZG04-51	58	0.08	0.13	10	86.5	3.5	5	51
BZG04-56	64	0.08	0.13	10	94.4	3.2	5	56
BZG04-62	70	0.08	0.13	10	103.5	2.9	5	62
BZG04-68	77	0.08	0.13	10	114	2.6	5	68
BZG04-75	85	0.09	0.13	5	126	2.4	5	75
BZG04-82	94	0.09	0.13	5	139	2.2	5	82
BZG04-91	104	0.09	0.13	5	152	2.0	5	91
BZG04-100	114	0.09	0.13	5	167	1.8	5	100

Transient voltage suppressor diodes

BZG04 series

TYPE NUMBER	REVERSE BREAKDOWN VOLTAGE	TEMPERATURE COEFFICIENT		TEST CURRENT	CLAMPING VOLTAGE		REVERSE CURRENT at STAND-OFF VOLTAGE	
	$V_{(BR)R}$ (V) at I_{test}	S_Z (%/K) at I_{test}		I_{test} (mA)	$V_{(CL)R}$ (V)	at I_{RSM} (A) note 1	I_R (μ A)	at V_R (V)
	MIN.	MIN.	MAX.		MAX.		MAX.	
BZG04-110	124	0.09	0.13	5	185	1.6	5	110
BZG04-120	138	0.09	0.13	5	204	1.5	5	120
BZG04-130	153	0.09	0.13	5	224	1.3	5	130
BZG04-150	168	0.09	0.13	5	249	1.2	5	150
BZG04-160	188	0.09	0.13	5	276	1.1	5	160
BZG04-180	208	0.09	0.13	2	305	1.0	5	180
BZG04-200	228	0.09	0.13	2	336	0.9	5	200
BZG04-220	251	0.09	0.13	2	380	0.8	5	220

Note

1. Non-repetitive peak reverse current in accordance with "IEC 60-1, Section 8" (10/1000 μ s pulse); see Fig.4.

THERMAL CHARACTERISTICS

SYMBOL	PARAMETER	CONDITIONS	VALUE	UNIT
$R_{th\ j-tp}$	thermal resistance from junction to tie-point		25	K/W
$R_{th\ j-a}$	thermal resistance from junction to ambient	note 1	100	K/W
		note 2	150	K/W

Notes

1. Device mounted on an Al_2O_3 printed-circuit board, 0.7 mm thick; thickness of Cu-layer $\geq 35\ \mu$ m, see Fig.5.
2. Device mounted on an epoxy-glass printed-circuit board, 1.5 mm thick; thickness of Cu-layer $\geq 40\ \mu$ m, see Fig.5.
For more information please refer to the "General Part of associated Handbook".

Transient voltage suppressor diodes

BZG04 series

GRAPHICAL DATA

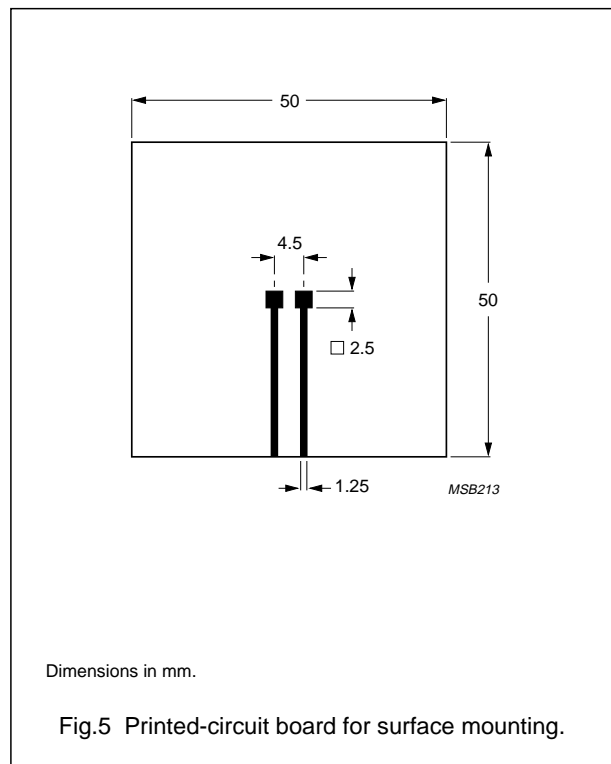
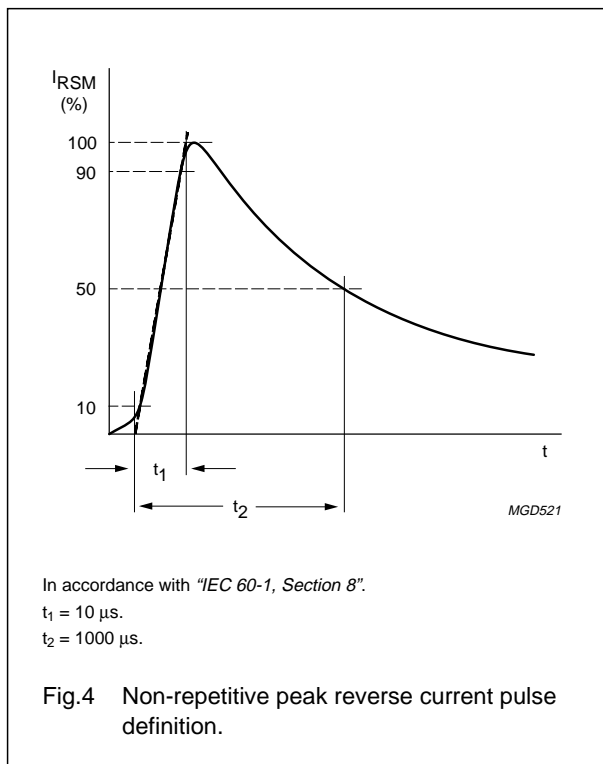
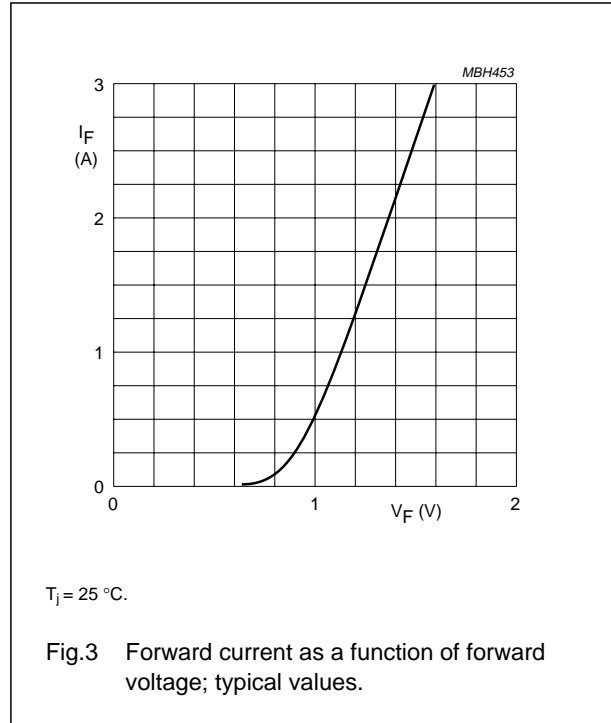
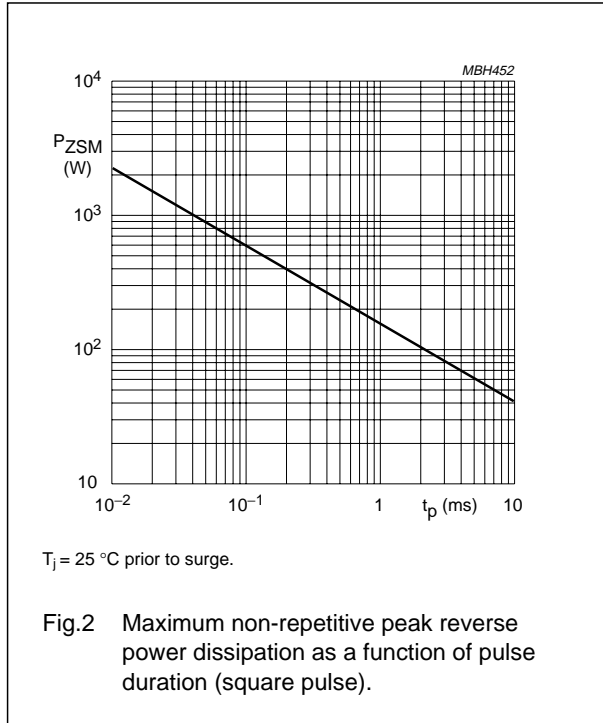

Transient voltage suppressor diodes

BZG04 series

PACKAGE OUTLINE

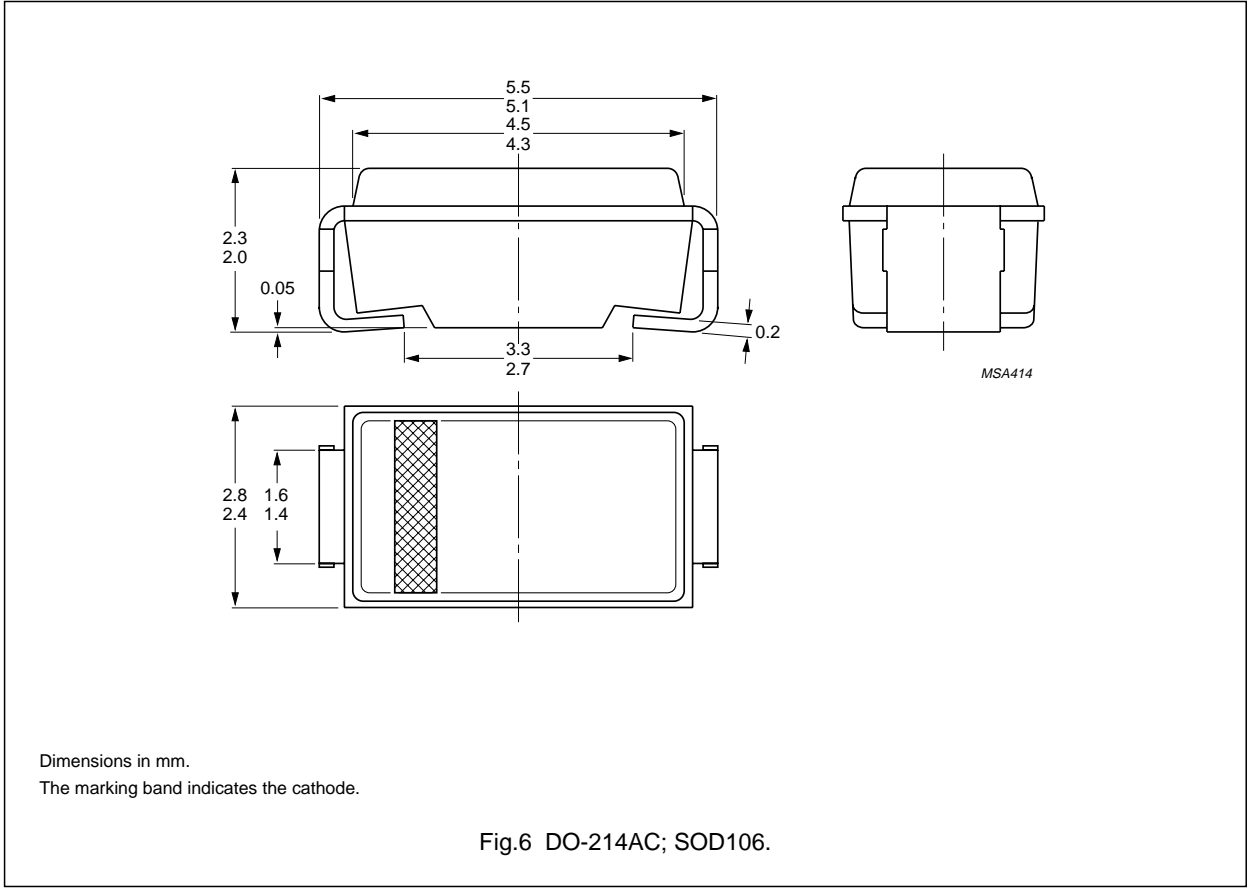

 Transient voltage suppressor diodes

BZG04 series

DEFINITIONS

Data sheet status	
Objective specification	This data sheet contains target or goal specifications for product development.
Preliminary specification	This data sheet contains preliminary data; supplementary data may be published later.
Product specification	This data sheet contains final product specifications.
Limiting values	
Limiting values given are in accordance with the Absolute Maximum Rating System (IEC 134). Stress above one or more of the limiting values may cause permanent damage to the device. These are stress ratings only and operation of the device at these or at any other conditions above those given in the Characteristics sections of the specification is not implied. Exposure to limiting values for extended periods may affect device reliability.	
Application information	
Where application information is given, it is advisory and does not form part of the specification.	

LIFE SUPPORT APPLICATIONS

These products are not designed for use in life support appliances, devices, or systems where malfunction of these products can reasonably be expected to result in personal injury. Philips customers using or selling these products for use in such applications do so at their own risk and agree to fully indemnify Philips for any damages resulting from such improper use or sale.