

## Silicon Variable Capacitance Diode

**Description**

The 1T363 is a variable capacitance diode designed for electronic tuning of CATV tuner, and super miniature package allows the tuner miniaturization.

**Features**

- Super miniature package
- Low series resistance 0.80 Ω Max. (f=470 MHz)
- Large capacitance ratio 15 Typ. (C<sub>1</sub>/C<sub>28</sub>)
- Small leakage current 10 nA Max. (V<sub>R</sub>=28 V)
- Maximum capacitance deviation  
3 % Max.

**Applications**

Electronic tuning for TV, CATV

**Structure**

Silicon epitaxial planar type diode

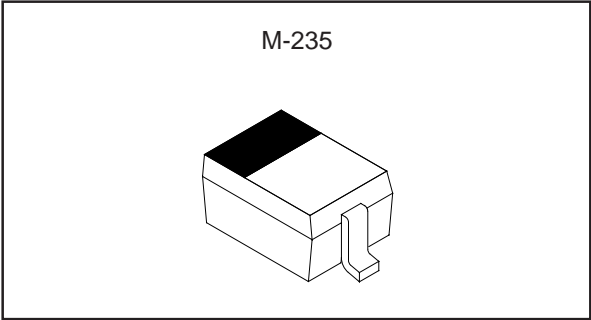

**Absolute Maximum Ratings (Ta=25 °C)**

- Reverse voltage V<sub>R</sub> 30 V
- Peak reverse voltage V<sub>RM</sub> 35 V  
(R<sub>L</sub>≥10 kΩ)
- Operating temperature Topr 85 °C
- Storage temperature Tstg -55 to +150 °C

**Electrical Characteristics**

(Ta=25 °C)

Item	Symbol	Conditions	Min.	Typ.	Max.	Unit
Reverse current	I <sub>R</sub>	V <sub>R</sub> =28 V			10	nA
Diode capacitance	C <sub>1</sub>	V <sub>R</sub> =1 V, f=1 MHz	34.65	38.00	42.35	pF
	C <sub>28</sub>	V <sub>R</sub> =28 V, f=1 MHz	2.361	2.515	2.754	pF
Capacitance ratio	C <sub>1</sub> /C <sub>28</sub>	f=1 MHz	13.5	15.0		
Series resistance	r <sub>s</sub>	C <sub>D</sub> =14 pF, f=470 MHz		0.75	0.80	Ω
Maximum-capacitance deviation in the same ranking	ΔC	V <sub>R</sub> =1 to 28 V, f=1 MHz			3	%

Sony reserves the right to change products and specifications without prior notice. This information does not convey any license by any implication or otherwise under any patents or other right. Application circuits shown, if any, are typical examples illustrating the operation of the devices. Sony cannot assume responsibility for any problems arising out of the use of these circuits.

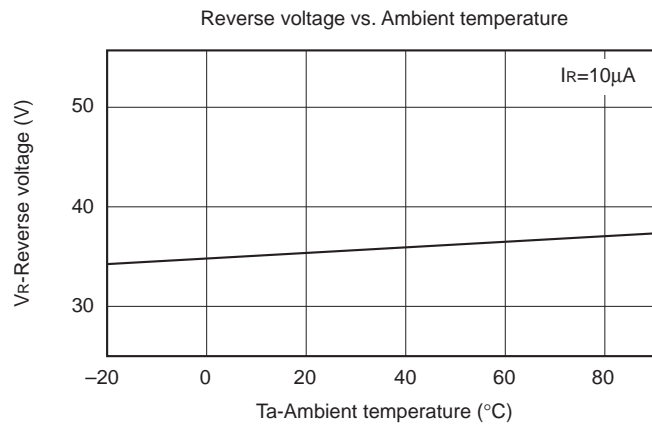
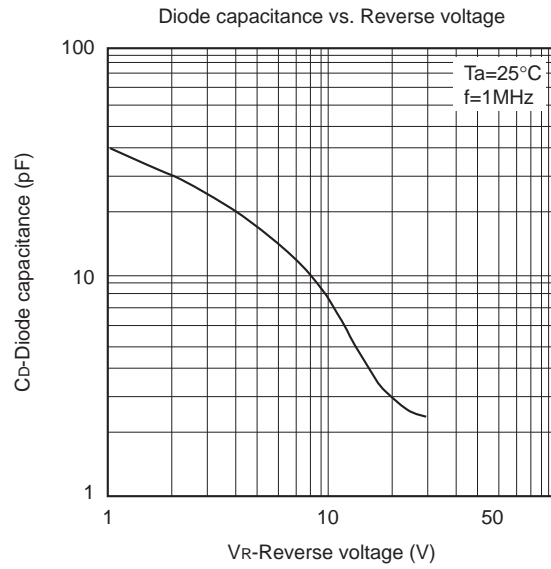

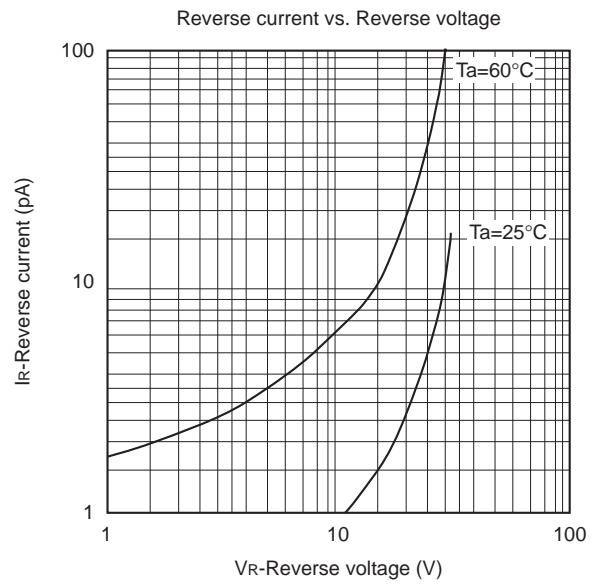
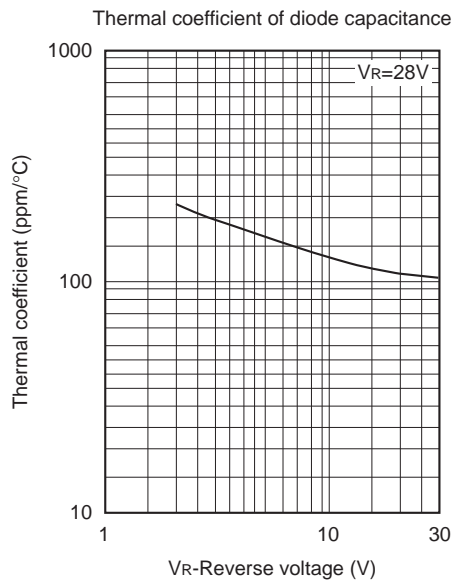
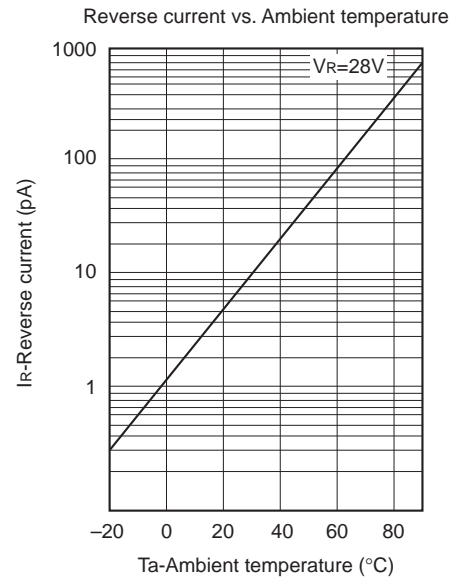
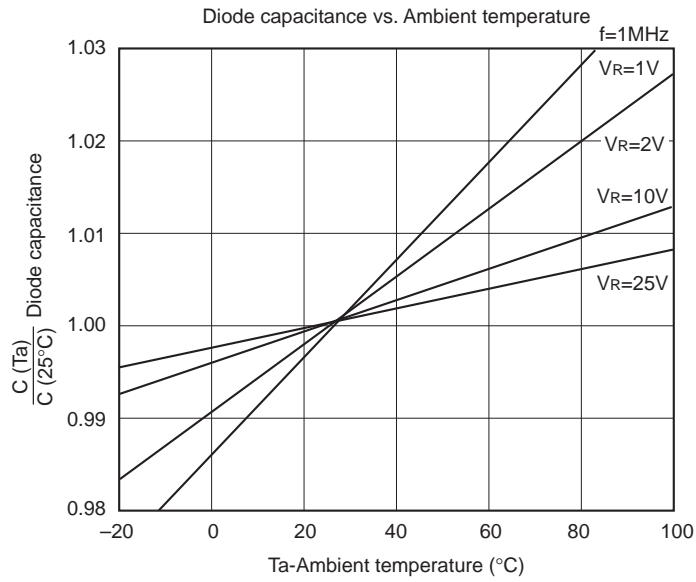

Package Outline Unit : mm

M-235

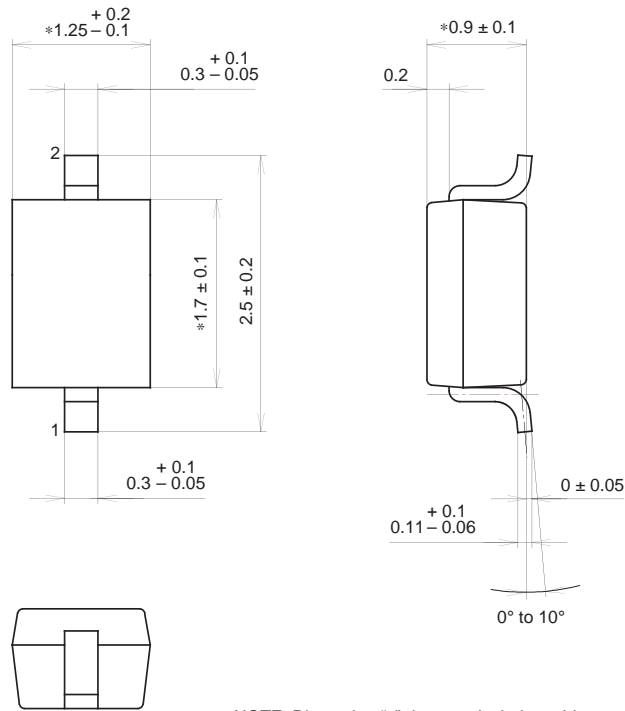

NOTE: Dimension "\*" does not include mold protrusion.

SONY CODE	M-235
EIAJ CODE	—
JEDEC CODE	—

PACKAGE WEIGHT	0.1g
----------------	------

Marking

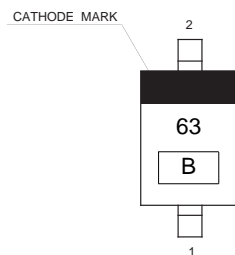

Notes

- 1) B: Lot No. (Year and Month of manufacture)  
 Year; Last one digit  
 Month; A, B, C (for Oct. to Dec.)  
 1 to 9 (for Jan. to Sept.)