

**GaAs Broadband SPDT Switch  
DC - 6.0 GHz**

**MASWSS0093  
V2**

**Features**

- UNII, Hiperlan, and 802.11a+b/g Applications
- Broadband Performance: DC-6 GHz
- Low Insertion Loss: 0.9 dB at 6 GHz
- High Isolation: 28 dB Typical
- Fast Switching Speed: 0.5  $\mu$ m GaAs PHEMT
- High Power: 36 dBm P1dB
- Lead-Free 3 mm 12-lead PQFN Package
- 100% Matte Tin Plating over Copper
- Halogen-Free "Green" Mold Compound
- RoHS\* Compliant and 260°C Reflow Compatible

**Description**

M/A-COM's MASWSS0093 is a broadband GaAs PHEMT MMIC SPDT switch in a low cost, lead-free 3 mm 12-lead PQFN package. The MASWSS0093 is ideally suited for applications where very small size and low cost are required.

The MASWSS0093, with its small size and low height, is ideal for 802.11a and 802.11b/g PC card and access point applications.

The MASWSS0093 delivers high isolation, low insertion loss and high linearity up to 6 GHz.

The MASWSS0093 is fabricated using a 0.5 micron gate length GaAs PHEMT process. The process features full passivation for performance and reliability.

**Ordering Information**

Part Number	Package
MASWSS0093	Bulk Packaging
MASWSS0093TR	1000 piece reel
MASWSS0093SMB	Sample Test Board (Includes 5 Samples)

Note: Reference Application Note M513 for reel size information.

\* Restrictions on Hazardous Substances, European Union Directive 2002/95/EC.

**Functional Schematic**

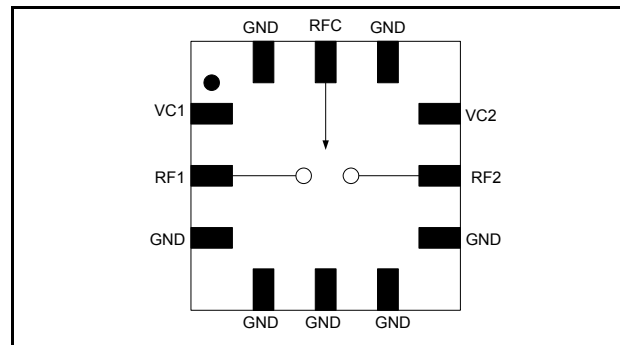

**Pin Configuration**

PIN No.	PIN Name	Description
1	VC1	Control 1
2	RF1	RF Port 1
3	GND	Ground
4	GND	Ground
5	GND	Ground
6	GND	Ground
7	GND	Ground
8	RF2	RF Port 2
9	VC2	Control 2
10	GND	Ground
11	RFC	RF Input
12	GND	Ground
13	Paddle <sup>1</sup>	RF and DC Ground

1. The exposed pad centered on the package bottom must be connected to RF and DC ground.

**Absolute Maximum Ratings<sup>2,3</sup>**

Parameter	Absolute Maximum
Input Power @ 3 V Control	+37 dBm
Input Power @ 5 V Control	+39 dBm
Operating Voltage	+8.5 volts
Operating Temperature	-40°C to +85°C
Storage Temperature	-65°C to +150°C

2. Exceeding any one or combination of these limits may cause permanent damage to this device.
3. M/A-COM does not recommend sustained operation near these survivability limits.

M/A-COM Inc. and its affiliates reserve the right to make changes to the product(s) or information contained herein without notice. M/A-COM makes no warranty, representation or guarantee regarding the suitability of its products for any particular purpose, nor does M/A-COM assume any liability whatsoever arising out of the use or application of any product(s) or information.

- **North America** Tel: 800.366.2266 / Fax: 978.366.2266
- **Europe** Tel: 44.1908.574.200 / Fax: 44.1908.574.300
- **Asia/Pacific** Tel: 81.44.844.8296 / Fax: 81.44.844.8298

Visit [www.macom.com](http://www.macom.com) for additional data sheets and product information.

**GaAs Broadband SPDT Switch  
DC - 6.0 GHz**

**MASWSS0093  
V2**

**Electrical Specifications<sup>4</sup>:  $T_A = 25^\circ\text{C}$ ,  $Z_0 = 50\Omega$ ,  $V_c = 0 \text{ V}/3 \text{ V}$ ,  $\text{Pin} = 0 \text{ dBm}$**

Parameter	Test Conditions	Units	Min.	Typ.	Max.
Insertion Loss	2.4 GHz	dB	—	0.70	1.05
	5.3 GHz	dB	—	0.85	1.2
	5.8 GHz	dB	—	0.85	1.2
Isolation	2.4 GHz	dB	24	29	—
	5.3 GHz	dB	23	28	—
	5.8 GHz	dB	21	26	—
Return Loss	DC - 6 GHz	dB	—	20	—
IP2	Two Tone, +15 dBm/Tone, 5 MHz Spacing, >50 MHz				
	2.4 GHz, $V_c = 3.0 \text{ V}$	dBm	—	98	—
	5.8 GHz, $V_c = 3.0 \text{ V}$	dBm	—	81	—
	2.4 GHz, $V_c = 5.0 \text{ V}$	dBm	—	107	—
IIP3	Two Tone, +15 dBm/Tone, 5 MHz Spacing, >50 MHz				
	2.4 GHz, $V_c = 3.0 \text{ V}$	dBm	—	57	—
	5.8 GHz, $V_c = 3.0 \text{ V}$	dBm	—	53	—
	2.4 GHz, $V_c = 5.0 \text{ V}$	dBm	—	57	—
Input P-1dB	2.4 GHz	dBm	—	40	—
	5.3 GHz	dBm	—	36	—
	5.8 GHz	dBm	—	37	—
2nd Harmonic	2.4 GHz, $\text{Pin} = +20 \text{ dBm}$	dBm	—	-72	—
	5.8 GHz, $\text{Pin} = +20 \text{ dBm}$	dBm	—	-69	—
3rd Harmonic	2.4 GHz, $\text{Pin} = +20 \text{ dBm}$	dBm	—	-85	—
	5.8 GHz, $\text{Pin} = +20 \text{ dBm}$	dBm	—	-75	—
T-rise, T-fall	10% to 90% RF and 90% to 10% RF	nS	—	55	—
Ton, Toff	50% control to 90% RF, and 50% control to 10% RF	nS	—	80	—
Transients	—	mV	—	14	—
Control Current	$ V_c  = 3 \text{ V}$	$\mu\text{A}$	—	15	25

**Truth Table<sup>4,5,6</sup>**

Control V1	Control V2	RFC—RF1	RFC—RF2
1	0	On	Off
0	1	Off	On

- For positive voltage control, external DC blocking capacitors are required on all RF ports.
- Differential voltage,  $V(\text{state } 1) - V(\text{state } 0)$ , must be +2.7 V minimum and must not exceed +5 V.
- $0 = 0 \pm 0.2 \text{ V}$ ,  $1 = +2.9 \text{ V to } +5 \text{ V}$ .

**Handling Procedures**

Please observe the following precautions to avoid damage:

**Static Sensitivity**

Gallium Arsenide Integrated Circuits are sensitive to electrostatic discharge (ESD) and can be damaged by static electricity. Proper ESD control techniques should be used when handling these devices.

**GaAs Broadband SPDT Switch  
DC - 6.0 GHz**

**MASWSS0093  
V2**

**Typical Performance Curves**

**Insertion Loss**

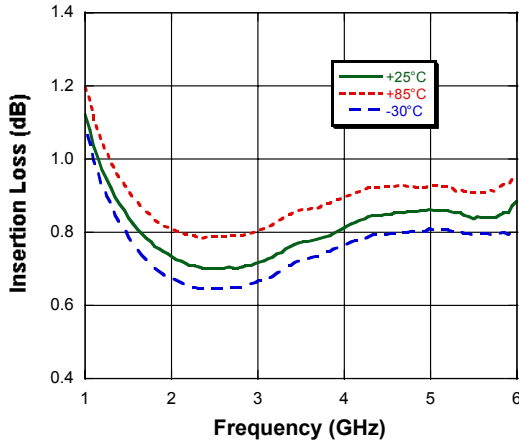

**Isolation**

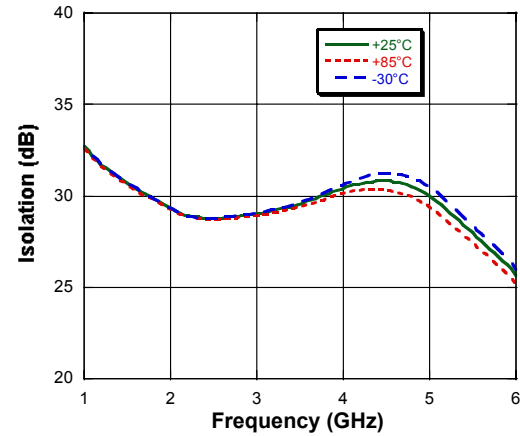

**Return Loss**

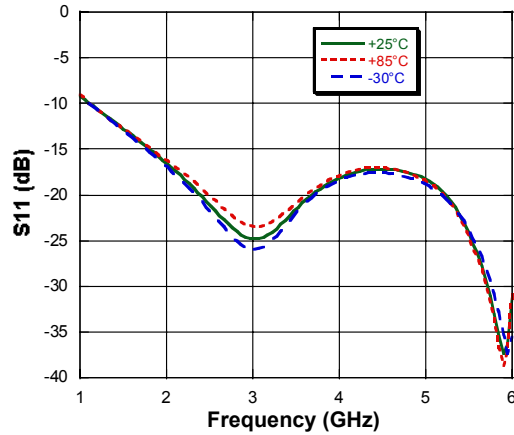

**Application Schematic**

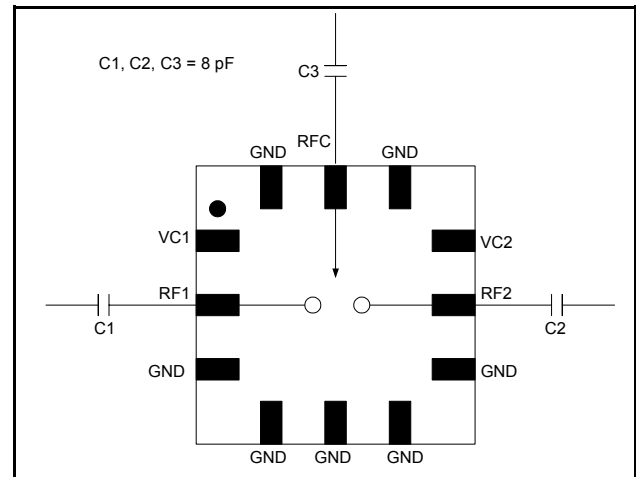

**Lead-Free 3 mm 12-lead PQFN†**

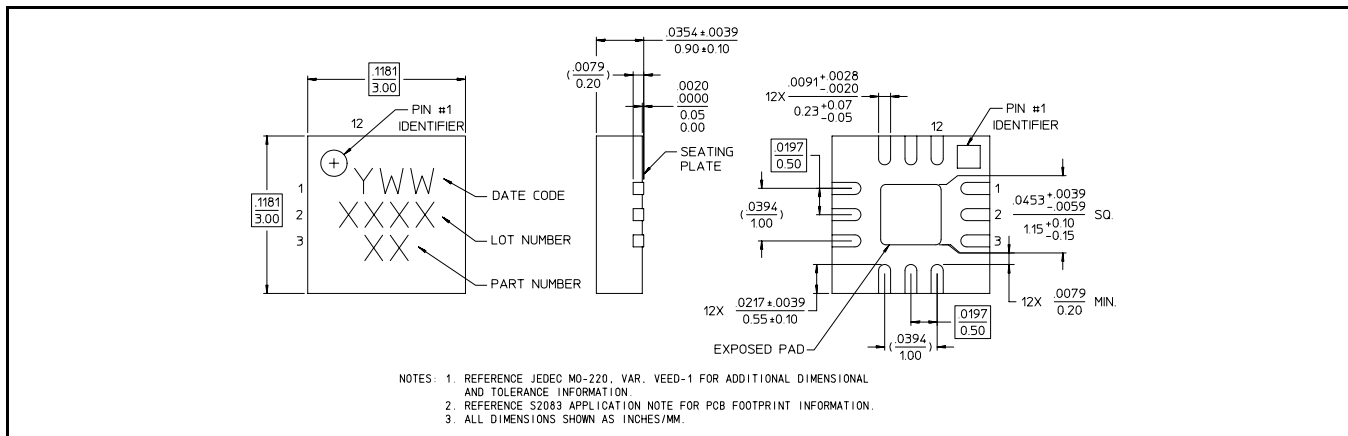

† Reference Application Note M538 for lead-free solder reflow recommendations.