

Smart Highside Power Switch

Features

- Load dump and reverse battery protection¹⁾
- Clamp of negative voltage at output
- Short-circuit protection
- Current limitation
- Thermal shutdown
- Diagnostic feedback
- Open load detection in ON-state
- CMOS compatible input
- **Electrostatic discharge (ESD) protection**
- Loss of ground and loss of V_{bb} protection²⁾
- Overvoltage protection
- Undervoltage and overvoltage shutdown with auto-restart and hysteresis

Application

- μ C compatible power switch with diagnostic feedback for 12 V and 24 V DC grounded loads
- All types of resistive, inductive and capacitive loads
- Replaces electromechanical relays and discrete circuits

Product Summary

$V_{Load\ dump}$	80	V
$V_{bb} - V_{OUT}$ Avalanche Clamp	58	V
V_{bb} (operation)	4.5 ... 42	V
V_{bb} (reverse)	-32	V
R_{ON}	38	m Ω
$I_L(SCp)$	44	A
$I_L(SCr)$	35	A
$I_L(ISO)$	11	A

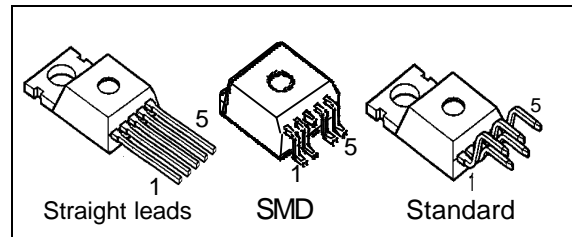

General Description

N channel vertical power FET with charge pump, ground referenced CMOS compatible input and diagnostic feedback, integrated in Smart SIPMOS[®] chip on chip technology. Fully protected by embedded protection functions.

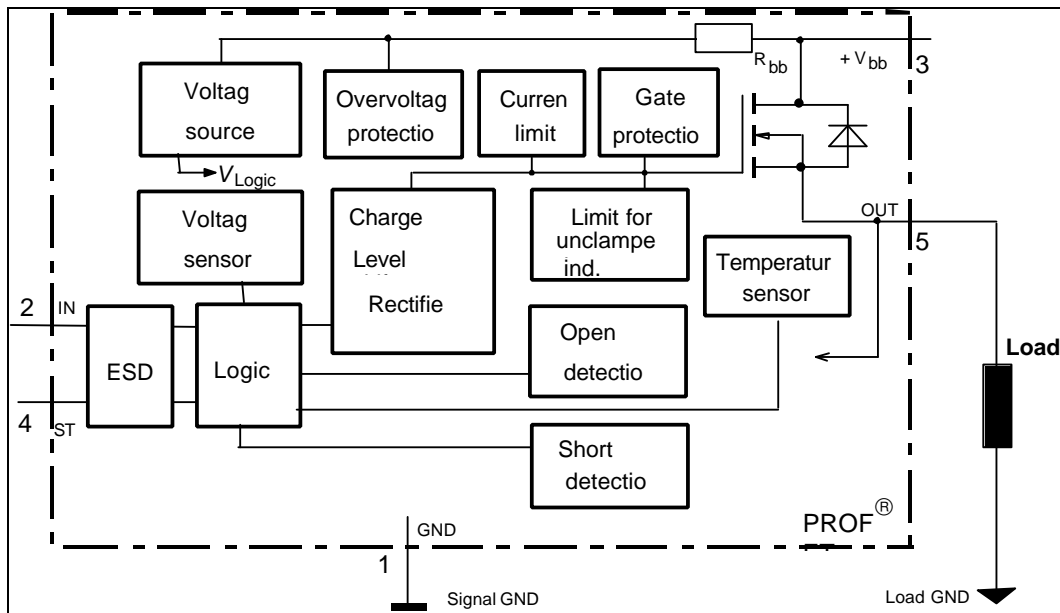

1) No external components required, reverse load current limited by connected load.

2) Additional external diode required for charged inductive loads

Pin	Symbol		Function
1	GND	-	Logic ground
2	IN	I	Input, activates the power switch in case of logical high signal
3	V _{bb}	+	Positive power supply voltage, the tab is shorted to this pin
4	ST	S	Diagnostic feedback, low on failure
5	OUT (Load, L)	O	Output to the load

Maximum Ratings at $T_j = 25\text{ °C}$ unless otherwise specified

Parameter	Symbol	Values	Unit	
Supply voltage (overvoltage protection see page 3)	V_{bb}	63	V	
Load dump protection $V_{LoadDump} = U_A + V_S$, $U_A = 13.5\text{ V}$ $R_I = 2\ \Omega$, $R_L = 1.1\ \Omega$, $t_d = 200\text{ ms}$, IN= low or high	$V_S^{3)}$	66.5	V	
Load current (Short-circuit current, see page 4)	I_L	self-limited	A	
Operating temperature range	T_j	-40 ... +150	°C	
Storage temperature range	T_{stg}	-55 ... +150		
Power dissipation (DC)	P_{tot}	125	W	
Inductive load switch-off energy dissipation, single pulse $T_j = 150\text{ °C}$:	E_{AS}	1.7	J	
Electrostatic discharge capability (ESD) (Human Body Model)	V_{ESD}	2.0	kV	
Input voltage (DC)	V_{IN}	-0.5 ... +6	V	
Current through input pin (DC)	I_{IN}	± 5.0	mA	
Current through status pin (DC)	I_{ST}	± 5.0		
see internal circuit diagrams page 6...				
Thermal resistance	chip - case: junction - ambient (free air): SMD version, device on pcb ⁴⁾ :	R_{thJC} R_{thJA}	≤ 1 ≤ 75 $\leq tbd$	K/W

³⁾ V_S is setup without DUT connected to the generator per ISO 7637-1 and DIN 40839

⁴⁾ Device on 50mm*50mm*1.5mm epoxy PCB FR4 with 6cm² (one layer, 70µm thick) copper area for V_{bb} connection. PCB is vertical without blown air.

Electrical Characteristics

Parameter and Conditions at $T_j = 25^\circ\text{C}$, $V_{bb} = 12\text{ V}$ unless otherwise specified	Symbol	Values			Unit
		min	typ	max	

Load Switching Capabilities and Characteristics

On-state resistance (pin 3 to 5) $I_L = 2\text{ A}$	$T_j = 25^\circ\text{C}$: $T_j = 150^\circ\text{C}$:	R_{ON}	--	30 55	38 70	$\text{m}\Omega$
Nominal load current (pin 3 to 5) ISO Proposal: $V_{ON} = 0.5\text{ V}$, $T_C = 85^\circ\text{C}$		$I_{L(ISO)}$	9	11	--	A
Output current (pin 5) while GND disconnected or GND pulled up, $V_{IN} = 0$, see diagram page 7, $T_j = -40\dots+150^\circ\text{C}$		$I_{L(GNDhigh)}$	--	--	1	mA
Turn-on time to 90% V_{OUT} :	t_{on}	50	160	300	μs	
Turn-off time to 10% V_{OUT} :	t_{off}	10	--	80		
$R_L = 12\ \Omega$, $T_j = -40\dots+150^\circ\text{C}$						
Slew rate on 10 to 30% V_{OUT} , $R_L = 12\ \Omega$, $T_j = -40\dots+150^\circ\text{C}$	dV/dt_{on}	0.4	--	2.5	$\text{V}/\mu\text{s}$	
Slew rate off 70 to 40% V_{OUT} , $R_L = 12\ \Omega$, $T_j = -40\dots+150^\circ\text{C}$	$-dV/dt_{off}$	1	--	5	$\text{V}/\mu\text{s}$	

Operating Parameters

Operating voltage ⁵⁾	$T_j = -40\dots+150^\circ\text{C}$:	$V_{bb(on)}$	4.5	--	42	V
Undervoltage shutdown	$T_j = -40\dots+150^\circ\text{C}$:	$V_{bb(under)}$	2.4	--	4.5	V
Undervoltage restart	$T_j = -40\dots+150^\circ\text{C}$:	$V_{bb(u\ rst)}$	--	--	4.5	V
Undervoltage restart of charge pump see diagram page 12	$T_j = -40\dots+150^\circ\text{C}$:	$V_{bb(ucp)}$	--	6.5	7.5	V
Undervoltage hysteresis $\Delta V_{bb(under)} = V_{bb(u\ rst)} - V_{bb(under)}$		$\Delta V_{bb(under)}$	--	0.2	--	V
Overvoltage shutdown	$T_j = -40\dots+150^\circ\text{C}$:	$V_{bb(over)}$	42	--	52	V
Overvoltage restart	$T_j = -40\dots+150^\circ\text{C}$:	$V_{bb(o\ rst)}$	42	--	--	V
Overvoltage hysteresis	$T_j = -40\dots+150^\circ\text{C}$:	$\Delta V_{bb(over)}$	--	0.2	--	V
Overvoltage protection ⁶⁾	$T_j = -40^\circ\text{C}$:	$V_{bb(AZ)}$	60	--	--	V
$I_{bb} = 40\text{ mA}$	$T_j = 25\dots+150^\circ\text{C}$:		63	67		
Standby current (pin 3) $V_{IN} = 0$, $I_{ST} = 0$,	$T_j = -40\dots+25^\circ\text{C}$:	$I_{bb(off)}$	--	12	25	μA
	$T_j = 150^\circ\text{C}$:		--	18	60	
Leakage output current (included in $I_{bb(off)}$) $V_{IN} = 0$		$I_{L(off)}$	--	6	--	μA
Operating current (Pin 1) ⁷⁾ , $V_{IN} = 5\text{ V}$		I_{GND}	--	1.1	--	mA

⁵⁾ At supply voltage increase up to $V_{bb} = 6.5\text{ V}$ typ without charge pump, $V_{OUT} \approx V_{bb} - 2\text{ V}$

⁶⁾ see also $V_{ON(CL)}$ in table of protection functions and circuit diagram page 7. Measured without load.

Protection Functions

Initial peak short circuit current limit (pin 3 to 5) ⁸⁾ , (max 400 μ s if $V_{ON} > V_{ON(SC)}$)	$I_{L(SCp)}$					
$T_j = -40^\circ\text{C}$:		--	--	74	A	
$T_j = 25^\circ\text{C}$:		--	44	--		
$T_j = +150^\circ\text{C}$:		24	--	--		
Repetitive short circuit current limit $T_j = T_{jt}$ (see timing diagrams, page 10)	$I_{L(SCr)}$	22	35	--	A	
Short circuit shutdown delay after input pos. slope $V_{ON} > V_{ON(SC)}$, min value valid only, if input "low" time exceeds 30 μ s	$t_d(SC)$	80	--	400	μ s	
Output clamp (inductive load switch off) at $V_{OUT} = V_{bb} - V_{ON(CL)}$, $I_L = 30$ mA	$V_{ON(CL)}$	--	58	--	V	
Short circuit shutdown detection voltage (pin 3 to 5)	$V_{ON(SC)}$	--	8.3	--	V	
Thermal overload trip temperature	T_{jt}	150	--	--	$^\circ\text{C}$	
Thermal hysteresis	DT_{jt}	--	10	--	K	
Inductive load switch-off energy dissipation ⁹⁾ , $T_{j \text{ Start}} = 150^\circ\text{C}$, single pulse	E_{AS}	--	--	1.7	J	
$V_{bb} = 12$ V:	E_{Load12}			1.3		
$V_{bb} = 24$ V:	E_{Load24}			1.0		
Reverse battery (pin 3 to 1) ¹⁰⁾	$-V_{bb}$	--	--	32	V	
Integrated resistor in V_{bb} line	R_{bb}	--	120	--	Ω	

Diagnostic Characteristics

Open load detection current (on-condition)	$I_{L(OL)}$					
$T_j = -40^\circ\text{C}$:		2	--	900	mA	
$T_j = 25..150^\circ\text{C}$:		2	--	750		

7) Add I_{ST} , if $I_{ST} > 0$, add I_{IN} , if $V_{IN} > 5.5$ V



8) Short circuit current limit for max. duration of 400 μ s, prior to shutdown (see $t_d(SC)$ page 4)

9) While demagnetizing load inductance, dissipated energy in PROFET is $E_{AS} = \int V_{ON(CL)} * I_L(t) dt$, approx.

$$E_{AS} = \frac{1}{2} * L * I_L^2 * \left(\frac{V_{ON(CL)}}{V_{ON(CL)} - V_{bb}} \right), \text{ see diagram page 8}$$

10) Reverse load current (through intrinsic drain-source diode) is normally limited by the connected load. Reverse current I_{GND} of ≈ 0.3 A at $V_{bb} = -32$ V through the logic heats up the device. Time allowed under these condition is dependent on the size of the heatsink. Reverse I_{GND} can be reduced by an additional external GND-resistor (150 Ω). Input and Status currents have to be limited (see max. ratings page 2 and circuit page 7).

Input and Status Feedback¹¹⁾

Input turn-on threshold voltage		$V_{IN(T+)}$	1.5	--	2.4	V
	$T_j = -40..+150^\circ\text{C}$:					
Input turn-off threshold voltage		$V_{IN(T-)}$	1.0	--	--	V
	$T_j = -40..+150^\circ\text{C}$:					
Input threshold hysteresis		$\Delta V_{IN(T)}$	--	0.5	--	V
Off state input current (pin 2)	$V_{IN} = 0.4 \text{ V}$:	$I_{IN(off)}$	1	--	30	μA
On state input current (pin 2)	$V_{IN} = 3.5 \text{ V}$:	$I_{IN(on)}$	10	25	50	μA
Status invalid after positive input slope (short circuit)	$T_j = -40 \dots +150^\circ\text{C}$:	$t_{d(ST \text{ SC})}$	80	200	400	μs
Status invalid after positive input slope (open load)	$T_j = -40 \dots +150^\circ\text{C}$:	$t_{d(ST)}$	350	--	1600	μs
Status output (CMOS)	$T_j = -40\dots+150^\circ\text{C}$, $I_{ST} = -50 \mu\text{A}$:	$V_{ST(high)}^{12)}$	4.4	5.1	6.5	V
	$T_j = -40\dots+150^\circ\text{C}$, $I_{ST} = +1.6 \text{ mA}$:	$V_{ST(low)}$	--	--	0.4	
Max. status current for valid status output, $T_j = -40\dots+150^\circ\text{C}$	current source (out):	$-I_{ST}$	--	--	0.25	mA
	current sink (in) :	$+I_{ST}^{13)}$	--	--	1.6	

11) If a ground resistor R_{GND} is used, add the voltage drop across this resistor.

12) $V_{St \text{ high}} \approx V_{bb}$ during undervoltage shutdown

13) No current sink capability during undervoltage shutdown

Truth Table

	Input-level	Output level	Status		
			432 D2	432 E2/F2	432 I2
Normal operation	L	L	H	H	H
	H	H	H	H	H
Open load	L	14)	H	H	L
	H	H	L	L	H
Short circuit to GND	L	L	H	H	H
	H	L	L	L	L
Short circuit to V_{bb}	L	H	H	H	L
	H	H	H (L ¹⁵)	H (L ¹⁵)	H
Overtemperature	L	L	L	L	L
	H	L	L	L	L
Undervoltage	L	L	L ¹⁶	H	L ¹⁶
	H	L	L ¹⁶	H	L ¹⁶
Overvoltage	L	L	L	H	L
	H	L	L	H	L

L = "Low" Level
H = "High" Level

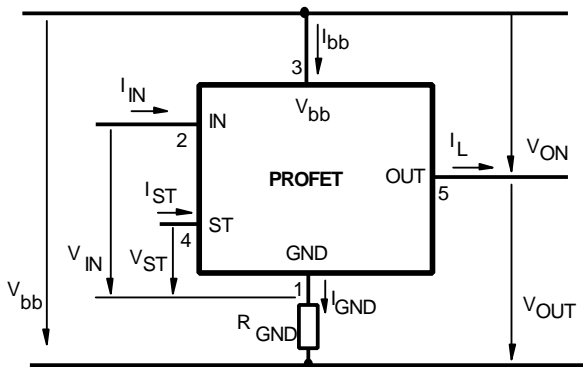
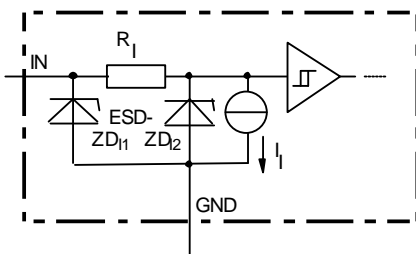
Terms

Input circuit (ESD protection)

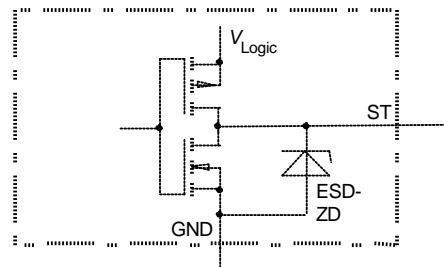
ZD1 6.1 V typ., ESD zener diodes are not designed for continuous current

Status output

Zener diode: 6.1 V typ., max 5 mA, V_{Logic} 5 V typ, ESD zener diodes are not designed for continuous current

Short Circuit detection

Fault Condition: $V_{ON} > 8.3$ V typ.; IN high

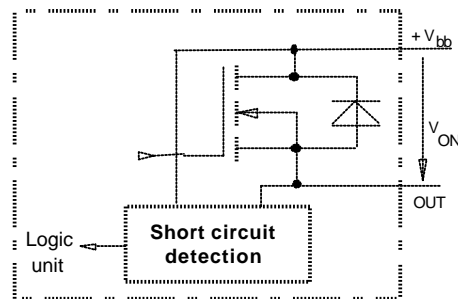

- 14) Power Transistor off, high impedance
- 15) Low resistance short V_{bb} to output may be detected by no-load-detection
- 16) No current sink capability during undervoltage shutdown

Inductive and overvoltage output clamp

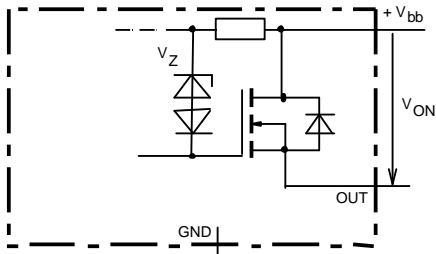

V_{ON} clamped to 58 V typ.

Overvolt. and reverse batt. protection

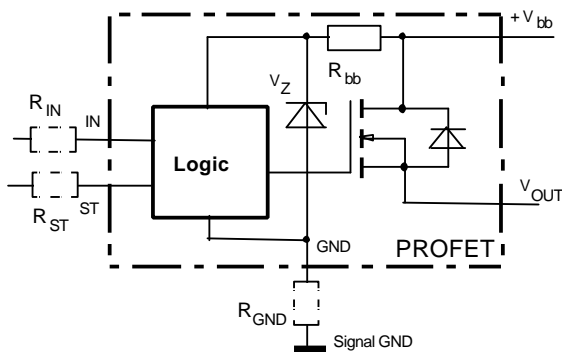

$R_{bb} = 120 \Omega$ typ., $V_Z + R_{bb} * 40 \text{ mA} = 67 \text{ V}$ typ., add R_{GND} , R_{IN} , R_{ST} for extended protection

Open-load detection

ON-state diagnostic condition: $V_{ON} < R_{ON} * I_{L(OL)}$; IN high

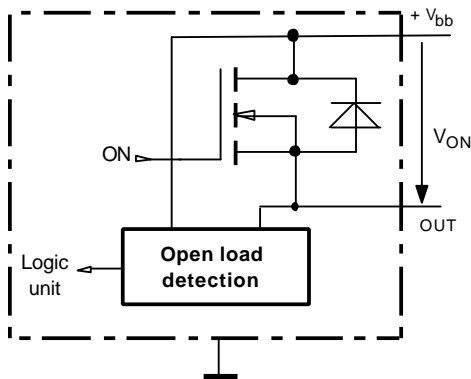

GND disconnect

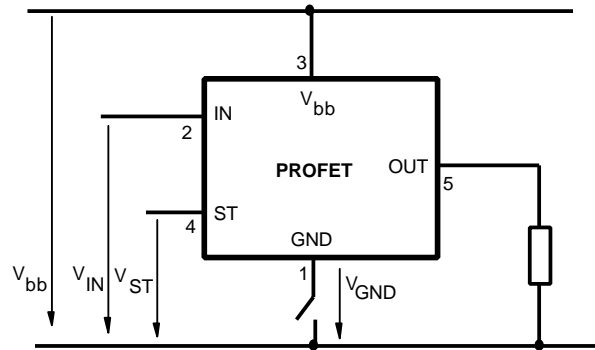

Any kind of load. In case of Input=high is $V_{OUT} \approx V_{IN} - V_{IN(T+)}$. Due to $V_{GND} > 0$, no $V_{ST} = \text{low}$ signal available.

GND disconnect with GND pull up

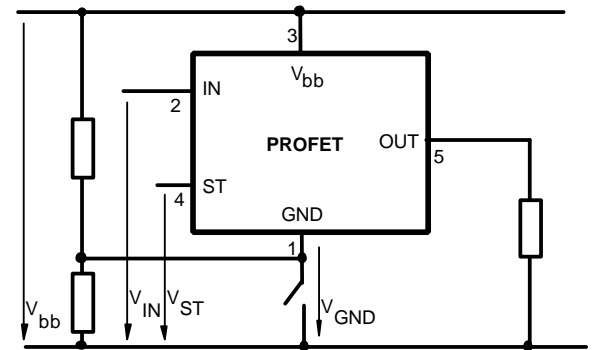

Any kind of load. If $V_{GND} > V_{IN} - V_{IN(T+)}$ device stays off Due to $V_{GND} > 0$, no $V_{ST} = \text{low}$ signal available.

Vbb disconnect with charged inductive load

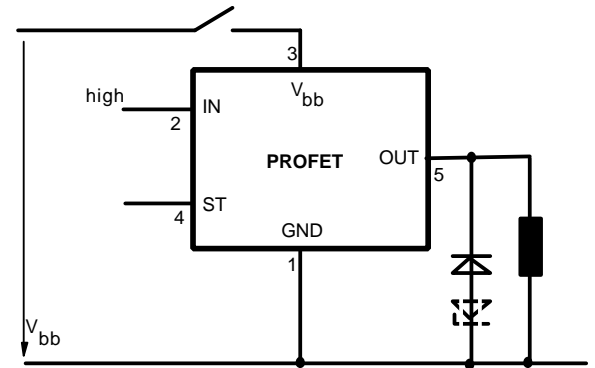

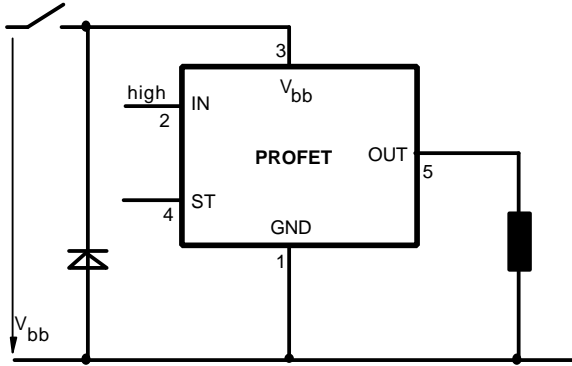

Inductive Load switch-off energy dissipation

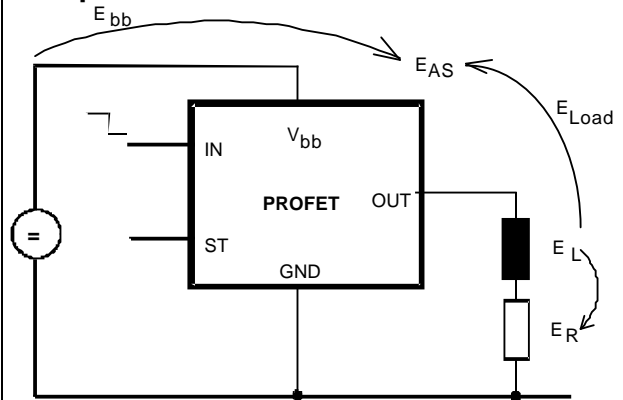

Energy dissipated in PROFET $E_{AS} = E_{bb} + E_L - E_R$.
 $E_{Load} < E_L$, $E_L = \frac{1}{2} * L * I_L^2$

Options Overview

all versions: High-side switch, Input protection, ESD protection, load dump and reverse battery protection , protection against loss of ground

Type	BTS	432D2	432E2	432F2	432I2
Logic version		D	E	F	I
Overtemperature protection					
$T_j > 150\text{ °C}$, latch function ¹⁷⁾¹⁸⁾		X		X	X
$T_j > 150\text{ °C}$, with auto-restart on cooling			X		
Short-circuit to GND protection					
switches off when $V_{ON} > 8.3\text{ V typ.}$ ¹⁷⁾ (when first turned on after approx. 200 μs)		X	X	X	X
Open load detection					
in OFF-state with sensing current 30 $\mu\text{A typ.}$ in ON-state with sensing voltage drop across power transistor		X	X	X	X
Undervoltage shutdown with auto restart		X	X	X	X
Overvoltage shutdown with auto restart		X	X	X	X
Status feedback for					
overtemperature		X	X	X	X
short circuit to GND		X	X	X	X
short to V_{bb}		-19)	-19)	-19)	X
open load		X	X	X	X
undervoltage		X	-	-	X
overvoltage		X	-	-	X
Status output type					
CMOS		X			X
Open drain			X	X	
Output negative voltage transient limit (fast inductive load switch off)					
to $V_{bb} - V_{ON(CL)}$		X	X	X	X
Load current limit					
high level (can handle loads with high inrush currents)		X	X		
medium level					X
low level (better protection of application)				X	

17) Latch except when $V_{bb} - V_{OUT} < V_{ON(SC)}$ after shutdown. In most cases $V_{OUT} = 0\text{ V}$ after shutdown ($V_{OUT} \neq 0\text{ V}$ only if forced externally). So the device remains latched unless $V_{bb} < V_{ON(SC)}$ (see page 4). No latch between turn on and $t_d(SC)$.

18) With latch function. Reseted by a) Input low, b) Undervoltage, c) Overvoltage

19) Low resistance short V_{bb} to output may be detected by no-load-detection

Timing diagrams

Figure 1a: V_{bb} turn on:

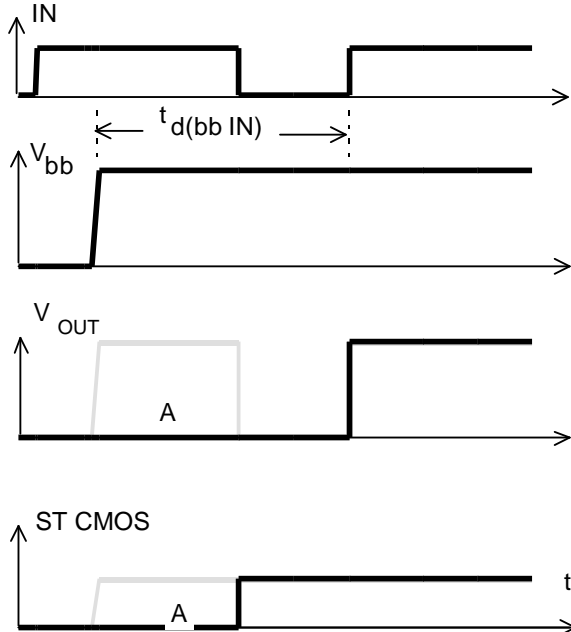

in case of too early V_{IN} =high the device may not turn on (curve A)
 $t_{d(bb IN)}$ approx. 150 μ s

Figure 2a: Switching a lamp,

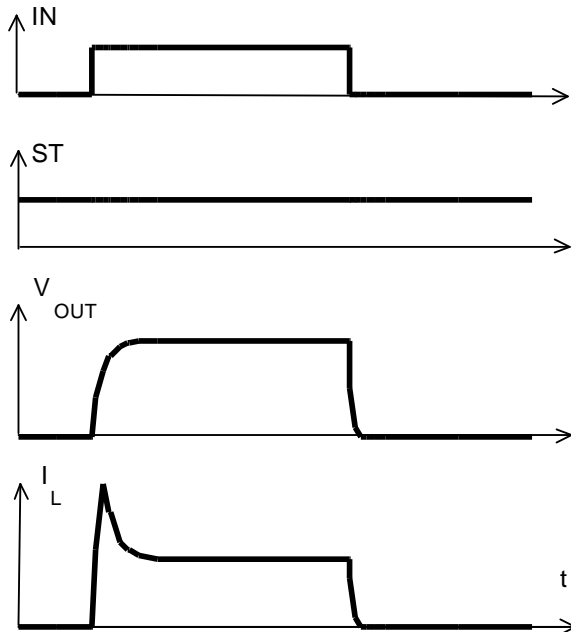
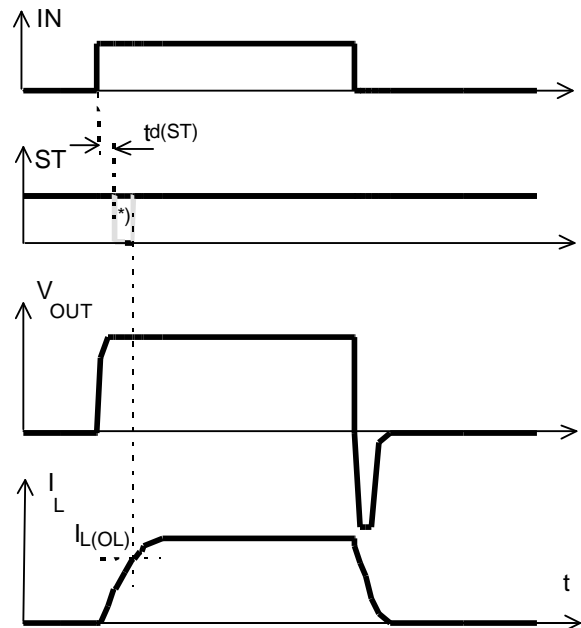
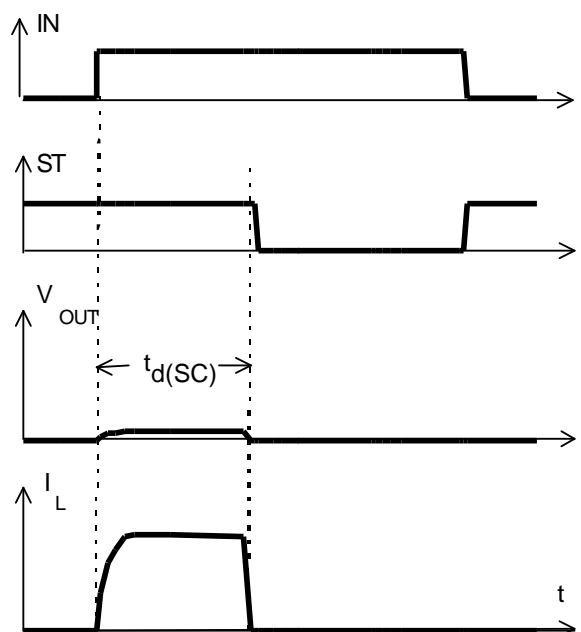

Figure 2b: Switching an inductive load



*) if the time constant of load is too large, open-load-status may occur

Figure 3a: Turn on into short circuit,



$t_{d(SC)}$ approx. 200 μ s if $V_{bb} - V_{OUT} > 8.3$ V typ.

Figure 3b: Turn on into overload,

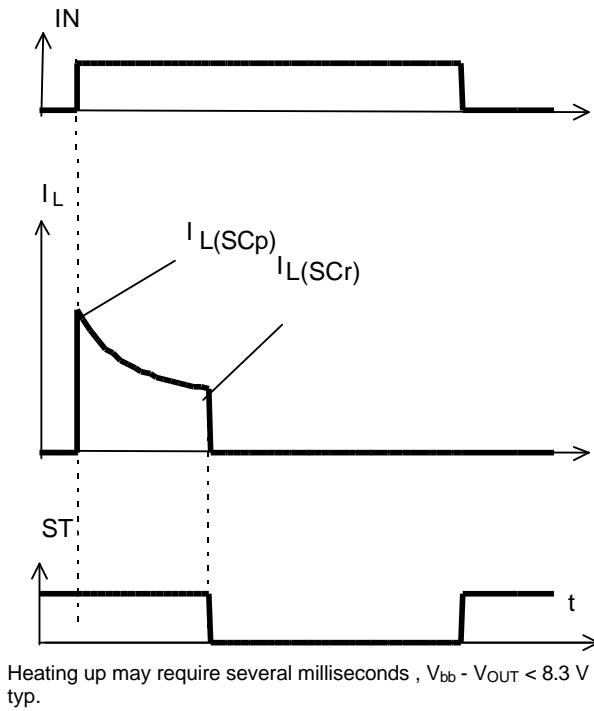

Figure 3c: Short circuit while on:

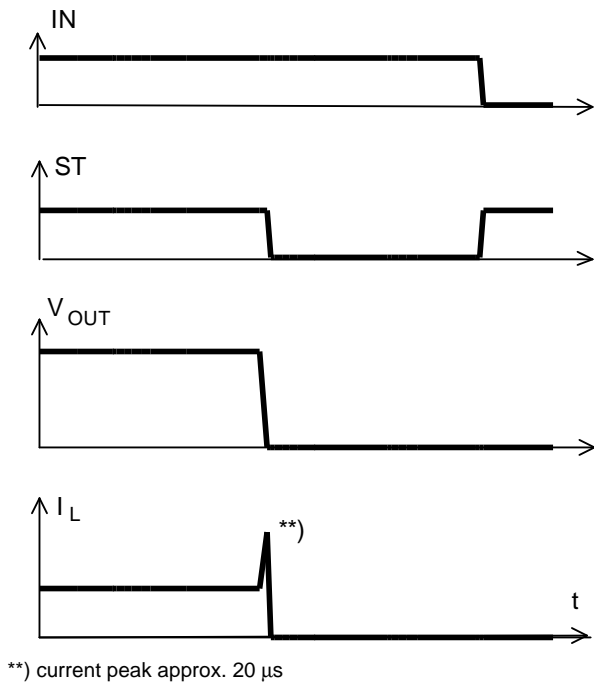
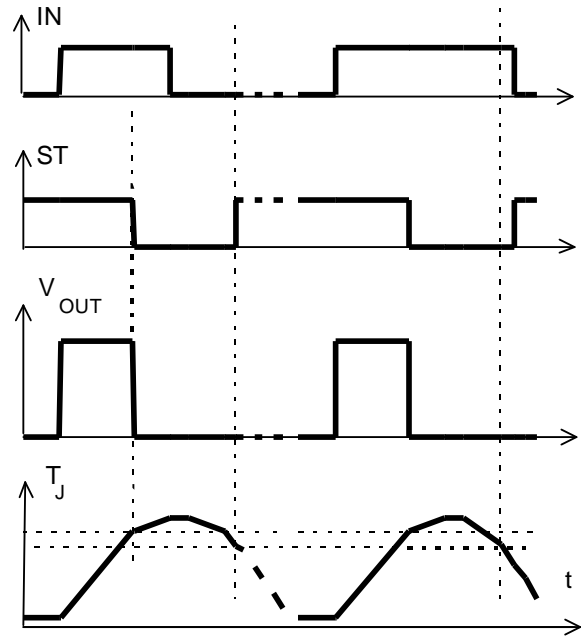

Figure 4a: Overtemperature,

Reset if (IN=low) and ($T_j < T_{jt}$)



*) ST goes high, when V_{IN} =low and $T_j < T_{jt}$

Figure 5a: Open load: detection in ON-state, turn on/off to open load

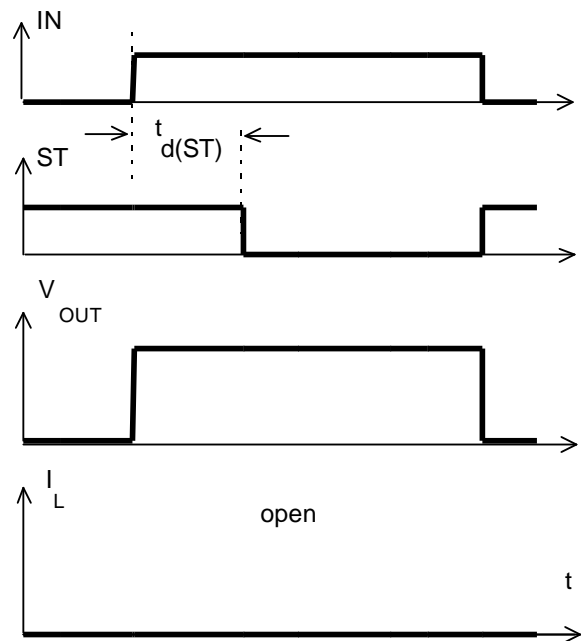

Figure 5b: Open load: detection in ON-state, open load occurs in on-state

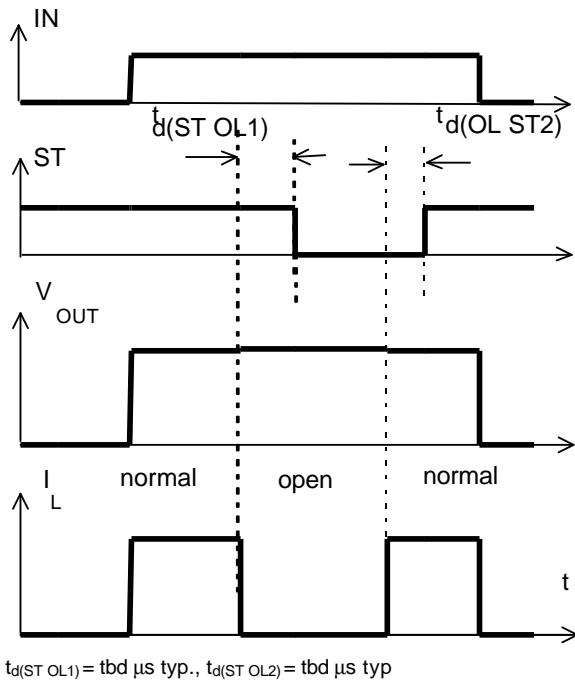

Figure 6a: Undervoltage:

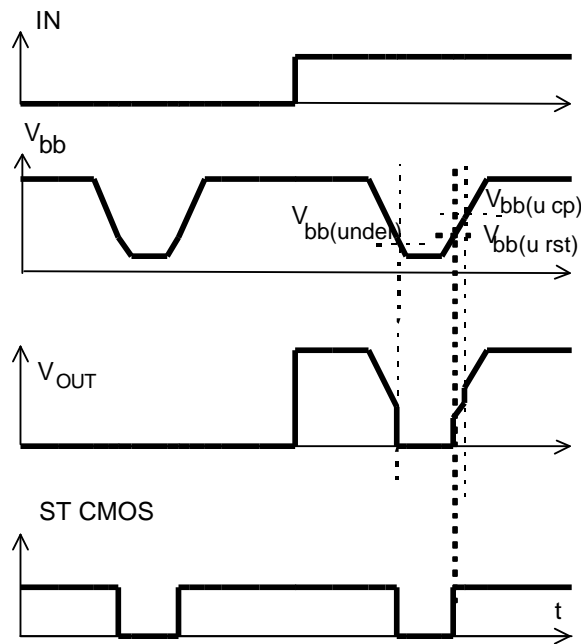

Figure 6b: Undervoltage restart of charge pump

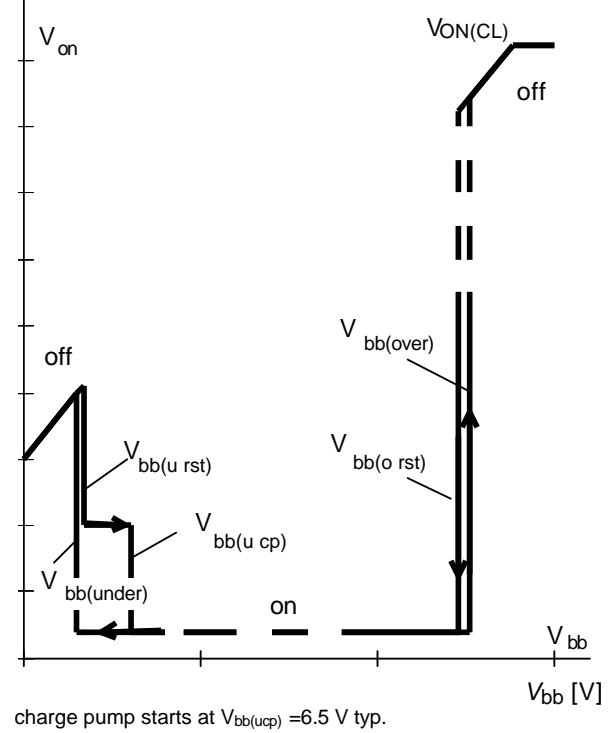
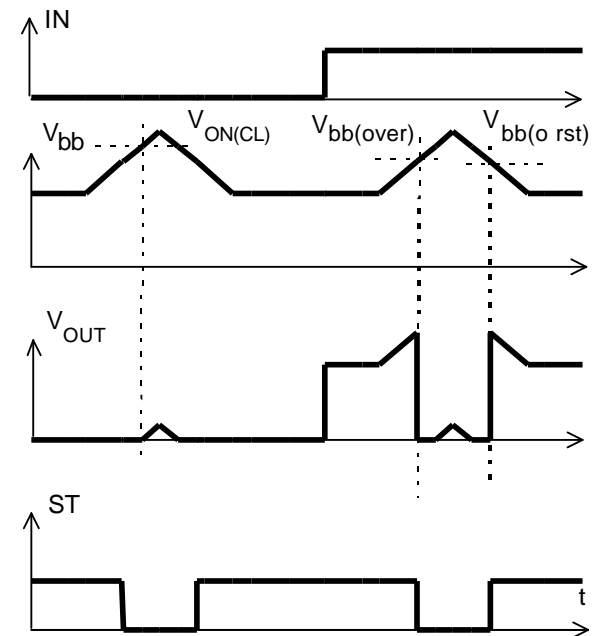

Figure 7a: Overvoltage:



Published by Infineon Technologies AG, Balanstraße 73, D-81541 München

© Infineon Technologies AG 2002. All Rights Reserved

Attention please!

As far as patents or other rights of third parties are concerned, liability is only assumed for components, not for applications, processes and circuits implemented within components or assemblies. The information describes a type of component and shall not be considered as warranted characteristics. Terms of delivery and rights to change design reserved. For questions on technology, delivery and prices please contact the Semiconductor Group Offices in Germany or the Infineon Companies and Representatives worldwide (see address list). Due to technical requirements components may contain dangerous substances. For information on the types in question please contact your nearest Infineon Office. Infineon Technologies AG is an approved CECC manufacturer.

Packing: Please use the recycling operators known to you. We can also help you - get in touch with your nearest sales office. By agreement we will take packing material back, if it is sorted. You must bear the costs of transport. For packing material that is returned to us unsorted or which we are not obliged to accept, we shall have to invoice you for any costs incurred.

Components used in life-support devices or systems must be expressly authorised for such purpose! Critical components²⁰⁾ of the Infineon Technologies AG, may only be used in life supporting devices or systems²¹⁾ with the express written approval of Infineon Technologies AG.

20) A critical component is a component used in a life-support device or system whose failure can reasonably be expected to cause the failure of that life-support device or system, or to affect its safety or effectiveness of that device or system.

21) Life support devices or systems are intended (a) to be implanted in the human body or (b) support and/or maintain and sustain and/or protect human life. If they fail, it is reasonably to assume that the health of the user or other persons may be endangered.