

Overview

Features

- Output current ± 4 A (peak 5 A)
- Inhibit with very low quiescent current (typ. 20 μ A)
- I/O error diagnostics
- Short-circuit proof
- Four-quadrant operation
- Integrated free-wheeling diodes
- Wide temperature range

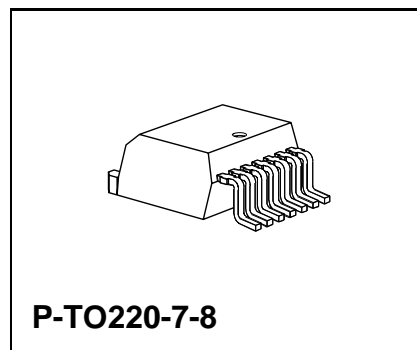
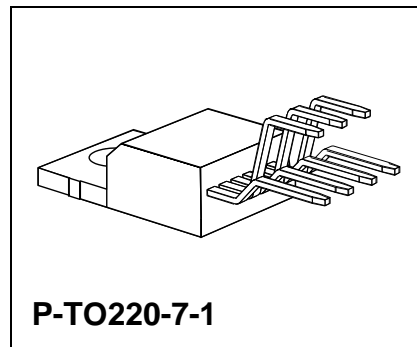

| Type | Ordering Code | Package |
|-----------|---------------|-------------|
| TLE 5207 | Q67000-A9295 | P-TO220-7-1 |
| TLE 5207G | Q67006-A9296 | P-TO220-7-8 |

Description

TLE 5207 is an integrated power bridge with inhibit feature and DMOS output stages for driving DC motors.

This motor bridge is optimized for driving DC motors in reversible operation. The internal protective circuitry in particular ensures that no crossover currents can occur.

Because the free-wheeling diodes are integrated, the external circuitry that is necessary is restricted to the capacitors on the supply voltage.

The two control inputs have TTL/CMOS-compatible levels.

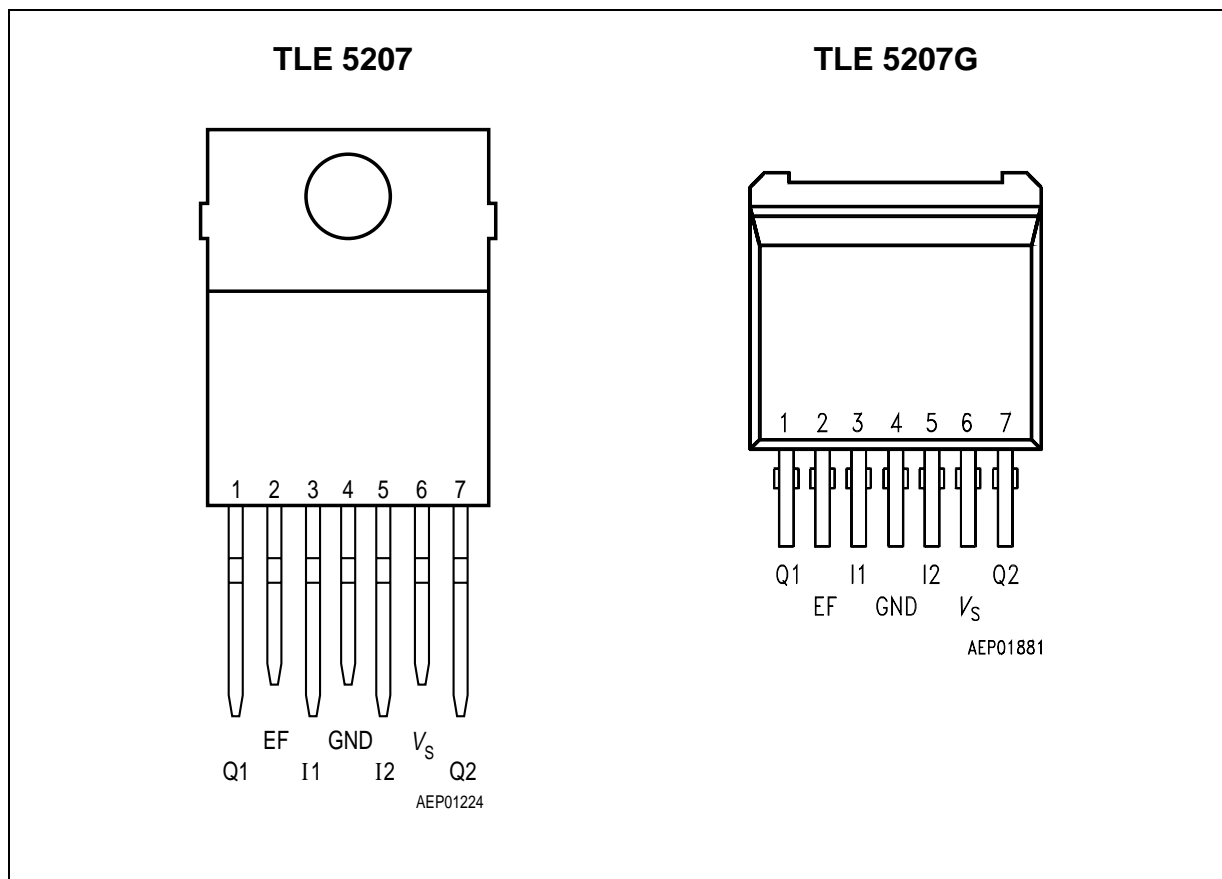

Figure 1 Pin Configuration (top view)

Pin Definitions and Functions

| Pin | Symbol | Function |
|-----|----------------|--|
| 1 | Q1 | Output of channel 1; short-circuit proof, free-wheeling diodes integrated for inductive loads |
| 2 | EF | Error flag; TTL/CMOS-compatible output for error detection (open drain) |
| 3 | I1 | Control input 1; TTL/CMOS-compatible |
| 4 | GND | Ground; connected internally to cooling fin |
| 5 | I2 | Control input 2; TTL/CMOS-compatible |
| 6 | V _S | Supply voltage; wire with capacitor matching load |
| 7 | Q2 | Output of channel 2; Short-circuit proof, free-wheeling diodes integrated for inductive loads |

Circuit Description

Input Circuit

The control inputs consist of TTL/CMOS-compatible Schmitt triggers with hysteresis. Buffer amplifiers are driven by these stages and convert the logic signal into the necessary form for driving the power output stages. In case of low potential at both inputs the device is switched in inhibit-condition with very low current consumption.

Output Stages

The output stages from a switched H-bridge. Protective circuits make the outputs short-circuit proof from ground up to a supply voltage of 16 V. Positive and negative voltage spikes, which occur when switching inductive loads, are limited by integrated power diodes.

Monitoring and Protective Functions

An internal circuit ensures that all output transistors are turned-OFF if the supply voltage is below the operating range.

Functional Truth Table

| I1 | I2 | Q1 | Q2 | Comments |
|----|----|----|----|---|
| L | L | Z | Z | Device in inhibit condition with very low current consumption; outputs in tristate condition (high impedance) |
| L | H | L | H | Motor turns clockwise |
| H | L | H | L | Motor turns counterclockwise |
| H | H | H | H | Motor brake; both high side transistors turned-ON |

Notes for Output Stage

| Symbol | Value |
|--------|--|
| L | Low side transistor is turned-ON; High side transistor is turned-OFF |
| H | High side transistor is turned-ON; Low side transistor is turned-OFF |
| Z | High side transistor and Low side transistor are turned-OFF |

A monitoring circuit for each output transistor detects whether the particular transistor is active and in this case prevents the corresponding source transistor (sink transistor) from conducting in sink operation (source operation). This effectively guards against crossover currents. Pulse-width operation is possible up to a maximum switching frequency of 1 kHz for any load.

Depending on the load current higher frequencies are possible.

Protective Function

Various errors like short-circuit to + V_s , ground or across the load are detected. All faults result in turn-OFF of the output stages after a delay of 40 μ s and setting of the error flag EF to ground. Changing the inputs resets the error flag.

Output Shorted to Ground Detection

If a high side transistor is switched on and its output is shorted to ground, the output current is limited to typ 11 A. After a delay of 40 μ s all outputs will be switched off and the error flag EF is set to ground.

Output Shorted to + V_s and Overload Detection

An internal circuit detects if the current through the low side transistor is higher than 4 A typ. In this case all outputs are turned-OFF after 40 μ s and the error flag is set to ground. At a junction temperature higher than 160 °C the thermal shutdown turns-OFF, all four output stages commonly and the error flag is set without a delay.

Diagnosis

| Input | | Output | | Diagnosis | | | EF |
|-------|----|--------|----|----------------|------------------|----------|----|
| I1 | I2 | Q1 | Q2 | Shorted to GND | Shorted to V_s | Overload | |
| L | L | Z | Z | Q1, Q2 | Q1, Q2 | – | H |
| L | H | L | H | Q2 | Q1 | X | L |
| H | L | H | L | Q1 | Q2 | X | L |
| H | H | H | H | Q1, Q2 | – | – | L |

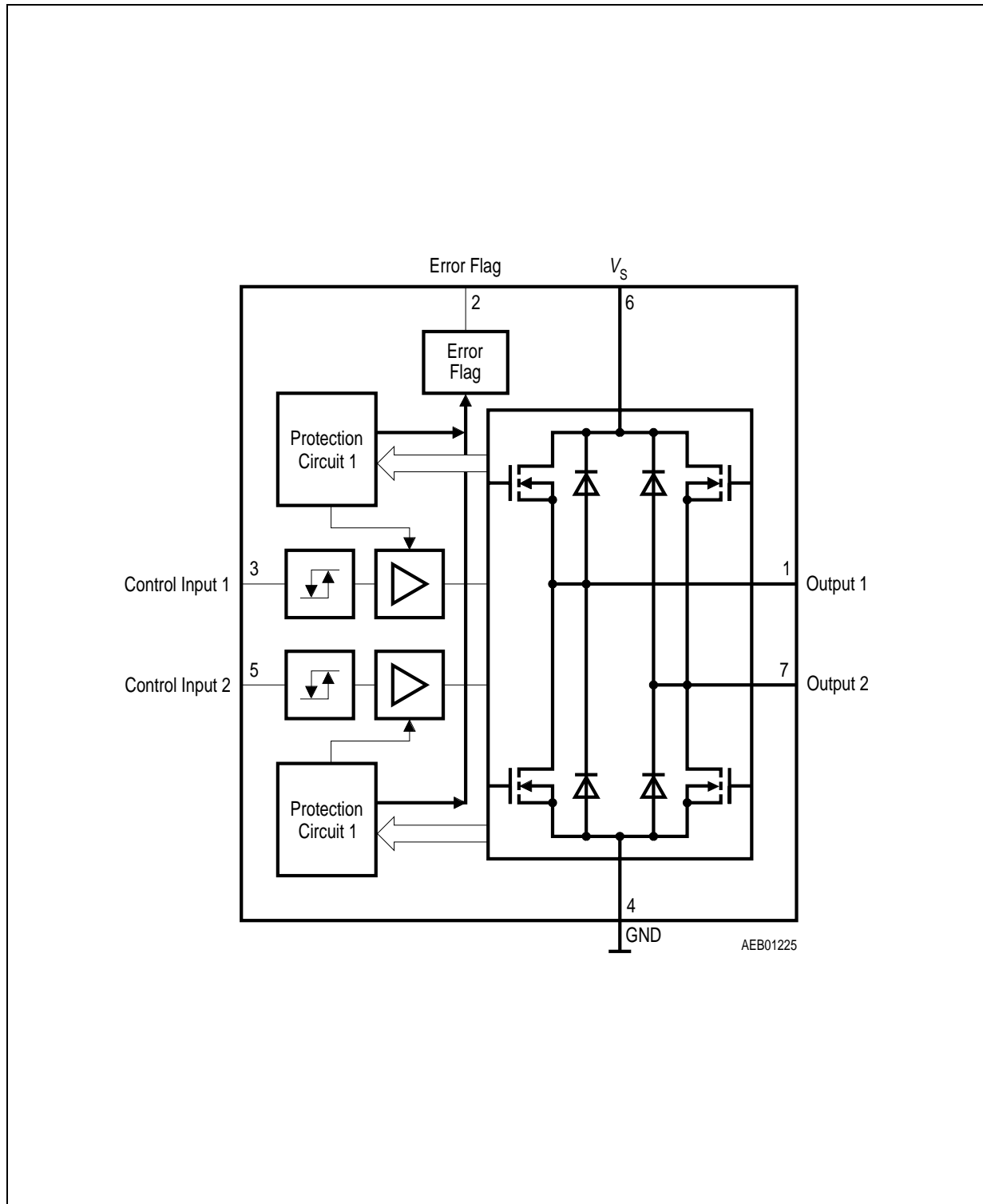

Figure 2 Block Diagram

Electrical Characteristics

Absolute Maximum Ratings

$T_j = -40$ to 150 °C

| Parameter | Symbol | Limit Values | | Unit | Remarks |
|-----------|--------|--------------|------|------|---------|
| | | min. | max. | | |

Voltage

| | | | | | |
|----------------------------|------------|------|----|---|---------------------------|
| Supply voltage | V_S | -0.3 | 40 | V | - |
| Supply voltage | V_S | -1 | - | V | $t < 500$ ms; $I_S < 5$ A |
| Logic input voltage | $V_{11,2}$ | -0.3 | 6 | V | $V_S = 0 - 40$ V |
| Diagnostics output voltage | V_{EF} | -0.3 | 6 | V | - |

Current

| | | | | | |
|------------------------------|-----------|-----|-----|----|-------------------|
| Free-wheeling current | I_F | -4 | 4 | A | $T_j \leq 150$ °C |
| Output current ¹⁾ | I_Q | -4 | 4 | A | - |
| Output current | I_Q | -5 | 5 | A | $t < 2$ ms |
| Junction temperature | T_j | -40 | 150 | °C | - |
| Storage temperature | T_{stg} | -50 | 150 | °C | - |

Thermal Resistance

| | | | | | |
|------------------|------------|---|----|-----|---|
| Junction-case | R_{thjC} | - | 4 | K/W | - |
| Junction-ambient | R_{thjA} | - | 65 | K/W | - |

¹⁾ During overload condition currents higher than 5 A can dynamically occur, before the device shuts off, without any damage to the device.

Note: Stresses above those listed here may cause permanent damage to the device. Exposure to absolute maximum rating conditions for extended periods may affect device reliability.

Operating Range

| Parameter | Symbol | Limit Values | | Unit | Remarks |
|-----------------------------------|------------|--------------|------|------|---------|
| | | min. | max. | | |
| Supply voltage | V_S | 6 | 24 | V | - |
| Logic input voltage | $V_{11,2}$ | -0.3 | 6 | V | - |
| Switching frequency ¹⁾ | f | - | 1 | kHz | - |
| Junction temperature | T_j | -40 | 150 | °C | - |

¹⁾ Depending on load, higher frequencies are possible.

Note: In the operating range the functions given in the circuit description are fulfilled.

Characteristics

$V_S = 6$ to 18 V; $T_j = -40$ to 150 °C

| Parameter | Symbol | Limit Values | | | Unit | Test Condition |
|-----------|--------|--------------|------|------|------|----------------|
| | | min. | typ. | max. | | |

General

| | | | | | | |
|-------------------|----------|---|-----|-----|---------|---|
| Quiescent current | I_q | – | – | 5 | mA | $I_L = 0$ A |
| Quiescent current | I_q | | 20 | 40 | μ A | $T_j = 25$ °C $V_{I1} = V_{I2} = 0$ V; $V_S = 12$ V |
| Quiescent current | I_q | | | 80 | μ A | $V_{I1} = V_{I2} = 0$ V; $V_S = 12$ V |
| Turn-ON delay | t_{d1} | – | – | 20 | μ s | Input to Output |
| Turn-OFF delay | t_{d2} | – | – | 20 | μ s | Input to Output |
| Turn-ON time | t_r | – | – | 20 | μ s | $I_Q = 2.5$ A; cf diagram |
| Turn-OFF time | t_f | – | – | 20 | μ s | $I_Q = 2.5$ A; cf diagram |
| Undervoltage | V_S | – | 5.5 | 5.9 | V | $I_{C ON}$ |
| Undervoltage | V_S | – | 4.5 | 5.5 | V | $I_{C OFF}$ |

Logic

| | | | | | | |
|-----------------------------|--------------|-----|-----|-----|---------|-----------------------------|
| Control inputs | | | | | | |
| H-input voltage | V_{IH} | 2.8 | – | – | V | – |
| L-input voltage | V_{IL} | – | – | 1.2 | V | – |
| Hysteresis of input voltage | ΔV_I | | 0.8 | | V | – |
| H-input current | I_I | 0 | 25 | 50 | μ A | $V_I = V_{IH} = 2.8$ V |
| L-input current | I_I | – 2 | 0 | 2 | μ A | $V_I = V_{IL}$ |
| Diagnostics output | | | | | | |
| Delay time | t_d | 20 | 40 | 75 | μ s | – |
| L-output voltage | V_{FF} | – | – | 0.4 | V | $I = 3$ mA |
| Leakage current | I_{RD} | – | – | 10 | μ A | – |
| Error detection | | | | | | |
| Switching threshold | V_{EU} | 3.5 | 4.5 | 5.5 | V | |
| Overcurrent | I_{F1} | 5 | 7 | 10 | A | $T_j \leq 25$ °C |
| Overcurrent | I_{F1} | 4.5 | 6 | 9 | A | 25 °C < $T_j \leq 150$ °C |

Characteristics (cont'd) $V_S = 6 \text{ to } 18 \text{ V}; T_j = -40 \text{ to } 150 \text{ }^\circ\text{C}$

| Parameter | Symbol | Limit Values | | | Unit | Test Condition |
|-----------|--------|--------------|------|------|------|----------------|
| | | min. | typ. | max. | | |

Outputs

| | | | | | | |
|----------------------------|-----------------|---|---|------|----------|--|
| R_{DSON} (Source) | — | — | — | 0.4 | Ω | $V_S > 6 \text{ V}; T_j = 25 \text{ }^\circ\text{C}^{1)}$ |
| R_{DSON} (Source) | — | — | — | 0.65 | Ω | $V_S > 6 \text{ V}; T_j = 150 \text{ }^\circ\text{C}^{1)}$ |
| R_{DSON} (Source) | — | — | — | 0.4 | Ω | $V_S > 6 \text{ V}; T_j = 25 \text{ }^\circ\text{C}^{1)}$ |
| R_{DSON} (Source) | — | — | — | 0.65 | Ω | $V_S > 6 \text{ V}; T_j = 150 \text{ }^\circ\text{C}^{1)}$ |
| Diode forward voltage | V_{FU} | — | — | 1.5 | V | $I_F = 3 \text{ A}$ |
| Diode forward voltage | V_{FL} | — | — | 1.5 | V | $I_F = 3 \text{ A}$ |

¹⁾ Values for R_{DSON} are for $t > 100 \text{ } \mu\text{s}$ after applying $+V_S$ and $t > 400 \text{ } \mu\text{s}$ after changing from $V_{\text{I1}} = V_{\text{I2}} = \text{L}$ to V_{I1} or $V_{\text{I2}} = \text{H}$.

Note: The listed characteristics are ensured over the operating range of the integrated circuit. Typical characteristics specify mean values expected over the production spread. If not otherwise specified, typical characteristics apply at $T_j = 25 \text{ }^\circ\text{C}$ and the given supply voltage.

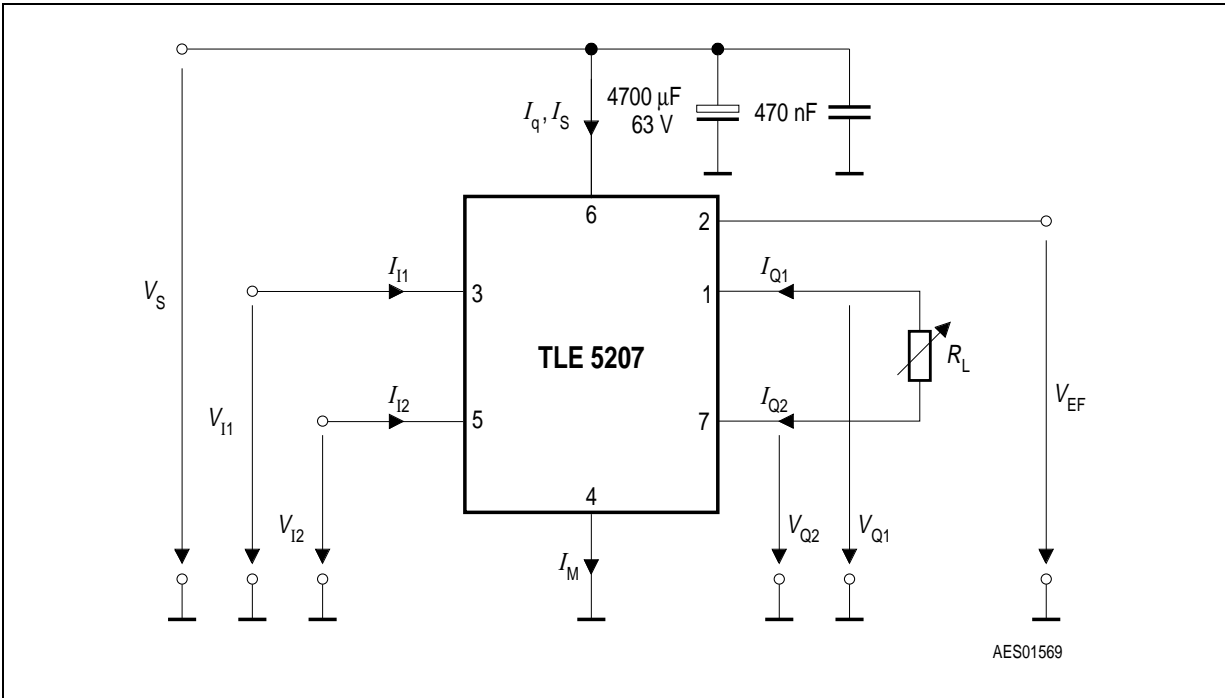

Figure 3 Test Circuit

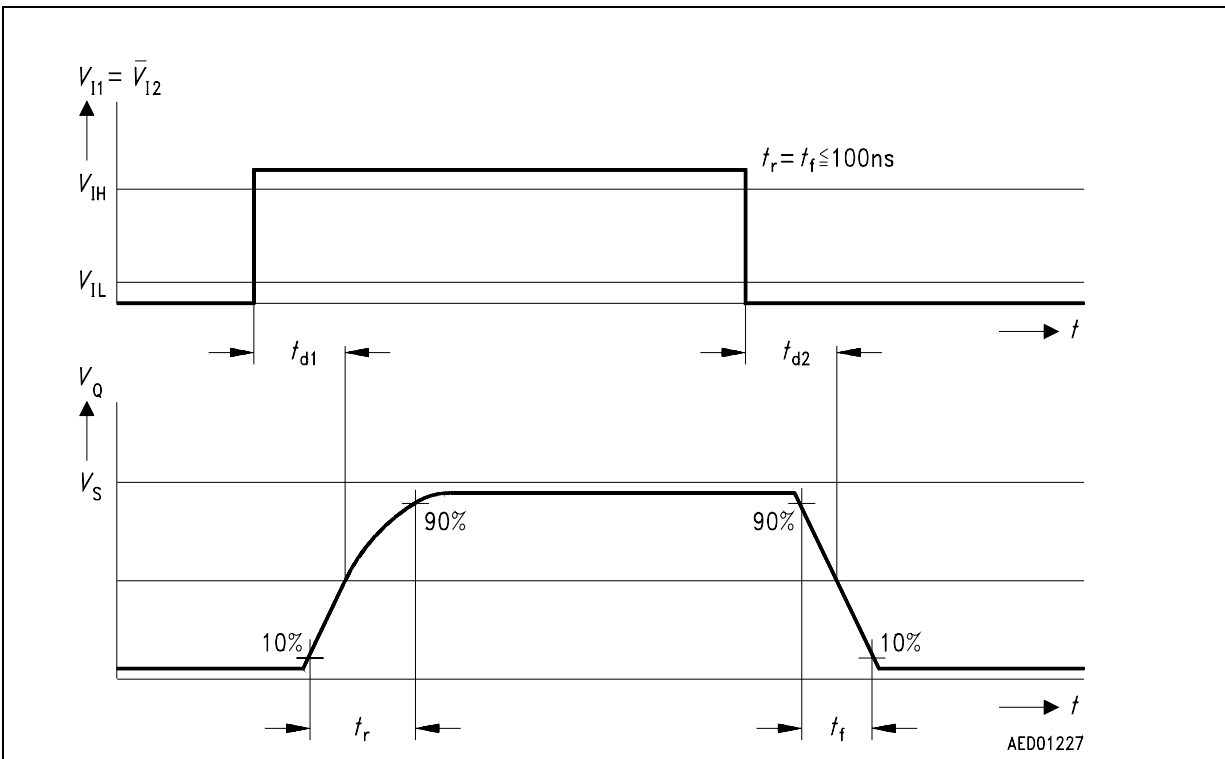

Figure 4 Timing Diagram

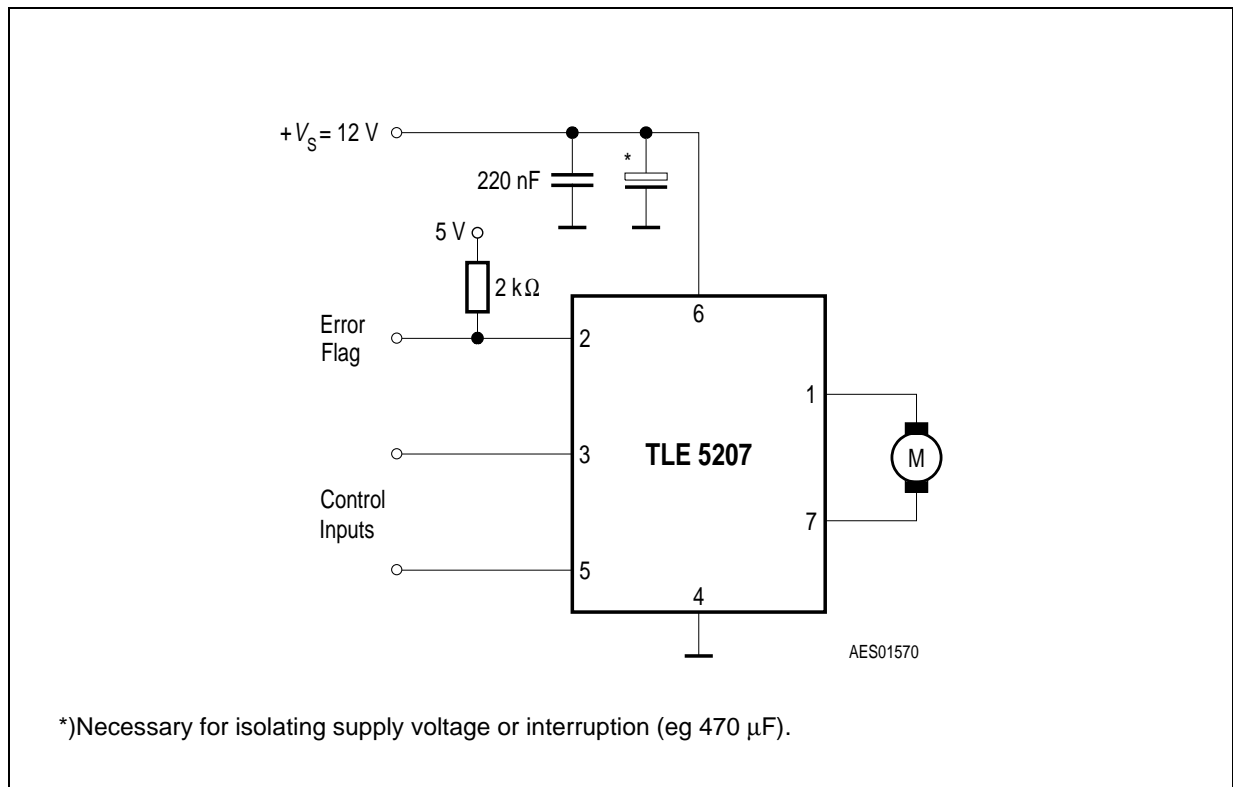
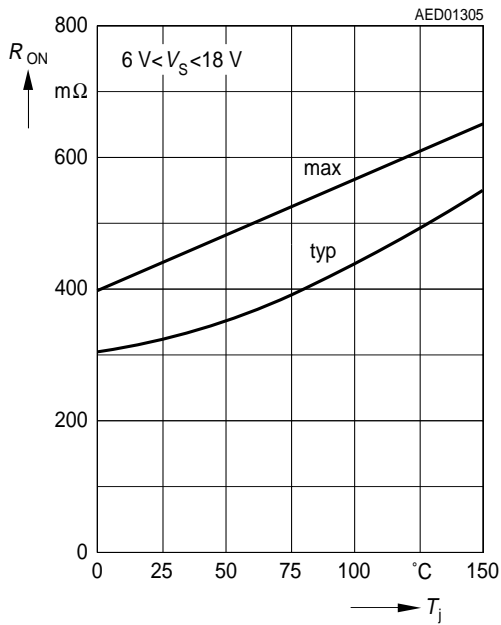

Figure 5 Application Circuit

Diagrams

R_{ON} Resistance of Output Stage over Temperature



Output Voltage on Diagnostics Output versus Current

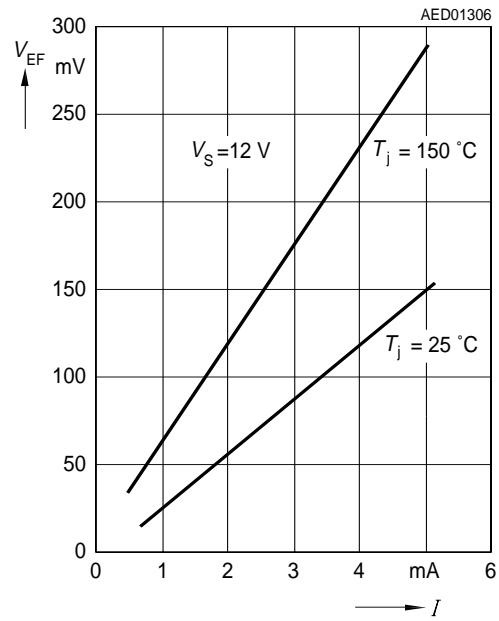

Forward Current of Upper Free-Wheeling Diode versus Voltage

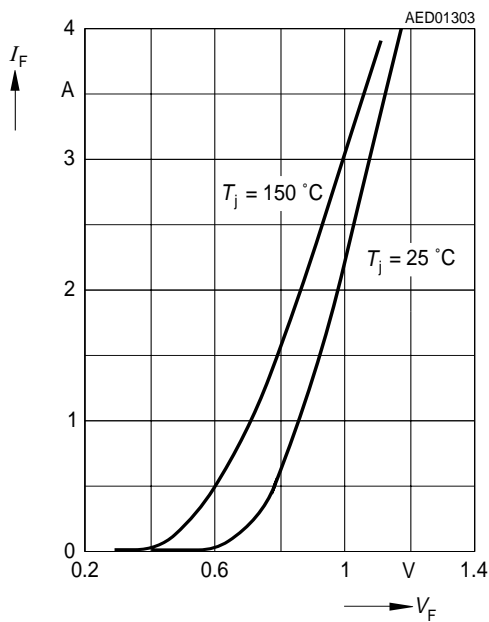

Forward Current of Lower Free-Wheeling Diode versus Voltage

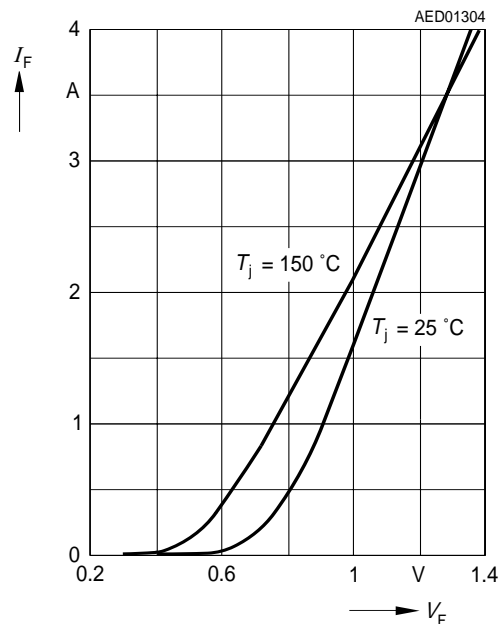

Overcurrent Threshold versus Temperature

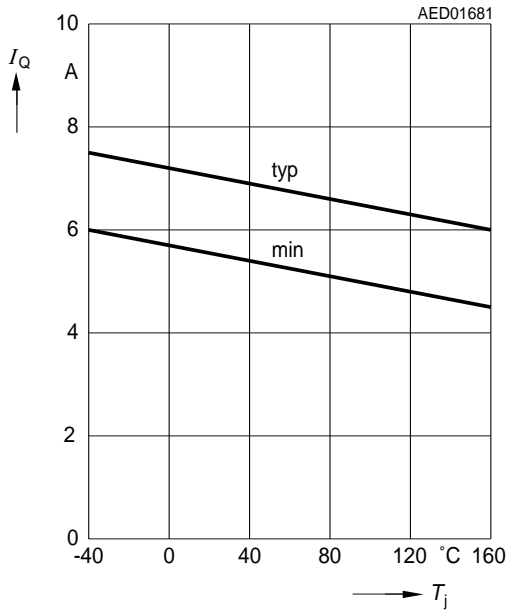

Quiescent Current (device active) versus Temperature

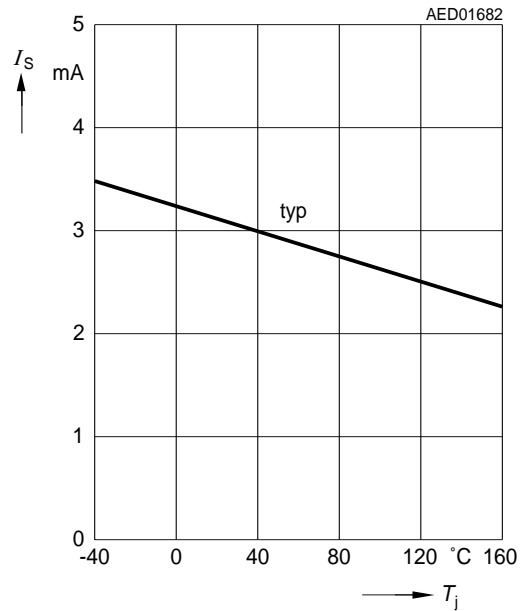

Input Threshold versus Temperature

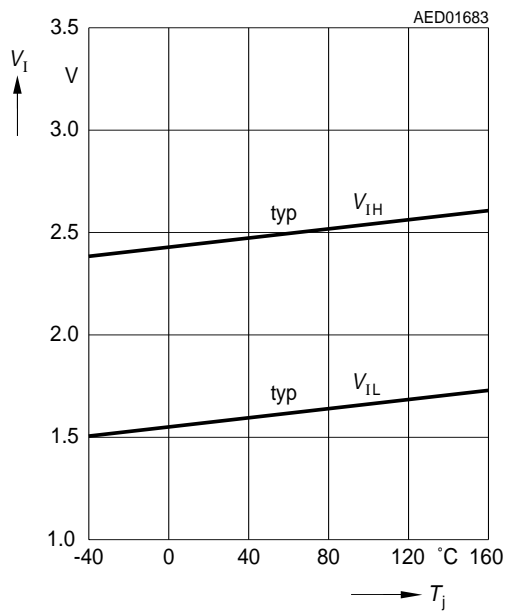

Switching Threshold V_{EU} versus Temperature

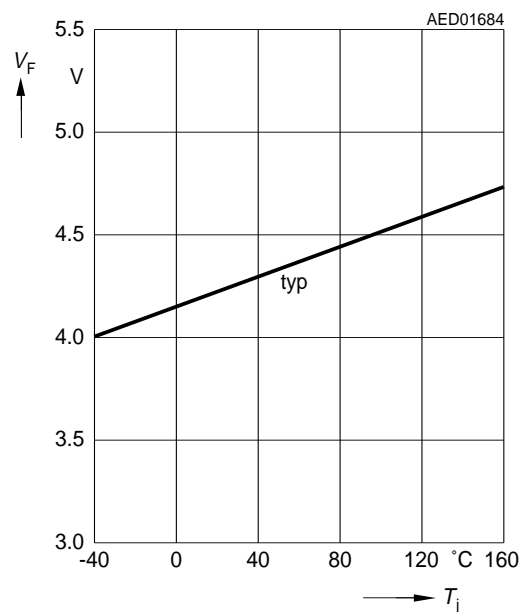

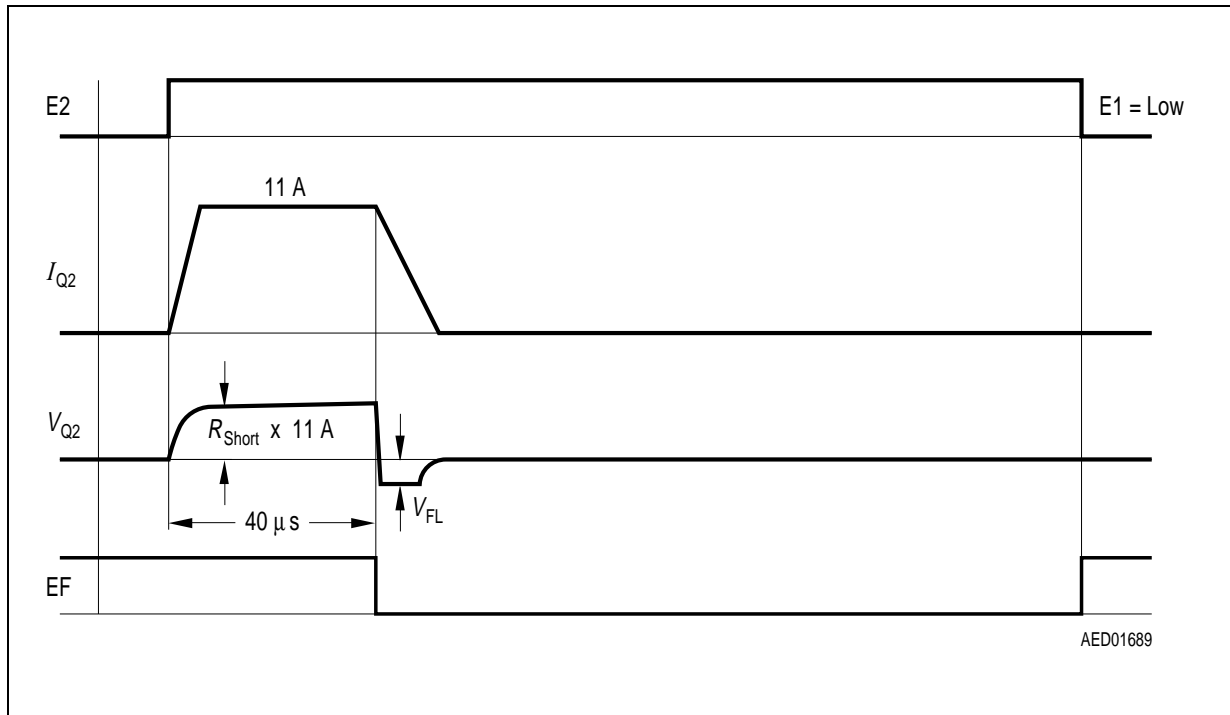

Figure 6 Timing Diagram for Output Shorted to Ground (E1 = High)

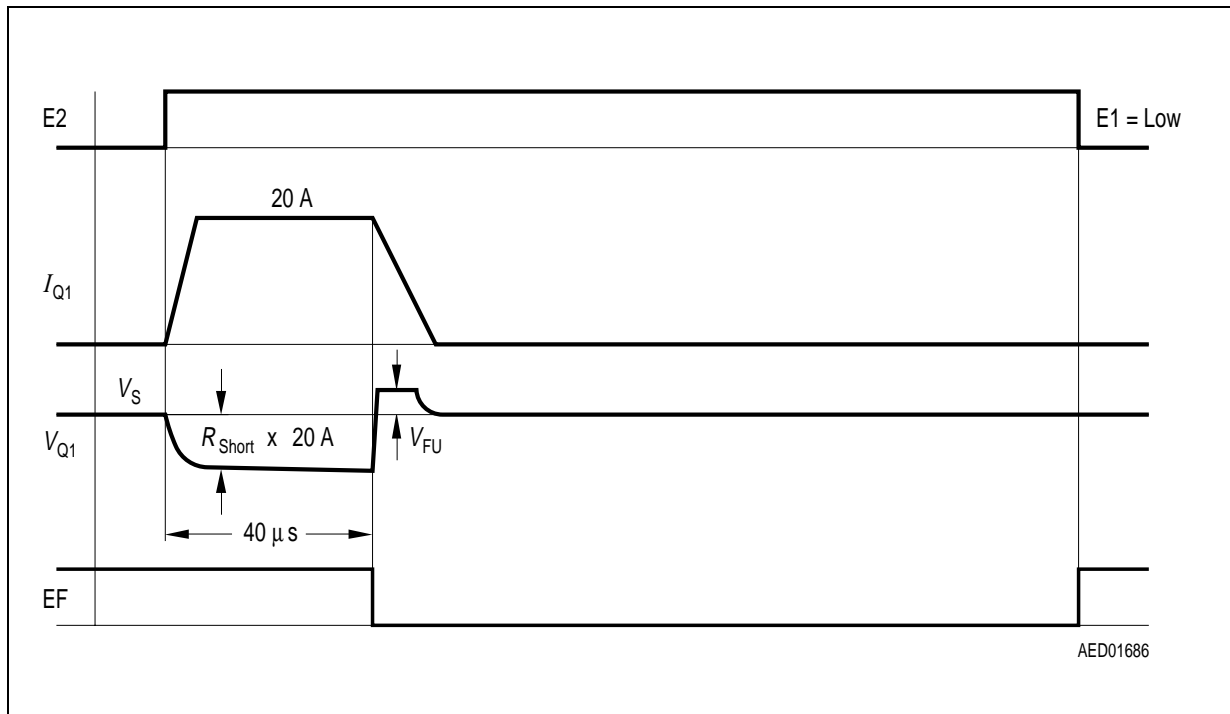

Figure 7 Timing Diagram for Output Shorted to V_s (E1 = High)

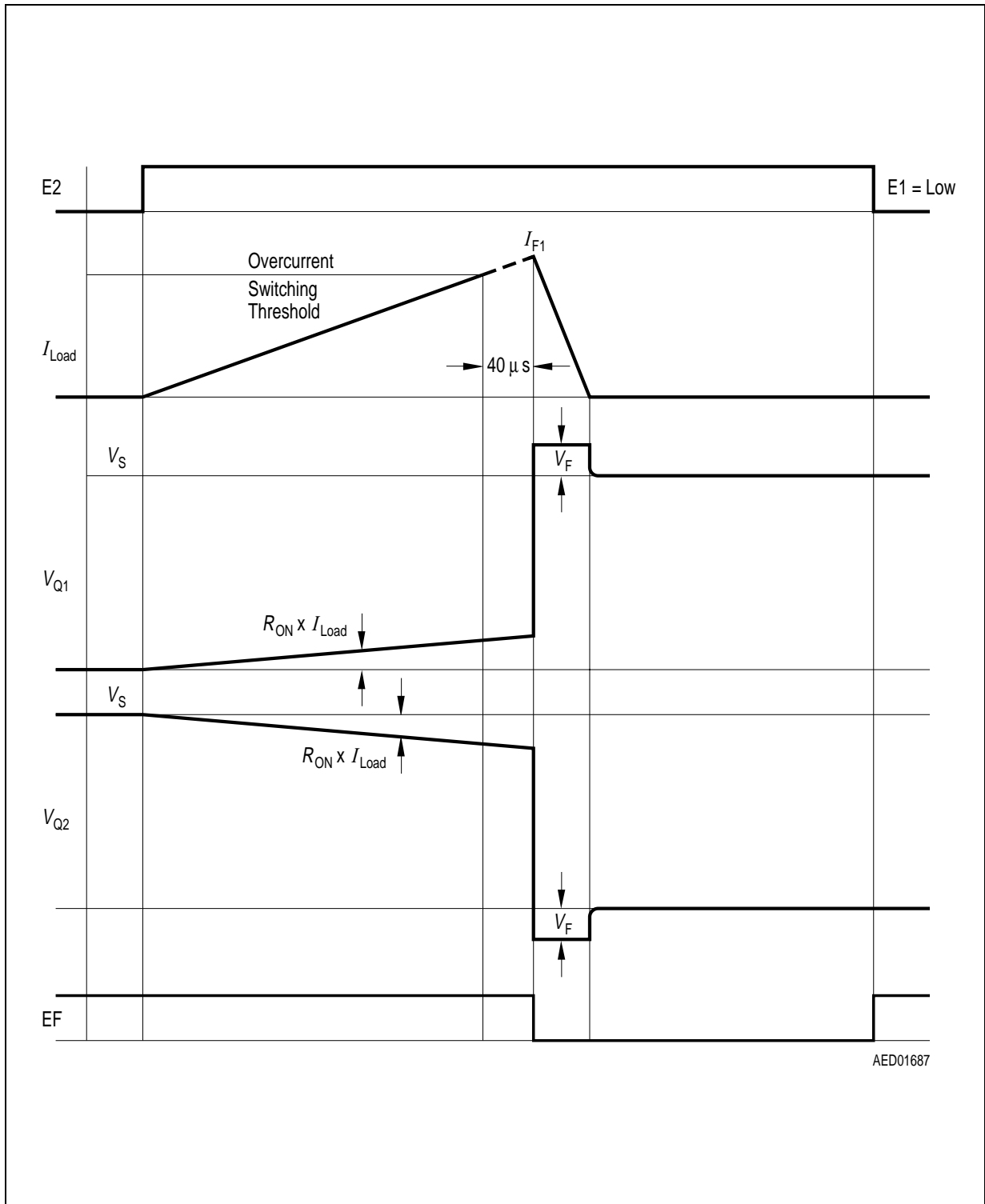
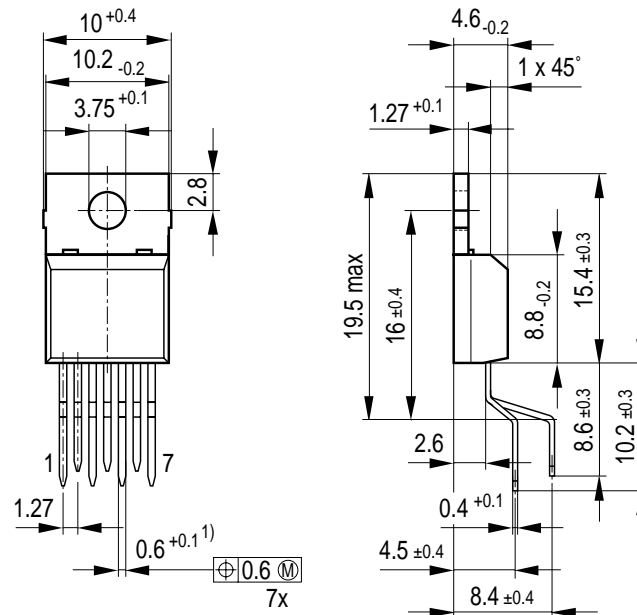

Figure 8 Timing Diagram for Overcurrent and E1 = E2 Inverted (Device not inhibited)

Package Outlines

P-TO220-7-1 (Plastic Transistor Single Outline Package)



1) $0.75^{-0.15}$ at dam bar (max 1.8 from body)

1) $0.75^{-0.15}$ im Dichtstegbereich (max 1.8 vom Körper)

GPT05108

Sorts of Packing

Package outlines for tubes, trays etc. are contained in our Data Book "Package Information".

Dimensions in mm

P-TO220-7-8
(Plastic Transistor Single Outline Package)

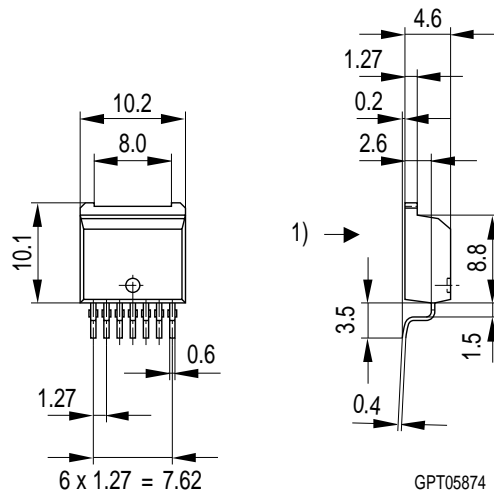

1) shear and punch direction burr free surface

Sorts of Packing

Package outlines for tubes, trays etc. are contained in our Data Book "Package Information".

SMD = Surface Mounted Device

Dimensions in mm