

Type	Ordering code	Package
TDA 5800	Q67000-A1777	DIP 22

The TDA 5800 contains a 4-stage broadband amplifier with controllable gain, a limiter, a synchronous demodulator for AM, an FM demodulator for generating the AFC voltage, and an AGC generator for the IF amplifier and tuner.

An external PNP transistor is required for a VTR connection according to the IEC standard.

### Features

- Suitable for standard VTR connection
- Switchable AFC
- Fast control
- Positive and negative video output

### Maximum ratings

Supply voltage	$V_S$	16.5	V
Junction temperature	$T_j$	150	°C
Storage temperature range	$T_{stg}$	-40 to 125	°C
Thermal resistance (system-air)	$R_{thSA}$	70	K/W

### Operating range

Supply voltage	$V_S$	10 to 15.8	V
IF frequency	$f_{IF}$	15 to 75	MHz
Ambient temperature	$T_A$	0 to 70	°C

**Characteristics** $V_S = 13 \text{ V}; T_A = 25 \text{ }^\circ\text{C}$ 

		min	typ	max	
Current consumption	$I_{16}$		60		mA
Stab. reference voltage	$V_{14/1}$		6.0		Vdc
Tuner control current	$I_{17}$	3.0	4.0		mA
Tuner AGC threshold	$V_{18/1}$	0		5.0	Vdc
Gating pulse voltage	$V_{2 \text{ pos}}$	-2.0	3.0	$V_{16}-1$	V
	$V_{2 \text{ neg}}$	-15.0	-3.0	2.0	V
Input voltage at $G_{\text{max}}$ ( $V_{5 \text{ pp}} = 3 \text{ V}$ )	$V_{22/21}$			100	$\mu\text{V}$
AGC range	$\Delta G$		60		dB
IF control voltage for $G_{\text{max}}$	$V_{3/1}$	0			Vdc
IF control voltage for $G_{\text{min}}$	$V_{3/1}$			5.0	Vdc
IF control voltage for VTR switchover	$V_{3/1}$	8.0		$V_{16}$	Vdc
AFC output current	$I_9$		$\pm 1.0$		mA
AFC switch OFF ( $V_{11} = V_{12}; R = 10 \text{ k}\Omega$ )	$V_{11/1}$	0		4.0	Vdc
AFC switch ON ( $V_{11} = V_{12}; R = \infty$ )	$V_{11/1}$		5.3		Vdc
AFC characteristics ( $di/df > 0$ )	$V_{15/1}$	3.0		$V_{16}$	Vdc
AFC characteristics ( $di/df < 0$ )	$V_{15/1}$	0		1.0	Vdc
Video output voltage pos. ( $R_L = \infty$ )	$V_{q5}$		3.0		Vdc
Sync pulse level	$V_{5/1}$		2.0		Vdc
DC voltage ( $V_3 = 5 \text{ V}; V_{22/21} = 0$ )	$V_{5/1}$		5.3		Vdc
Output current to ground across $R$	$I_{q5}$		-5.0		mA
Output current (to +)	$I_{q5}$		2.0		mA
Output resistance	$R_{q5}$		150		$\Omega$
Video output voltage neg. ( $R_L = \infty$ )	$V_{q6 \text{ pp}}$		3.0		V
Sync pulse level	$V_{6/1 \text{ pp}}$		$V_{16}-2$		V
DC voltage ( $V_3 = 5 \text{ V}; V_{22/21} = 0$ )	$V_{6/1 \text{ pp}}$		$V_{16}-5.3$		V
Output current to ground across $R$	$I_{q6}$		-5.0		mA
Output current (to +)	$I_{q6}$		1.0		mA
VTR output voltage neg.	$V_{q7 \text{ pp}}$		1.0		V
$R_L = \infty$ ; VTR recording					
Sync pulse level	$V_{7/1}$		$V_{16}-1.2$		Vdc
$R_L = \infty$ ; VTR recording					
DC voltage	$V_{7/1}$		$V_{16}-2.3$		Vdc
$V_3 = 5 \text{ V}; V_{22/21} = 0$					
DC voltage	$V_{7/1}$		$V_{16}-0.9$		Vdc
$V_3 \geq 8 \text{ V}; \text{VTR playback}$					
Output current	$I_{q7}$		-5.0		mA
to ground across $R$					
Output current (to +)	$I_{q7}$		1.0		mA
Video amplifier VTR playback	$V$		3.0		
$V = V_5/V_8; V_8 = 1 \text{ V}_{\text{pp}}$					

**Additional application data**  
(not measured)

		min	typ	max	
Input impedance	$Z_{i, 22/21}$		1.8/2		k $\Omega$ /pF
Output impedance	$Z_{q, 10/13}$		6.6/2		k $\Omega$ /pF
AFC input impedance	$Z_{i, 11/12}$		20		k $\Omega$
Output resistance	$R_{q, 6}$		150		$\Omega$
Output resistance	$R_{q, 7}$		150		$\Omega$
Residual IF (basic frequency)	$V_5; V_6$		10		mV
Video bandwidth (-3 dB) VTR recording	$B_{video}$		6.0		MHz
Video bandwidth (VTR recording $V_{8, pp} = 1$ V)	$B_{video}$		10.0		MHz
Intermodulation ratio with reference to $f_{CC}$ (sound-color-beat frequency)	a		45		dB

**Pulse diagram**

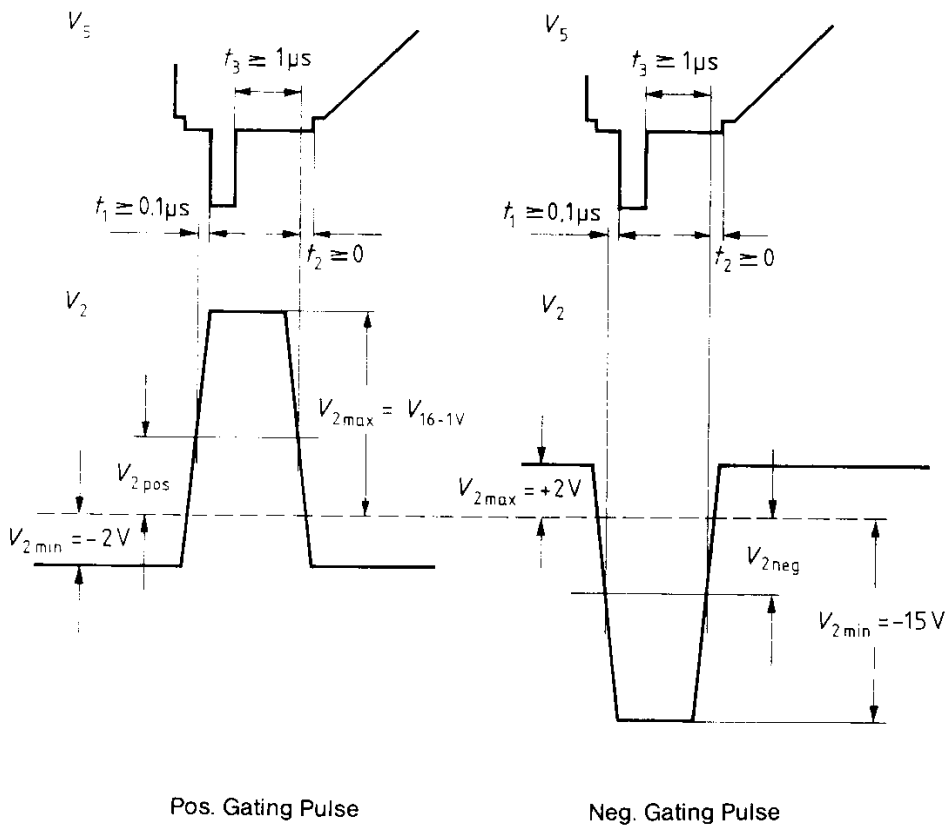

Block diagram and measurement circuit

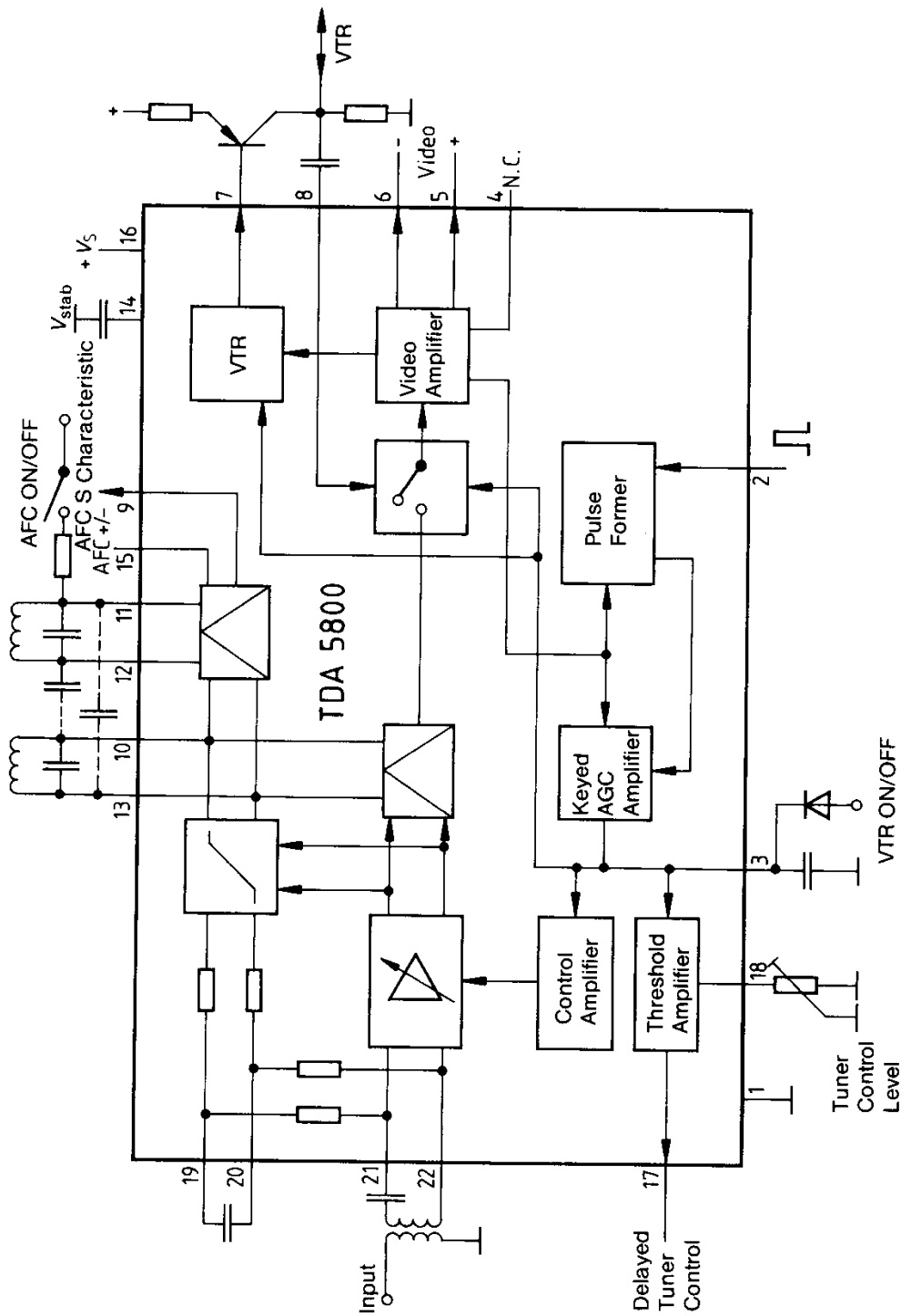

Application circuit

