

Dual Operational Amplifier with Darlington Input

TBC 2332
TBE 2335

Features

- High input impedance
- Wide common-mode range
- Large supply voltage range
- Large control range
- Wide temperature range (TBC 2332 B)
- Open collector output
- NPN Darlington input
- Low input current
- Internally frequency-compensated

Bipolar IC

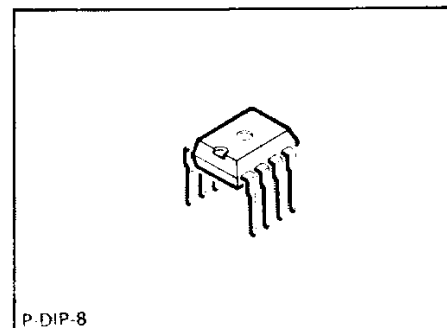

Applications

- Amplifier
- Comparator
- Level converter
- Impedance converter
- Driver

Pin Configuration (top view)

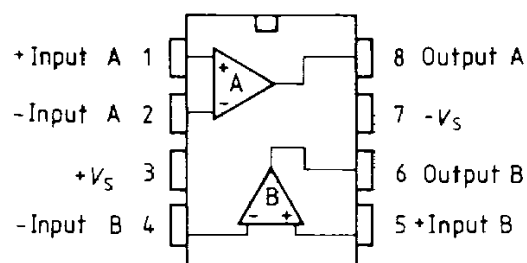

Type	Ordering Code	Package
☒ TBC 2332 B	Q67000-A2500	P-DIP-8
☒ TBE 2335 B	Q67000-A1165	P-DIP-8

These op amps are economic and versatile. Owing to their excellent performance qualities, they are well suited for a wide scope of applications, as in measurement and control engineering, automotive electronics, AF circuits, analog computers, etc. The low input current of these amplifiers is particularly advantageous for measurement and control systems.

Circuit Diagram of one Op Amp

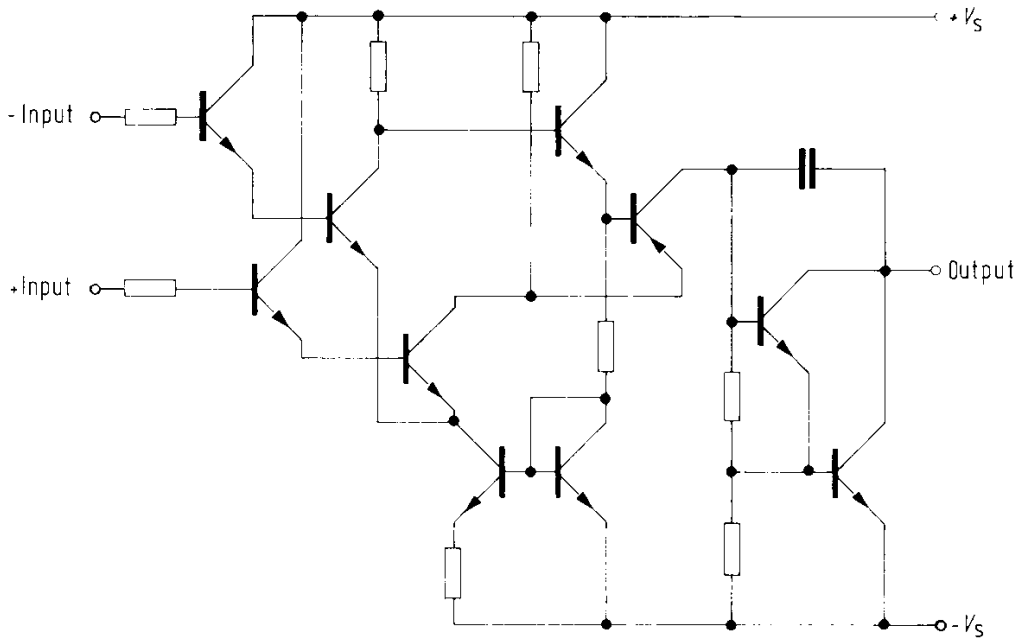

Absolute Maximum Ratings (TBC 2332)

Parameter	Symbol	Limit Values	Unit
Supply voltage	V_S	± 15	V
Output current	I_Q	70	mA
Differential input voltage $V_S = \pm 13$ to ± 15 V $V_S = \pm 2$ to ± 13 V	V_{ID} V_{ID}	± 13 $\pm V_S$	V
Junction temperature	T_j	150	$^{\circ}\text{C}$
Storage temperature range	T_{stg}	-55 to 125	$^{\circ}\text{C}$
Thermal resistance system - air	$R_{th SA}$	100	K/W

Operating Range (TBC 2332)

Supply voltage	V_S	± 2 to ± 15	V
Ambient temperature	T_A	-55 to 125	$^{\circ}\text{C}$

Characteristics (TBC 2332)

$V_S = \pm 5 \text{ V to } \pm 15 \text{ V}$

Parameter	Symbol	Limit Values $T_A = 25^\circ\text{C}$			Limit Values $T_A = -55$ to 125°C		Unit
		min.	typ.	max.	min.	max.	
Open-loop supply current consumption, total	I_S		0.5	1.5		1.5	mA
Input offset voltage $R_G = 50 \Omega$	V_{IO}	-10		10	-15	15	mV
Input offset current	I_{IO}	-5		5	-10	10	nA
Input current	I_I		5	15		25	nA
Control range $R_L = 2 \text{ k}\Omega$, $V_S = \pm 15 \text{ V}$	$V_{Q \text{ pp}}$	14.9		-14	14.8	-14	V
$R_L = 620 \Omega$, $V_S = \pm 15 \text{ V}$	$V_{Q \text{ pp}}$	14.9		-12.5	14.8	-12	V

Characteristics (TBC 2332)

$V_S = \pm 5 \text{ V to } \pm 15 \text{ V}$; $R_L = 2 \text{ k}\Omega$, unless otherwise specified

Parameter	Symbol	Limit Values $T_A = 25^\circ\text{C}$			Limit Values $T_A = -55$ to 125°C		Unit
		min.	typ.	max.	min.	max.	
Input impedance $f = 1 \text{ kHz}$	Z_i		3				M Ω
Open-loop voltage gain $f = 100 \text{ Hz}$	G_{V0}	80	83		75		dB
$R_L = 10 \text{ k}\Omega$, $f = 100 \text{ Hz}$	G_{V0}		88				dB
Output reverse current	I_{QR}			1		5	μA
Common-mode input voltage range	V_{IC}	V_S		$-V_S+2.0$	V_S	$-V_S+3$	V
Common-mode rejection	k_{CMR}	75	80		70		dB
Supply voltage rejection $G_V = 100$	k_{SVR}		25	100		100	$\mu\text{V/V}$
Temperature coefficient of V_{IO} $R_G = 50 \Omega$	α_{VIO}		4	25		50	$\mu\text{V/K}$
Temperature coefficient of I_{IO} $R_G = 50 \Omega$	α_{IIO}		50				pA/K
Output saturation voltage $I_Q = 10 \text{ mA}$	$V_{Q \text{ sat}}$			1			V
Slew rate for non-inverting operation ¹⁾	SR		0.5				V/ μs
Slew rate for inverting operation ¹⁾	SR		0.5				V/ μs

¹⁾ For the relationship between power bandwidth and slew rate refer to "Introduction to Operational Amplifiers"

Absolute Maximum Ratings (TBE 2335)

Parameter	Symbol	Limit Values	Unit
Supply voltage	V_S	± 15	V
Output current	I_Q	70	mA
Differential input voltage $V_S = \pm 13$ to ± 15 V $V_S = \pm 2$ to ± 13 V	V_{ID} V_{ID}	± 13 $\pm V_S$	V
Junction temperature Storage temperature range	T_j T_{stg}	150 -55 to 125	$^{\circ}\text{C}$ $^{\circ}\text{C}$
Thermal resistance system – air	$R_{th SA}$	100	K/W

Operating Range (TBE 2335)

Supply voltage	V_S	± 2 to ± 15	V
Ambient temperature	T_A	-25 to 85	$^{\circ}\text{C}$

Characteristics (TBE 2335)

$V_S = \pm 2$ V, $R_L = 2$ k Ω

Parameter	Symbol	Limit Values $T_A = 25^{\circ}\text{C}$			Limit Values $T_A = -55$ to 125°C		Unit
		min.	typ.	max.	min.	max.	
Input offset voltage $R_G = 50 \Omega$	V_{IO}	-10		10	-15	15	mV
Input offset current	I_{IO}	-5		5	-10	10	nA
Input current	I_I		5	15		25	nA
Open-loop voltage gain $f = 100$ Hz	G_{V0}	75			70		dB

Characteristics (TBE 2335)

$V_S = \pm 5$ V to ± 15 V; $R_L = 2$ k Ω , unless otherwise specified

Parameter	Symbol	Limit Values $T_A = 25^{\circ}\text{C}$			Limit Values $T_A = -25$ to 85°C		Unit
		min.	typ.	max.	min.	max.	
Open-loop supply current consumption, total	I_S		0.5	1.5		1.5	mA
Input offset voltage $R_G = 50 \Omega$	V_{IO}	-15		15	-18	18	mV
Input offset current	I_{IO}	-10		10	-20	20	nA
Input current	I_I		5	25		35	nA
Control range $V_S = \pm 15$ V $R_L = 620 \Omega$, $V_S = \pm 15$ V	$V_{Q pp}$ $V_{Q pp}$	14.9		-14	14.8	-14	V
		14.9		-12.5	14.8	-12	V

Characteristics (TBE 2335)

$V_S = \pm 5 \text{ V to } \pm 15 \text{ V}; R_L = 2 \text{ k}\Omega$,
unless otherwise specified

Parameter	Symbol	Limit Values $T_A = 25 \text{ }^\circ\text{C}$			Limit Values $T_A = -25$ to $85 \text{ }^\circ\text{C}$		Unit
		min.	typ.	max.	min.	max.	
Input impedance $f = 1 \text{ kHz}$	Z_i		3				$\text{M}\Omega$
Open-loop voltage gain $f = 100 \text{ Hz}$ $R_L = 10 \text{ k}\Omega, f = 100 \text{ Hz}$	G_{V0} G_{V0}	75	80 85		75		dB dB
Output reverse current	I_{QR}			10		20	μA
Common-mode input voltage range	V_{IC}	$-V_S + 2.0$		$V_S - 0.5$	$-V_S + 3$	$-V_S - 0.8$	V
Common-mode rejection	K_{CMR}	70	78		70		dB
Supply voltage rejection $G_V = 100$	K_{SVR}		25	100		100	$\mu\text{V/V}$
Temperature coefficient of V_{IO} $R_G = 50 \text{ }\Omega$	α_{VIO}		4	25		50	$\mu\text{V/K}$
Temperature coefficient of I_{IO} $R_G = 50 \text{ }\Omega$	α_{IIO}		50				pA/K
Output saturation voltage $I_Q = 10 \text{ mA}$	$V_{Q \text{ sat}}$			1			V
Slew rate for non-inverting operation ¹⁾	SR		0.5				$\text{V}/\mu\text{s}$
Slew rate for inverting operation ¹⁾	SR		0.5				$\text{V}/\mu\text{s}$

Characteristics (TBE 2335)

$V_S = \pm 2 \text{ V}, R_L = 2 \text{ k}\Omega$

Input offset voltage $R_G = 50 \text{ }\Omega$	V_{IO}	-17		17	-20	20	mV
Input offset current	I_{IO}	-10		10	-20	20	nA
Input current	I_i		5	25		35	nA
Open-loop voltage gain $f = 100 \text{ Hz}$	G_{V0}	70			70		dB

¹⁾ For the relationship between power bandwidth and slew rate refer to "Introduction to Operational Amplifiers"