

Chip resistor networks

MNR04 (1005 × 4 size)

●Features

- 1) Extremely small and light
Area ratio is 60% smaller than that of chip 3216 (MNR14), while weight ratio has been cut 75%.
- 2) High-density mounting
Can be mounted even more densely than four 1005 chips (MCR01), and mounting costs are lower.
- 3) Can be mounted on a wide variety of devices
Squared corners make it excellent for mounting on image recognition devices.
- 4) Convex electrodes
Easy to check the fillet after soldering is finished.
- 5) ROHM resistors comply with the international standard ISO-9001.
Furthermore, changes to the design and specifications of products may occur without notice. Therefore, before ordering or using this product, please make sure to reconfirm the specification sheet before ordering or using this product.

●Ratings

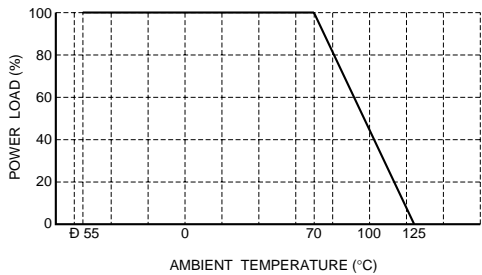
Item	Conditions	Specifications		
Rated power	<p>Power must be derated according to the power derating curve in Figure 1 when ambient temperature exceeds 70°C.</p>  <p style="text-align: center;">Fig.1</p>	0.063W (1 / 16W) at 70°C		
Rated voltage	<p>The voltage rating is calculated by the following equation. If the value obtained exceeds the limiting element voltage, the voltage rating is equal to maximum operating voltage.</p> $E = \sqrt{P \times R}$ <p style="margin-left: 100px;">E : Voltage rating (V) P : Power rating (W) R : Nominal resistance (Ω)</p>	<table border="1" style="width: 100%;"> <tr> <td>Limiting element voltage</td> <td>25V</td> </tr> </table>	Limiting element voltage	25V
Limiting element voltage	25V			
Nominal resistance	See Table 1 .			
Operating temperature		-55°C~+125°C		

Resistors

Jumper type

Resistance	Max.50mΩ
Rated current	1A
Operating temperature	-55°C~+125°C

Table 1

Resistance tolerance	Resistance range (Ω)	Resistance temperature coefficient (ppm / °C)
J (±5%)	10≤R≤1M (E24)	±300

●Before using components in circuits where they will be exposed to transients such as pulse loads (short-duration, high-level loads), be certain to evaluate the component in the mounted state. In addition, the reliability and performance of this component cannot be guaranteed if it is used with a steady state voltage that is greater than its rated voltage.

●Characteristics

Item	Guaranteed value		Test conditions (JIS C 5201-1)
	Resistor type	Jumper type	
Resistance	J : ±5%	Max. 50mΩ	JIS C 5201-1 4.5
Variation of resistance with temperature	See Table.1		JIS C 5201-1 4.8 Measurement : -55 / +25 / +125°C
Overload	± (2.0%+0.1Ω)	Max. 50mΩ	JIS C 5201-1 4.13 Rated voltage (current) ×2.5, 2s. Limiting Element Voltage×2 : 50V
Solderability	A new uniform coating of minimum of 95% of the surface being immersed and no soldering damage.		JIS C 5201-1 4.17 Rosin-Ethanol (25%WT) Soldering condition : 235±5°C Duration of immersion : 2.0±0.5s.
Resistance to soldering heat	± (1.0%+0.05Ω) No remarkable abnormality on the appearance.	Max. 50mΩ	JIS C 5201-1 4.18 Soldering condition : 260±5°C Duration of immersion : 10±1s.
Rapid change of temperature	± (1.0%+0.05Ω)	Max. 50mΩ	JIS C 5201-1 4.19 Test temp. : -55°C~+125°C 5cyc
Damp heat, steady state	± (3.0%+0.1Ω)	Max. 50mΩ	JIS C 5201-1 4.24 40°C, 93%RH Test time : 1,000h~1,048h
Endurance at 70°C	± (3.0%+0.1Ω)	Max. 50mΩ	JIS C 5201-1 4.25.1 Rated voltage (current), 70°C 1.5h : ON – 0.5h : OFF Test time : 1,000h~1,048h
Endurance	± (3.0%+0.1Ω)	Max. 50mΩ	JIS C 5201-1 4.25.3 125°C Test time : 1,000h~1,048h
Resistance to solvent	± (1.0%+0.05Ω)	Max. 50mΩ	JIS C 5201-1 4.29 23±5°C, Immersion cleaning, 5±0.5min. Solvent : 2-propanol
Bend strength of the end face plating	± (1.0%+0.05Ω) Without mechanical damage such as breaks.	Max. 50mΩ	JIS C 5201-1 4.33

Resistors

●External dimensions (Units: mm)

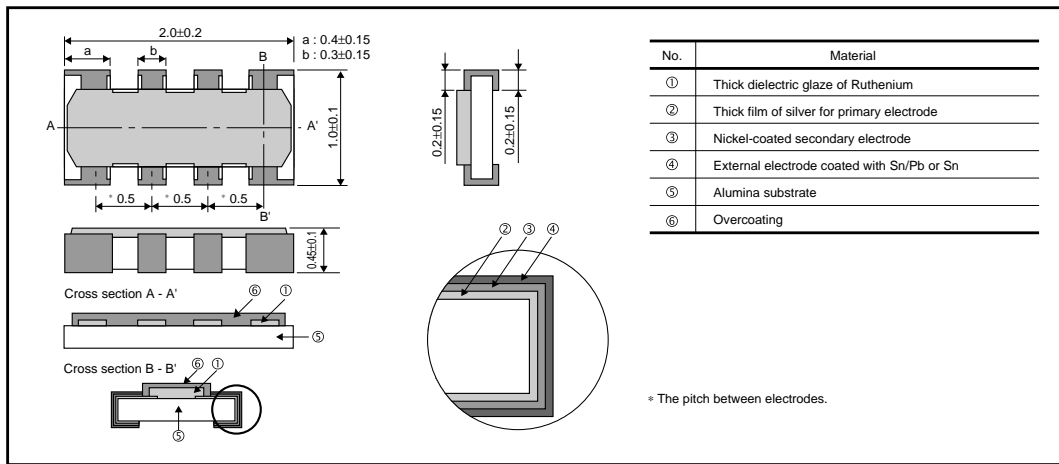

●Equivalent circuit

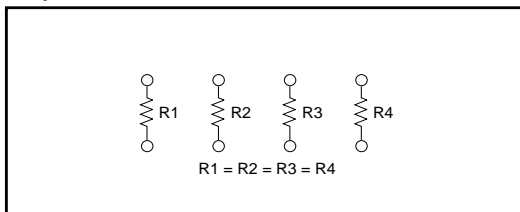

Resistors

●Packaging

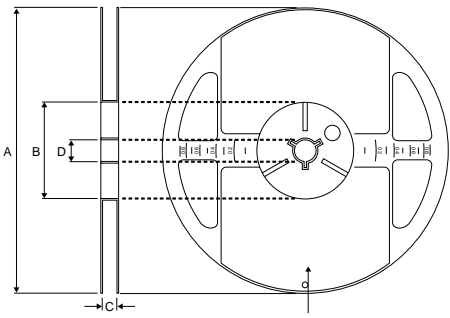
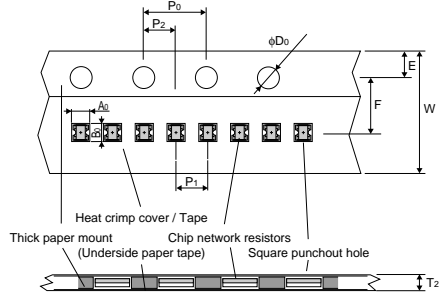
Reel	Taping																												
 <p style="text-align: center;">EIAJ ET-7200A compliant</p> <p style="text-align: center;">(Units : mm)</p> <table border="1" style="width: 100%; border-collapse: collapse; margin-top: 10px;"> <thead> <tr> <th>A</th> <th>B</th> <th>C</th> <th>D</th> </tr> </thead> <tbody> <tr> <td style="text-align: center;">$\phi 180 \begin{smallmatrix} 0 \\ -3 \end{smallmatrix}$</td> <td style="text-align: center;">$\phi 60 \begin{smallmatrix} +1 \\ 0 \end{smallmatrix}$</td> <td style="text-align: center;">$9 \begin{smallmatrix} +1.0 \\ 0 \end{smallmatrix}$</td> <td style="text-align: center;">$\phi 13 \pm 0.2$</td> </tr> </tbody> </table>	A	B	C	D	$\phi 180 \begin{smallmatrix} 0 \\ -3 \end{smallmatrix}$	$\phi 60 \begin{smallmatrix} +1 \\ 0 \end{smallmatrix}$	$9 \begin{smallmatrix} +1.0 \\ 0 \end{smallmatrix}$	$\phi 13 \pm 0.2$	 <p style="text-align: right;">(Units : mm)</p> <table border="1" style="width: 100%; border-collapse: collapse; margin-top: 10px;"> <thead> <tr> <th>W</th> <th>F</th> <th>E</th> <th>A₀</th> <th>B₀</th> </tr> </thead> <tbody> <tr> <td style="text-align: center;">8.0 ± 0.3</td> <td style="text-align: center;">3.5 ± 0.05</td> <td style="text-align: center;">1.75 ± 0.1</td> <td style="text-align: center;">1.2 ± 0.1</td> <td style="text-align: center;">2.2 ± 0.1</td> </tr> <tr> <th>D₀</th> <th>P₀</th> <th>P₁</th> <th>P₂</th> <th>T₂</th> </tr> <tr> <td style="text-align: center;">$\phi 1.5 \begin{smallmatrix} +0.1 \\ 0 \end{smallmatrix}$</td> <td style="text-align: center;">4.0 ± 0.1</td> <td style="text-align: center;">2.0 ± 0.1</td> <td style="text-align: center;">2.0 ± 0.05</td> <td style="text-align: center;">Max. 0.5</td> </tr> </tbody> </table>	W	F	E	A ₀	B ₀	8.0 ± 0.3	3.5 ± 0.05	1.75 ± 0.1	1.2 ± 0.1	2.2 ± 0.1	D ₀	P ₀	P ₁	P ₂	T ₂	$\phi 1.5 \begin{smallmatrix} +0.1 \\ 0 \end{smallmatrix}$	4.0 ± 0.1	2.0 ± 0.1	2.0 ± 0.05	Max. 0.5
A	B	C	D																										
$\phi 180 \begin{smallmatrix} 0 \\ -3 \end{smallmatrix}$	$\phi 60 \begin{smallmatrix} +1 \\ 0 \end{smallmatrix}$	$9 \begin{smallmatrix} +1.0 \\ 0 \end{smallmatrix}$	$\phi 13 \pm 0.2$																										
W	F	E	A ₀	B ₀																									
8.0 ± 0.3	3.5 ± 0.05	1.75 ± 0.1	1.2 ± 0.1	2.2 ± 0.1																									
D ₀	P ₀	P ₁	P ₂	T ₂																									
$\phi 1.5 \begin{smallmatrix} +0.1 \\ 0 \end{smallmatrix}$	4.0 ± 0.1	2.0 ± 0.1	2.0 ± 0.05	Max. 0.5																									

●Product designation

Part no.

M

N

R

0

4

M

0

A

B

J

Packaging / Processing specifications				Circuit configuration code	Resistance tolerance	Nominal resistance
Code	Part no.	Packaging	Package style	AB	J	3-digit IEC coding system
M0	MNR02 / 04	Taping	Paper tape with reel (10,000)	MNR04 / 12 / 14 / 32 / 34	±5%	