

Single Operational Amplifiers

TAA 762
TAA 765

Bipolar IC

Features

- Wide common-mode range
- Large supply voltage range
- Large control range
- Wide temperature range (TAA 762)
- High output frequency compensation
- Open collector output

Applications

- Amplifier
- Comparator
- Level converter
- Driver

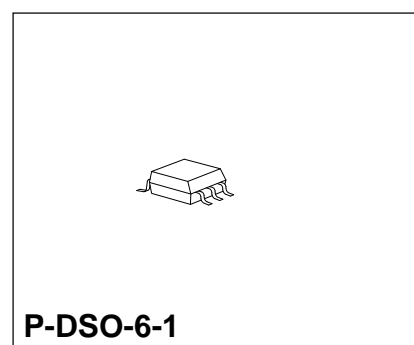
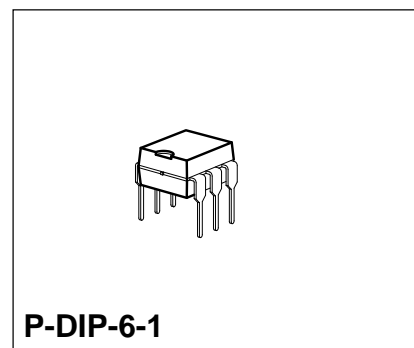

Type	Ordering Code	Package
TAA 762 A	Q67000-A2271	P-DIP-6-1
TAA 762 G	Q67000-A2273	P-DSO-6-1 (SMD)
TAA 765 A	Q67000-A524	P-DIP-6-1
TAA 765 G	Q67000-A599-G403	P-DSO-6-1 (SMD)

Particularly economic and versatile op amps. Owing to their excellent performance qualities they are well suited for a wide scope of applications, as in control engineering, automotive electronics, AF circuits, analog computers, etc.

Pin Configurations
(top view)

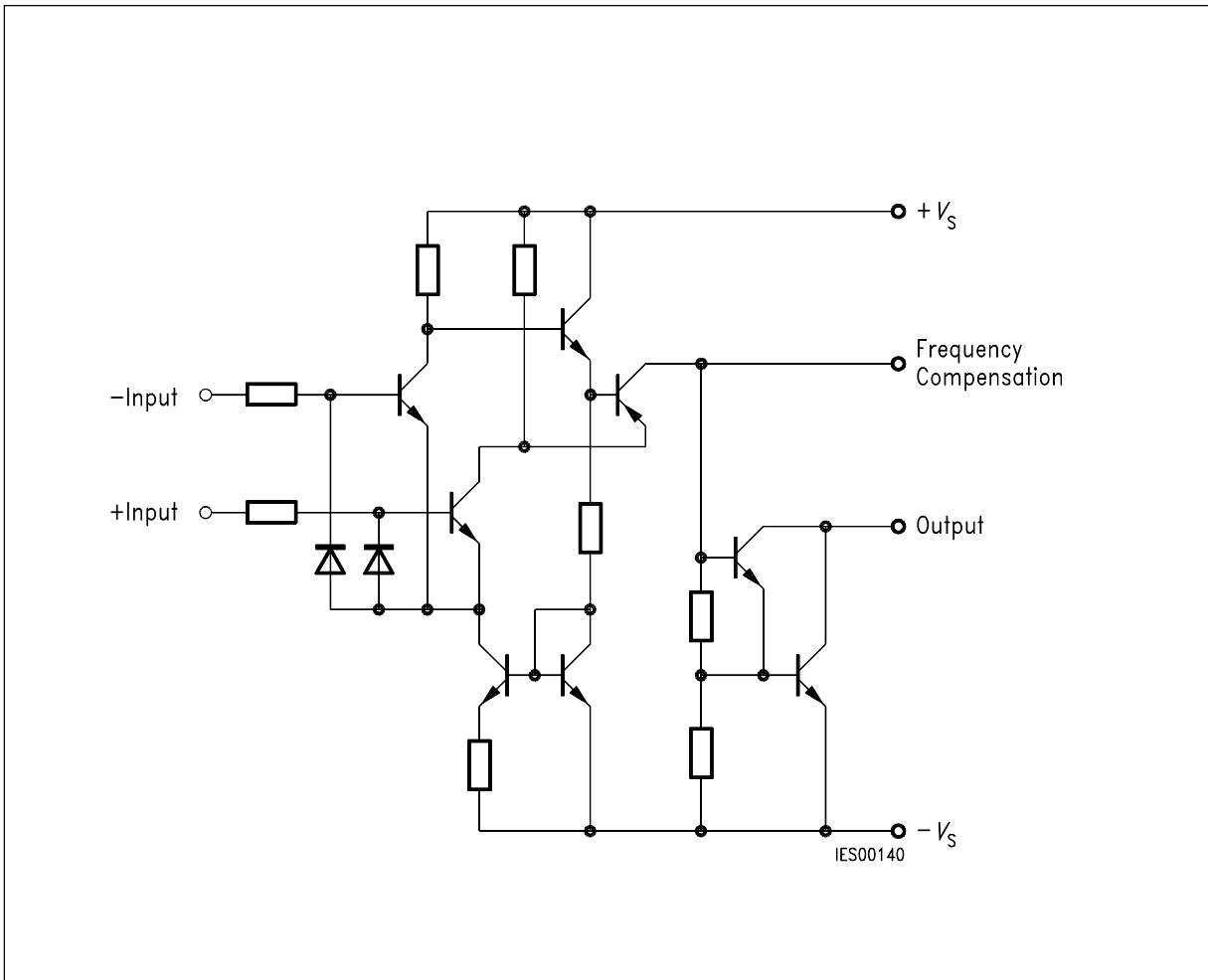
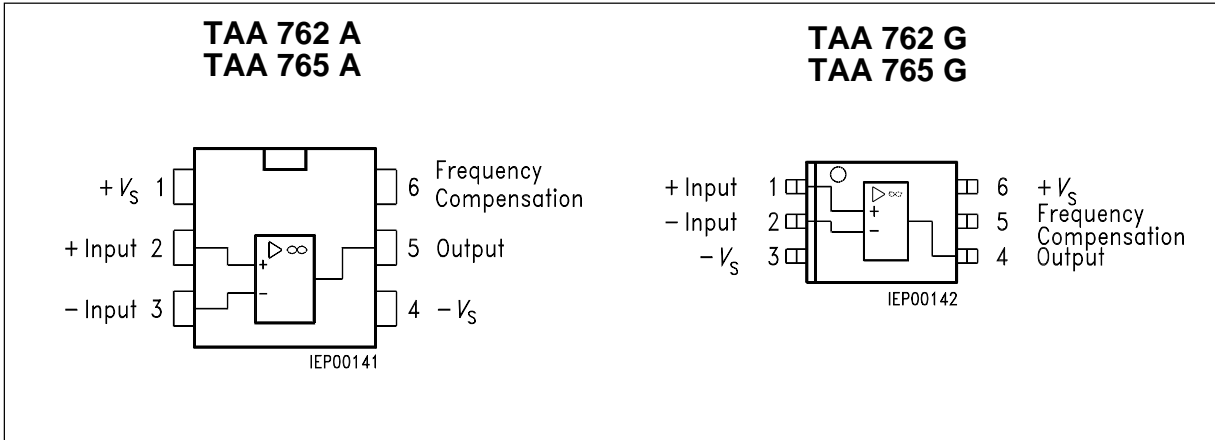

Circuit Diagram

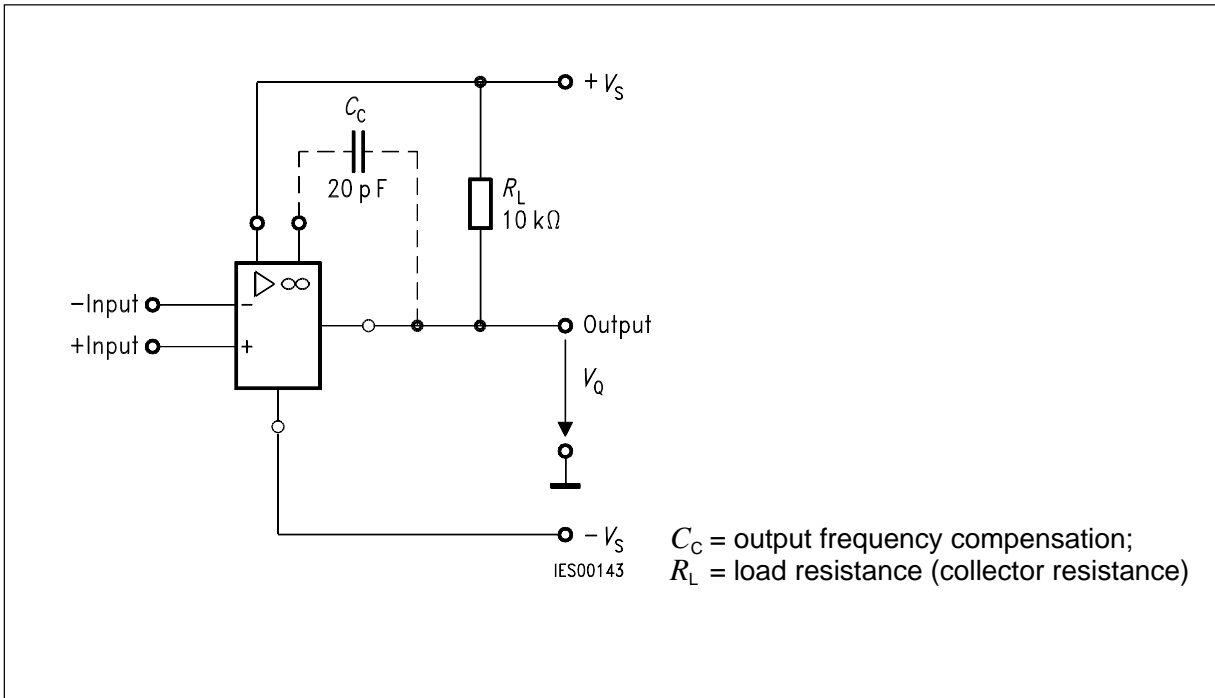

Connection Diagram

Absolute Maximum Ratings (TAA 762)

Parameter	Symbol	Limit Values	Unit	
Supply voltage	V_S	± 18	V	
Output current	I_Q	70	mA	
Differential input voltage	V_{ID}	$\pm V_S$	V	
Junction temperature	T_j	150	°C	
Storage temperature range	T_{stg}	- 55 to 125	°C	
Thermal resistance system - air	TAA 762 A TAA 762 G	$R_{th SA}$ $R_{th SA}$	115 200	K/W K/W

Operating Range (TAA 762)

Supply voltage	V_S	± 1.5 to ± 18	V
Ambient temperature	T_A	- 55 to 125	°C

Characteristics (TAA 762)

$V_S = \pm 5 \text{ V}$ to $\pm 15 \text{ V}$; $R_L = 2 \text{ k}\Omega$,
unless otherwise specified

Parameter	Symbol	Limit Values $T_A = 25 \text{ }^\circ\text{C}$			Limit Values $T_A = -55$ to $125 \text{ }^\circ\text{C}$		Unit
		min.	typ.	max.	min.	max.	
Open-loop supply current consumption	I_S		1.5	2.5		2.5	mA
Input offset voltage $R_G = 50 \text{ }\Omega$	V_{IO}	-4		4	-6	6	mV
Input offset current	I_{IO}	-100	± 50	100	-300	300	nA
Input current	I_I		0.3	0.7		1.0	μA
Control range $V_S = \pm 15 \text{ V}$	$V_{Q \text{ pp}}$	14.9		-14	14.8	-14	V
$R_L = 620 \text{ }\Omega$, $V_S = \pm 15 \text{ V}$	$V_{Q \text{ pp}}$	14.9		-12.5	14.8	-12	V
$V_S = \pm 15 \text{ V}$, $f = 100 \text{ kHz}$	$V_{Q \text{ pp}}$		± 10				V
Input impedance $f = 1 \text{ kHz}$	Z_I		200				$\text{k}\Omega$
Open-loop voltage gain $f = 1 \text{ kHz}$	G_{V0}	85	87		80		dB
$R_L = 10 \text{ k}\Omega$, $f = 1 \text{ kHz}$	G_{V0}		92				dB
$f = 1 \text{ MHz}$	G_{V0}		43				dB
Output reverse current	I_{QR}			1		5	μA
Common-mode input voltage range	V_{IC}	$-V_S + 2$		$V_S - 2$	$-V_S + 3$	$V_S - 3$	V
Common-mode rejection	k_{CMR}	80	85		75		dB
Supply voltage rejection $G_V = 100$	k_{SVR}		25	200		200	$\mu\text{V/V}$

Characteristics (TAA 762) (cont'd)

$V_S = \pm 5 \text{ V}$ to $\pm 15 \text{ V}$; $R_L = 2 \text{ k}\Omega$,
unless otherwise specified

Parameter	Symbol	Limit Values $T_A = 25 \text{ }^\circ\text{C}$			Limit Values $T_A = -55$ to $125 \text{ }^\circ\text{C}$		Unit
		min.	typ.	max.	min.	max.	
Temperature coefficient of V_{IO} $R_G = 50 \text{ }\Omega$	α_{VIO}		6	25		25	$\mu\text{V/K}$
Temperature coefficient of I_{IO} $R_G = 50 \text{ }\Omega$	α_{IIO}		0.3	1.5		1.5	nA/K
Slew rate of V_Q for non-inverting operation (test circuit 1)	SR		9				V/ μs
Slew rate of V_Q for inverting operation (test circuit 2)	SR		18				V/ μs
Noise voltage (in acc. with DIN 45 405; referred to input; $R_S = 2.5 \text{ k}\Omega$)	V_n		3				μV

Characteristics (TAA 762)

$V_S = \pm 2 \text{ V}$; $R_L = 2 \text{ k}\Omega$

Input offset voltage $R_G = 50 \text{ }\Omega$	V_{IO}	- 4		4	- 6	6	mV
Input offset current	I_{IO}	- 70		70	- 200	200	nA
Input current	I_I		0.2	0.5		0.8	μA
Open-loop voltage gain $f = 1 \text{ kHz}$	G_{V0}	80			75		dB

Absolute Maximum Ratings (TAA 765)

Parameter	Symbol	Limit Values	Unit
Supply voltage	V_S	± 18	V
Output current	I_Q	70	mA
Differential input voltage	V_{ID}	$\pm V_S$	V
Junction temperature	T_j	150	°C
Storage temperature range	T_{stg}	- 55 to 125	°C
Thermal resistance system - air	TAA 765 A TAA 765 G	$R_{th SA}$ $R_{th SA}$	115 200 K/W K/W

Operating Range (TAA 765)

Supply voltage	V_S	± 1.5 to ± 18	V
Ambient temperature	T_A	- 25 to 85	°C

Characteristics (TAA 765)

$V_S = \pm 5 \text{ V}$ to $\pm 15 \text{ V}$; $R_L = 2 \text{ k}\Omega$, unless otherwise specified

Parameter	Symbol	Limit Values $T_A = 25 \text{ }^\circ\text{C}$			Limit Values $T_A = -25$ to $85 \text{ }^\circ\text{C}$		Unit
		min.	typ.	max.	min.	max.	
Open-loop supply current consumption	I_S		1.5	2.5		2.5	mA
Input offset voltage $R_G = 50 \text{ }\Omega$	V_{IO}	- 5.5		5.5	- 7	7	mV
Input offset current	I_{IO}	- 200	± 80	200	- 300	300	nA
Input current	I_I		0.5	0.8		1.0	μA
Control range $V_S = \pm 15 \text{ V}$	$V_{Q\text{ pp}}$	14.9		- 14	14.8	- 14	V
$R_L = 620 \text{ }\Omega$, $V_S = \pm 15 \text{ V}$	$V_{Q\text{ pp}}$	14.9		- 12.5	14.8	- 12	V
$V_S = \pm 15 \text{ V}$, $f = 100 \text{ kHz}$	$V_{Q\text{ pp}}$		± 10				V
Input impedance $f = 1 \text{ kHz}$	Z_I		200				k Ω
Open-loop voltage gain $f = 1 \text{ kHz}$	G_{V0}	80	85		80		dB
$R_L = 10 \text{ k}\Omega$, $f = 1 \text{ kHz}$	G_{V0}		90				dB
$f = 1 \text{ MHz}$	G_{V0}		43				dB
Output reverse current	I_{QR}			10		20	μA
Common-mode input voltage range	V_{IC}	$-V_S + 2$		$V_S - 2$	$-V_S + 3$	$V_S - 3$	V
Common-mode rejection	k_{CMR}	75	83		75		dB
Supply voltage rejection $G_V = 100$	k_{SVR}		25	200		200	$\mu\text{V/V}$

Characteristics (TAA 765) (cont'd)

$V_S = \pm 5 \text{ V}$ to $\pm 15 \text{ V}$; $R_L = 2 \text{ k}\Omega$, unless otherwise specified

Parameter	Symbol	Limit Values $T_A = 25 \text{ }^\circ\text{C}$			Limit Values $T_A = -25$ to $85 \text{ }^\circ\text{C}$		Unit
		min.	typ.	max.	min.	max.	
Temperature coefficient of V_{IO} $R_G = 50 \text{ }\Omega$	α_{VIO}		6	25		25	$\mu\text{V/K}$
Temperature coefficient of I_{IO} $R_G = 50 \text{ }\Omega$	α_{VIO}		0.3	1.5		1.5	nA/K
Slew rate of V_Q for non-inverting operation (test circuit 1)	SR		9				V/ μs
Slew rate of V_Q for inverting operation (test circuit 2)	SR		18				V/ μs
Noise voltage (in acc. with DIN 45 405; referred to input; $R_S = 2.5 \text{ k}\Omega$)	V_n		3				μV

Characteristics (TAA 765)

$V_S = \pm 2 \text{ V}$; $R_L = 2 \text{ k}\Omega$

Input offset voltage $R_G = 30 \text{ }\Omega$	V_{IO}	- 6		6	- 7.5	7.5	mV
Input offset current	I_{IO}	- 150		150	- 200	200	nA
Input current	I_I		0.2	0.6		0.8	μA
Open-loop voltage gain $f = 1 \text{ kHz}$	G_{V0}	75			75		dB

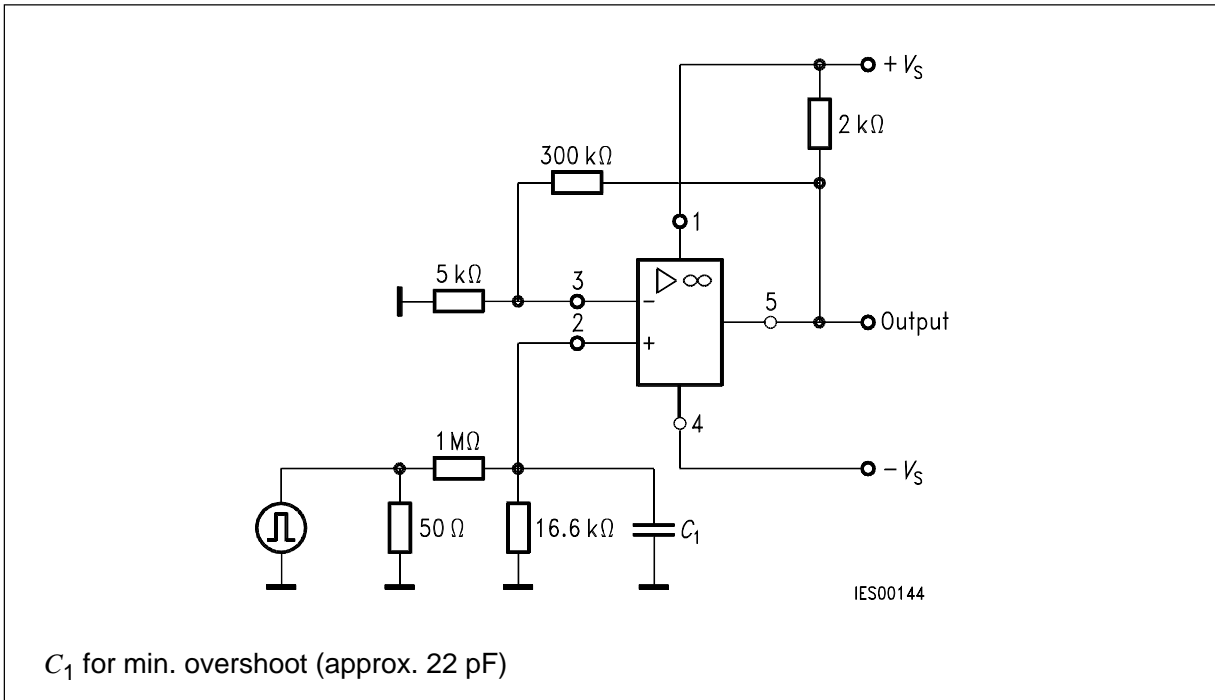

Test Circuit 1 for Slew Rate (non-inverting operation)

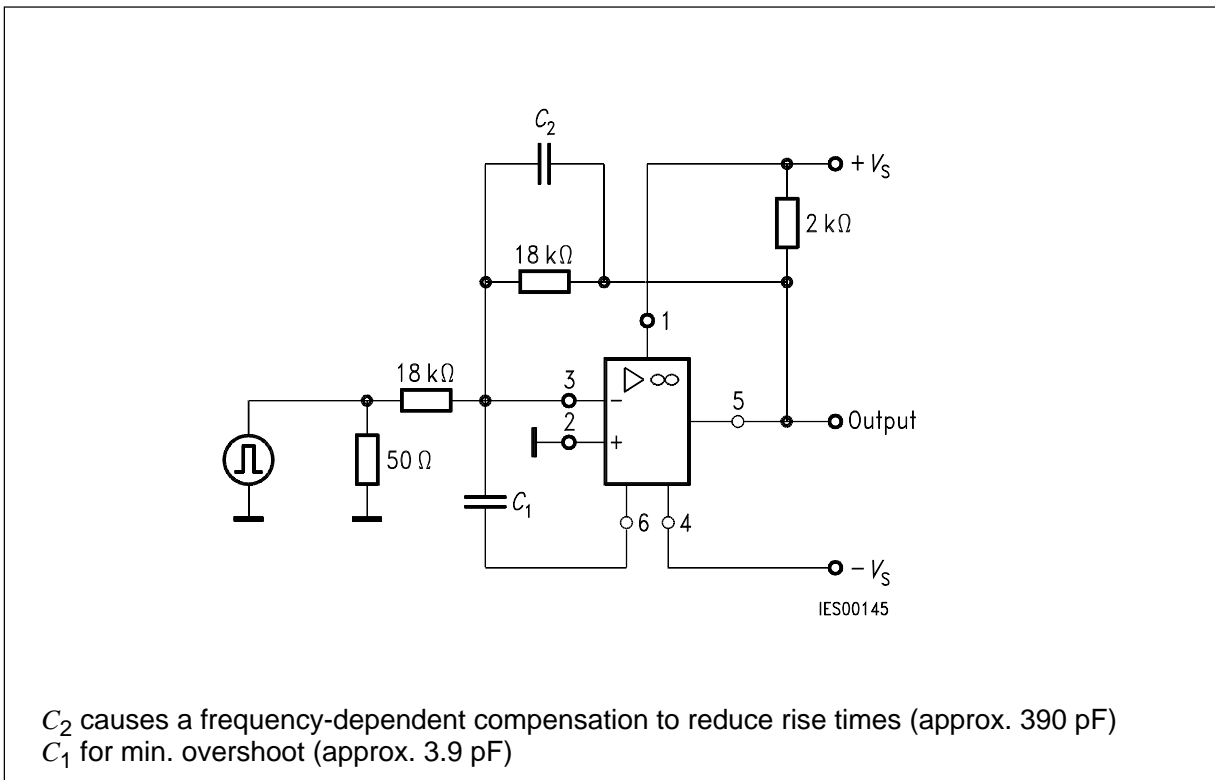

Test Circuit 2 for Slew Rate (inverting operation)

Transfer Characteristic
Output Voltage versus Input Voltage
 $V_S = \text{parameter}, R_L = 2 \text{ k}\Omega$

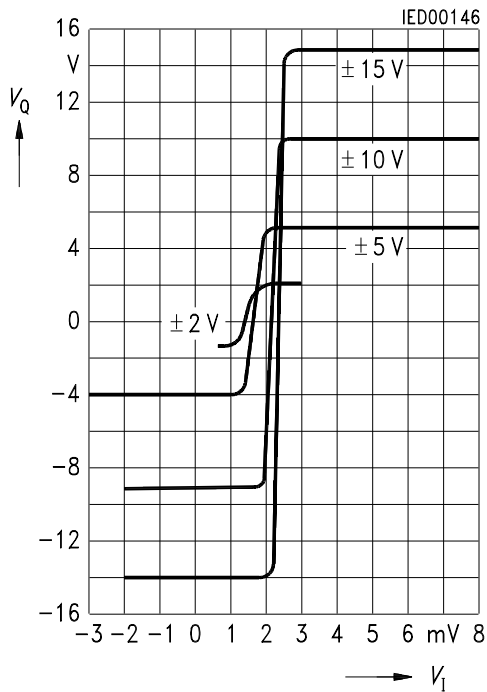

Saturation Voltage versus
Output Current
 $T_A = 25 \text{ }^\circ\text{C}$

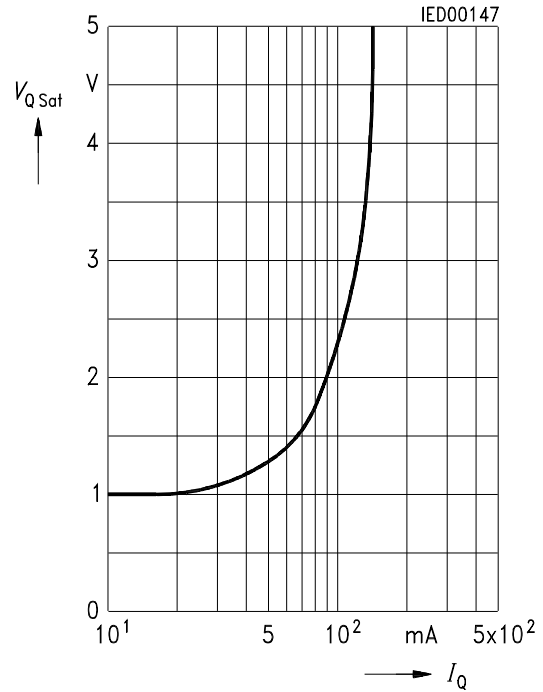

Open-Loop Voltage Gain and
Phase versus Frequency
 $V_S = \pm 15 \text{ V}; R_L = 2 \text{ k}\Omega$

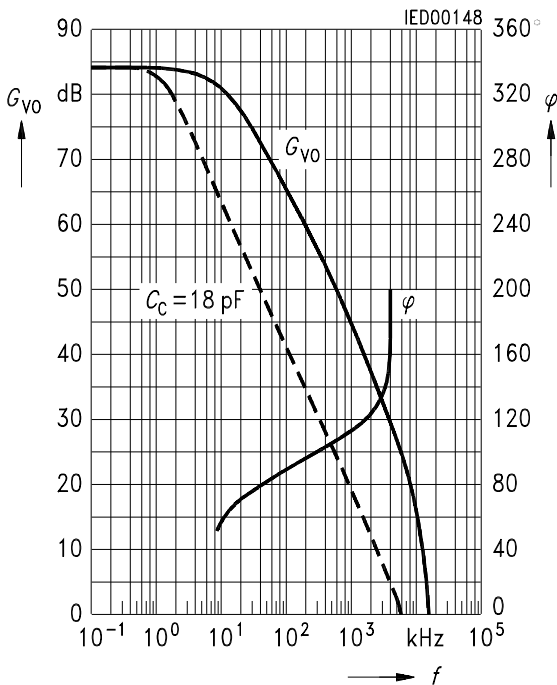

Frequency Dependence of Large
Signal Modulation Output Voltage
versus Frequency

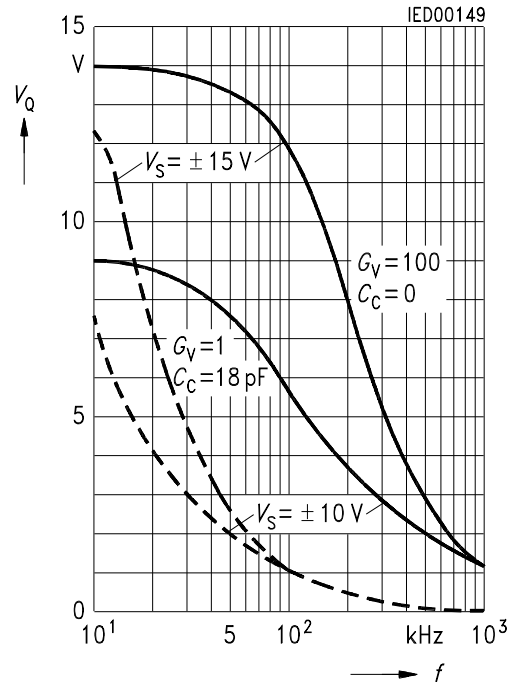

Transfer Characteristic
Output Voltage versus Input Voltage
 $V_S = \pm 15\text{ V}$; $R_L = \text{parameter}$

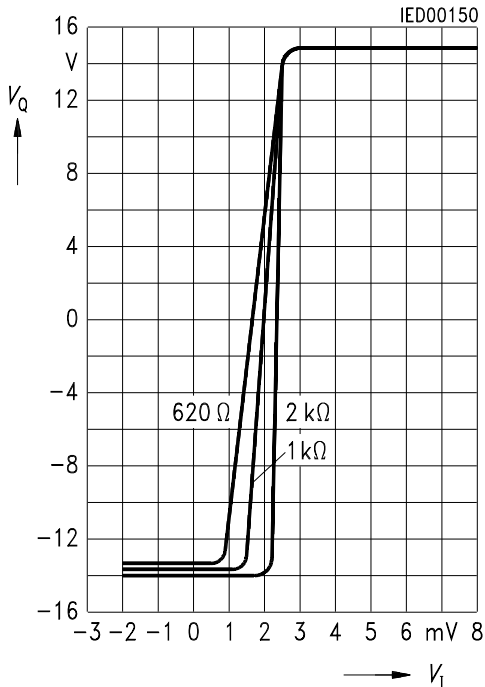

Common-Mode Voltage Range
Common-Mode Input
Voltage versus Supply Voltage

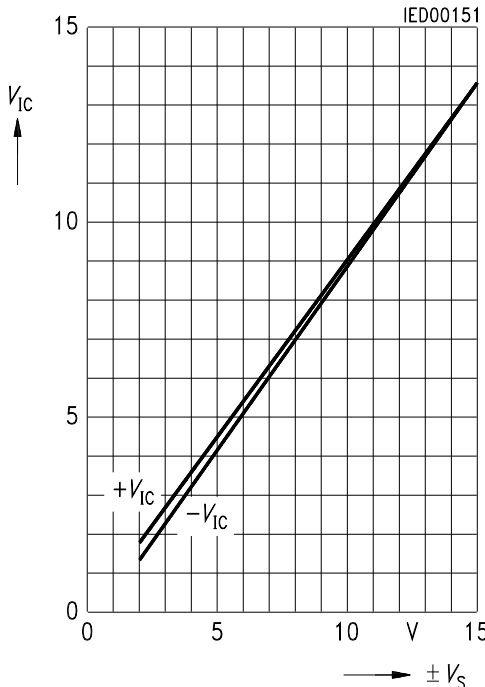

Open-Loop Voltage Gain versus Supply Voltage

$T_A = 25\text{ }^\circ\text{C}$, $R_L = 2\text{ k}\Omega$

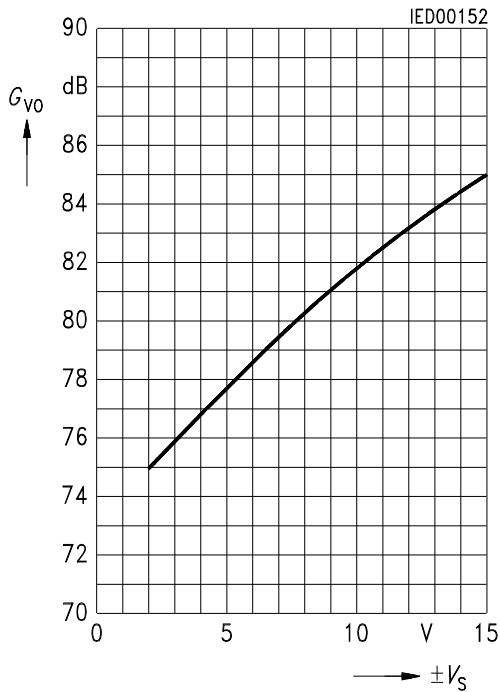

Input Current versus Supply Voltage

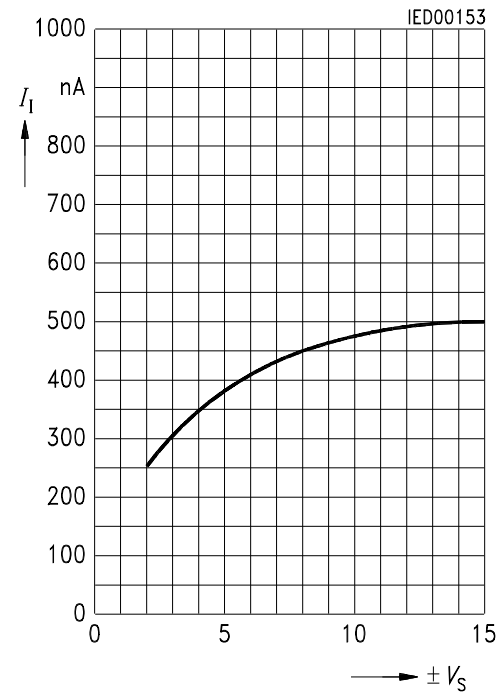

Open-Loop Voltage Gain versus Load Resistance

$T_A = 25\text{ }^\circ\text{C}$

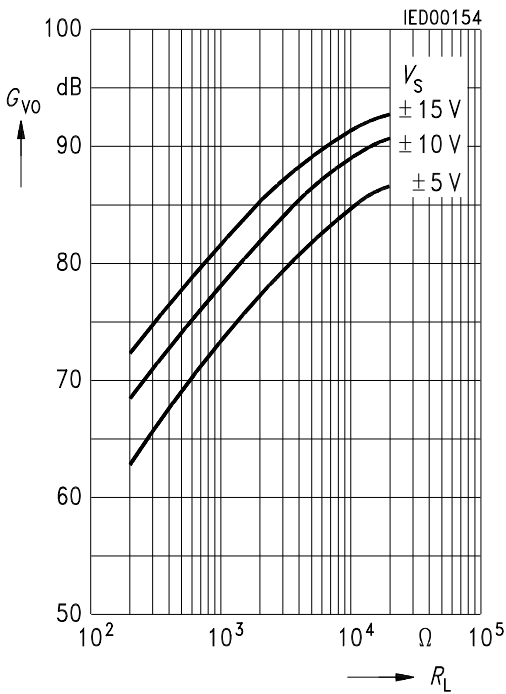

Input Offset Voltage versus Load Resistance

$V_S = \pm 15\text{ V}$

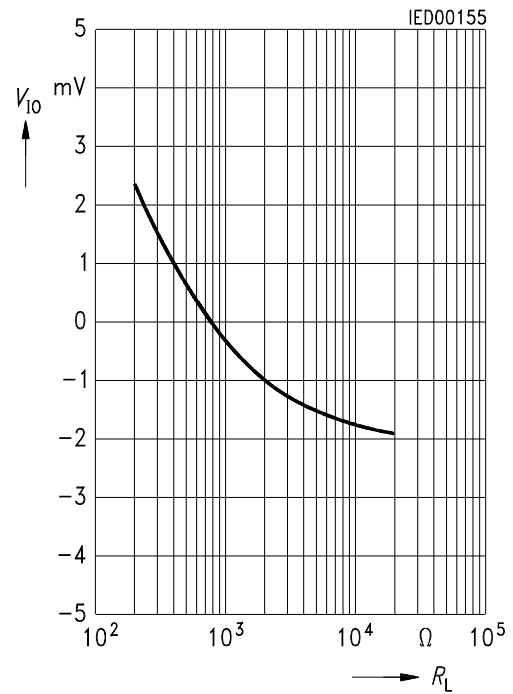

Input Offset Voltage versus Ambient Temperature
 $R_L = 2 \text{ k}\Omega$; $V_S = \pm 15 \text{ V}$

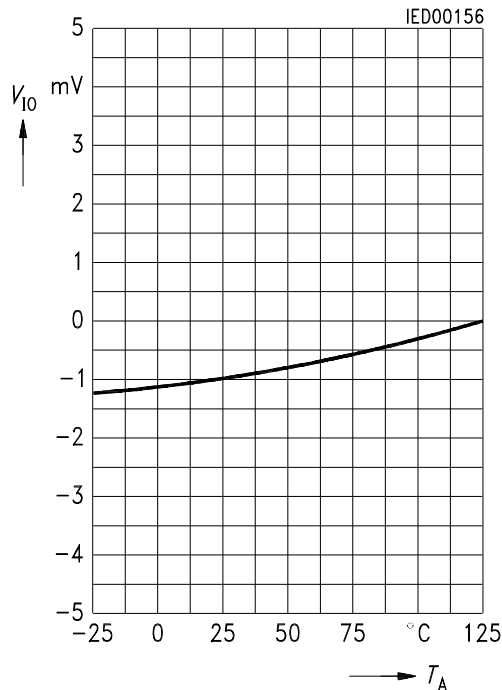

Input Offset Current versus Ambient Temperature
 $R_L = 2 \text{ k}\Omega$; $V_S = \pm 15 \text{ V}$

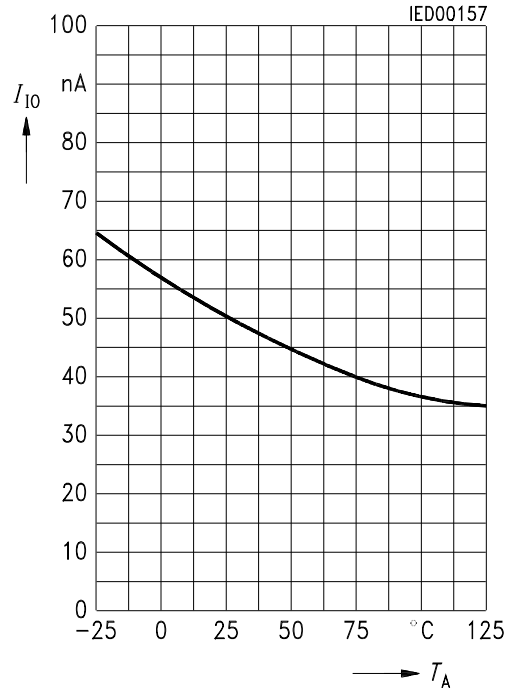

Input Current versus Ambient Temperature
 $R_L = 2 \text{ k}\Omega$

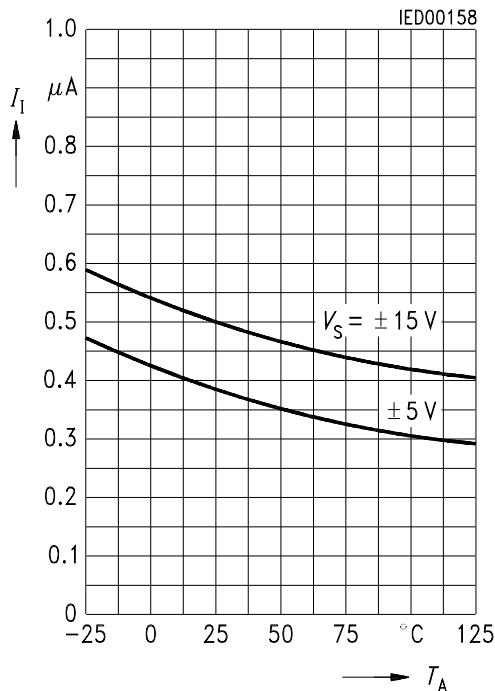

Open-Loop Voltage Gain versus Ambient Temperature
 $R_L = 2 \text{ k}\Omega$; $f = 1 \text{ kHz}$

