

# 35.0-45.0 GHz GaAs Receiver SMT, 7x7 mm

## Features

- X Sub-harmonic, Image Reject Receiver
- X Integrated LNA, Image Reject Mixer, LO Doubler/Buffer
- X +2.0 dBm LO Drive Level
- X 10.0 dB Conversion Gain
- X 3.5 dB NF
- X +5.0 dBm Input Third Order Intercept (IIP3)
- X 7x7mm SMT package
- X 100% RF and DC Testing



## General Description

Mimix Broadband's 35.0-45.0 GHz packaged receiver has a noise figure of 3.5 dB and 5.0 dBm Input Third Order Intercept across the band. This device integrates a three stage LNA followed by an image reject resistive pHEMT mixer and includes an integrated LO doubler and buffer amplifier. The use of integrated LO doubler and LO buffer amplifier makes the provision of the LO easier than for fundamental mixers at these frequencies. I and Q mixer outputs are provided and an external 90 degree hybrid is required to select the desired sideband. The device comes in a 7x7mm SMT package that is RoHS compliant. This device has been designed for use in 38/42 GHz Point-to-Point Microwave Radio applications.

## Absolute Maximum Ratings

Supply Voltage (Vd)	+4.3 VDC
Supply Current (Id)	300 mA
Gate Bias Voltage (Vg)	-1.5V < Vg < 0V
Input Power (Pin)	+5 dBm
Storage Temperature (Tstg)	-65 to +165 °C
Operating Temperature (Ta)	-55 to +85 °C
Channel Temperature (Tch)	175 °C
ESD - Human Body Model	Class 1A
ESD - Machine Body Model	Class A
Moisture Sensitivity Level	MSL3

(1) Channel temperature affects a device's MTTF. It is recommended to keep channel temperature as low as possible for maximum life

## Electrical Characteristics (Ambient Temperature T = 25° C)

Parameter	Units	Min.	Typ.	Max.
Frequency Range (RF)	GHz	35.0	-	45.0
Frequency Range (LO)	GHz	16.0	-	24.0
Frequency Range (IF)	GHz	DC	-	4.0
Input Return Loss (S11)	dB	-	10.0	-
Conversion Gain RF/IF (S21) (LSB/USB) [IF=2 GHz] <sup>1</sup>	dB	8.0/9.5	9.0/10.0	-
Conversion Gain RF/IF (S21) (LSB/USB) [IF=3.5 GHz] <sup>1</sup>	dB	6.8/8.3	7.8/8.8	-
LO Input Drive (Plo)	dBm	0.0	+2.0	+8.0
Image Rejection [IF=2 GHz] <sup>1</sup>	dBc	15.0	-	-
Image Rejection [IF=3.5 GHz] <sup>1</sup>	dBc	13.0	-	-
Noise Figure (NF) (LSB/USB) [IF=2 GHz] <sup>1</sup>	dB	-	3.5/3.5	4.6/4.3
Noise Figure (NF) (LSB/USB) [IF=3.5 GHz] <sup>1</sup>	dB	-	4.0/4.0	5.1/4.8
Isolation LO/RF @ LOx1/LOx2	dB	-	40.0/40.0	-
Input Third Order Intercept Point (IIP3) <sup>1</sup>	dBm	0.0	+5.0	-
Input 1 dB Compression (IP1dB)	dBm	-	-5.0	-
Drain Bias Voltage (Vd)	VDC	-	4.0	4.0
Gate Bias Voltage (Vg1,2)	VDC	-1.0	-0.5	-0.1
Supply Current (Id) (Vd=4.0, Vg=-0.5V Typical)	mA	-	180	240

(1) Performance limits guaranteed over the frequency range 37.0-40.0 GHz

# 35.0-45.0 GHz GaAs Receiver SMT, 7x7 mm

July 2010 - Rev 23-Jul-10

## Measurements

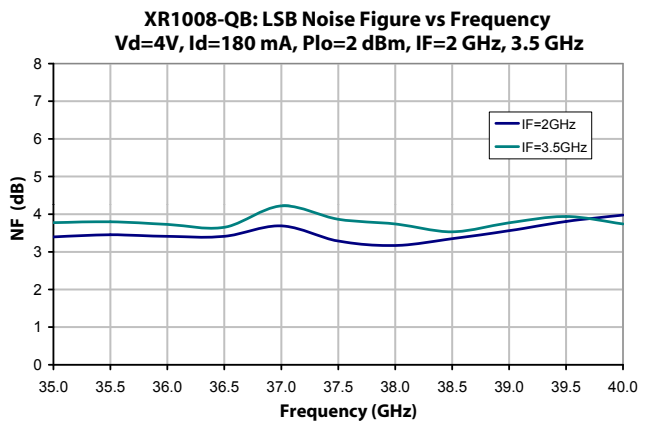
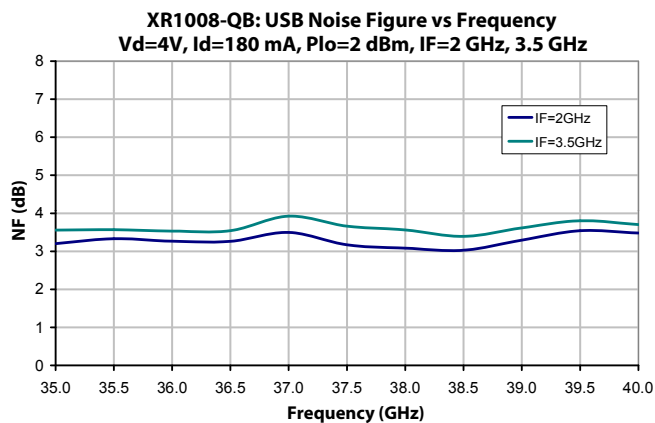
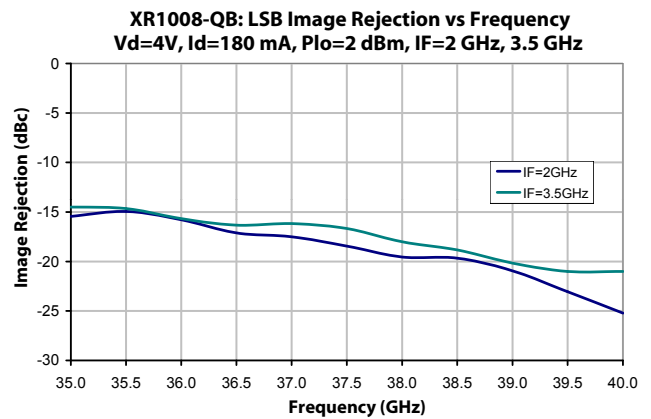
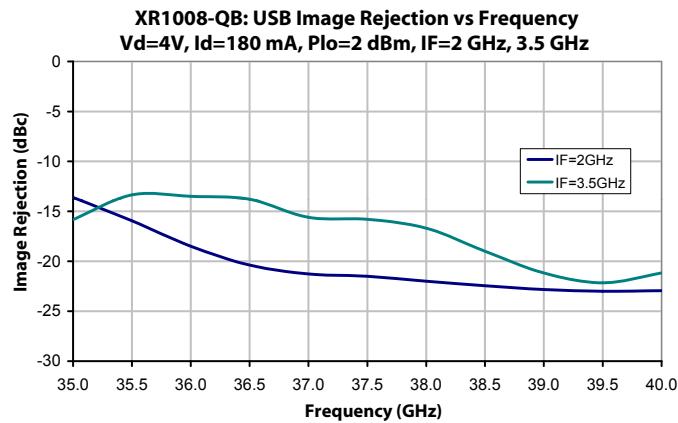
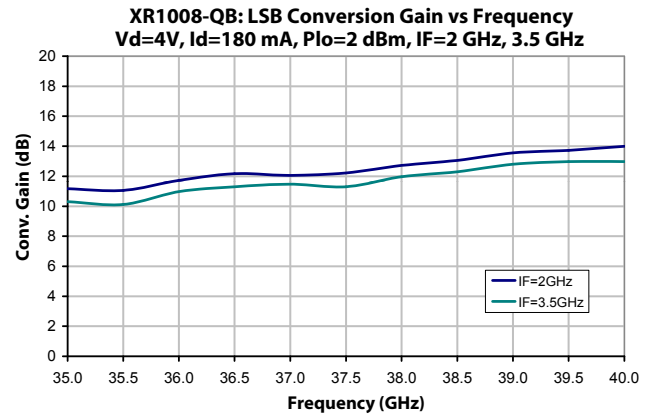
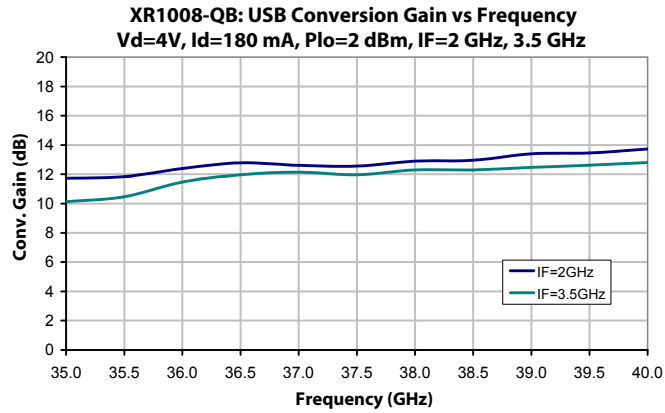

# 35.0-45.0 GHz GaAs Receiver SMT, 7x7 mm

July 2010 - Rev 23-Jul-10

## Measurements (cont.)

XR1008-QB: USB Conv. Gain and Image Rej. vs Freq.  
Vd=4V, Id=180 mA, P\_LO=+2 dBm

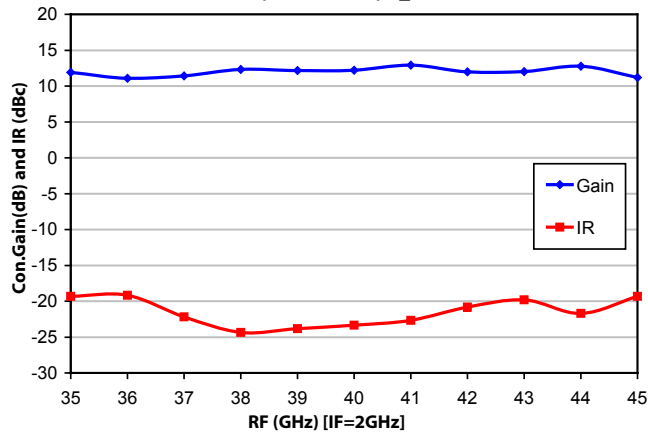

XR1008-QB: LSB Conv. Gain and Image Rej. vs Freq.  
Vd=4V, Id=180 mA, P\_LO=+2 dBm

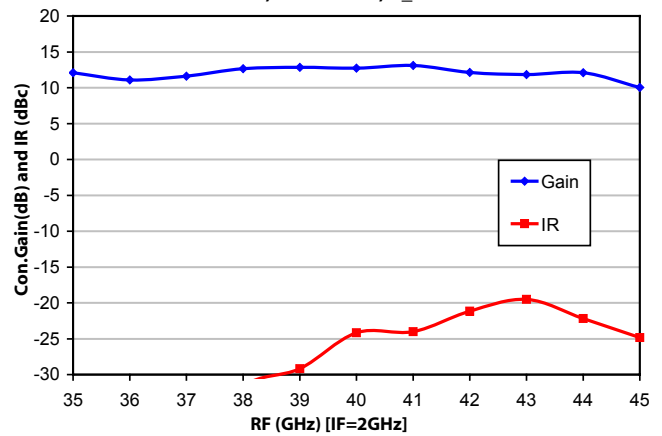

# 35.0-45.0 GHz GaAs Receiver

## SMT, 7x7 mm

### Physical Dimensions

#### QB - MSL, Gross Leak Test Compliant

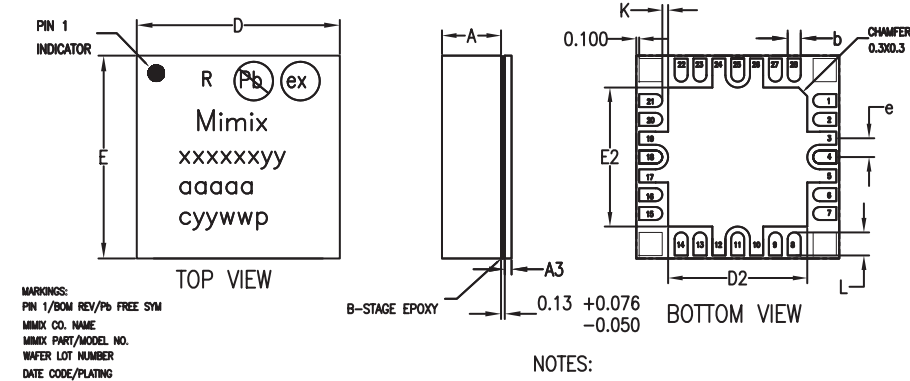

#### RECOMMENDED SOLDER PAD PITCH AND DIMENSIONS

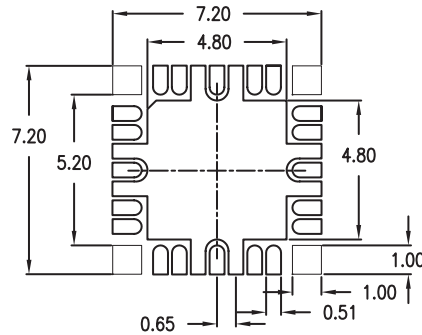

	MIN	TYP	MAX
A	1.20	1.25	1.30
A3	0.10 - 0.20		REF
b	0.40	0.45	0.50
K	-	0.20	-
D	7.00 BSC		
E	7.00 BSC		
e	0.65		
D2	4.75	4.80	4.85
E2	4.75	4.80	4.85
L	0.75	0.80	0.85

1. VIEWS ARE NOT TO SCALE: USE DIMENSIONS AND TABLE.

(Note: Engineering designator is 40REC0770)

### Functional Schematic

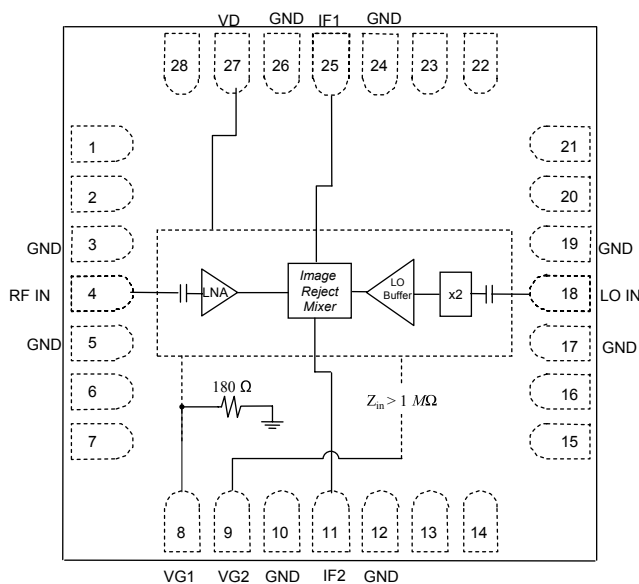

### Pin Designations

Pin Number	Pin Name	Pin Function	Nominal Value	Remarks
3	GND	Ground		
4	RF IN	RF Input		
5	GND	Ground		
8	VG1	LNA, LO Amp	-0.5 V	Adjust VG1 for drain current (Id) = 180 mA. VG1 has an input impedance of 180 Ω.
9	VG2	Mixer, Doubler	-0.5 V	VG2 requires a fixed voltage and has a high input impedance > 1 MΩ
10	GND	Ground		
11	IF2	IF2 Output		
12	GND	Ground		
17	GND	Ground		
18	LO IN	LO Input	+ 2 dBm	
19	GND	Ground		
24	GND	Ground		
25	IF1	IF1 Output		
26	GND	Ground		
27	VD	Drain Bias	+ 4.0 V	
All other pins	NC	Not Connected		

# 35.0-45.0 GHz GaAs Receiver SMT, 7x7 mm

July 2010 - Rev 23-Jul-10

## Recommended Layout

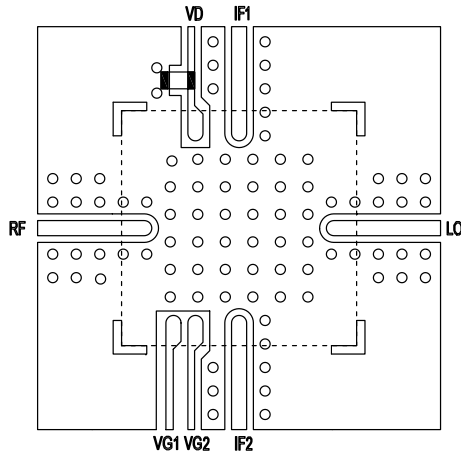

**App Note [1] Biasing** - Please refer to the functional block diagram and pin-out table for biasing information. The device is operated by biasing  $V_D=4.0V$  with  $I_D=180\text{ mA}$  by adjusting the applied voltage on  $V_{G1}$ .  $V_{G1}$  typically requires  $-0.5V$  to result in the drain current being  $180\text{mA}$ . The nominal input impedance of this gate is  $180\Omega$ , so it should be noted that the nominal gate current will be  $2.7\text{mA}$ .

Additionally, a fixed bias of  $V_{G2}=-0.5V$  is required to bias the mixer and doubler. Adjusting  $V_{G2}$  above or below this value can adversely affect conversion gain, image rejection and intercept point performance. It is recommended to use active biasing to keep the currents constant as the RF power and temperature vary; this gives the most reproducible results. The diagram "Active Bias Circuit" demonstrates a possible method for active biasing. Depending on the supply voltage available and the power dissipation constraints, the bias circuit may be a single transistor or a low power operational amplifier, with a low value resistor in series with the drain supply used to sense the current. The gate of the pHEMT is controlled to maintain correct drain current and thus drain voltage. Typically the gate is protected with Silicon diodes to limit the applied voltage. Also, make sure to sequence the applied voltage to ensure negative gate bias is available before applying the positive drain supply

## Active Bias Circuit

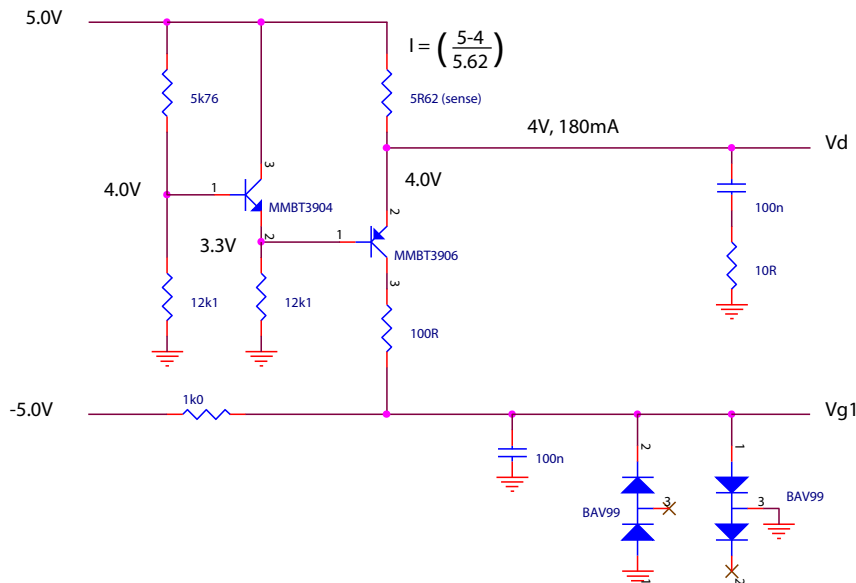

# 35.0-45.0 GHz GaAs Receiver SMT, 7x7 mm

July 2010 - Rev 23-Jul-10

## MTTF

MTTF is calculated from accelerated life-time data of single devices and assumes an isothermal back-plate.

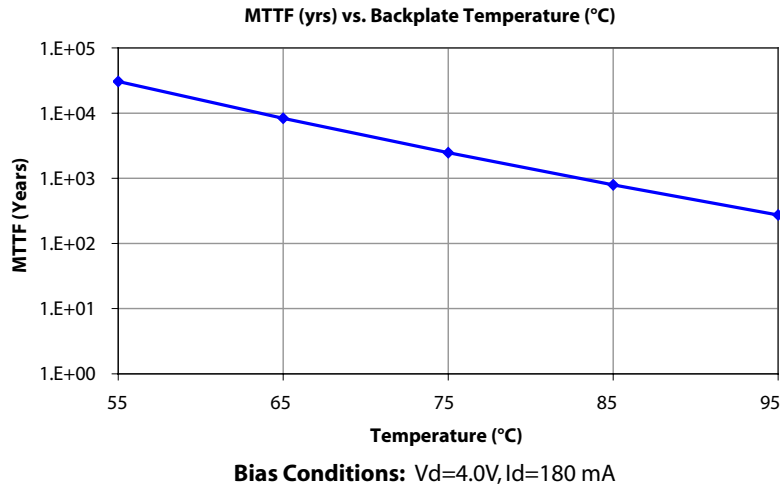

## Typical Application

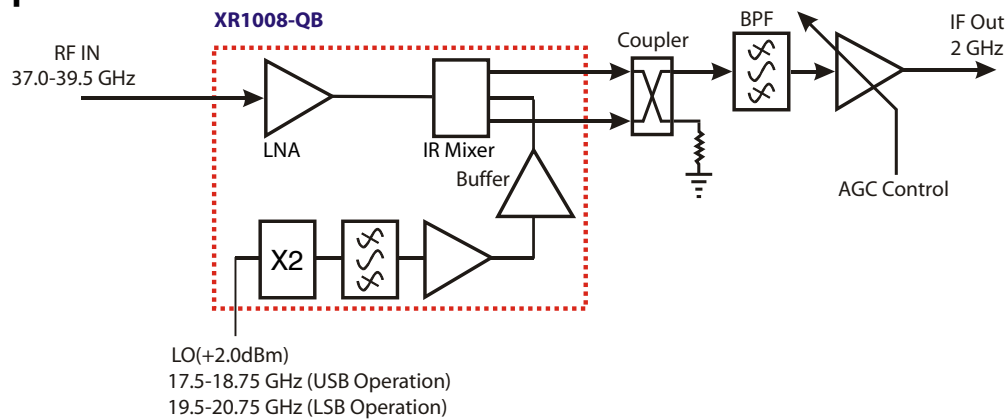

### Mimix Broadband MMIC-based 35.0-45.0 GHz Receiver Block Diagram

(Changing LO and IF frequencies as required allows design to operate as high as 46 GHz)

Mimix Broadband's 30.0-46.0 GHz XR1008-QB GaAs MMIC Receiver can be used in saturated radio applications and linear modulation schemes up to 128 QAM.

# 35.0-45.0 GHz GaAs Receiver SMT, 7x7 mm

## App Note [3] USB/LSB Selection -

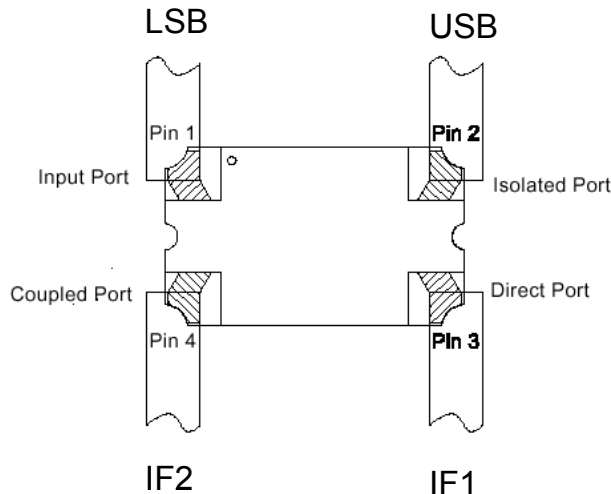

### For Upper Side Band operation (USB):

With IF1 and IF2 connected to the direct port (0°) and coupled port (90°) respectively as shown in the diagram, the USB signal will reside on the isolated port. The input port must be loaded with 50 ohms.

### For Lower Side Band operation (LSB):

With IF1 and IF2 connected to the direct port (0°) and coupled port (90°) respectively as shown in the diagram, the LSB signal will reside on the input port. The isolated port must be loaded with 50 ohms.

An alternate method of Selection of USB or LSB:

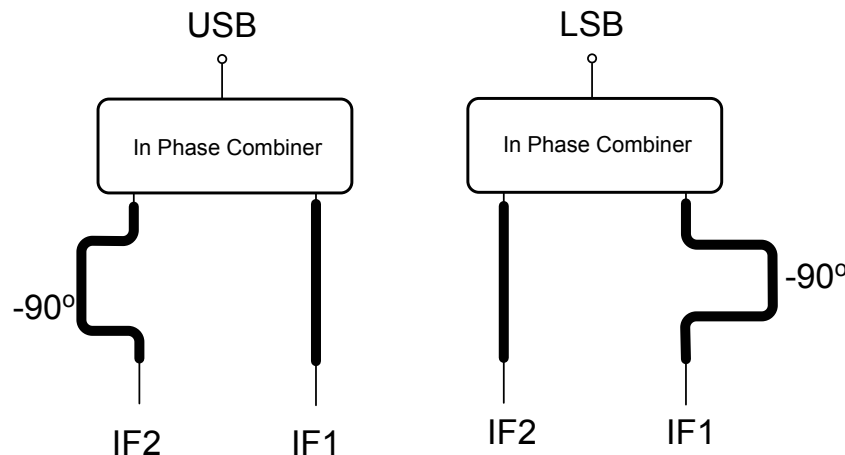

## Factory Automation and Identification

Mimix Designator	Package Type	Number of leads offered	W Tape Width	P <sub>1</sub> Component Pitch	P <sub>0</sub> Hole Pitch	Reel Diameter	Units per Reel
-QB	QFN (7x7mm)	28	16mm	12mm	4mm	329mm (13in)	1000

### Tape and Reel Packaging per the following conditions:

Tape Width: 16 mm  
 Tape Pitch (part to part): 12 mm  
 Component Orientation: Parts are to be oriented with the PIN 1 closest to the tape's round sprocket holes on the tape's trailing edge.  
 Reel Diameter: 329 mm (13 inch)

Note: Tape and Reel packaging is ordered with a -000T suffix. Package is available in 500 unit reels through designated sales channels. Minimum order quantities should be discussed with your local sales representative.

# 35.0-45.0 GHz GaAs Receiver SMT, 7x7 mm

July 2010 - Rev 23-Jul-10

## Handling and Assembly Information

**CAUTION!** - Mimix Broadband MMIC Products contain gallium arsenide (GaAs) which can be hazardous to the human body and the environment. For safety, observe the following procedures:

- Do not ingest.
- Do not alter the form of this product into a gas, powder, or liquid through burning, crushing, or chemical processing as these by-products are dangerous to the human body if inhaled, ingested, or swallowed.
- Observe government laws and company regulations when discarding this product. This product must be discarded in accordance with methods specified by applicable hazardous waste procedures.

**Life Support Policy** - Mimix Broadband's products are not authorized for use as critical components in life support devices or systems without the express written approval of the President and General Counsel of Mimix Broadband. As used herein: (1) Life support devices or systems are devices or systems which, (a) are intended for surgical implant into the body, or (b) support or sustain life, and whose failure to perform when properly used in accordance with instructions for use provided in the labeling, can be reasonably expected to result in a significant injury to the user. (2) A critical component is any component of a life support device or system whose failure to perform can be reasonably expected to cause the failure of the life support device or system, or to affect its safety or effectiveness.

**Package Attachment** - This packaged product from Mimix Broadband is provided as a rugged surface mount package compatible with high volume solder installation. The package is a low-cost plastic package. Vacuum tools or other suitable pick and place equipment may be used to pick and place this part. Care should be taken to ensure that there are no voids or gaps in the solder connection so that good RF, DC and ground connections are maintained. Voids or gaps can eventually lead not only to RF performance degradation, but reduced reliability and life of the product due to thermal stress.

### Typical Reflow Profiles

Reflow Profile	SnPb	Pb Free
Ramp Up Rate	3-4 °C/sec	3-4 °C/sec
Activation Time and Temperature	60-120 sec @ 140-160 °C	60-180 sec @ 170-200 °C
Time Above Melting Point	60-150 sec	60-150 sec
Max Peak Temperature	240 °C	265 °C
Time Within 5 °C of Peak	10-20 sec	10-20 sec
Ramp Down Rate	4-6 °C/sec	4-6 °C/sec

**Mimix Lead-Free RoHS Compliant Program** - Mimix has an active program in place to meet customer and governmental requirements for eliminating lead (Pb) and other environmentally hazardous materials from our products. All Mimix RoHS compliant components are form, fit and functional replacements for their non-RoHS equivalents. Lead plating of our RoHS compliant parts is 100% matte tin (Sn) over copper alloy and is backwards compatible with current standard SnPb low-temperature reflow processes as well as higher temperature (260°C reflow) "Pb Free" processes.

## Ordering Information

Part Number for Ordering	Description
XR1008-QB-0N00	Ni/Au plated RoHS compliant 7x7 28L surface mount package in bulk quantity
XR1008-QB-0N0T	Ni/Au plated RoHS compliant 7x7 28L surface mount package in tape and reel
XR1008-QB -EV1	XR1008-QB evaluation board

We also offer this part with alternative plating options. Please contact your regional sales manager for more information regarding different plating types.



Proper ESD procedures should be followed when handling this device.

Mimix Broadband, Inc., 10795 Rockley Rd., Houston, Texas 77099  
Tel: 281.988.4600 Fax: 281.988.4615 mimixbroadband.com

Page 8 of 8

Characteristic Data and Specifications are subject to change without notice. ©2010 Mimix Broadband, Inc.  
Export of this item may require appropriate export licensing from the U.S. Government. In purchasing these parts, U.S. Domestic customers accept their obligation to be compliant with U.S. Export Laws.