

### The New-generation General-purpose Relay

- Reliable and unique test button models now available.
- High switching capacity (1-pole: 10 A)
- Highly functional socket also available.
- Space-saving (29 (H) x 13 (W) x 29 (D))
- Conforms to UL508, CSA22.2, VDE0435 (C250 insulation grade).
- 8-mm creepage distance / 8-mm air distance

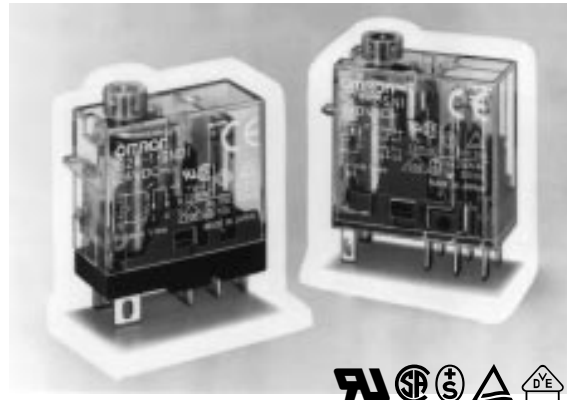

### Ordering Information

Classification		Degree of protection	Coil ratings	Contact form			
				SPST-NO	SPDT	DPST-NO	DPDT
Plug-in terminal	General-purpose	Unsealed	AC/DC	---	G2R-1-S	---	G2R-2-S
	LED indicator			---	G2R-1-SN	---	G2R-2-SN
	LED indicator with test button			---	G2R-1-SNI	---	G2R-2-SNI
	Diode		DC	---	G2R-1-SD	---	G2R-2-SD
	LED indicator and diode			---	G2R-1-SND	---	G2R-2-SND
	LED indicator and diode with test button			---	G2R-2-SNDI	---	G2R-2-SNDI
Plug-in terminal (Twin crossbar contact)	General-purpose		AC/DC	G2R-1A3-S	G2R-13-S	---	---
	LED indicator			G2R-1A3-SN	G2R-13-SN	---	---
	LED indicator and diode		DC	G2R-1A3-SND	G2R-13-SND	---	---

**Note:** When ordering, add the rated coil voltage to the model number.

Example: G2R-1A 12 VDC

Rated coil voltage

#### Model Number Legend:

G2R   -       -     -  

1    2    3    4    5    6    7

1. **Relay Function**  
None: General-purpose
2. **Number of Poles**  
1: 1 pole  
2: 2 poles
3. **Contact Form**  
None: SPDT  
A: SPST-NO

4. **Contact Type**  
None: Single  
3: Bifurcated crossbar
5. **Terminals**  
S: Plug-in

6. **Classification**  
None: General-purpose  
N: LED indicator  
D: Diode  
ND: LED indicator and diode  
I: Test button

7. **Rated Coil Voltage**

## ■ Accessories (Order Separately)

### Connecting Sockets

Number of poles	Applicable relay model	Track/surface mounting socket	Back mounting socket	
			Terminals	Model
1 pole	G2R-1-S(N)(D)(ND)(NI)(NDI) G2R-13-S (G2R-1A3-S)	P2RF-05-E P2RF-05	PCB terminals	P2R-05P, P2R-057P
			Solder terminals	P2R-05A
2 poles	G2R-2-S(N)(D)(ND)(NI)(NDI)	P2RF-08-E P2RF-08	PCB terminals	P2R-08P, P2R-087P
			Solder terminals	P2R-08A

Note: See *Dimensions* for details on socket size.

### Mounting Tracks

Applicable socket	Description	Model
Track connecting socket	Mounting track	50 cm (ℓ) x 7.3 mm (t): PFP-50N 1 m (ℓ) x 7.3 mm (t): PFP-100N 1 m (ℓ) x 16 mm (t): PFP-100N2
	End plate	PFP-M
	Spacer	PFP-S
Back connecting socket	Mounting plate	P2R-P*

\*Used to mount several P2R-05A and P2R-08A Connecting Sockets side by side.

## Specifications

### ■ Coil Ratings

Rated voltage		12 VAC	24 VAC	100/ (110) VAC	120 VAC	200/ (220) VAC	220 VAC	230 VAC	240 VAC
Rated current*	50 Hz	93 mA	46.5 mA	11 mA	9.3 mA	5.5 (4.0) mA	5.1 mA	4.7 (3.7) mA	4.7 mA
	60 Hz	75 mA	37.5 mA	9/ (10.6) mA	7.5 mA	4.5 (5.3) mA	4.1 mA	3.8 (3.1) mA	3.8 mA
Coil resistance*		65 Ω	260 Ω	4,600 Ω	6,500 Ω	20,200 (25,000) Ω	25,000 Ω	26,850 (30,000) Ω	30,000 Ω
Coil inductance (H) (ref. value)	Armature OFF	0.19	0.81	13.34	21	51.3	57.5	62	65.5
	Armature ON	0.39	1.55	26.84	42	102	117	124	131
Must operate voltage		80% max. of rated voltage							
Must release voltage		30% max. of rated voltage							
Max. voltage		110% of rated voltage							
Power consumption		Approx. 0.9 VA at 60 Hz (approx. 0.7 VA at 60 Hz)							

Note: 1. Rated voltage of bifurcated crossbar contact type: 100/(110) VAC, 200/(220) VAC, 230 VAC (Approx. 0.7 VA at 60 Hz)  
2. Depending on the type of Relay, Some Relays do not have coil specifications. Contact your OMRON representative for more details.

Rated voltage		5 VDC	6 VDC	12 VDC	24 VDC	48 VDC	100 VDC
Rated current* (50/60 Hz)		106 mA	88.2 mA	43.6 mA	21.8 mA	11.5 mA	5.3 mA
Coil resistance*		47 Ω	68 Ω	275 Ω	1,100 Ω	4,170 Ω	18,860 Ω
Coil inductance (H) (ref. value)	Armature OFF	0.20	0.28	1.15	4.27	13.86	67.2
	Armature ON	0.39	0.55	2.29	8.55	27.71	93.2
Must operate voltage		70% max. of rated voltage					
Must release voltage		15% min. of rated voltage					
Max. voltage		110% of rated voltage					
Power consumption		Approx. 0.53 W					

Note: Rated voltage of bifurcated crossbar contact type: 12 VDC, 24 VDC

## ■ Contact Ratings

### Plug-in Terminal Relays

Number of poles	1 pole		2 poles	
Load	Resistive load ( $\cos\phi = 1$ )	Inductive load ( $\cos\phi = 0.4$ ; L/R = 7 ms)	Resistive load ( $\cos\phi = 1$ )	Inductive load ( $\cos\phi = 0.4$ ; L/R = 7 ms)
Rated load	10 (1) A at 250 VAC; 10 (1) A at 30 VDC	7.5 A at 250 VAC; 5 A at 30 VDC	5 A at 250 VAC; 5 A at 30 VDC	2 A at 250 VAC; 3 A at 30 VDC
Rated carry current	10 (1) A		5 A	
Max. operating voltage	380 VAC, 125 VDC		380 VAC, 125 VDC	
Max. operating current	10 (1) A		5 A	
Max. switching capacity	2,500 (250) VA, 300 (30) W	1,875 VA, 150 W	1,250 VA, 150 W	500 VA, 90 W
Min. permissible load	100 mA at 5 VDC (1 mA at 5 VDC)		10 mA at 5 VDC	

**Note:** 1. P level:  $\lambda_{60} = 0.1 \times 10^{-6}$ /operation  
2. ( ): Twin crossbar contact type.

## ■ Characteristics

### Standard Relays

Item	1 pole	2 poles
Contact resistance	30 m $\Omega$ max.	50 m $\Omega$ max.
Operate (set) time	15 ms max.	
Release (reset) time	AC: 10 ms max.; DC: 5 ms max. (w/built-in diode: 20 ms max.)	
Max. operating frequency	Mechanical: 18,000 operations/hr Electrical: 1,800 operations/hr (under rated load)	
Insulation resistance	1,000 M $\Omega$ min. (at 500 VDC)	
Dielectric strength	5,000 VAC, 50/60 Hz for 1 min between coil and contacts*; 1,000 VAC, 50/60 Hz for 1 min between contacts of same polarity	5,000 VAC, 50/60 Hz for 1 min between coil and contacts*; 3,000 VAC, 50/60 Hz for 1 min between contacts of different polarity 1,000 VAC, 50/60 Hz for 1 min between contacts of same polarity
Vibration resistance	Destruction: 10 to 55 Hz, 1.5-mm double amplitude Malfunction: 10 to 55 Hz, 1.5-mm double amplitude	
Shock resistance	Destruction: 1,000 m/s <sup>2</sup> (approx. 100G) Malfunction: 200 m/s <sup>2</sup> when energized (approx. 20G); 100 m/s <sup>2</sup> when no energized (approx. 10G)	
Life expectancy	Mechanical: AC coil: 10,000,000 operations min.; DC coil: 20,000,000 operations min. (at 18,000 operations/hr) Electrical: 100,000 operations min. (at 1,800 operations/hr under rated load)	
Ambient temperature	Operating: -40°C to 70°C (with no icing) Storage: -40°C to 70°C (with no icing)	
Ambient humidity	Operating: 35% to 85% Storage: 35% to 85%	
Weight	Approx. 17 g (plug-in terminal: approx. 20 g)	

**Note:** Values in the above table are the initial values.  
\*2,000 VAC, 50/60 Hz for 1 minute when the P2R-05A or P2R-08A socket is mounted.

## ■ Approved Standards

### UL 508 (File No. E41643)

Model	Contact form	Coil ratings	Contact ratings
G2R-1-S	SPDT	5 to 110 VDC 5 to 240 VAC	10 A, 30 VDC (resistive) 10 A, 250 VAC (general use) TV-3 (NO contact only)
G2R-1A-S	SPST-NO		
G2R-2-S	DPDT		5 A, 30 VDC (resistive) 5 A, 250 VAC (general use) TV-3 (NO contact only)

### CSA 22.2 No.0, No.14 (File No. LR31928)

Model	Contact form	Coil ratings	Contact ratings
G2R-1-S	SPDT	5 to 110 VDC 5 to 240 VAC	10 A, 30 VDC (resistive) 10 A, 250 VAC (general use) TV-3 (NO contact only)
G2R-1A-S	SPST-NO		
G2R-2-S	DPDT		5 A, 30 VDC (resistive) 5 A, 250 VAC (general use) TV-3 (NO contact only)

### SEV (SEV 1025-1, IEC 158-1)

Contact form	Coil ratings	Contact ratings
1 poles	5 to 110 VDC 5 to 240 VAC	10 A, 250 VAC1 5 A, 250 VAC3 10 A, 30 VDC1
2 poles	5 to 240 VAC	5 A, 250 VAC1 2 A, 380 VAC1 5 A, 30 VDC1

### TÜV (IEC 255, VDE 0435)

Contact form	Coil ratings	Contact ratings
1 pole	3 to 110 VDC, 6 VAC to 240 VAC (for Standards coil)	10 A, 250 VAC ( $\cos\phi = 1.0$ ) 10 A, 30 VDC (0 ms)
2 poles		5 A, 250 VAC ( $\cos\phi = 1.0$ ) 5 A, 30 VDC (0 ms) 2.5 A, 250 VAC ( $\cos\phi = 0.4$ )

### VDE (IEC 255, VDE 0435)

Contact form	Coil ratings	Contact ratings
1 pole	5, 6, 9, 12, 18, 24, 48, 60, 100, 110 VDC 12, 18, 24, 48, 50, 100/(110), 110, 120, 200/(220), 220, 230, 240 VAC	10 A, 250 VAC ( $\cos\phi = 1.0$ ) 10 A, 30 VDC (0 ms)
2 poles	5, 6, 9, 12, 18, 24, 48, 60, 100, 110 VDC 12, 18, 24, 48, 50, 100/(110), 110, 120, 200/(220), 220, 230, 240 VAC	5 A, 250 VAC ( $\cos\phi = 1.0$ ) 5 A, 30 VDC (0 ms)

# Engineering Data

## Max. Switching Capacity

### Plug-in Relays

#### G2R-1-S

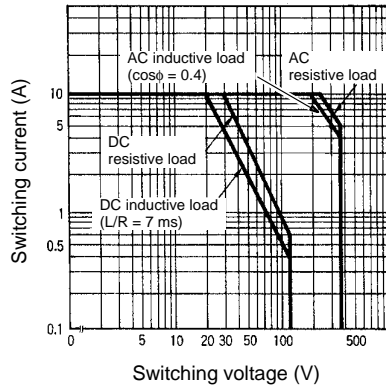

#### G2R-2-S

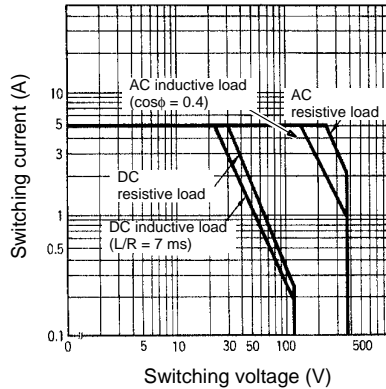

#### G2R-13-S, G2R-1A3-S

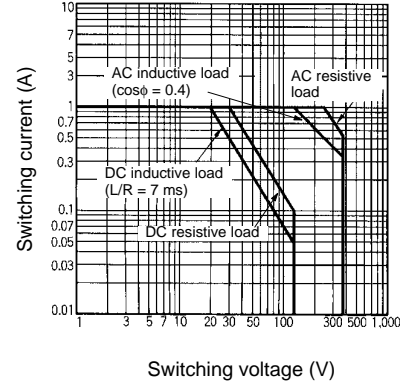

## Life Expectancy

### Plug-in Relays

#### G2R-1-S

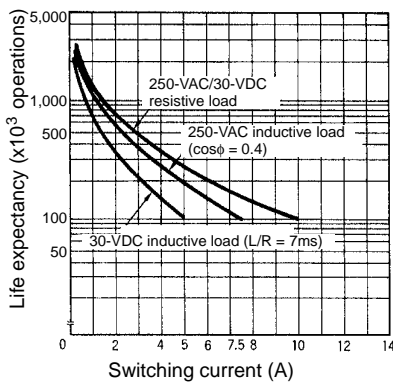

#### G2R-2-S

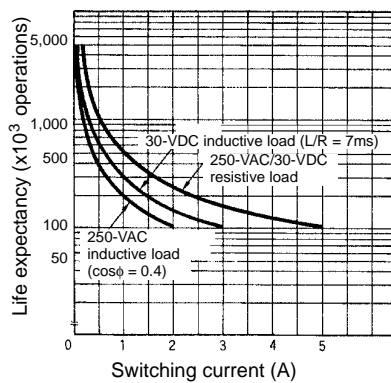

#### G2R-13-S, G2R-1A3-S

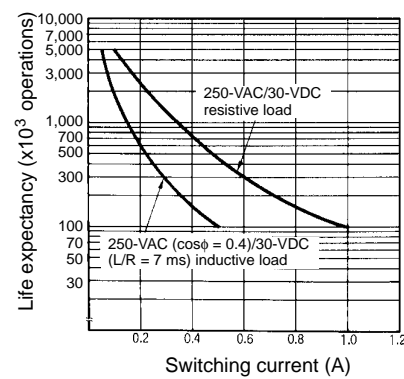

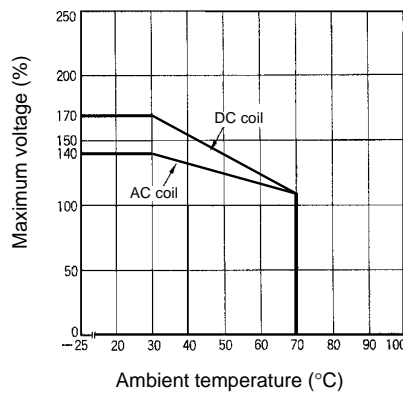

## Ambient Temperature vs Maximum Voltage



**Note:** The maximum voltage refers to the maximum value in a varying range of operating power voltage, not a continuous voltage.

# Dimensions

- Note:** 1. All units are in millimeters unless otherwise indicated.  
 2. Orientation marks are indicated as follows:  

## Relays with Plug-in Terminals

### SPDT Relays

**G2R-1-S, G2R-1-SD, G2R-1-SN, G2R-1-SND, G2R-1-SNI, G2R-1-SNDI**  
**G2R-13-S, G2R-13-SD, G2R-13-SN, G2R-13-SND**

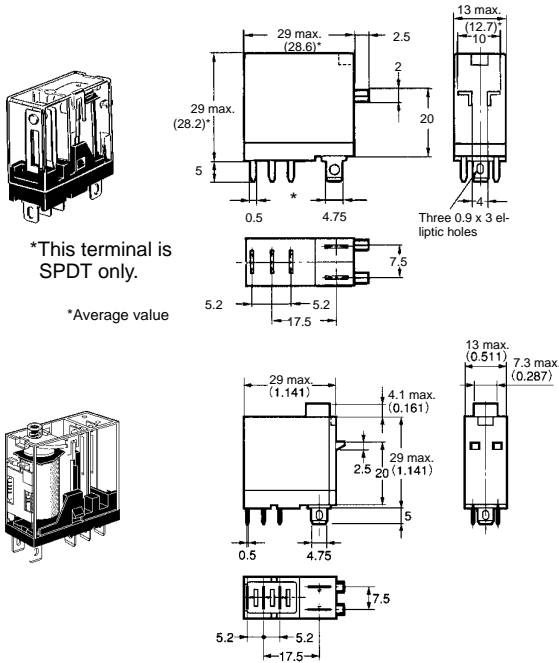

### Terminal Arrangement/Internal Connections (Bottom View)

G2R-1-S, G2R-13-S

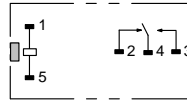

G2R-1-SN, G2R-1-SNI, G2R-13-SN (AC)

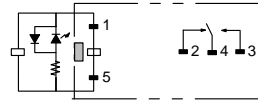

G2R-1-SN, G2R-1-SNI, G2R-13-SN (DC)

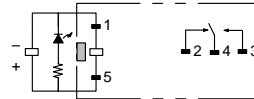

G2R-1-SD, G2R-13-SD (DC)

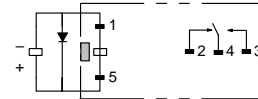

G2R-1-SND, G2R-1-SNDI, G2R-13-SND (DC)

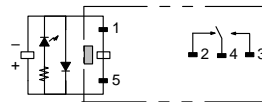

(After confirming coil polarity, wire correctly.)  
 (Except G2R-1-S, G2R-13-S)

### DPDT Relays

**G2R-2-S, G2R-2-SD, G2R-2-SN, G2R-2-SNI, G2R-2-SNDI**  
**G2R-2-SND**

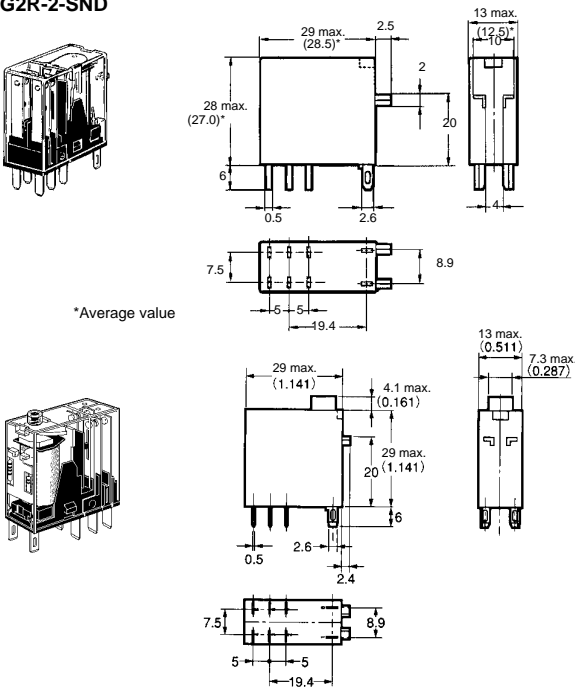

### Terminal Arrangement/Internal Connections (Bottom View)

G2R-2-S

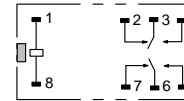

G2R-2-SN G2R-2-SNI (AC)

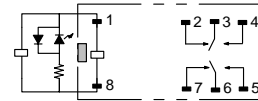

G2R-2-SN G2R-2-SNI (DC)

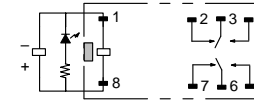

G2R-2-SD (DC)

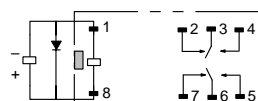

G2R-2-SND G2R-2-SNDI (DC)

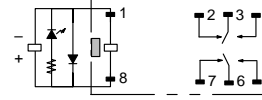

(After confirming coil polarity, wire correctly.)

**Track/Surface Mounting Sockets**

**P2RF-05-E**

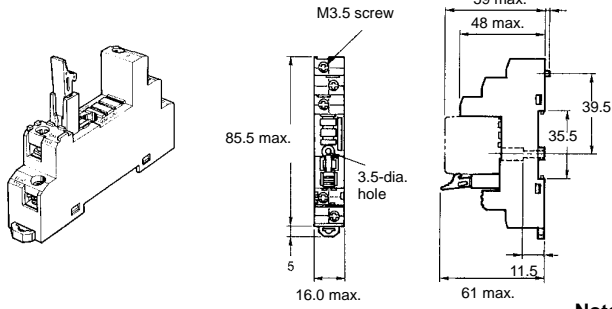

**Terminal Arrangement (Top View)**

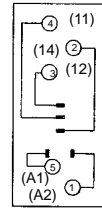

**Mounting Holes (for Surface Mounting)**

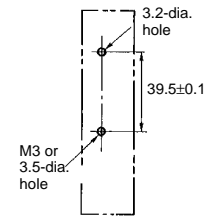

**Note:** Pin numbers in parentheses apply to DIN standard.

**P2RF-08-E**

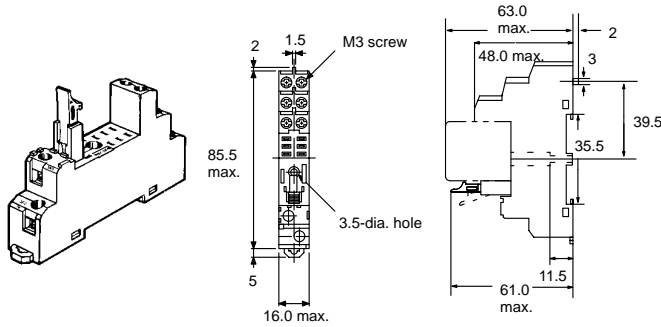

**Terminal Arrangement (Top View)**

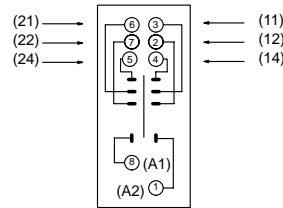

**Mounting Holes (for Surface Mounting)**

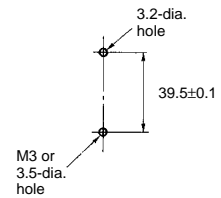

**P2RF-05**

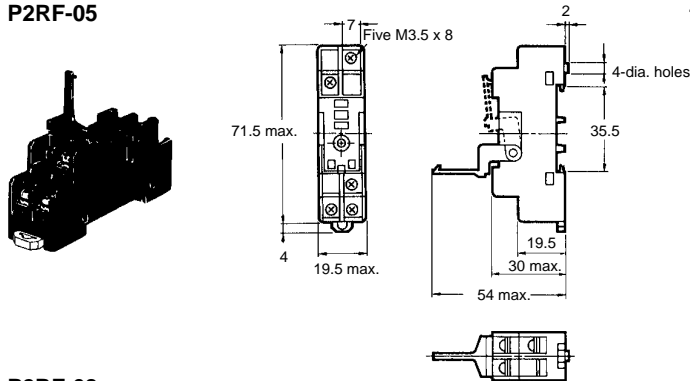

**Terminal Arrangement**

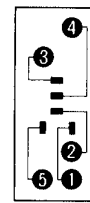

**Mounting Holes (for Surface Mounting)**

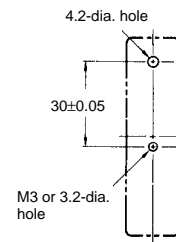

**P2RF-08**

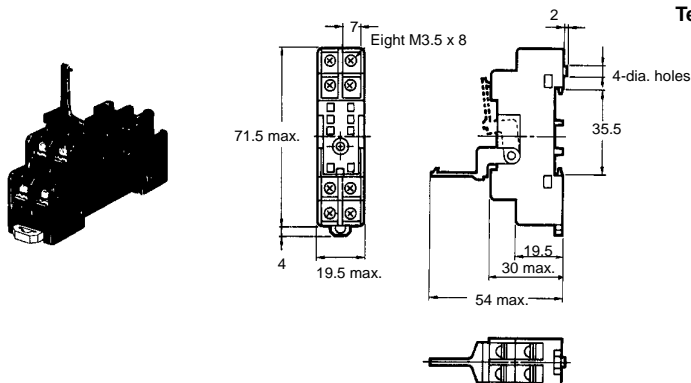

**Terminal Arrangement**

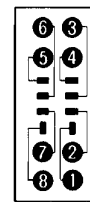

**Mounting Holes (for Surface Mounting)**

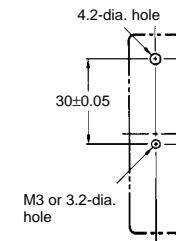

**Back Connecting Sockets**

**P2R-05P (1-pole)**

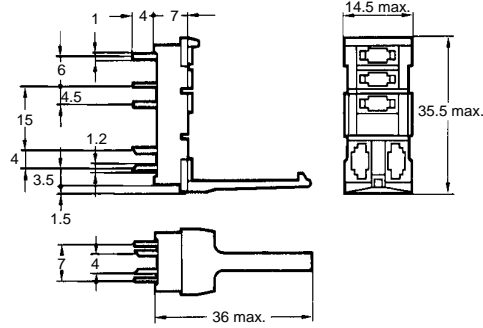
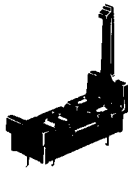

**Terminal Arrangement**

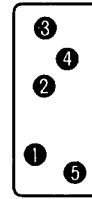

**Mounting Holes**

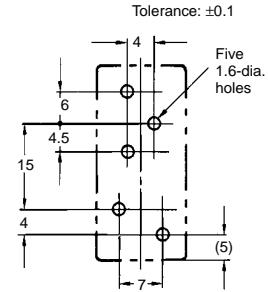

**P2R-08P (2-pole)**

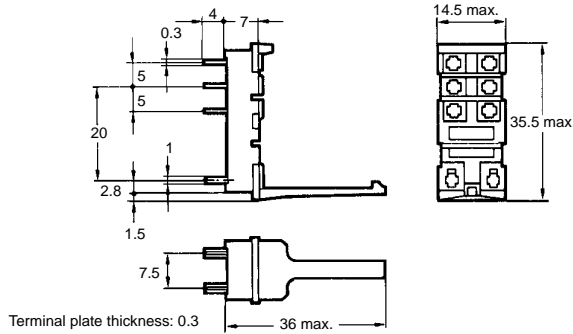
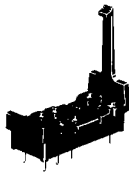

**Terminal Arrangement**

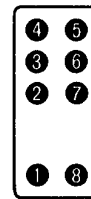

**Mounting Holes**

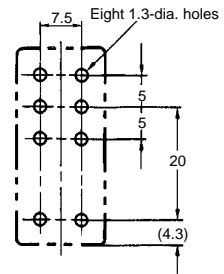

**P2R-05A (1-pole)**

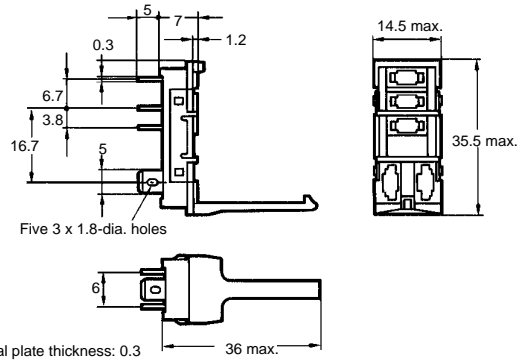
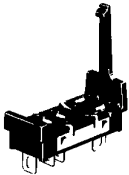

**Terminal Arrangement**

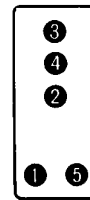

**Panel Cutout**

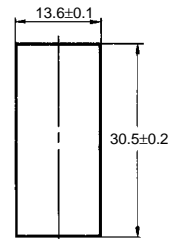

**P2R-08A (2-pole)**

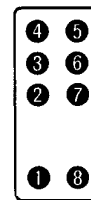
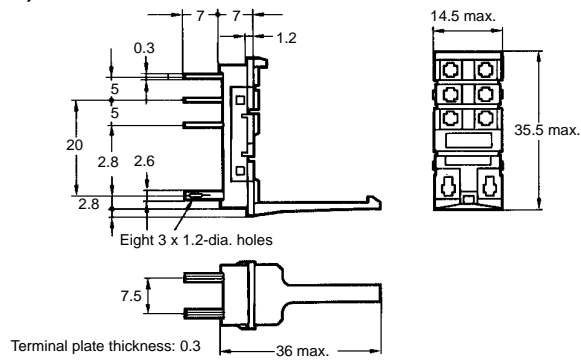
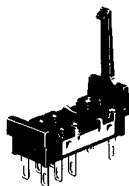

Recommended thickness of the panel is 1.6 to 2.0 mm



**Mounting Height of Relay with Socket**

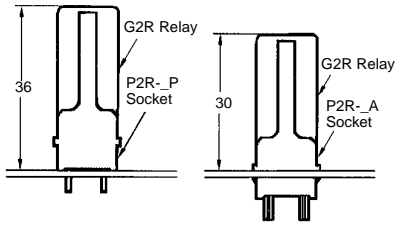

**Mounting Tracks**

PFP-100N, PFP-50N

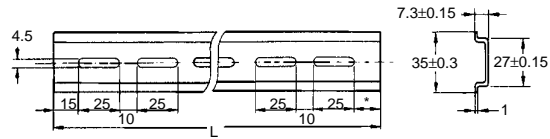
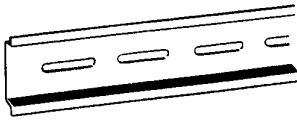

PFP-100N2

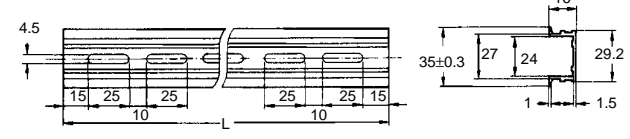
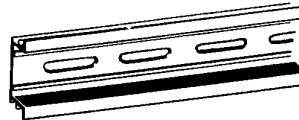

It is recommended to use a panel 1.6 to 2.0 mm thick.

**L: Length**

1 m	PFP-100N
50 cm	PFP-50N
1 m	PFP-100N2

**End Plates**

PFP-M

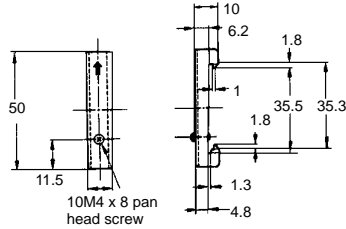
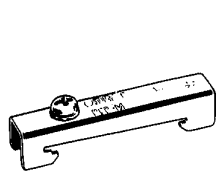

**Spacers**

PFP-S

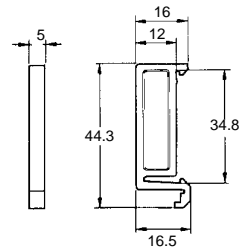
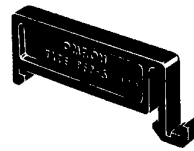

**Mounting Plates**

P2R-P

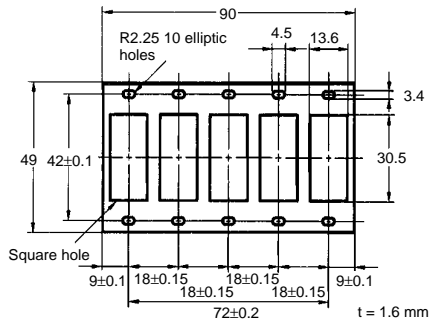



**ALL DIMENSIONS SHOWN ARE IN MILLIMETERS.**

To convert millimeters into inches, multiply by 0.03937. To convert grams into ounces, multiply by 0.03527.

Cat. No. J114-E1-1A **In the interest of product improvement, specifications are subject to change without notice.**

---

**OMRON Corporation**

C&C Components Division H.Q.

Relay Division

28th Fl., Crystal Tower Bldg.,

1-2-27, Shiromi, Chuo-ku,

Osaka 540-6028 Japan

Phone: (81)6-949-6125 Fax: (81)6-949-6134

Printed in Japan

1098-4M (0898) Ⓐ