

**PLEASE CHECK WWW.MOLEX.COM FOR LATEST PART INFORMATION**

**Part Number:** [0522071260](#)  
**Status:** **Active**  
**Overview:**  
**Description:** 1.00mm (.039") Pitch FFC/FPC Connector, SMT, Right Angle, ZIF, Top Contact Style Receptacle, 12 Circuits, Lead-free, Gold Contact Plating, High Barrier Packaging

**Agency Certification**

CSA LR19980  
 UL E29179

**General**

Product Family FFC/FPC Connectors  
 Series [52207](#)  
 Overview [ffc\\_fpc\\_smt](#)  
 Product Name N/A

**Physical**

Circuits (Loaded) 12  
 Color - Resin Natural  
 Contact Position Top  
 Durability (mating cycles max) 30  
 Entry Angle 90° Angle  
 Flammability 94V-0  
 Mated Height (in) 0.106 In  
 Mated Height (mm) 2.70 mm  
 Material - Metal Phosphor Bronze  
 Material - Plating Mating Gold  
 Material - Plating Termination Tin  
 Material - Resin Nylon  
 Number of Rows 1  
 Orientation Right Angle  
 PC Tail Length (in) 0.079 In  
 PC Tail Length (mm) 2.00 mm  
 PCB Locator No  
 PCB Retention Yes  
 Packaging Type Embossed Tape on Reel  
 Pitch - Mating Interface (in) 0.039 In  
 Pitch - Mating Interface (mm) 1.00 mm  
 Polarized to PCB Yes  
 Stackable No  
 Temperature Range - Operating -30°C to +85°C  
 Termination Interface: Style Surface Mount  
 Wire/Cable Type FFC/FPC

**Electrical**

Current - Maximum per Contact 1A  
 Voltage - Maximum 125V

**Material Info**

**Reference - Drawing Numbers**

Packaging Specification SPK-52207-002  
 Product Specification PS-52207-048, RPS-52207-073, RPS-52207-075, RPS-52207-078, RPS-52207-084, RPS-52207-090, RPS-52207-092, RPS-52207-094, RPS-52207-099, RPS-52207-101, RPS-52207-104, RPS-52207-106  
 Sales Drawing SD-52207-064, SD-52207-065

**EU RoHS** **China RoHS**

**ELV and RoHS Compliant**  
**REACH SVHC**  
**Contains SVHC: No**  
**Halogen-Free Status**



**Not Halogen-Free**  
**Need more information on product environmental compliance?**

Email [productcompliance@molex.com](mailto:productcompliance@molex.com)  
 For a multiple part number RoHS Certificate of Compliance, [click here](#)

Please visit the [Contact Us](#) section for any non-product compliance questions.

**Search Parts in this Series**  
[52207Series](#)

This document was generated on 06/04/2010

**PLEASE CHECK WWW.MOLEX.COM FOR LATEST PART INFORMATION**

10 9 8 7 6 5 4 3 2 1

注記 NOTES

△ 接点部までの嵌合長さ。  
MATING LENGTH TO CONTACT POINT.

2. 使用材料 MATERIAL  
ハウジング : 46ナイロン (耐熱性), UL94V-0  
ハウジング : HEAT-RESISTANT NYLON46, UL94V-0  
アクチュエータ : PPS, UL94V-0  
アクチュエータ : PPS, UL94V-0  
ターミナル : リン青銅 (t=0.32)

メッキ  
コンタクト部 : 金メッキ 0.1マイクロメートル以上  
テール部 : 銅メッキ 1.0マイクロメートル以上  
下地メッキ : ニッケル 1.0マイクロメートル以上

TERMINAL : PHOS-BRO(I+0.32)  
PLATED  
CONTACT AREA : GOLD PLATED 0.1MICROMETER MIN.  
TAIL AREA : TIN PLATED 1.0MICROMETER MIN.  
OVER PLATED : NICKEL PLATED 1.0MICROMETER MIN.

金具 : 銅合金 (t=0.25)

メッキ : 銅メッキ 1マイクロメートル以上  
下地メッキ : ニッケル 1マイクロメートル以上  
FITTING NAIL : PHOS-BRO(I+0.25)  
PLATED  
TIN PLATED 1MICROMETER MIN.  
OVER PLATED : NICKEL PLATED 1MICROMETER MIN.

△ パターンはくり止め用金具  
FITTING NAIL FOR PREVENTION OF FOOT PRINT PEELING.

4. エンボステープ梱包時は、アクチュエータが  
ロックした状態とする。  
ACTUATOR TO BE LOCKED IN EMBOSSED TAPE PACKAGE.

△ FPC挿入深さ  
INSERTION DEPTH OF FPC.

△ パターン書き込み禁止エリア。  
NO FOOT PRINT AREA.

△ テール及び金具の平坦度は、0.15以下とする。  
COPLANARITY OUT OF SPECIFICATION.  
TAL : 0.15 MAX.  
NAL : 0.15 MAX.

8. 本製品は 52207-xx19 の鉛フリー品である。  
THIS PRODUCT IS GOLD PLATING OF 52207-xx19.

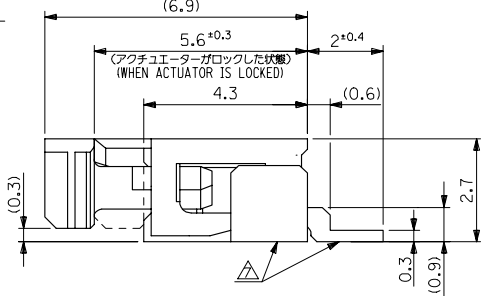
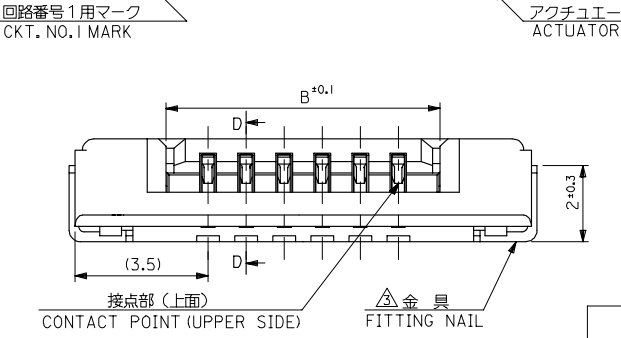
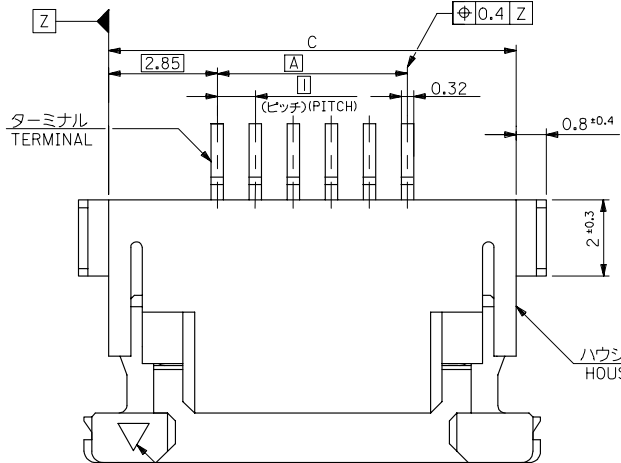

34.7	31.2	29	52207-3067	30
33.7	30.2	28	52207-2967	29
32.7	29.2	27	52207-2867	28
31.7	28.2	26	52207-2767	27
30.7	27.2	25	52207-2667	26
29.7	26.2	24	52207-2567	25
28.7	25.2	23	52207-2467	24
27.7	24.2	22	52207-2367	23
26.7	23.2	21	52207-2267	22
25.7	22.2	20	52207-2167	21
24.7	21.2	19	52207-2067	20
23.7	20.2	18	52207-1967	19
22.7	19.2	17	52207-1867	18
21.7	18.2	16	52207-1767	17
20.7	17.2	15	52207-1667	16
19.7	16.2	14	52207-1567	15
18.7	15.2	13	52207-1467	14
17.7	14.2	12	52207-1367	13
16.7	13.2	11	52207-1267	12
15.7	12.2	10	52207-1167	11
14.7	11.2	9	52207-1067	10
13.7	10.2	8	52207-0967	9
12.7	9.2	7	52207-0867	8
11.7	8.2	6	52207-0767	7
10.7	7.2	5	52207-0667	6
9.7	6.2	4	52207-0567	5
8.7	5.2	3	52207-0467	4
7.7	4.2	2	52207-0367	3
C	B	A	MATERIAL NO.	桁数
			MODEL NO. 52207-xx67	CIRCUITS

REVISED IEC NO. J2007-0873 2006/09/22 DRWN: OTANI CHKCY: MEDA 2007/03/23 APPR: NUKITA 2007/03/26	GENERAL TOLERANCES (UNLESS SPECIFIED)		DIMENSION STYLE MM ONLY		SCALE 10:1	DESIGN UNITS METRIC	THIRD ANGLE PROJECTION	
	10 UNDER	±0.2	DRAWN BY M.UMEDA	DATE 2005/03/02	TITLE 1.0 FPC CONN. ZIF SMT HSG ASSY -LEAD FREE-			
	10 OVER 30 UNDER	±0.25	CHECKED BY K.TOYODA	DATE 2005/03/02	MOLEX INCORPORATED			
	30 OVER	±0.3	APPROVED BY N.UKITA	DATE 2005/03/02	DOCUMENT NO. SD-52207-064			
ANGULAR ±1 °		DRAFT WHERE APPLICABLE MUST REMAIN WITHIN DIMENSIONS		MATERIAL NO. SEE CHART	SHEET NO. 1 OF 2			
SIZE A3				THIS DRAWING CONTAINS INFORMATION THAT IS PROPRIETARY TO MOLEX INCORPORATED AND SHOULD NOT BE USED WITHOUT WRITTEN PERMISSION				

10 9 8 7 6 5 4 3 2 1

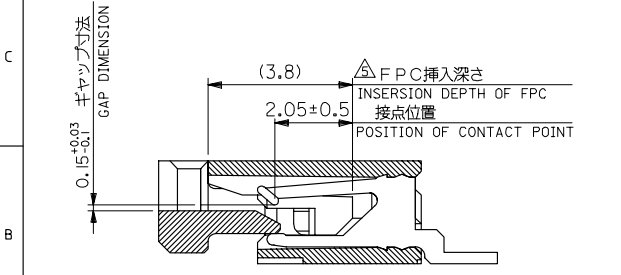
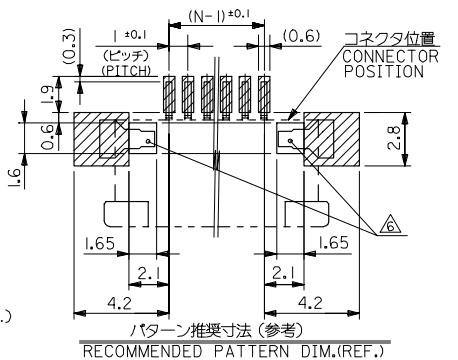
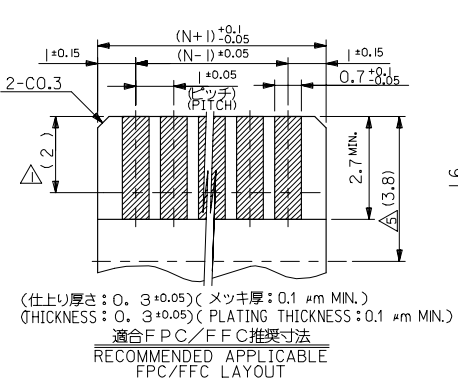
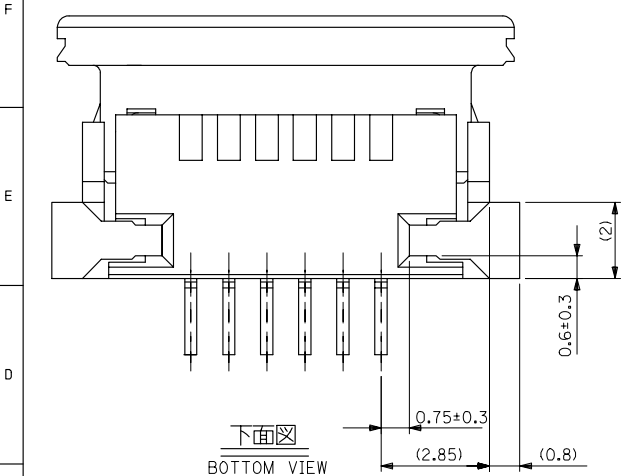

FPCについて:  
打抜き方向は、導体側から補強板側を推奨いたします。  
補強フィルム材質は、ポリイミドを推奨いたします。  
接着剤は、熱硬化接着剤を推奨いたします。

ABOUT FPC:  
RECOMMENDED PUNCHER DIRECTION: FROM CONDUCTOR SIDE TO STIFFENER BOARD SIDE.  
RECOMMENDED MATERIAL:  
STIFFENER FILM: POLYIMIDE  
BONDING AGENT: THERMOSETTING BONDING AGENT

REVISED EC NO: J2007-0873 DRWN: YOTANI CHKD: Y. MEDA APPR: NUKITA	2006/09/22	GENERAL TOLERANCES (UNLESS SPECIFIED)		DIMENSION STYLE MM ONLY		SCALE 10:1	DESIGN UNITS METRIC	THIRD ANGLE PROJECTION
	2007/03/23	10 UNDER	±0.2	DRAWN BY M.UMEDA	DATE 2005/03/02	TITLE 1.0 FPC CONN. ZIF SMT HSG ASSY -LEAD FREE-		
	2007/03/26	10 OVER 30 UNDER	±0.25	CHECKED BY K.TOYODA	DATE 2005/03/02			
			30 OVER	±0.3	APPROVED BY N.UKITA	DATE 2005/03/02	MOLEX INCORPORATED	
		ANGULAR	±1 °	MATERIAL NO. SEE SHEET 1		DOCUMENT NO. SD-52207-064	SHEET NO. 2 OF 2	
DRAFT WHERE APPLICABLE MUST REMAIN WITHIN DIMENSIONS			THIS DRAWING CONTAINS INFORMATION THAT IS PROPRIETARY TO MOLEX INCORPORATED AND SHOULD NOT BE USED WITHOUT WRITTEN PERMISSION					

fb\_frame\_A3\_1\_ME\_S  
Rev. D 2004/04/02

9 8 7 6 5 4 3 2 1 EN-02JA(021)

10 9 8 7 6 5 4 3 2 1

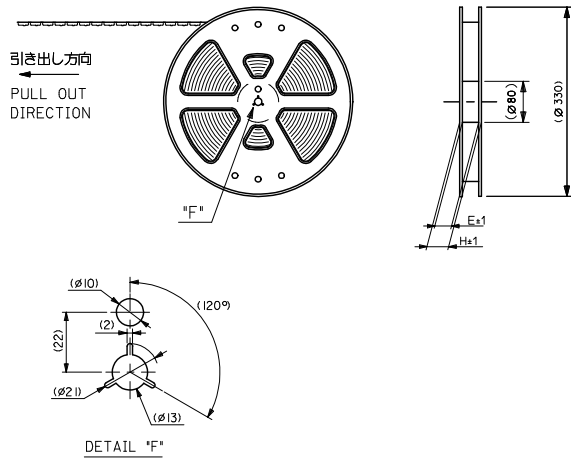

注記

- 製品番号 52207-\*\*67 の梱包状態はアクチュエータがロックした状態とする。  
詳細寸法については図面 SD-52207-064 を参照下さい。  
IN THE PACKAGE, ACTUATOR OF PART NO.52207-\*\*67 SHOULD BE LOCKED RE DETAILED DIMENSIONS, SEE SD-52207-064.
- 梱包数量：1000個/リール  
NUMBER OF CONNECTORS：1000PCS/REEL
- リードテープ長さ(LEAD TAPE LENGTH)

トップテープ TOP TAPE      トップテープ TOP TAPE  
リーダー部 LEADER PART      未接着部 NON-BONDED PART

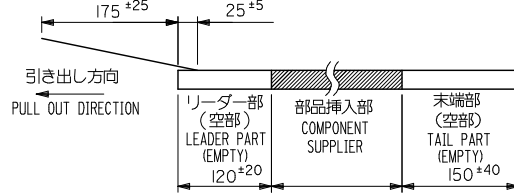

- トップテープの剥離強度：0.1~1.3N (10gf~130gf) (剥離方向は下図参照) 尚、本規格値は、出荷時に適用。(但し、輸送時に剥離が発生しない事。)  
PEELING OFF FORCE OF TOP TAPE：0.1~1.3N (10gf~130gf)  
(PEELING DIRECTION AS SHOWN IN FOLLOWING FIG.)  
THIS REQUIREMENT SHOULD BE APPLIED AT SHIPMENT.(PEEL OFF SHOULD NOT BE ALLOWED, DURING TRANSPORTATION.)

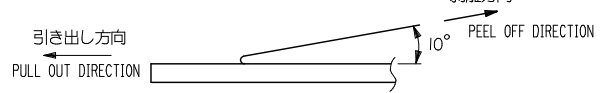

- 材料 (MATERIAL)  
キャリアテープ (CARRIER TAPE)：ポリプロピレン (POLYPROPYLENE)  
トップテープ (TOPTAPE)：PET, PE, PEF  
リール (REEL)：ポリスチレン (PS) <リサイクル材を含む>  
POLYSTYRENE (PS) <RECYCLE MATERIAL CONTAINED>
- 本製品は 52207-\*\*85 の金メッキ品である。  
THIS PRODUCT IS GOLD PLATING OF 52207-\*\*85.
- 本製品は乾燥剤入り、ハイバリア梱包仕様である。  
THIS PRODUCT IS HIGH BARRIER PACKAGE WITH DESICCANT.

MODEL No.52207-\*\*60

REVISED EC NO: J2009-2061 DRAWN BY MURAKAMI 2009/05/20 CHECKED BY CHYUHMATSUMOTO 2009/05/21 APPROVED BY APPRENIKITA 2009/05/21	DESCRIPTION	GENERAL TOLERANCES (UNLESS SPECIFIED)		DIMENSION STYLE MM ONLY		SCALE ---	DESIGN UNITS METRIC	THIRD ANGLE PROJECTION	
		10 UNDER	±0.2	DRAWN BY M.UMEDA	DATE 2005/03/03	TITLE 1.0 FPC CONN. ZIF SMT WITH EMBSTP PKG -LEAD FREE-			
		10 OVER 30 UNDER	±0.25	CHECKED BY K.TOYODA	DATE 2005/03/03	MOLEX INCORPORATED			
		30 OVER	±0.3	APPROVED BY N.UKITA	DATE 2005/03/03	DOCUMENT NO. SD-52207-065			
G	REV	ANGULAR ±1 ° DRAFT WHERE APPLICABLE MUST REMAIN WITHIN DIMENSIONS		MATERIAL NO. SEE SHEET 2		SHEET NO. 1 OF 5		THIS DRAWING CONTAINS INFORMATION THAT IS PROPRIETARY TO MOLEX INCORPORATED AND SHOULD NOT BE USED WITHOUT WRITTEN PERMISSION	

10 9 8 7 6 5 4 3 2 1

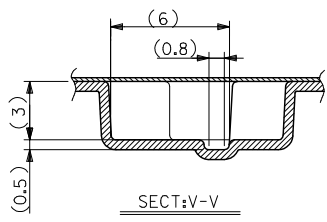
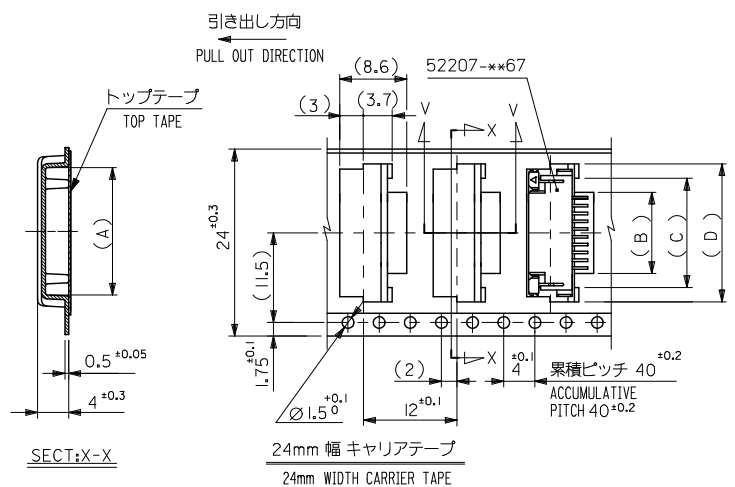
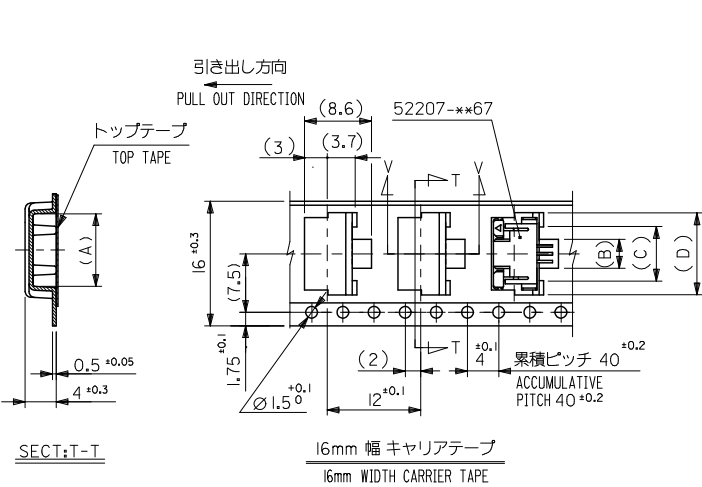

24	29.4	25.4	18.5	15	11.7	17.3	52207-1160	11
			17.5	14	10.7	16.3	52207-1060	10
			16.5	13	9.7	15.3	52207-0960	9
			15.5	12	8.7	14.3	52207-0860	8
			14.5	11	7.7	13.3	52207-0760	7
			13.5	10	6.7	12.3	52207-0660	6
			12.5	9	5.7	11.3	52207-0560	5
11.5	8	4.7	10.3	52207-0460	4			
16	21.4	17.4	10.5	7	3.7	9.3	52207-0360	3
キャリアテープ幅 CARRIER TAPE WIDTH	H	E	(D)	(C)	(B)	(A)	MATERIAL NO. MODEL NO. 52207-xx60	種数 CKT.

REVISED IEC NO: J2009-2061 DRAWN BY: DRWNTKON 2009/05/20 CHECKED BY: CHYKHMATSUMOTO 2009/05/21 APPROVED BY: APPRNUKITA 2009/05/21 G	GENERAL TOLERANCES (UNLESS SPECIFIED)		DIMENSION STYLE MM ONLY		SCALE ---	DESIGN UNITS METRIC	THIRD ANGLE PROJECTION	
	10 UNDER	±0.2	DRAWN BY M.UMEDA	DATE 2005/03/03	TITLE 1.0 FPC CONN. ZIF SMT WITH EMBSTP PKG -LEAD FREE-			
	10 OVER 30 UNDER	±0.25	CHECKED BY K.TOYODA	DATE 2005/03/03	MOLEX INCORPORATED			
	30 OVER	±0.3	APPROVED BY N.UKITA	DATE 2005/03/03	MATERIAL NO. SEE TABLE		DOCUMENT NO. SD-52207-065	SHEET NO. 2 OF 5
	ANGULAR ±1 °		THIS DRAWING CONTAINS INFORMATION THAT IS PROPRIETARY TO MOLEX INCORPORATED AND SHOULD NOT BE USED WITHOUT WRITTEN PERMISSION					
DRAFT WHERE APPLICABLE MUST REMAIN WITHIN DIMENSIONS								

10 9 8 7 6 5 4 3 2 1

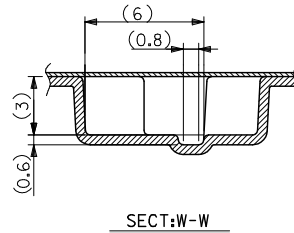
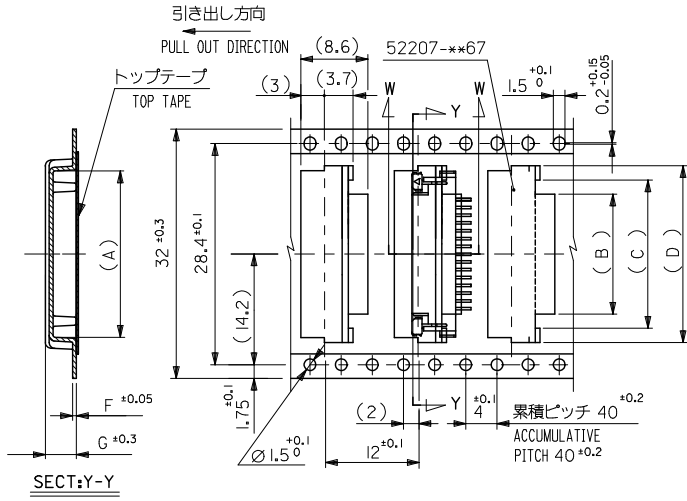

32mm 幅 キャリアテープ  
32mm WIDTH CARRIER TAPE

32	37.4	33.4	4.0	0.5	23.5	20	16.7	22.35	52207-1660	16
			4.2	0.6	22.5	19	15.7	21.35	52207-1560	15
			4.2	0.6	21.5	18	14.7	20.35	52207-1460	14
			4.2	0.6	20.5	17	13.7	19.35	52207-1360	13
			4.2	0.6	19.5	16	12.7	18.35	52207-1260	12
キャリアテープ幅 CARRIER TAPE WIDTH	H	E	(G)	(F)	(D)	(C)	(B)	(A)	MATERIAL NO. MODEL NO. 52207-**-60	種数 CKT.

REVISED EC NO: J2009-2061 DRAWN BY: IRWNTKON CHKD BY: CHYKHMATSUOTO APPR: NIKITA G	DESCRIPTION 2009/05/20 2009/05/21 2009/05/21	GENERAL TOLERANCES (UNLESS SPECIFIED)		DIMENSION STYLE MM ONLY		SCALE ---	DESIGN UNITS METRIC	THIRD ANGLE PROJECTION	
		10 UNDER	±0.2	DRAWN BY M.UMEDA	DATE 2005/03/03	TITLE 1.0 FPC CONN ZIF SMT WITH EMBSTP PKG -LEAD FREE-			
		10 OVER 30 UNDER	±0.25	CHECKED BY K.TOYODA	DATE 2005/03/03	MOLEX INCORPORATED			
		30 OVER	±0.3	APPROVED BY N.UKITA	DATE 2005/03/03	MATERIAL NO. SEE TABLE	DOCUMENT NO. SD-52207-065	SHEET NO. 3 OF 5	
		ANGULAR ±1 °		DRAFT WHERE APPLICABLE MUST REMAIN WITHIN DIMENSIONS		SIZE A3 THIS DRAWING CONTAINS INFORMATION THAT IS PROPRIETARY TO MOLEX INCORPORATED AND SHOULD NOT BE USED WITHOUT WRITTEN PERMISSION			

10 9 8 7 6 5 4 3 2 1

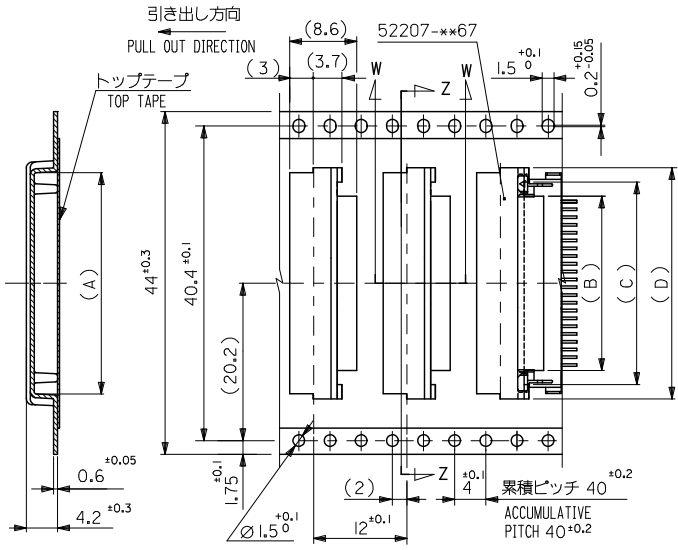

SECT:Z-Z

44mm 幅 キャリアテープ  
44mm WIDTH CARRIER TAPE

44	49.4	45.4	—	—	34.5	30	27.7	33.35	52207-2760	27
			—	—	33.5	30	26.7	32.35	52207-2660	26
			—	—	32.5	29	25.7	31.35	52207-2560	25
			—	—	31.5	28	24.7	30.35	52207-2460	24
			—	—	29.5	26	22.7	28.35	52207-2260	22
			—	—	28.5	25	21.7	27.35	52207-2160	21
			—	—	27.5	24	20.7	26.35	52207-2060	20
			—	—	26.5	23	19.7	25.35	52207-1960	19
—	—	25.5	22	18.7	24.35	52207-1860	18			
キャリアテープ幅 CARRIER TAPE WIDTH	H	E	(G)	(F)	(D)	(C)	(B)	(A)	MATERIAL NO. MODEL NO. 52207-**60	種数 CKT.

REVISED IEC NO: J2009-2061 DRAWN BY: IRWNTKON CHECKED BY: CHYKOHMATSUMOTO APPROVED BY: APPR:NIKIITA DATE: 2009/05/20 DATE: 2009/05/21 DATE: 2009/05/21	GENERAL TOLERANCES (UNLESS SPECIFIED)		DIMENSION STYLE MM ONLY		SCALE ---	DESIGN UNITS METRIC	THIRD ANGLE PROJECTION	
	10 UNDER	±0.2	DRAWN BY M.UMEDA	DATE 2005/03/03	TITLE 1.0 FPC CONN ZIF SMT WITH EMBSTP PKG -LEAD FREE-			
	10 OVER 30 UNDER	±0.25	CHECKED BY K.TOYODA	DATE 2005/03/03	MOLEX INCORPORATED			
	30 OVER	±0.3	APPROVED BY N.UKIITA	DATE 2005/03/03	MATERIAL NO. SEE TABLE	DOCUMENT NO. SD-52207-065	SHEET NO. 4 OF 5	
ANGULAR ±1°		DRAFT WHERE APPLICABLE MUST REMAIN WITHIN DIMENSIONS		THIS DRAWING CONTAINS INFORMATION THAT IS PROPRIETARY TO MOLEX INCORPORATED AND SHOULD NOT BE USED WITHOUT WRITTEN PERMISSION				

ib\_frame\_A3\_J\_ME\_S  
Rev. E 2006/04/15

EN-02JA(021)



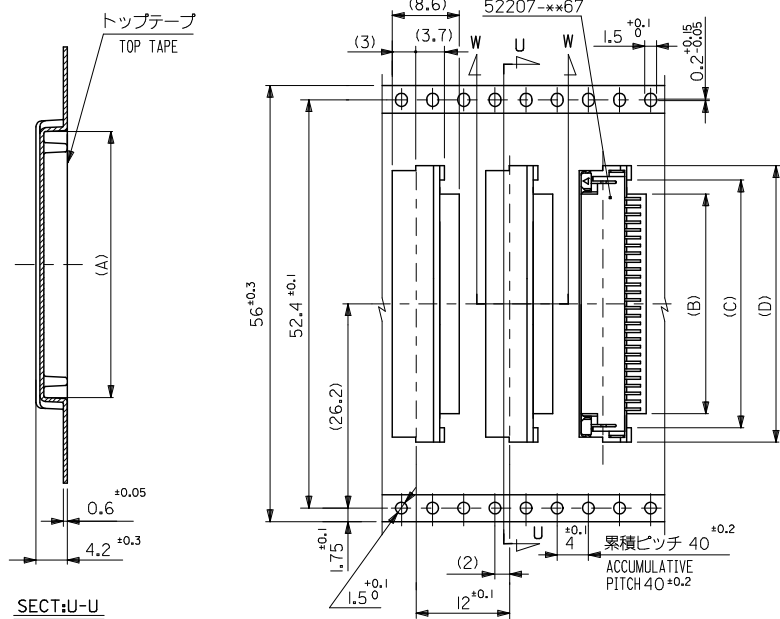

56mm 幅 キャリアテープ  
56mm WIDTH CARRIER TAPE

56	61.4	57.4	37.5	34	30.7	36.35	52207-3060	30
キャリアテープ幅 CARRIER TAPE WIDTH	F	E	(D)	(C)	(B)	(A)	MATERIAL NO.	CIRCUIT
			36.5	33	29.7	35.35	52207-2960	29
			35.5	32	28.7	34.35	52207-2860	28

REVISED EC NO: J2009-2061 DRAWN BY: DRWNTKON CHKD BY: CHYKHMATSUMOTO APPR: NIKITA G	GENERAL TOLERANCES (UNLESS SPECIFIED)		DIMENSION STYLE MM ONLY		SCALE ---	DESIGN UNITS METRIC	MODEL NO. 52207-**60	
	10 UNDER	±0.2	DRAWN BY M.UMEDA	DATE 2005/03/03	TITLE 1.0 FPC CONN ZIF SMT WITH EMBSTP PKG -LEAD FREE-			
	10 OVER 30 UNDER	±0.25	CHECKED BY K.TOYODA	DATE 2005/03/03	THIRD ANGLE PROJECTION			
	30 OVER	±0.3	APPROVED BY N.UKITA	DATE 2005/03/03	MOLEX INCORPORATED			
	ANGULAR ±1°	DRAFT WHERE APPLICABLE MUST REMAIN WITHIN DIMENSIONS		MATERIAL NO. SEE TABLE	DOCUMENT NO. SD-52207-065	SHEET NO. 5 OF 5		