



LCD Driver IC

PT6601

DESCRIPTION

PT6601 is a Segment Driver LCD Driver IC utilizing CMOS Technology used for Large Scale Dot Matrix Liquid Crystal Graphic Displays. 80 bits of display data sent from a controller are latched using a 4-bit parallel transfer technique and LCD drive signals are generated. It can be used with Common LCD Driver, PT6630 to drive Large Screen LCD Panels.

FEATURES

- CMOS Technology
- Supports Display Duties from 1/64 to 1/256
- Operating Supply Voltage:
 - VDD (Logic Block): 5V \pm 10%
 - VDD - VEE (LCD Block): 12 to 32 V
- Operating Temperature: -20 to +75 °C
- Supports Power Reduction in Large Scale Panel via a Chip Disable Pin
- LCD Drive Circuit for 80 bits Display
- 4 -Bit Parallel Data Input
- Maximum of 6.0 MHz Data Transfer Clock and Bidirectional Shifting Supported
- Available in C.O.B. or 100-pin, QFP Package

APPLICATION

- Peripheral Device

ORDER INFORMATION

Valid Part Number	Package Type
PT6601	100 Pins, QFP Package
PT6601-H	C.O.B.



LCD Driver IC

PT6601

PIN CONFIGURATION

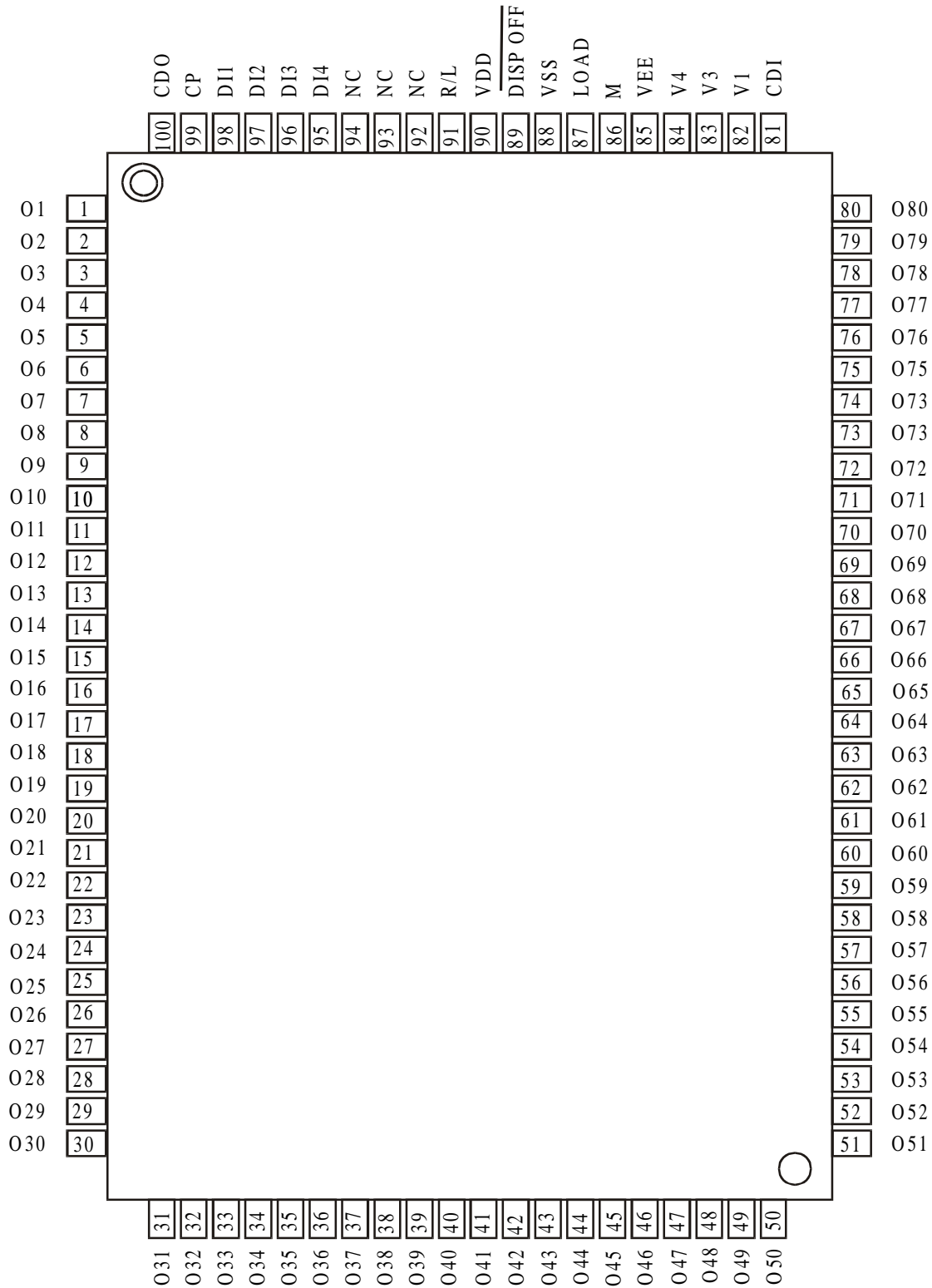



LCD Driver IC

PT6601

APPLICATION CIRCUIT

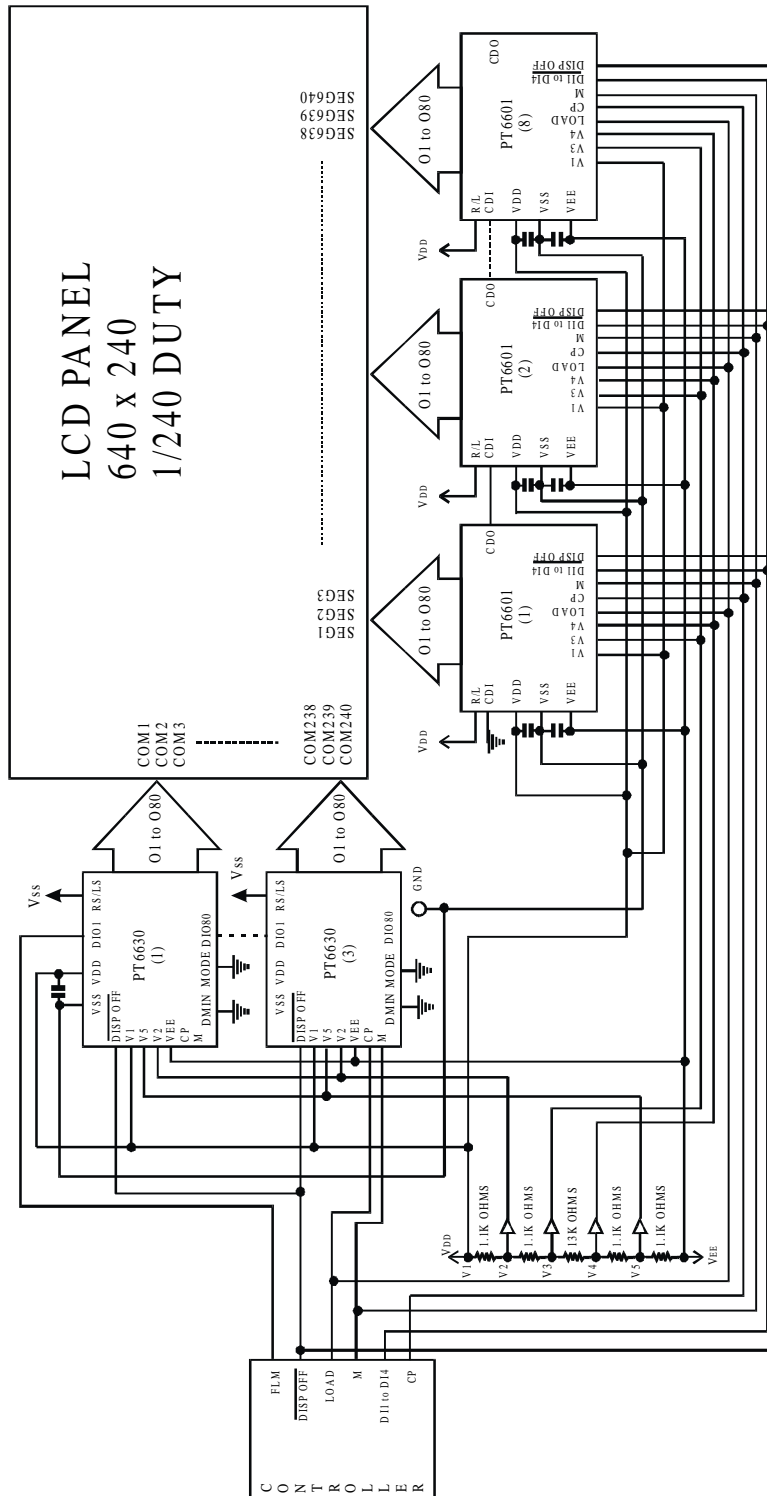

Note: VDD=5V, VEE=-20V, V1=5V, V2=3.4V, V3=1.5V, V4=-16.8V, V5=-18.4V



LCD Driver IC

PT6601

PAD CONFIGURATION

