

704-313

UMC



UM621024C Series

128K X 8 CMOS SRAM

PRELIMINARY

Features

- Single +5V power supply
- Access times: 55/70 ns (max.)
- Current:
 - Low power version: Operating: 70mA (max.) Standby: 100 μ A (max.)
 - Very low power version: Operating: 70mA (max.) Standby: 25 μ A (max.)
- Fully static operation, no clock or refreshing required
- Directly TTL compatible: All inputs and outputs
- Common I/O using three-state output
- Output enable and two chip enable inputs for easy application
- Data retention voltage: 2V (min.)
- Available in 32-pin DIP, SOP or TSOP packages

General Description

The UM621024C is a low operating current 1,048,576-bit static random access memory organized as 131,072 words by 8 bits and operates on single 5V power supply. It is built using UMC's high performance CMOS process. Inputs and three-state outputs are TTL compatible and allow for direct interfacing with common system bus structures.

Two chip enable inputs are provided for power down and device enable and an output enable input is included for easy interface. Data retention is guaranteed at a power supply voltage as low as 2V.

Pin Configurations

■ DIP

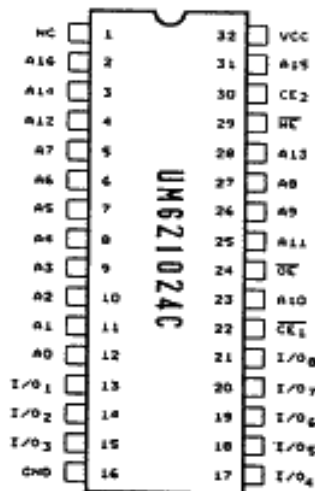

■ SOP

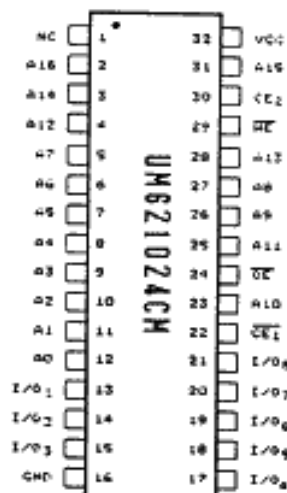

■ TSOP (forward type)

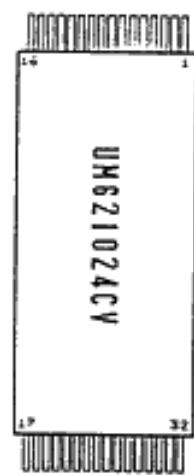

(reverse type)

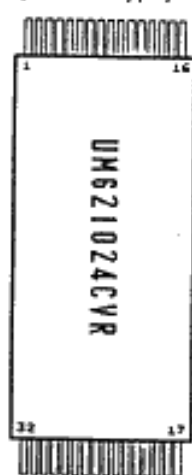

Pin No.	1	2	3	4	5	6	7	8	9	10	11
Pin Name	A11	A9	A8	A13	WE	CE2	A15	VCC	NC	A16	A14
Pin No.	12	13	14	15	16	17	18	19	20	21	22
Pin Name	A12	A7	A6	A5	A4	A3	A2	A1	A0	I/O1	I/O2
Pin No.	23	24	25	26	27	28	29	30	31	32	
Pin Name	I/O3	GND	I/O4	I/O5	I/O6	I/O7	I/O8	CE1	A10	OE	

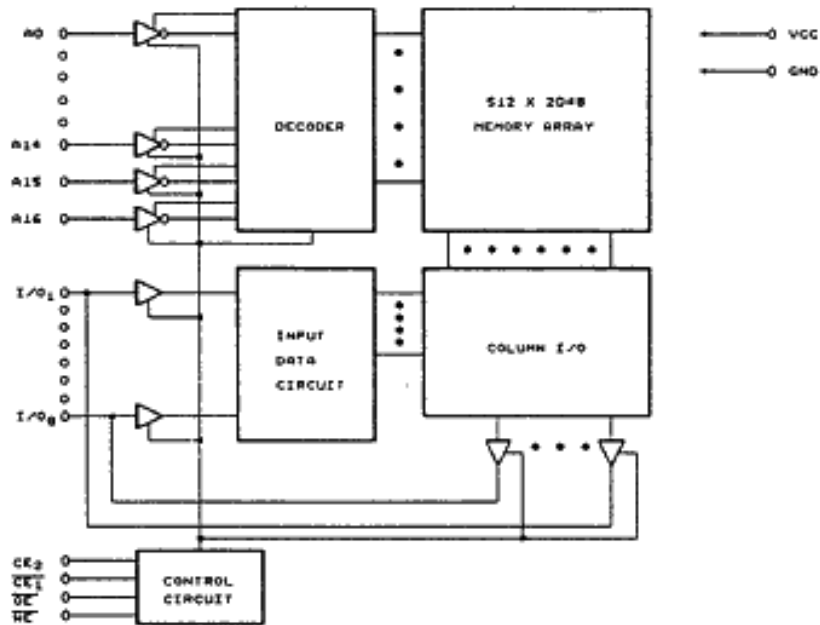
Block Diagram

Pin Descriptions — DIP/SOP

Pin No.	Symbol	Description
2 - 12, 23, 25 - 28, 31	A0 - A16	Address Input
29	\overline{WE}	Write Enable
24	\overline{OE}	Output Enable
22	$\overline{CE1}$	Chip Enable
30	CE2	Chip Enable
1	NC	No Connection
13-15, 17-21	I/O ₁ - I/O ₈	Data Input/Output
32	VCC	Power Supply (+5V)
16	GND	Ground

Pin Description — TSOP

Pin No.	Symbol	Description
1 - 4, 7, 10 - 20, 31	A0 - A16	Address Input
5	\overline{WE}	Write Enable
32	\overline{OE}	Output Enable
30	$\overline{CE1}$	Chip Enable
6	CE2	Chip Enable
9	NC	No Connection
21-23, 25-29	I/O ₁ - I/O ₈	Data Input/Output
8	VCC	Power Supply
24	GND	Ground

Recommended DC Operating Conditions

(TA = 0°C to + 70°C)

Symbol	Parameter	Min.	Typ.	Max.	Unit
VCC	Supply Voltage	4.5	5.0	5.5	V
GND	Ground	0	0	0	V
V _{IH}	Input High Voltage	2.2	3.5	VCC + 0.3	V
V _{IL}	Input Low Voltage	-0.3	0	+0.8	V
C _L	Output Load	-	-	30	pF
TTL	Output Load	-	-	1	-

Absolute Maximum Ratings*

VCC to GND	-0.5V to +7.0V
IN, IN/OUT Volt to GND	-0.5V to VCC + 0.5V
Operating Temperature, T _{opr}	0°C to +70°C
Storage Temperature, T _{stg}	-55°C to +125°C
Temperature Under Bias, T _{bias}	-10°C to +85°C
Power Dissipation, P _T	0.7W
Soldering Temp. & Time	260°C, 10 sec

***Comments**

Stresses above those listed under "Absolute Maximum Ratings*" may cause permanent damage to the device. These are stress ratings only. Functional operation of this device at these or any other conditions above those indicated in the operational sections of this specification is not implied and exposure to absolute maximum rating conditions for extended periods may affect device reliability.

DC Electrical Characteristics (TA = 0°C to + 70°C, VCC = 5V ± 10%, GND = 0V)

Symbol	Parameter	UM621024C-55L/70L		UM621024C-55LL/70LL		Unit	Conditions
		Min.	Max.	Min.	Max.		
I _I	Input Leakage Current	-	1	-	1	μA	V _{IH} = GND to VCC
I _O	Output Leakage Current	-	1	-	1	μA	$\overline{CE1} = V_{IH}$ or $CE2 = V_{IL}$ or $\overline{OE} = V_{IH}$ or $\overline{WE} = V_{IL}$ V _{I/O} = GND to VCC
I _{CC}	Active Power Supply Current	-	15	-	15	mA	$\overline{CE1} = V_{IL}$, $CE2 = V_{IH}$ I _{I/O} = 0 mA

DC Electrical Characteristics (continued)

Symbol	Parameter	UM621024C-55L/70L		UM621024C-55LL/70LL		Unit	Conditions
		Min.	Max.	Min.	Max.		
I _{CC1}	Dynamic Operating Current	-	70	-	70	mA	Min. Cycle, Duty = 100% CE ₁ = V _{IL} , CE ₂ = V _{IH} I _{I/O} = 0 mA
I _{CC2}		-	15	-	15	mA	CE ₁ = V _{IL} , CE ₂ = V _{IH} V _{IH} = V _{CC} , V _{IL} = 0V f = 1 MHz, I _{I/O} = 0 mA
I _{SB}	Standby Power Supply Current	-	3	-	2	mA	CE ₁ = V _{IH} or CE ₂ = V _{IL}
I _{SB1}		-	100	-	25	μA	CE ₁ ≥ V _{CC} - 0.2V CE ₂ ≥ V _{CC} - 0.2V V _{IN} ≥ 0V
I _{SB2}		-	100	-	25	μA	CE ₂ ≤ 0.2V V _{IN} ≥ 0V
V _{OL}	Output Low Voltage	-	0.4	-	0.4	V	I _{OL} = 2.1 mA
V _{OH}	Output High Voltage	2.4	-	2.4	-	V	I _{OH} = -1.0 mA

Truth Table

Mode	CE ₁	CE ₂	OE	WE	I/O Operation	Supply Current
Standby	H	X	X	X	High Z	I _{SB} , I _{SB1}
	X	L	X	X	High Z	I _{SB} , I _{SB2}
Output Disabled	L	H	H	H	High Z	I _{CC} , I _{CC1} , I _{CC2}
Read	L	H	L	H	DOUT	I _{CC} , I _{CC1} , I _{CC2}
Write	L	H	X	L	DIN	I _{CC} , I _{CC1} , I _{CC2}

Note: X: H or L

Capacitance (T_A = 25°C, f = 1.0 MHz)

Symbol	Parameter	Min.	Max.	Unit	Conditions
C _{IN} *	Input Capacitance		6	pF	V _{IN} = 0V
C _{I/O} *	Input/Output Capacitance		8	pF	V _{I/O} = 0V

* This parameter is sampled and not 100% tested.

AC Characteristics ($T_A = 0^\circ\text{C to } +70^\circ\text{C}, V_{CC} = 5\text{V} \pm 10\%$)

Symbol	Parameter	UM621024C-55L/LL		UM621024C-70L/LL		Unit	
		Min.	Max.	Min.	Max.		
Read Cycle							
t_{RC}	Read Cycle Time	55	-	70	-	ns	
t_{AA}	Address Access Time	-	55	-	70	ns	
t_{ACE1}	Chip Enable Access Time	$\overline{CE1}$	-	55	-	70	ns
t_{ACE2}		CE2	-	55	-	70	ns
t_{OE}	Output Enable to Output Valid	-	30	-	35	ns	
t_{CLZ1}	Chip Enable to Output in Low Z	$\overline{CE1}$	10	-	10	-	ns
t_{CLZ2}		CE2	10	-	10	-	ns
t_{OLZ}	Output Enable to Output in Low Z	5	-	5	-	ns	
t_{CHZ1}	Chip Disable to Output in High Z	$\overline{CE1}$	0	20	0	25	ns
t_{CHZ2}		CE2	0	20	0	25	ns
t_{OHZ}	Output Disable to Output in High Z	0	20	0	25	ns	
t_{OH}	Output Hold from Address Change	5	-	5	-	ns	
Write Cycle							
t_{WC}	Write Cycle Time	55	-	70	-	ns	
t_{CW}	Chip Enable to End of Write	50	-	60	-	ns	
t_{AS}	Address Setup Time	0	-	0	-	ns	
t_{AW}	Address Valid to End of Write	50	-	60	-	ns	

AC Characteristics (continued)

Symbol	Parameter	UM621024C-55L/LL		UM621024C-70L/LL		Unit
		Min.	Max.	Min.	Max.	
t_{WP}	Write Pulse Width	40	-	50	-	ns
t_{WR}	Write Recovery Time	0	-	0	-	ns
t_{WHZ}	Write to Output in High Z	0	25	0	30	ns
t_{DW}	Data to Write Time Overlap	25	-	30	-	ns
t_{DH}	Data Hold from Write Time	0	-	0	-	ns
t_{OW}	Output Active from End of Write	5	-	5	-	ns

Notes: t_{CHZ1} , t_{CHZ2} and t_{OHZ} and t_{WHZ} are defined as the time at which the outputs achieve the open circuit condition and are not referred to output voltage levels.

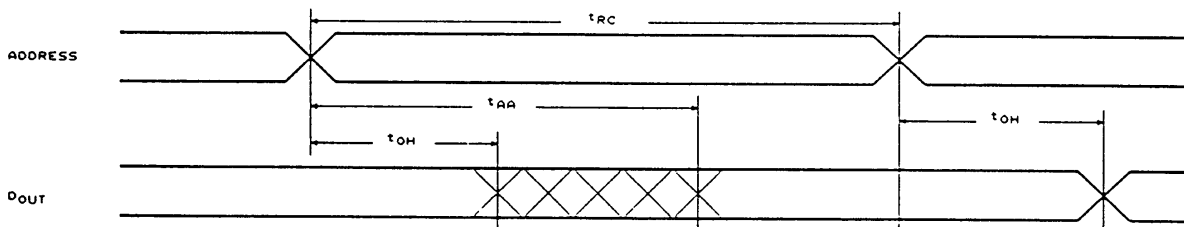
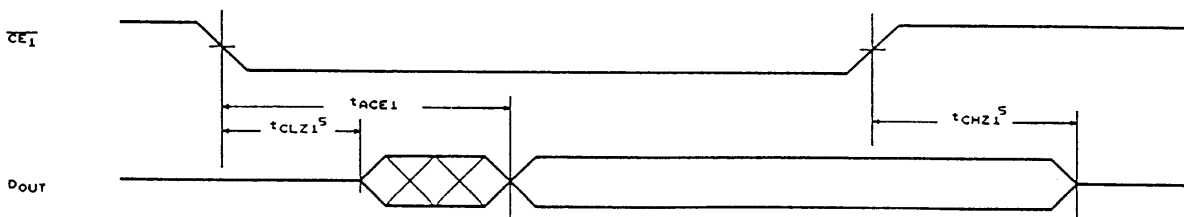
Timing Waveforms
Read Cycle 1^(1, 2, 4)

Read Cycle 2^(1, 3, 4, 6)

Ordering Information

Part No.	Access Time (ns)	Operating Current Max. (mA)	Standby Current Max. (μ A)	Package	
UM621024C-70L	70	70	100	32L DIP	
UM621024C-70LL		70	25	32L DIP	
UM621024CM-70L		70	100	32L SOP	
UM621024CM-70LL		70	25	32L SOP	
UM621024CV-70L		70	100	32L TSOP	
UM621024CV-70LL		70	25	32L TSOP	
UM621024CVR-70L		70	100	32L TSOP	
UM621024CVR-70LL		70	25	32L TSOP	
UM621024C-10L		100	70	100	32L DIP
UM621024C-10LL			70	25	32L DIP
UM621024CM-10L	70		100	32L SOP	
UM621024CM-10LL	70		25	32L SOP	
UM621024CV-10L	70		100	32L TSOP	
UM621024CV-10LL	70		25	32L TSOP	
UM621024CVR-10L	70		100	32L TSOP	
UM621024CVR-10LL	70		25	32L TSOP	

Package Information
DIP 32L Outline Dimensions

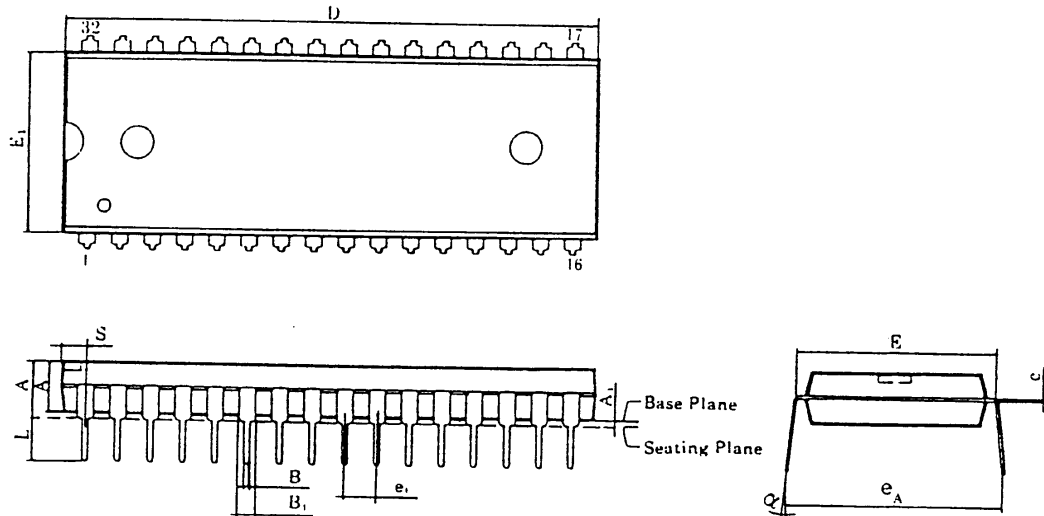
Unit: inches/mm



Symbol	Dimensions in inches	Dimensions in mm
A	0.210 Max.	5.33 Max.
A ₁	0.010 Min.	0.25 Min.
A ₂	0.155±0.010	3.94±0.25
B	0.018 ^{+0.004} / _{-0.002}	0.46 ^{+0.10} / _{-0.05}
B ₁	0.050 ^{+0.004} / _{-0.002}	1.27 ^{+0.10} / _{-0.05}
C	0.010 ^{+0.004} / _{-0.002}	0.25 ^{+0.10} / _{-0.05}
D	1.650 Typ. (1.670 Max.)	41.91 Typ. (42.42 Max.)
E	0.600±0.010	15.24±0.25
E ₁	0.550 Typ. (0.562 Max.)	13.97 Typ. (14.27 Max.)
e ₁	0.100±0.010	2.54±0.25
L	0.130±0.010	3.30±0.25
α	0° - 15°	0° - 15°
e _A	0.655±0.035	16.64±0.89
S	0.090 Max.	2.29 Max.

Notes:

1. The maximum value of dimension D includes end flash.
2. Dimension E₁ does not include resin fins.
3. Dimension S includes end flash.

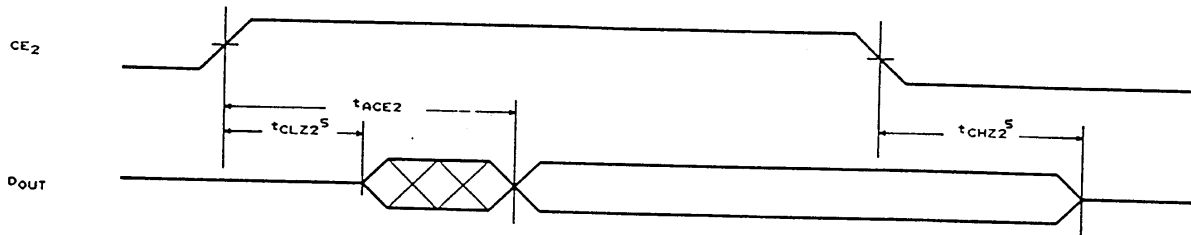
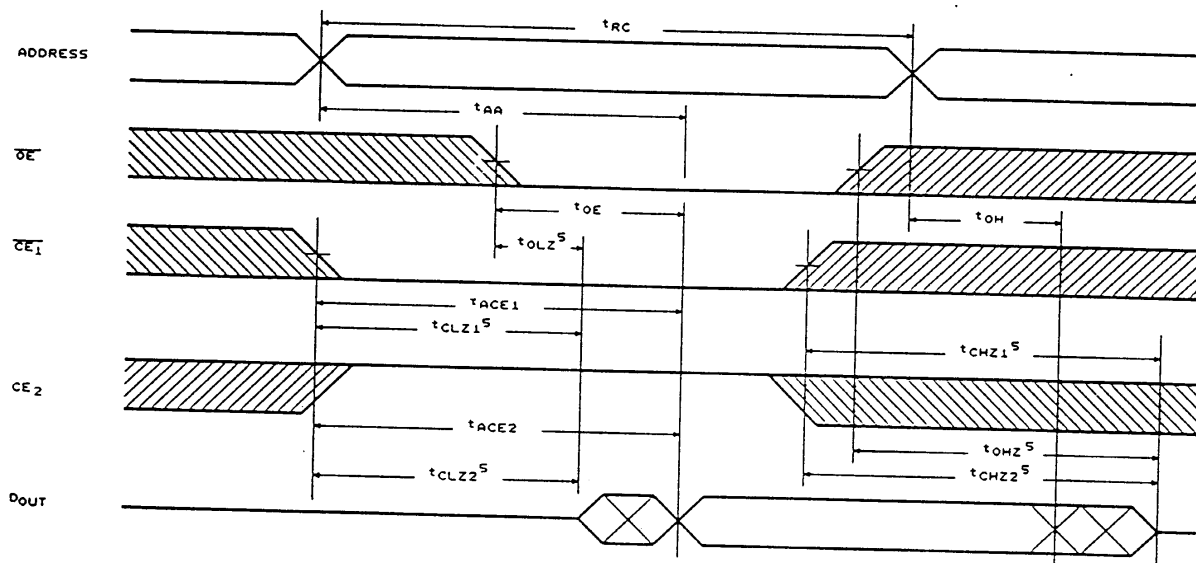
Timing Waveforms (continued)
Read Cycle 3^(1, 4, 7, 8)

Read Cycle 4⁽¹⁾

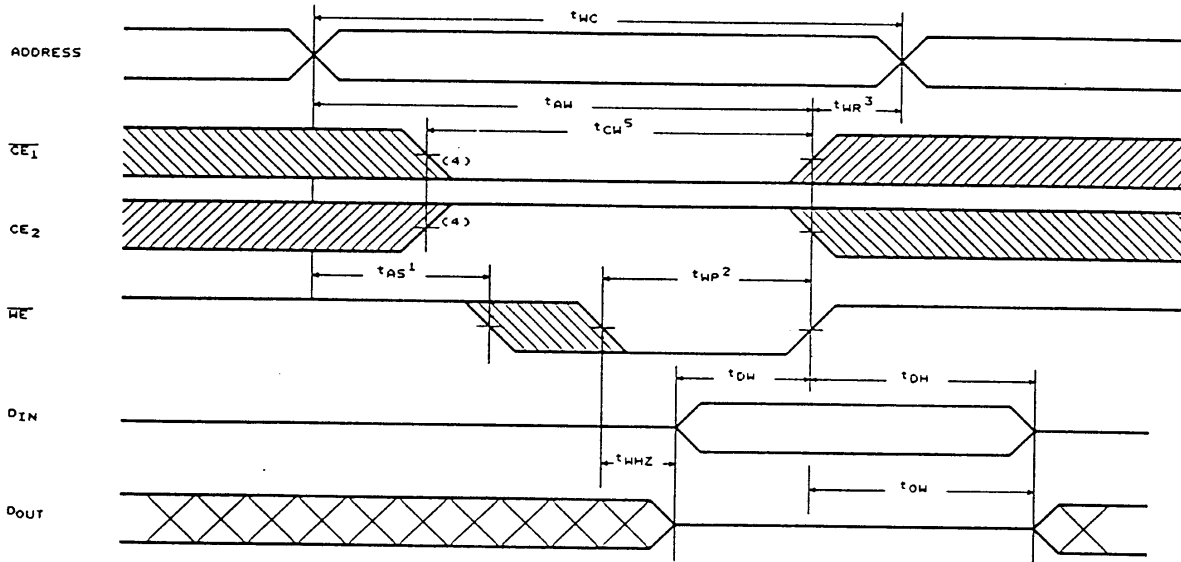
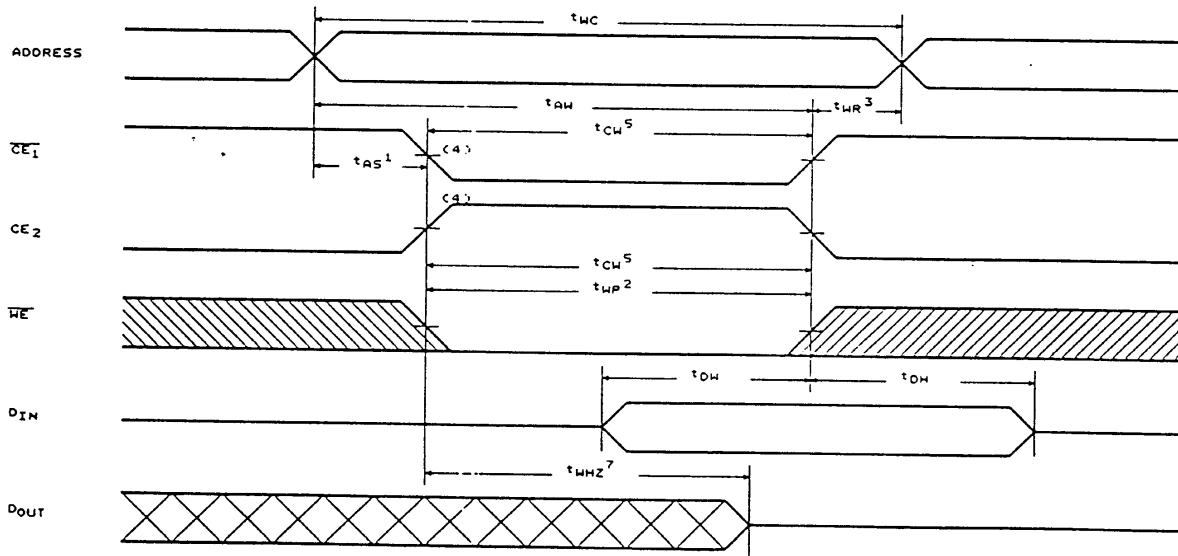
- Notes:
1. \overline{WE} is high for Read Cycle.
 2. Device is continuously enabled $\overline{CE1} = V_{IL}$ and $CE2 = V_{IH}$.
 3. Address valid prior to or coincident with $\overline{CE1}$ transition low.
 4. $\overline{OE} = V_{IL}$
 5. Transition is measured $\pm 500\text{mV}$ from steady state. This parameter is sampled and not 100% tested.
 6. $CE2$ is high.
 7. $\overline{CE1}$ is low.
 8. Address valid prior to or coincident with $CE2$ transition high.

Timing Waveforms (continued)
**Write Cycle 1 ⁽⁶⁾
(Write Enable Controlled)**

**Write Cycle 2
(Chip Enable Controlled)**

- Notes:
1. t_{AS} is measured from the address valid to the beginning of write.
 2. A write occurs during the overlap (t_{WP}) of a low $\overline{CE1}$, a high $CE2$ and a low \overline{WE} .
 3. t_{WR} is measured from the earliest of $\overline{CE1}$ or \overline{WE} going high or $CE2$ going low to the end of write cycle.
 4. If the $\overline{CE1}$ low transition or the $CE2$ high transition occurs simultaneously with the \overline{WE} low transition, outputs remain in a high impedance state.
 5. t_{CW} is measured from the later of $\overline{CE1}$ going low or $CE2$ going high to the end of write.
 6. \overline{OE} is continuously low. ($\overline{OE} = V_{IL}$)
 7. Transition is measured $\pm 500\text{mV}$ from steady state. This parameter is sampled and not 100% tested.

AC Test Conditions

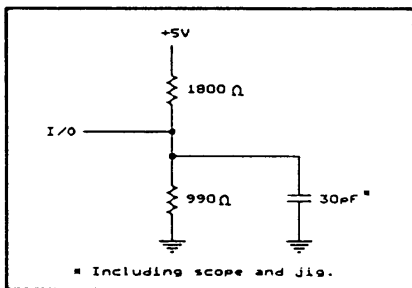
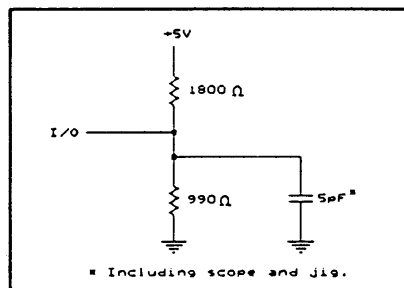
Input Pulse Levels	0V to 3.0V
Input Rise and Fall Time	5 ns
Input and Output Timing Reference Levels	1.5V
Output Load	See Fig. 1, 2

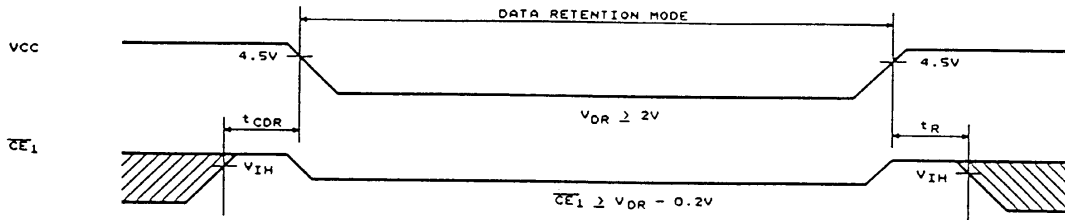
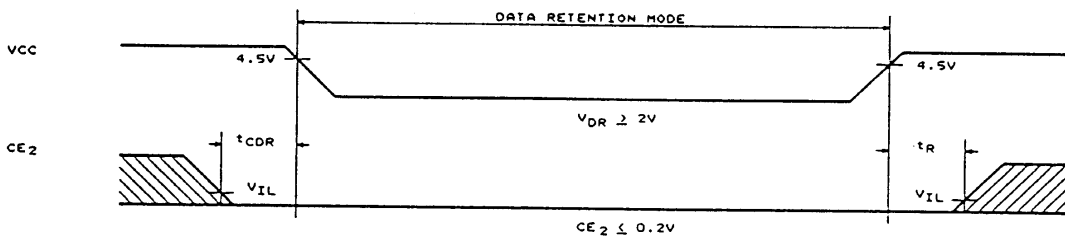

Figure 1. Output Load

Figure 2. Output Load for t_{CLZ1} , t_{CLZ2} , t_{OLZ} , t_{CHZ1} , t_{CHZ2} , t_{OHZ} , t_{WHZ} , and t_{OW}
Data Retention Characteristics ($T_A = 0^\circ\text{C}$ to 70°C)

Symbol	Parameter	Min.	Max.	Unit	Conditions
VDR1	VCC for Data Retention	2.0	5.5	V	$\overline{CE1} \geq VCC - 0.2V$
VDR2		2.0	5.5	V	$\overline{CE2} \leq 0.2V$ $\overline{CE1} \geq VCC - 0.2V$ or $\overline{CE1} \leq 0.2V$
ICCDR1	Data Retention Current	L-Version	-	50*	μA $VCC = 3.0V$ $\overline{CE1} \geq VCC - 0.2V$ $\overline{CE2} \geq VCC - 0.2V$ $V_{IN} \geq 0V$
		LL-Version	-	10**	
ICCDR2	Data Retention Current	L-Version	-	50*	μA $VCC = 3.0V$ $\overline{CE2} \leq 0.2V$ $V_{IN} \geq 0V$
		LL-Version	-	10**	
t_{CDR}	Chip Disable to Data Retention Time	0	-	ns	See Retention Waveform
t_R	Operation Recovery Time	5	-	ms	

****** UM621024C-70LL/10LL

 ICCDR: Max. 3 μA at $T_A = 0^\circ\text{C}$ to $+40^\circ\text{C}$
***** UM621024C-70L/10L

 ICCDR: Max. 20 μA at $T_A = 0^\circ\text{C}$ to $+40^\circ\text{C}$

Low VCC Data Retention Waveform (1) (\overline{CE}_1 Controlled)

Low VCC Data Retention Waveform (2) (CE_2 Controlled)

Package Information
SOIP 32L Outline Dimensions

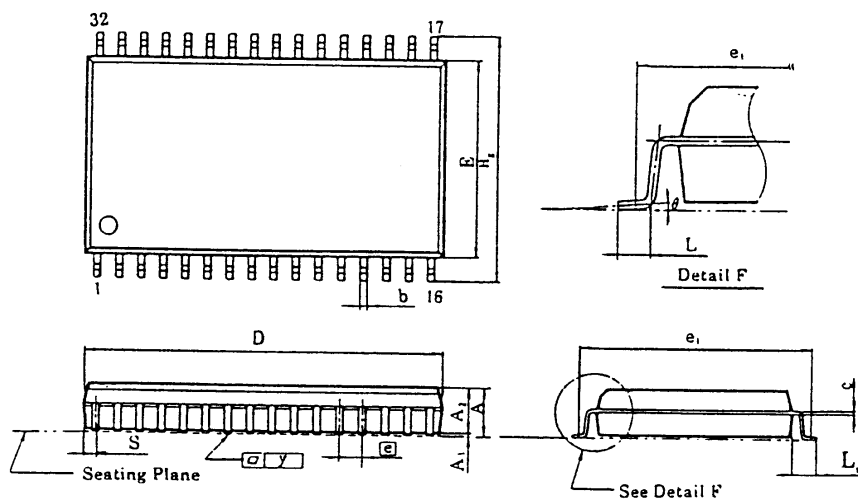
Unit: inches/mm



Symbol	Dimensions in inches	Dimensions in mm
A	0.118 Max.	3.00 Max.
A ₁	0.004 Min.	0.10 Min.
A ₂	0.106±0.005	2.69±0.13
b	0.016 ^{+0.004} _{-0.002}	0.41 ^{+0.10} _{-0.05}
C	0.008 ^{+0.004} _{-0.002}	0.20 ^{+0.10} _{-0.05}
D	0.805 Typ. (0.820 Max.)	20.45 Typ. (20.83 Max.)
E	0.445±0.010	11.30±0.25
e	0.050±0.006	1.27±0.15
e ₁	0.525 NOM.	13.34 NOM.
H _ε	0.556±0.010	14.12±0.25
L	0.031±0.008	0.79±0.20
L _ε	0.055±0.008	1.40±0.20
S	0.044 Max.	1.12 Max.
y	0.004 Max.	0.10 Max.
θ	0° - 10°	0° - 10°

Notes:

1. The maximum value of dimension D includes end flash.
2. Dimension E does not include resin fins.
3. Dimension e₁ is for PC Board surface mount pad pitch design reference only.
4. Dimension S includes end flash.

Package Information
TSOP 32L Outline Dimensions

Unit: inches/mm

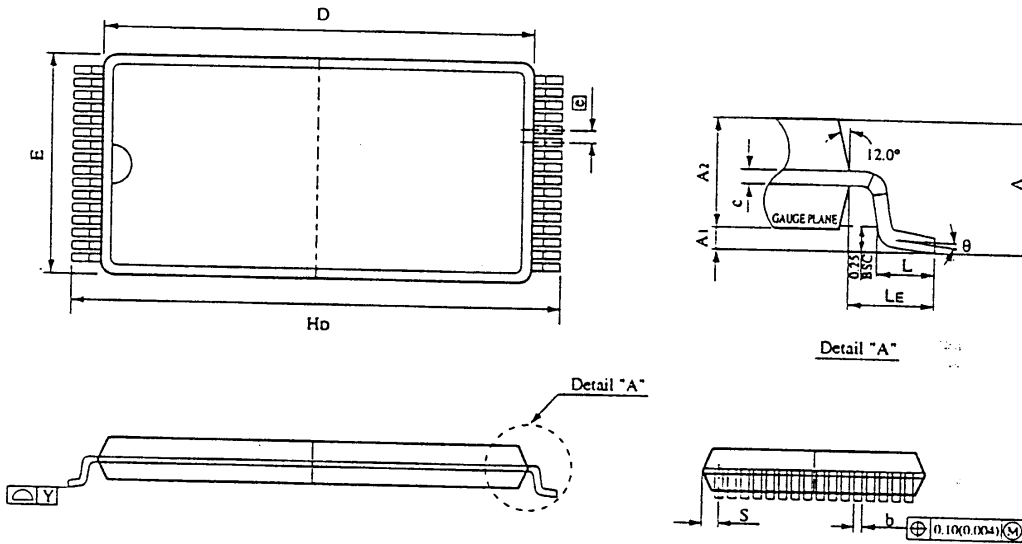

Symbol	Dimensions in inches	Dimensions in mm
A	0.047 Max.	1.20 Max.
A ₁	0.004±0.002	0.10±0.05
A ₂	0.039±0.002	1.00±0.05
b	0.008±0.001	0.20±0.03
c	0.006±0.001	0.15±0.02
D	0.724±0.004	18.40±0.10
E	0.315±0.004	8.00±0.10
e	0.020 TYP.	0.50 TYP.
Ho	0.787±0.007	20.00±0.20
L	0.020±0.004	0.50±0.10
LE	0.031 TYP.	0.80 TYP.
S	0.0167 TYP.	0.425 TYP.
Y	0.004 Max.	0.10 Max.
θ	0° - 6°	0° - 6°

Notes:

1. The maximum value of dimension D includes end flash.
2. Dimension E does not include resin fins.
3. Dimension e1 is for PC Board surface mount pad pitch design reference only.
4. Dimension S includes end flash.

UNITED MICROELECTRONICS CORPORATION ("UMC")
TERMS AND CONDITIONS OF SALE
(Revision: November 1994)

ARTIES

- a) Except as provided in paragraph 0(c) below, the term "UMC" as used here refers to one of United Microelectronics Corporation, the Taiwan corporation, United Microelectronics (Europe) B.V., UMC K.K., or United Microelectronics Company Ltd., whichever of these sends the invoice to Buyer for the product involved.
- b) Buyer expressly acknowledges that United Microelectronics Corporation, a Taiwan corporation, is a separate and distinct entity from United Microelectronics (Europe) B.V., from UMC K.K., and from United Microelectronics Company Ltd. Buyer agrees that its sole and exclusive agreement is with United Microelectronics (Europe) B.V. or UMC K.K. or United Microelectronics Company Ltd., or with some other non-UMC company, and that it has received no representations from, that it has no agreement with, and that it holds no obligations from or rights against United Microelectronics Corporation, the Taiwan corporation.
- c) Buyer agrees that the provisions of paragraphs 4(b)-(g), 5, 6, 8, 9, 10 and 13 extend to and include United Microelectronics Corporation, the Taiwan corporation, as well as United Microelectronics (Europe) B.V., UMC K.K., and United Microelectronics Company Ltd.

ACCEPTANCE OF TERMS

BUYER ACCEPTS THESE TERMS (I) BY WRITTEN ACCEPTANCE (BY PURCHASE ORDER OR OTHERWISE), OR (II) BY FAILURE TO RETURN GOODS DESCRIBED ON FACE OF THIS FORM WITHIN FIVE DAYS OF THEIR DELIVERY.

DELIVERY

- () Delivery will be as stated in UMC's quotation, or if none are stated, Free Carrier (Incoterms 1990) UMC's warehouse.
- () Title to the goods and the entire risk will pass to Buyer upon delivery to carrier.
- () Shipments are subject to availability. UMC shall make every reasonable effort to meet the date(s) quoted or acknowledged; and if UMC makes such effort, UMC will not be liable for any delays.

TERMS OF PAYMENT

- () Terms are as stated on UMC's quotation, or if none are stated, Letter of Credit at sight. Accounts past due will incur a monthly charge at the rate of one and one-half percent (1.5%) per month (or, if less, the maximum allowed by applicable law) to cover servicing costs.
- () UMC reserves the right to change credit terms at any time in its sole discretion.

LIMITED WARRANTY

UMC warrants that the goods sold will be free from defects in material and workmanship and comply with UMC's applicable published specifications for a period of sixty (60) days from date of UMC's shipment. Goods or parts which have been subject to abuse, misuse, accident, alteration, neglect, or unauthorized repair or improper application are not covered by any warranty. No warranty is made with respect to custom products or goods produced to Buyer's specifications (unless specifically stated in a writing signed by UMC). No warranty is made with respect to goods used in devices intended for use in applications where failure to perform when properly used can reasonably be expected to result in significant injury (including, without limitation, navigation, aviation or nuclear equipment, or for surgical implant or to support or sustain life) and Buyer agrees to indemnify, defend, and hold harmless UMC from all claims, damages and liabilities arising out of any such uses. This Paragraph 4 is the only warranty by UMC with respect to goods and may not be modified or amended except in writing signed by an authorized officer of UMC and by Buyer.

Buyer acknowledges and agrees that it is not relying on any applications or circuits in product literature, and Buyer will test all parts and applications under extended field and laboratory conditions. Notwithstanding any cross-reference or any statements of compatibility, functionality, and the like, UMC's goods may differ from those of others with respect to performance, function and/or operation, with respect to areas not expressly stated in written specifications for UMC's goods, and with respect to ranges outside those specifications; and Buyer agrees that UMC makes no warranties and is not responsible for such things.

EXCEPT AS PROVIDED ABOVE, UMC MAKES NO WARRANTIES OR CONDITIONS, EXPRESS, IMPLIED, OR STATUTORY, AND EXPRESSLY EXCLUDES AND DISCLAIMS ANY WARRANTY OR CONDITION OF MERCHANTABILITY OR FITNESS FOR A PARTICULAR PURPOSE OR APPLICATION.

UMC has no sales or service functions in the U.S.A. and therefore does not intend to sell, and does not imply that it licenses sale of its products in or to the U.S.A.

LIMITATION OF LIABILITY

UMC will not be liable for any loss, damage or penalty resulting from causes beyond its reasonable control, including but not limited to delay by others, force majeure, act of God, or labor conditions. In any such event, the date(s) for UMC's performance will be deemed extended for a period equal to any delay resulting. UMC'S LIABILITY ARISING OUT OF THIS CONTRACT OR ANY GOODS SOLD

WILL BE LIMITED TO REFUND OF THE PURCHASE PRICE OR REPAIR OR REPLACEMENT OF PURCHASED GOODS (RETURNED TO UMC FREIGHT PRE-PAID).

- (c) Buyer will not return any goods without first obtaining a customer return order number.
- (d) AS A SEPARATE LIMITATION, IN NO EVENT WILL UMC BE LIABLE FOR COSTS OF SUBSTITUTE GOODS; FOR ANY SPECIAL, CONSEQUENTIAL, INCIDENTAL OR INDIRECT DAMAGES; OR LOSS OF USE, OPPORTUNITY, MARKET POTENTIAL, AND/OR PROFIT ON ANY THEORY (CONTRACT, TORT, FROM THIRD PARTY CLAIMS OR OTHERWISE). THESE LIMITATIONS SHALL APPLY NOTWITHSTANDING ANY FAILURE OF ESSENTIAL PURPOSE OF ANY REMEDY.
- (e) No action against UMC, whether for breach, indemnification, contribution or otherwise, shall be commenced more than one year after the cause of action has accrued, or more than one year after either the Buyer, user or other person knew or with reasonable diligence should have known of the matter or of any claim of dissatisfaction or defect involved; and no such claim may be brought unless UMC has first been given commercially reasonable notice, a full written explanation of all pertinent details, and a good faith opportunity to resolve the matter.
- (f) BUYER EXPRESSLY AGREES TO THE LIMITATIONS OF THIS PARAGRAPH 5 AND TO THEIR REASONABLENESS.

6. SUBSTITUTIONS AND MODIFICATIONS

UMC may at any time make substitutions and modifications to products which do not materially and adversely affect overall product performance within the then current UMC specifications in the typical and intended use. In addition, UMC reserves the right to halt production or alter specifications and prices at any time without notice. Buyer agrees to verify that the data sheets and other information are current before placing orders.

7. CANCELLATION

- (a) This contract may not be cancelled by Buyer except with written consent by UMC and Buyer's payment of reasonable cancellation charges (including but not be limited to expenses already incurred for labor and material, overhead, commitments made by UMC, and a reasonable profit).
- (b) In no event will Buyer have rights in partially completed goods.

8. INDEMNIFICATION

UMC will, at its own expense, defend and/or settle all suits against Buyer to the extent based on any valid claim that any parts as shipped by UMC under this purchase order infringe any valid, enforceable, unexpired P.O.C. patent, copyright or trademark provided, however, that Buyer (i) gives immediate written notice to UMC, (ii) permits UMC to defend, and (iii) gives UMC all needed information, assistance, and authority. However, UMC will not be responsible for infringements resulting from anything not manufactured entirely by UMC, or from any combination with products, equipment or materials not furnished by UMC. UMC shall have no liability under this Paragraph 8 for any products made to Buyer's specifications, code, or design. THIS PARAGRAPH STATES UMC'S ENTIRE LIABILITY AND OBLIGATION WITH RESPECT TO INTELLECTUAL OR INDUSTRIAL PROPERTY INFRINGEMENT OR CLAIMS THEREFORE. Except as to claims UMC agrees to defend, BUYER WILL INDEMNIFY, DEFEND AND HOLD HARMLESS UMC FROM ALL CLAIMS, COSTS, LOSSES, AND DAMAGES (INCLUDING ATTORNEYS' FEES) AGAINST AND/OR ARISING OUT OF GOODS SOLD AND/OR SHIPPED HEREUNDER.

9. NO CONFIDENTIAL INFORMATION

UMC shall have no obligation to hold any information in confidence except as provided in a separate non-disclosure agreement signed by both parties.

10. ENTIRE AGREEMENT

- (a) These terms and conditions are the entire agreement between UMC and Buyer, and no addition, deletion or modification shall be binding on UMC unless expressly agreed to in a writing signed by an officer of UMC.
- (b) Buyer is not relying upon any warranty or representation except for those specifically stated here.

11. APPLICABLE LAW

This contract and all performance and disputes arising out of or relating to goods involved will be governed by the laws of Taiwan, Republic of China, without reference to conflict of laws principles and excluding the U.N. Convention on Contracts for the International Sale of Goods. Buyer agrees at its sole expense to comply with all applicable laws in connection with the purchase, use or sale of the goods provided hereunder.

12. JURISDICTION AND VENUE

The courts located in Taiwan, Republic of China, will have the sole and exclusive jurisdiction and venue over any dispute arising out of or relating to this contract or any sale of goods hereunder, and Buyer hereby consents to the jurisdiction of such courts.

13. ATTORNEYS' FEES

Reasonable attorneys' fees and costs will be awarded to the prevailing party in the event of litigation involving the enforcement or interpretation of this contract.



UNITED MICROELECTRONICS CORPORATION

CORPORATE HEADQUARTERS:

NO.13, INNOVATION RD. I, SCIENCE-BASED INDUSTRIAL PARK, HSINCHU CITY, TAIWAN, R.O.C.

SALES OFFICE:

8F, NO.233-1, BAO CHIAO ROAD, HSIN TIEN, TAPEI COUNTY, TAIWAN, R.O.C.
TEL: 886-2-918-1589 FAX: 886-2-918-0188, 918-0068

OFFSHORE BRANCHES:

UNITED MICROELECTRONICS (EUROPE) B.V.

HOEKENRODE 2, 1102 BR AMSTERDAM ZUIDOOST, THE NETHERLANDS
TEL: 31-20-697-0766 (3 LINES) FAX: 31-20-697-7826 TLX: 11677 UMC NL

UMCK.K.

7F, T.T.D. BLDG. 1-2-18, MITA, MINATO-KU, TOKYO, 108, JAPAN
TEL: 81-3-3455-8306 FAX: 81-3-3455-8307

UNITED MICROELECTRONICS COMPANY LTD.

RM.1003, TOWER B, HUNGHOM COMMERCIAL CENTRE,
37 MA' TAU WAI RD., HUNGHOM, KOWLOON, H.K.
TEL: 852-2765-7122 FAX: 852-2765-7483

**UNITED MICROELECTRONICS CO., LTD.
(SINGAPORE REPRESENTATIVE OFFICE)**

DBS SECURITIES BUILDING
22 MAIACCA STREET #14-02, SINGAPORE 0104
TEL: 65-536-8865 FAX: 65-536-8875

REPRESENTING UMC

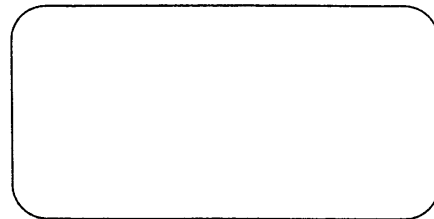

UMC © 1995
All rights reserved
Copying prohibited

PM9601V1
Printed in Taiwan, R.O.C.
January 1996