

## ➤ GENERAL DESCRIPTION:

The AVH316B, AVH316C, AVH316D, AV0716C, AV0716D, AV1416D, AV2116A, AV2816A is a single-chip synthesizing CMOS VLSI that can synthesize voice up to 3.5,7,14,21,28 seconds using APLUS qualified coding algorithm (LOGPCM).

Customer speech data will be edited and programmed into ROM by changing one mask during one mask during the device fabrication.

## ➤ FEATURES:

1. Single power supply can operate from 2.4v through 5v.

2. The total voice duration is about 3.5,7,14,21,28,42 seconds could be partitioned up to 16 voice sections.

Each voice section could have 4 playing lengths; the longest one is the original voice+mute length.

3. Voice + mute length could up to 22 seconds ( 11 seconds in AVH316 ) (6k sampling rate) for each voice section.

4. One 112 voice-steps table, could be partitioned up to 16 subtables of steps.

5. 5 mask option of playback speed : 1> 4.3K ; 2> 5.0K ; 3> 6.0K ; 4> 7.5K ; 5> 10.0K ( Hz )

6. 1 trigger input (TG): with resistive schmitt input (270K—1M) for CDS interface.

sequential function : once the input was triggered sequentially the device will response by one subtable of voice\_step

sequentially and cyclically , from subtable\_m ( m= 1 -16 ) to user defined subtable\_n ( n= 1 - 16 ) .

random function : Once the input was trigger , the device will response from subtable\_m ( m: 1 - 16 ) to subtable\_n

( n: 1 - 16 ) at random .

snooze function : use 2 subtables : 1st stores ringing voice , playing when time's up.

2nd stores ( greeting sound + ) snooze time .

7. Has two debounce time : 10 ms, 50 us. with following mask option

A>50us B>10ms C>IO1(VDD-50us,GND-10ms) D>IO2(VDD-50us,GND-10ms) E>IO3(VDD-50us,GND-10ms)

C,D,E;could only be selected when IO1,IO2,IO3 are mask\_option as control input .

8. Automatic Rosc selection : enable - the device will use external Rosc if it has external Rosc ; the device will use internal Rosc

automatically if it hasn't external Rosc . ( It must be determined before operation )

disable - use external Rosc only . IO2 - VDD : disable GND : enable

Internal Rosc options : (mask option)

For **VH316B, AVH316C, AVH316D, AV0716C, AV0716D, AV1416D, AV2116A, AV2816A** :

playback speed(khz)	A	B	C	D	E	F	G	H	I	J	K	L	M
4.3	8.9	8.6	7.9	7	6.3	5.8	5.4	5.1	4.7	4.3	4.1	3.9	3.6
5	10.3	10	9.2	8.2	7.3	6.8	6.3	5.9	5.5	5	4.8	4.6	4.2
6	12.4	12	11	9.8	8.8	8.1	7.5	7.1	6.6	6	5.7	5.5	5
7.5	15.5	15	13.8	12.3	11	10.1	9.4	8.9	8.3	7.5	7.1	6.9	6.3
10	20.7	20	18.3	16.3	14.7	13.5	12.5	11.8	11	10	9.5	9.2	8.3

9. Playing mode :EDGE/LEVEL , HOLD/UNHOLD , RETRIGGER/IRRETRIGGER with following mask options :

EDGE/LEVEL	HOLD/UNHOLD	RETRIGGERING/IRRETRIGGER
A>EDGE	A>HOLD	A>IRRETRIGGER
B>LEVEL	B>UNHOLD	B>RETRIGGER
C>IO1(VDD-edge,GND-level)	C>IO1(VDD-hold,GND-unhold)	C>IO1(VDD-irretrigger,GND-retrigger)
D>IO2(VDD-edge,GND-level)	D>IO2(VDD-hold,GND-unhold)	D>IO2(VDD-irretrigger,GND-retrigger)
E>IO3(VDD-edge,GND-level)	E>IO3(VDD-hold,GND-unhold)	E>IO3(VDD-irretrigger,GND-retrigger)

C, D, E could only be selected when IO1,IO2,IO3 are mask\_option as control input .

10. 3 I/O PINS WITH FOLLOWING OPTIONS:

* IO1	* IO2	* IO3
A>COUT B>STOPH C>STOPL	A>PWM1 B>STOPH C>STOPL	A>PWM2 B>STOPH C>STOPL
D>BUSYH E>BUSYL F>6HZ	D>BUSYH E>BUSYL F>6HZ	D>BUSYH E>BUSYL F>6HZ
G>DYNA1/4 H>DYN2/4 I>DYN3/4	G>DYNA1/4 H>DYN2/4 I>DYN3/4	G>DYNA1/4 H>DYN2/4 I>DYN3/4
J>USED AS CONTROL INPUT	J>USED AS CONTROL INPUT	J>USED AS CONTROL INPUT

Item\_F : 0.75Hz or 1.5Hz or 3Hz or 6Hz(mask option)

Item\_B-I : with one subtable enable status option for IO1, IO2, IO3.

COUT : 3 current output levels, with 4 mask options (1.5mA;3mA;4.5mA;IO3<GND-3mA,VDD-4.5mA>).

PWM1, PWM2 : must be selected on the same time ,direct driving buzzer or 8 or 32 or 64 ohm speaker.

STOPH, STOPL : 40 ms high/low output when device stop playing.(drive 1.8 mA,sink 10mA;3v).

BUSYH, BUSYL : high/low output during device playing (drive 1.8 mA,sink 10mA;3v).

6Hz/3Hz, DYNA1/4, 2/4, 3/4 : LED driving. (drive 1.8 mA, sink 10mA;3v)

Used as control input : internal pull GND (0.5uA,3V)

For all the IO options : the dynamic should choice same level.

If IO2 and IO3 are both at 6Hz(3Hz), they will flash alternatively.

When used as control input, they could be used to control following options by bonding or toggle switch.

EDGE/LEVEL, HOLD/UNHOLD, RETRIGGER/IRRETRIGGER, DEBOUNCE 10ms/50us

● 一般規格:

**AVH316B ,AVH316C ,AVH316D ,AV0716C ,AV0716D ,AV1416D ,AV2116A,AV2816A** 乃一單晶片CMOS VLSI語音合成器，它以LOGPCM編碼方式，合成長達3.5、7、14、21、28、42 秒之語音。藉由製造過程中更換光罩，將客戶需要之語音資料編寫入ROM中。

● 特性：

1. 單一工作電壓範圍為2.4-5 伏特。
2. 語音總長度可達3.5、7、14、21、28、42秒，且可被分割成16語音段(section)，每段長度可不同。每一語音段有四種不同播放時間的選擇，但是任何一種播放時間皆不可長於原段的(語音+靜音)時間。

- 其中每一語音段的長度 (語音+靜音時間) 最多可達22秒(11秒in AVH316)。(在6kHz取樣頻率下)
- 具有112個語音格(VOICE - STEPS)，可規劃成16語音組(subtable)。
- 5種播放速度: 1>4.3k ; 2>5k ; 3>6k ; 4>7.5k ; 5>10k Hz
- 單鍵觸發(TG)：內含電阻式史密特輸入(270K-1M)提供光敏電阻(CDS)使用。
  - 順序觸發 (SEQUENTIAL)：一經觸發將由語音組(subtable) 1 至設定之語音組 (subtable n;n=1 - 16)每次觸發播放一組按順序循環播放。
  - 隨機觸發(RANDOM)：一經觸發將由設定第m語音組 (m由光罩選擇)至第n語音組(n由光罩選擇) 每次觸發播放一語音組, 按不規則播放。
  - 貪睡功能 (SNOOZE)：使用二個語音,語音組1 儲存時間到達時的鬧鈴聲音，語音組2 儲存聲音和貪睡時間
- 防止誤動作(DEBOUNCE)時間：10ms-提供一般手動操作, 50us-提供跳動開關使用, 以下選擇。
  - A>50us, B>10ms, C>IO1(VDD-50us,GND-10ms), D>IO2(VDD-50us,GND-10ms), E>IO3(VDD-50us,GND-10ms),
  - 選擇C,D,E 時,IO1,IO2,IO3須選擇為控制輸入
- 自動選擇振盪電阻(光罩選擇):
  - A). 致能 - 如果有接外部振盪電阻,則優先使用外部振盪電阻;如果沒有,則使用內部已選擇之振盪電阻(振盪電阻的狀態須在觸發前決定)。
  - B). 非致能 - 只能使用外部振盪電阻。
  - C). IO2控制輸入：VDD- 非致能；GND- 致能。
  - D). 內部振盪電阻選擇 (光罩選擇)：

For AVH316B,AVH316C,AVH316D,AV0716C,AV0716D,AV1416D,AV2116A,AV2816A:

振盪器項選擇	電阻選擇												
播放速度	A	B	C	D	E	F	G	H	I	J	K	L	M
4.3	8.9	8.6	7.9	7	6.3	5.8	5.4	5.1	4.7	4.3	4.1	3.9	3.6
5	10.3	10	9.2	8.2	7.3	6.8	6.3	5.9	5.5	5	4.8	4.6	4.2
6	12.4	12	11	9.8	8.8	8.1	7.5	7.1	6.6	6	5.7	5.5	5
7.5	15.5	15	13.8	12.3	11	10.1	9.4	8.9	8.3	7.5	7.1	6.9	6.3
10	20.7	20	18.3	16.3	14.7	13.5	12.5	11.8	11	10	9.5	9.2	8.3

### 9. 觸發模式的光罩選擇：

邊緣觸發 / 位準觸發 (EDGE / LEVEL)	保持 / 非保持 (HOLD / UNHOLD)	後段蓋前段 / 無後段蓋 前段 (RETRIGGER / IRRETRIGGER)
<input type="checkbox"/> 邊緣觸發 <input type="checkbox"/> 位準觸發 <input type="checkbox"/> IO1 (VDD-邊緣觸發, GND-位準觸發) <input type="checkbox"/> IO2 (VDD-邊緣觸發, GND-位準觸發) <input type="checkbox"/> IO3 (VDD-邊緣觸發, GND-位準觸發)	<input type="checkbox"/> 保持 <input type="checkbox"/> 非保持 <input type="checkbox"/> IO1 (VDD-保持, GND-非保持) <input type="checkbox"/> IO2 (VDD-保持, GND-非保持) <input type="checkbox"/> IO3 (VDD-保持, GND-非保持)	<input type="checkbox"/> 後段蓋前段 <input type="checkbox"/> 無後段蓋前段 <input type="checkbox"/> IO1(VDD-後段蓋前段,GND-無後段蓋前段) <input type="checkbox"/> IO2(VDD-後段蓋前段,GND-無後段蓋前段) <input type="checkbox"/> IO3(VDD-後段蓋前段,GND-無後段蓋前段)

※ 選擇C,D,E 時,IO1,IO2,IO3須選擇為控制輸入。

### 10.三個I/O PINS 有以下選擇：

<input type="checkbox"/> IO1的選擇	<input type="checkbox"/> IO2的選擇	<input type="checkbox"/> IO3的選擇
A) COUT 聲音輸出	A) PWM1 聲音輸出	A) .PWM2 聲音輸出
B) 停止播放時送出高位準脈衝.	B) 停止播放時送出高位準脈衝.	B) 停止播放時送出高位準脈衝.
C) 停止播放時送出低位準脈衝.	C) 停止播放時送出低位準脈衝.	C) 停止播放時送出低位準脈衝.
D) 播放時送出高位準訊號	D) 播放時送出高位準訊號	D) 播放時送出高位準訊號
E) 播放時送出低位準訊號	E) 播放時送出低位準訊號	E) 播放時送出低位準訊號
F) LED 6HZ 閃爍	F) LED 6HZ 閃爍	F) LED 6HZ 閃爍
G) LED 動態 1/4位準訊號	G) LED 動態 1/4位準訊號	G) LED 動態 1/4位準訊號
H) LED 動態 2/4位準訊號	H) LED 動態 2/4位準訊號	H) LED 動態 2/4位準訊號
I) LED 動態 3/4位準訊號	I) LED 動態 3/4位準訊號	I) LED 動態 3/4位準訊號
J) 控制輸入	J) 控制輸入	J) 控制輸入

第 F 項: 可選擇為LED 0.75Hz閃爍或為LED 1.5Hz閃爍或為LED 3Hz閃爍  
或為LED 6Hz閃爍。

第 B-I 項: 一組狀態致能選擇, 可由光罩選擇IO1, IO2及IO3對每一語音組(subtable)致能或非致能。

COUT: 3種電流輸出, 4種光罩選擇 (1.5mA, 3.0mA, 4.5mA, IO3<GND-3mA, VDD-4.5mA>)

PWM1、PWM2須同時選擇, 可驅動 buzzer 或 8、32、64 ohm speaker。

IO1、IO2及IO3為控制輸入時, 有一內部到地路徑(0.5uA, 3v)。

若IO1 - IO3同時選擇 LED動態位準訊號, 須選擇同一位準。

如IO2和IO3選擇相同LED 6HZ(3HZ)之狀態輸出時它們將交互閃爍。

IO1、IO2及IO3為控制輸入時, 可控制以下功能:

EDGE/LEVEL, HOLD/UNHOLD, RETRIGGER/IRRETRIGGER, DEBOUNCE 10ms/50us

### ● BLOCK DIAGRAM:

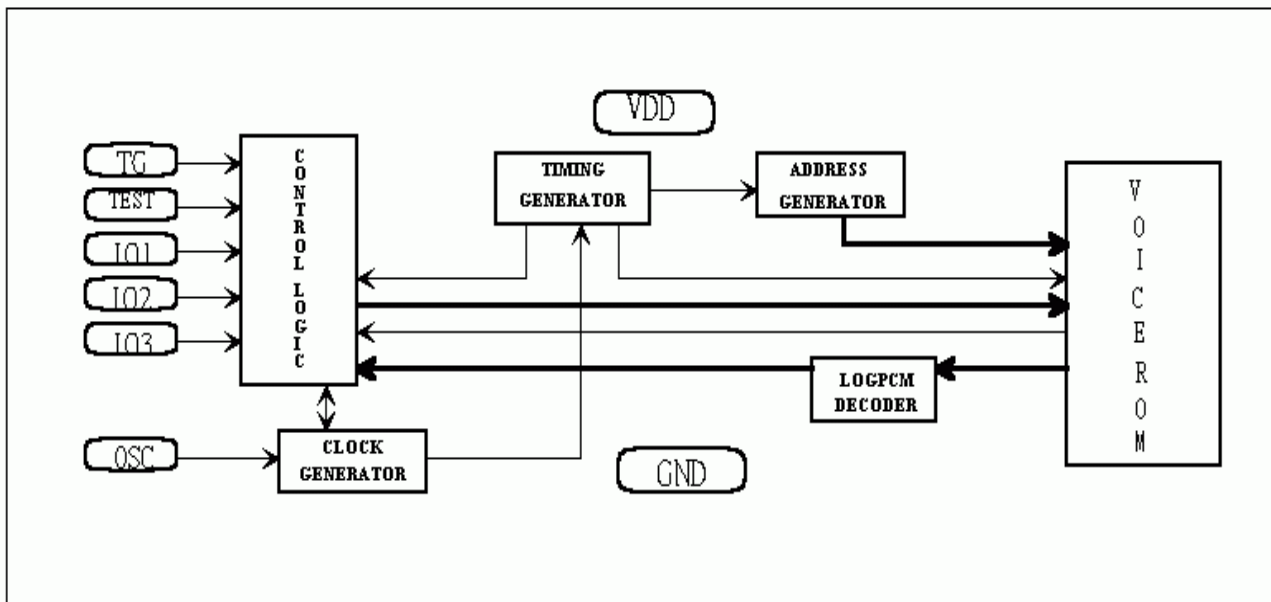

● PIN DESCRIPTION :

PADNAME	PIN ATTR.	FUNCTION
VDD	POWER	POSITIVE POWER SUPPLY.
OSC	I	OSCILLATOR INPUT (300K ohm CONNECT TO VDD).
TEST	I	TEST PAD, FOR PRODUCTION TESTING (TEST HIGH FOR TESTING)
TG	I	TRIGGER INPUT, INTERNAL PULL LOW (HIGH ACTIVE).
IO1,IO2,IO3	IO	AUDIO SIGNAL; STATUS OUTPUT; CONTROL INPUT.
VSS	POWER	NEGATIVE POWER SUPPLY.

● ABSOLUTE MAXIMUM RATING :

SYMBOL	RATING	UNIT
VDD-VSS	-0.5~+7.0	V
VIN (FOR ALL INPUT)	VSS-0.3<VIN<VDD+0.3	V
VOUT (FOR ALL OUTPUT)	GND<VOUT<VDD	V
T (OPERATING)	0~+70	°C
T (STORAGE)	-25~+75	°C

● DC CHARACTERISTICS :

SYMBOL	PARAMETER	MIN.	TYP.	MAX.	UNIT	CONDITION
VDD	OPERATING VOLTAGE	2.4	3	5	V	
I <sub>sb</sub>	SUPPLY CURRENT	STANDBY		0.1	uA	VDD=3V, I/O OPEN (WITH R <sub>osc</sub> )
I <sub>op</sub>		OPERATING		200		
I <sub>ih</sub>	TG		5		uA	VDD=3V
I <sub>il</sub>			0			
I <sub>co</sub>	IO1 USE AS CURRENT OUT (FULL SCALE)	-1.2	-1.5	-1.8	mA	VDD=3V, V O/P=0.7V
		-2.4	-3	-3.6		
		-3.6	-4.5	-5.4		
I <sub>ih</sub>	IO1,IO2,IO3 USE AS CONTROL INPUT		0	0.5	uA	VDD=3V
I <sub>il</sub>						
I <sub>oh</sub>	IO1,IO2,IO3 USE AS STATUS OUTPUT DURING OPERATING		min:-0.9 max:-1.4		mA	VDD=3V, V O/P=0V
I <sub>ol</sub>		8	10	12		
dF/F	FREQUENCY STABILITY	-10		10	%	$\frac{F_{osc}(3v)-F_{osc}(2.4v)}{F_{osc}(3v)}$
dF/F	F <sub>osc</sub> VARIATION	-10		10	%	VDD=3V, R <sub>osc</sub> =300K (R <sub>osc</sub> =180K in AV1416)

**3 > RANDOM :**

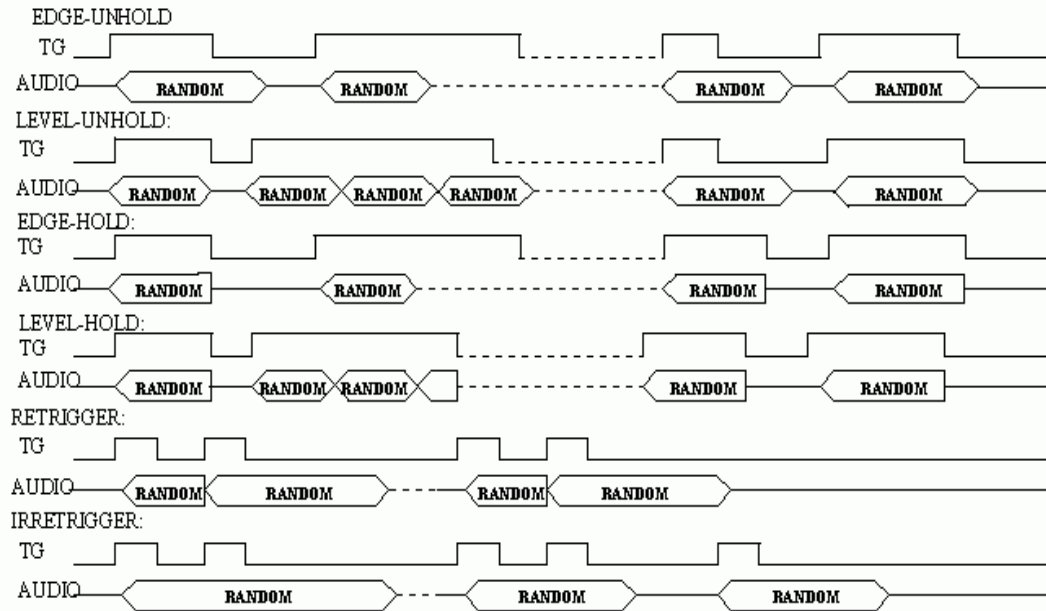

**4 > SNOOZE FUNCTION**

for application of snooze function , use subtable 1 , 2 only .

subtable - 1 : stores ringing voice , playing when time's up .

LHI trigger mode for alarm sound .

subtable - 2 : store greeting sound + snooze time ( special section - 0 + mute + .....until user defined snooze time ) .

special voice section - 0 must set as ' ramp down ' section .

EHI trigger type ( defined in device internally ) and STS output must set enable .

NOTE : ( 1 ) . this application could be used on both NON- LOCK and LOCK alarm clock .

( 2 ) . This application ( snooze function ) must use for power-on circuit , not for standby circuit .

( 3 ) . set sequential in random or sequential option .

Time is up

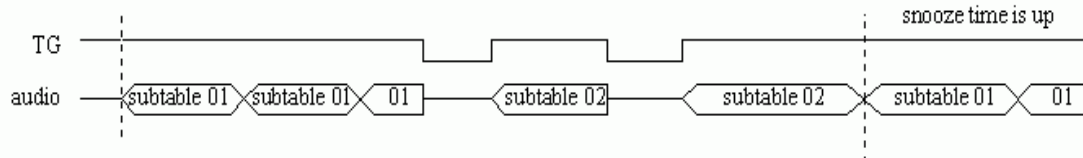

**APPLICATION CIRCUIT:**

**A> IO1 -- COUT ; IO2 -- LED ; IO3 -- CONTROL INPUT.**

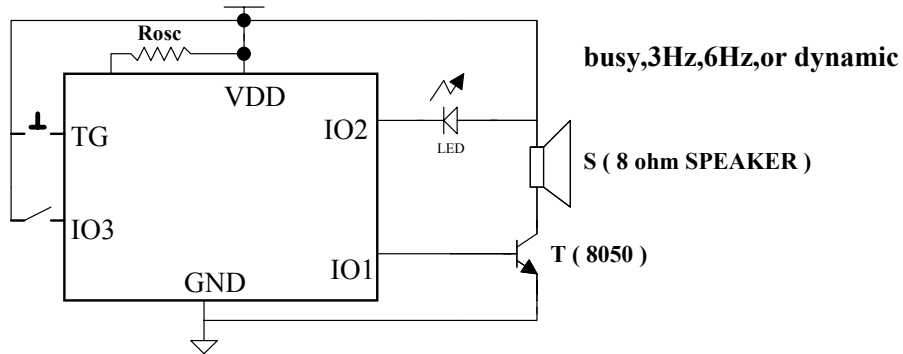

**B> IO1 -- LED ; IO2,IO3 --8,32,64 ohm SPEAKER OR BUZZER.**

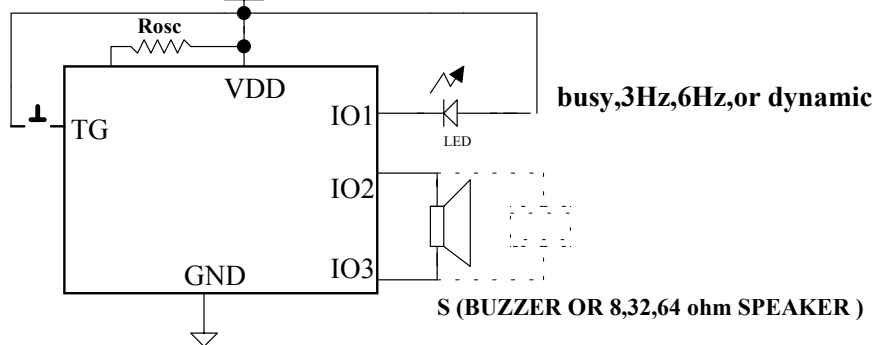

**C> IO1 -- COUT ; IO2,IO3 -- 8,32,64 ohm SPEAKER OR BUZZER.**

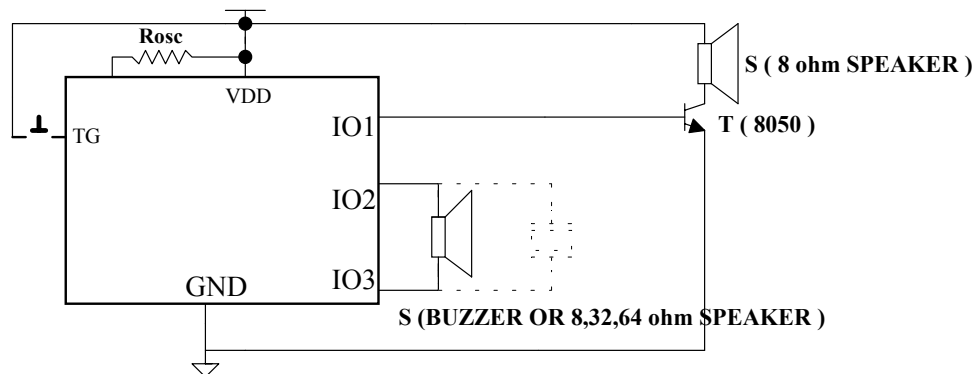

**NOTE:** 1>Rosc=300K ohm ( Rosc=180K ohm in AMA140A ) ( typical ) , or use internal Rosc ( it must be determined before operation )  
 T<sub>bata</sub>=130( typical )  
 2>BUZZER:resonant frequency should around 1KHz.  
 3>Input switch could be replace by CDS.  
 4>COUT,PWM1,PWM2 are tristate during standby.

**APPLICATION CIRCUITS :**

**D > SNOOZE FUNCTION**

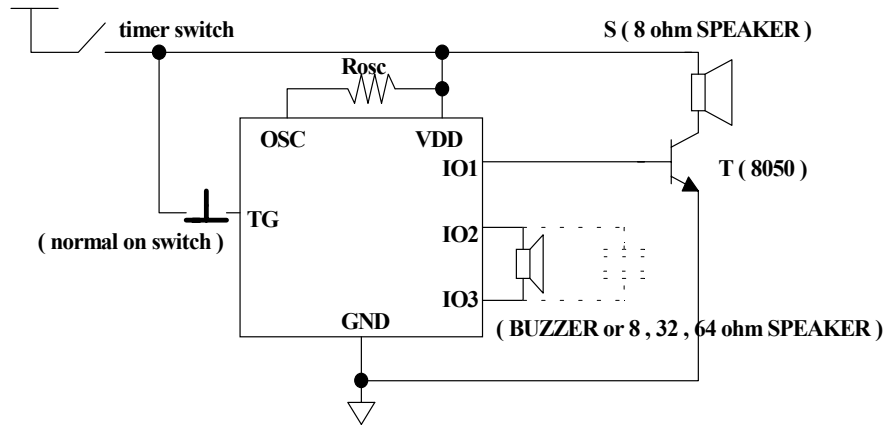

**BONDING DIAGRAM :**

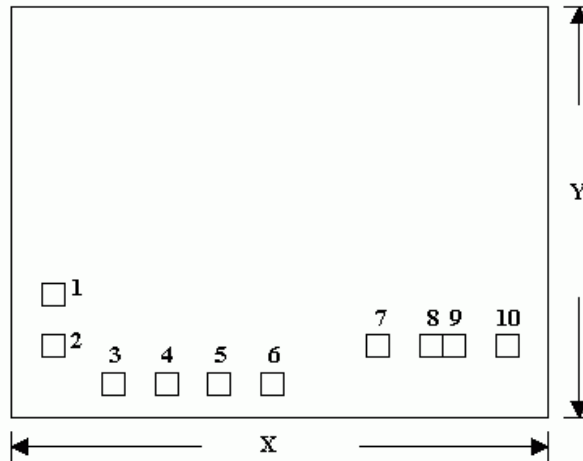



● **DIE SIZE:**

PRODUCT	X	Y	PAD Size (um <sup>2</sup> )	Substrate	UNIT
AVH316B	1450	1080	80 * 80	GND	um
AVH316C AVH316D	1470	1100	80 * 80	GND	um
AV0716C	1450	1230	80 * 80	GND	um
AV0716D	1470	1250	80 * 80	GND	um
AV1416D	1470	1610	80 * 80	GND	um
AV2116A	1470	1970	80 * 80	GND	um
AV2816A	1470	2370	80 * 80	GND	um

PIN NO.	NAME	AVH316B AVH316C AVH316D		AV0716C AV0716D		AV1416D		AV2116A	
		X	Y	X	Y	X	Y	X	Y
1	VDD1	-606.1	-197.4	-606.1	-278	-606.1	-455.2	-606.1	-637.5
2	OSC	-606.1	-378.9	-606.1	459.5	-606.1	-636.7	-606.1	-819.1
3	TEST	-485.2	-378.9	-485.2	459.5	-485.2	-636.7	-485.2	-819.1
4	TG	-364.3	-378.9	-364.3	459.5	-364.3	-636.7	-364.3	-819.1
5	IO1	-243.4	-378.9	-243.4	459.5	-243.4	-636.7	-243.4	-819.1
6	VDD	-116.8	-378.9	-116.8	459.5	-116.8	-636.7	-116.8	-819.1
7	IO2	43.8	-354.3	43.8	434.8	43.8	-612.1	43.8	-794.4
8	GND	274	-374.2	274	454.8	274	-631.9	274	-814.3
9	GND1	354.6	-374.2	354.6	454.8	354.6	-631.9	354.6	-814.3
10	IO3	574.9	-354.3	574.9	434.8	574.9	-612.1	574.9	-794.4

PIN NO.	NAME	AV2816A							
		X	Y						
1	VDD1	-606.1	-823.9						
2	OSC	-606.1	-1005.5						
3	TEST	-485.2	-1005.5						
4	TG	-364.3	-1005.5						
5	IO1	-243.4	-1005.5						
6	VDD	-116.8	-1005.5						
7	IO2	43.8	-975.4						
8	GND	274	-995.3						
9	GND1	354.6	-995.3						
10	IO3	574.9	-975.4						

- **NOTE :** ( 1 ) . All data and specifications are subject to change without notice .
- ( 2 ) . Both VDD and VDD1 be connected to positive power supply ; GND and GND1 be connected to negative power supply for avoid power supply noise during operation .
- ( 3 ) . 0.1 uf capacitor be connected between positive and negative power supply were subjected for operating stability .