

SEMICONDUCTOR

TECHNICAL DATA

225 mW SOT-23

Zener Voltage Regulator Diodes

GENERAL DATA APPLICABLE TO ALL SERIES IN THIS GROUP

Zener Voltage

Regulator Diodes

MAXIMUM CASE TEMPERATURE FOR SOLDERING

PURPOSES: 260°C for 10 seconds

**MMBZ5221BLT1
SERIES
225mW
SOT-23**

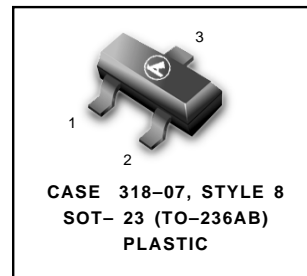
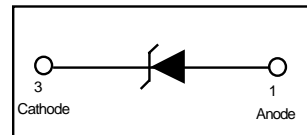

THERMAL CHARACTERISTICS

Characteristic	Symbol	Max	Unit
Total Device Dissipation FR-5 Board* T _A = 25°C	P _D	225	mW
Derate above 25°C		1.8	mW/°C
Thermal Resistance Junction to Ambient	R _{θJA}	556	°C/W
Total Device Dissipation Alumina Substrate,** T _A = 25°C	P _D	300	mW
Derate above 25°C		2.4	mW/°C
Thermal Resistance Junction to Ambient	R _{θJA}	417	°C/W
Junction and Storage Temperature	T _J , T _{stg}	150	°C

**FR-5 = 1.0 x 0.75 x 0.62 in.

**Alumina = 0.4 x 0.3 x 0.024 in. 99.5% alumina.

GENERAL DATA - 225 mW SOT-23

ELECTRICAL CHARACTERISTICS

(Pinout: 1-Anode, 2-NC, 3-Cathode) ($V_F = 0.9\text{ V Max @ } I_F = 10\text{ mA}$ for all types.)

Device	Marking	Test Current I_{ZT} mA	Zener Voltage VZ(+5%) Nominal (Note1)	Z_{Zk} $I_z=0.25\text{mA}$ ΩMax	Z_{Zk} $I_z=I_{ZT}@10\%\text{Mod}$ ΩMax	Max I_R μA	@ V_R V
MMBZ5221BLT1	18A	20	2.4	1200	30	100	1
MMBZ5222BLT1	18B	20	2.5	1250	30	100	1
MMBZ5223BLT1	18C	20	2.7	1300	30	75	1
MMBZ5224BLT1	18D	20	2.8	1400	30	75	1
MMBZ5225BLT1	18E	20	3	1600	29	50	1
MMBZ5226BLT1	8A	20	3.3	1600	28	25	1
MMBZ5227BLT1	8B	20	3.6	1700	24	15	1
MMBZ5228BLT1	8C	20	3.9	1900	23	10	1
MMBZ5229BLT1	8D	20	4.3	2000	22	5	1
MMBZ5230BLT1	8E	20	4.7	1900	19	5	2
MMBZ5231BLT1	8F	20	5.1	1600	17	5	2
MMBZ5232BLT1	8G	20	5.6	1600	11	5	3
MMBZ5233BLT1	8H	20	6	1600	7	5	3.5
MMBZ5234BLT1	8J	20	6.2	1000	7	5	4
MMBZ5235BLT1	8K	20	6.8	750	5	3	5
MMBZ5236BLT1	8L	20	7.5	500	6	3	6
MMBZ5237BLT1	8M	20	8.2	500	8	3	6.5
MMBZ5238BLT1	8N	20	8.7	600	8	3	6.5
MMBZ5239BLT1	8P	20	9.1	600	10	3	7
MMBZ5240BLT1	8Q	20	10	600	17	3	8
MMBZ5241BLT1	8R	20	11	600	22	2	8.4
MMBZ5242BLT1	8S	20	12	600	30	1	9.1
MMBZ5243BLT1	8T	9.5	13	600	13	0.5	9.9
MMBZ5244BLT1	8U	9	14	600	15	0.1	10
MMBZ5245BLT1	8V	8.5	15	600	16	0.1	11
MMBZ5246BLT1	8W	7.8	16	600	17	0.1	12
MMBZ5247BLT1	8X	7.4	17	600	19	0.1	13
MMBZ5248BLT1	8Y	7	18	600	21	0.1	14
MMBZ5249BLT1	8Z	6.6	19	600	23	0.1	14
MMBZ5250BLT1	81A	6.2	20	600	25	0.1	15
MMBZ5251BLT1	81B	5.6	22	600	29	0.1	17
MMBZ5252BLT1	81C	5.2	24	600	33	0.1	18
MMBZ5253BLT1	81D	5	25	600	35	0.1	19
MMBZ5254BLT1	81E	4.6	27	600	41	0.1	21
MMBZ5255BLT1	81F	4.5	28	600	44	0.1	21
MMBZ5256BLT1	81G	4.2	30	600	49	0.1	23
MMBZ5257BLT1	81H	3.8	33	700	58	0.1	25
MMBZ5258BLT1	81J	3.4	36	700	70	0.1	27
MMBZ5259BLT1	81K	3.2	39	800	80	0.1	30
MMBZ5260BLT1	18F	3	43	900	93	0.1	33
MMBZ5261BLT1	81M	2.7	47	1000	105	0.1	36
MMBZ5262BLT1	81N	2.5	51	1100	125	0.1	39
MMBZ5263BLT1	81P	2.2	56	1300	150	0.1	43
MMBZ5264BLT1	81Q	2.1	60	1400	170	0.1	46
MMBZ5265BLT1	81R	2	62	1400	185	0.1	47
MMBZ5266BLT1	81S	1.8	68	1600	230	0.1	52
MMBZ5267BLT1	81T	1.7	75	1700	270	0.1	56
MMBZ5268BLT1	81U	1.5	82	2000	330	0.1	62
MMBZ5269BLT1	81V	1.4	87	2200	370	0.1	68
MMBZ5270BLT1	81W	1.4	91	2300	400	0.1	69

NOTE 1. Zener voltage is measured with a pulse test current (I_{ZT}) applied at an ambient temperature of 25 °C

GENERAL DATA — 225mW SOT-23

TYPICAL CHARACTERISTICS

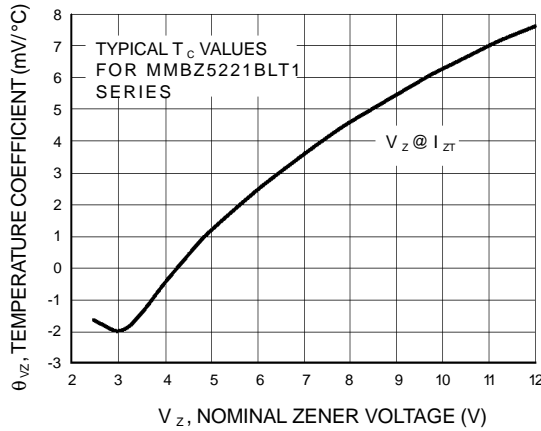

Figure 1. Temperature Coefficients
(Temperature Range -55°C to +150°C)

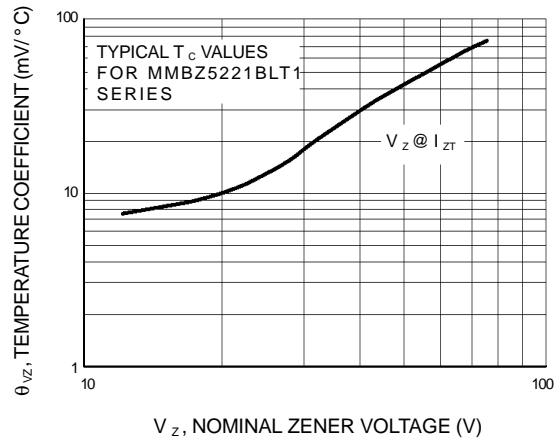

Figure 2. Temperature Coefficients
(Temperature Range -55°C to +150°C)

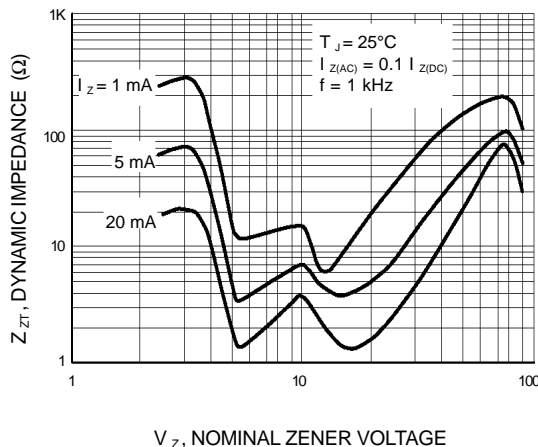

Figure 3. Effect of Zener Voltage on Zener Impedance

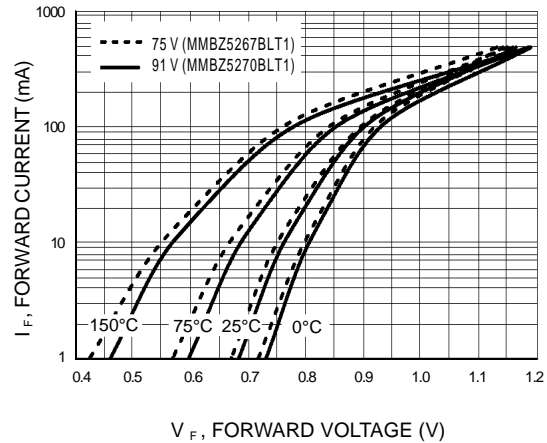

Figure 4. Typical Forward Voltage

GENERAL DATA — 225mW SOT-23

TYPICAL CHARACTERISTICS

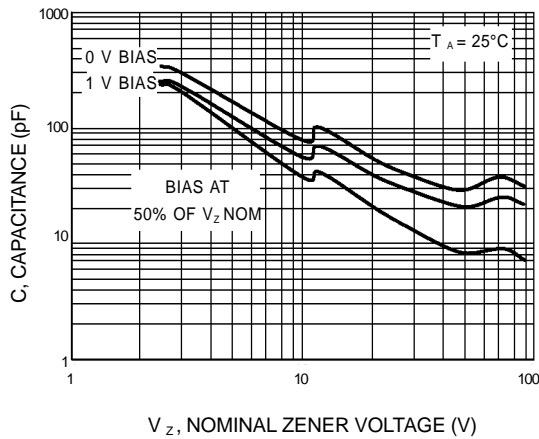

Figure 5. Typical Capacitance

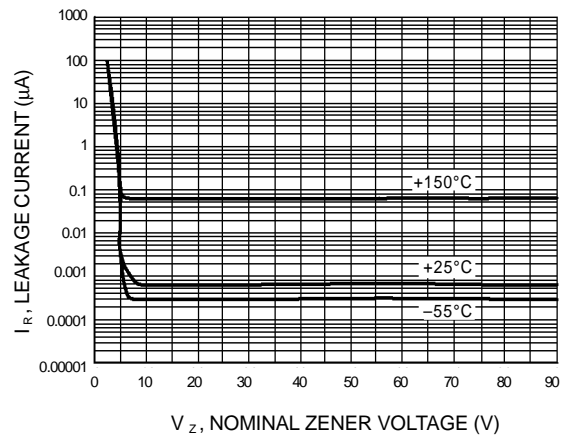

Figure 6. Typical Leakage Current

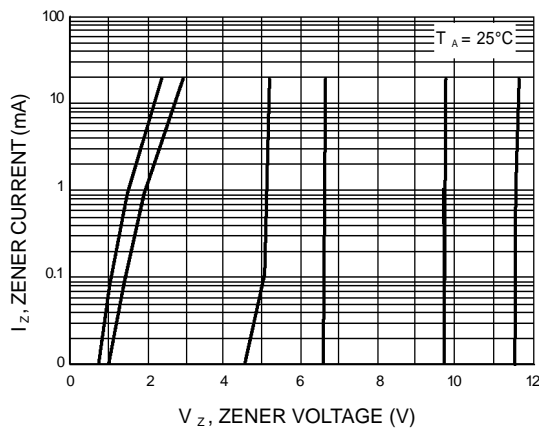

Figure 7. Zener Voltage versus Zener Current (V_z Up to 12 V)

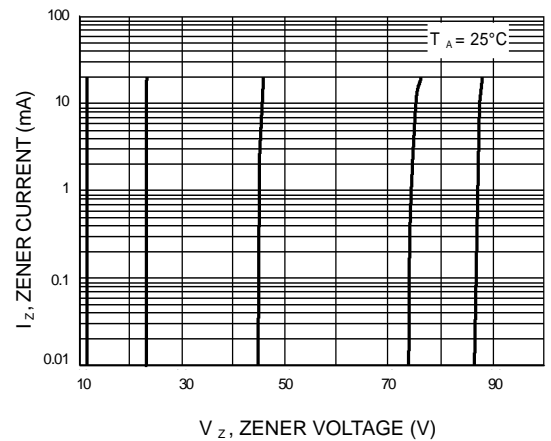

Figure 8. Zener Voltage versus Zener Current (12 V to 91 V)

GENERAL DATA — 225 mW SOT-23

Zener Voltage Regulator Diodes — Surface Mounted

225 mW SOT-23

NOTES:
 1. DIMENSIONING AND TOLERANCING PER ANSI Y14.5M, 1982.
 2. CONTROLLING DIMENSION: INCH.
 3. MAXIMUM LEAD THICKNESS INCLUDES LEAD FINISH THICKNESS. MINIMUM LEAD THICKNESS IS THE MINIMUM THICKNESS OF BASE MATERIAL.

DIM	INCHES		MILLIMETERS	
	MIN	MAX	MIN	MAX
A	0.1102	0.1197	2.80	3.04
B	0.0472	0.0551	1.20	1.40
C	0.0350	0.0440	0.89	1.11
D	0.0150	0.0200	0.37	0.50
G	0.0701	0.0807	1.78	2.04
H	0.0005	0.0040	0.013	0.100
J	0.0034	0.0070	0.085	0.177
K	0.0180	0.0236	0.45	0.60
L	0.0350	0.0401	0.89	1.02
S	0.0830	0.0984	2.10	2.50
V	0.0177	0.0236	0.45	0.60

STYLE 8:
 PIN 1. ANODE
 2. NO CONNECTION
 3. CATHODE

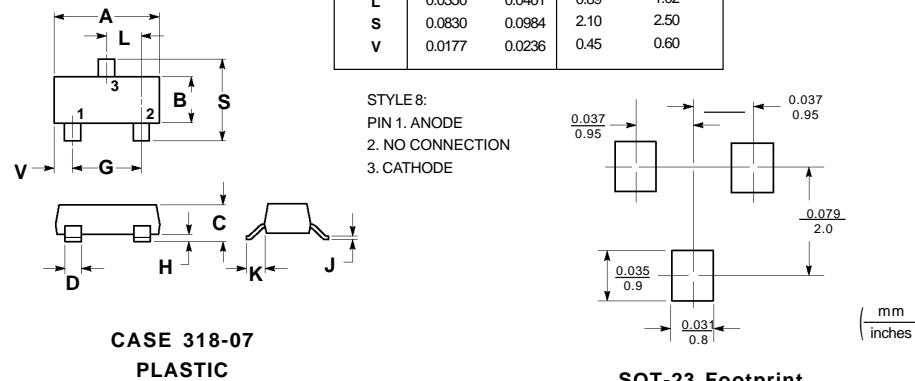

CASE 318-07
 PLASTIC

SOT-23 Footprint

(mm / inches)

(Refer to Section 10 for Surface Mount, Thermal Data and Footprint Information.)

MULTIPLE PACKAGE QUANTITY (MPQ) REQUIREMENTS

Package Option	Type No. Suffix	MPQ (Units)
Tape and Reel	T1	3K
Tape and Ammo	T3	10K

(Refer to Section 10 for more information on Packaging Specifications.)