

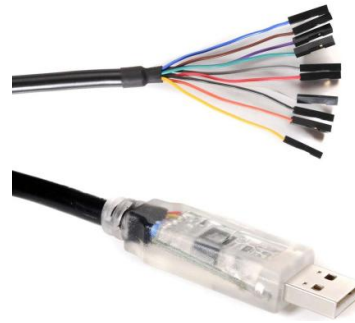

FTDI
Chip



Future Technology Devices International Ltd

C232HM

USB 2.0 Hi-Speed to MPSSE Cable

Datasheet

Document Reference No.: FT_000401

Version 1.0

Issue Date: 2011-07-21

Future Technology Devices International Limited (FTDI)

Unit 1, 2 Seaward Place, Glasgow G41 1HH, United Kingdom

Tel.: +44 (0) 141 429 2777 Fax: + 44 (0) 141 429 2758

E-Mail (Support): support1@ftdichip.com Web: <http://www.ftdichip.com>

Use of FTDI devices in life support and/or safety applications is entirely at the user's risk, and the user agrees to defend, indemnify and hold harmless FTDI from any and all damages, claims, suits or expense resulting from such use.

© Copyright 2011 Future Technology Devices International Ltd

1 Description

The **USB 2.0 Hi-Speed to MPSSE cable** contains a small internal electronic circuit board, utilising the FTDI FT232H, which is encapsulated into the USB connector end of the cable, this handles all the USB signalling and protocols. The cable provides a fast, simple way to connect devices with 3.3 Volt digital interfaces to USB. For full details of the IC, consult the FT232H datasheet, this is available from [DS_FT232H](#).

The integrated FT232H device incorporates a command processor called the Multi-Protocol Synchronous Serial Engine (MPSSE). The purpose of the MPSSE command processor is to communicate with devices which use synchronous protocols (such as JTAG, SPI or I²C) in an efficient manner. Full details are available in the [MPSSE application note - AN_108](#).

The cable is terminated by ten individual wires with single pole connectors which can be interfaced to a male header. Cable signals are compliant with CMOS logic at 3.3 volts.

The FT232H is a single channel USB 2.0 Hi-Speed (480Mb/s) to UART/FIFO IC. It can be configured in a variety of industry standard serial or parallel interfaces, such as MPSSE - JTAG, SPI, I²C.

The C232HM MPSSE cable is easily configured into each interface e.g. JTAG, SPI, I²C via the application software.

The cable is powered from a USB host port and is USB 2.0 Hi-Speed compatible. The cable is 0.5m long and supports a data transfer up to 30Mbps in MPSSE mode.

The C232HM MPSSE cable requires USB device drivers, available free from <http://www.ftdichip.com>. The D2XX driver is used with application software to directly access the FT232H in the cable through a DLL. This is illustrated in the Figure 1-1

The C232HM MPSSE cable uses the FTDI's FT232H USB to serial IC device.

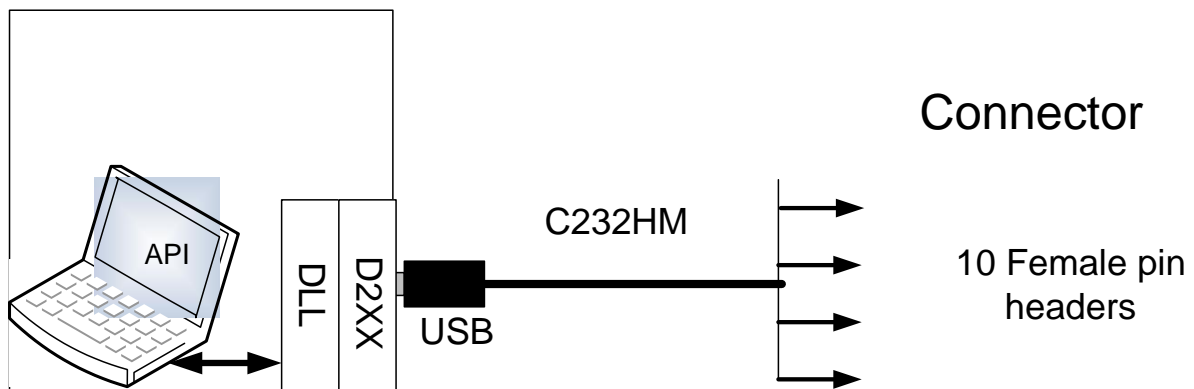

Software application access to USB via D2XX

Figure 1-1 Using the C232HM MPSSE Cable

1.1 Available Cables and Part Numbers

The following Table 1.1 gives details of the available C232HM MPSSE cables.

Part Number	Description	End Connector	Cable details
C232HM-DDHSL-0	USB to MPSSE cable with +3.3V digital level signals. Maximum output of 200mA @ 3.3VDC on VCC (see Note 1)	Single pole, receptacle x 10	10 core, UL2464 24 AWG, diam=6.5mm
C232HM-EDHSL-0	USB to MPSSE cable with +3.3V digital level signals. Maximum output of 200mA @ 5.0VDC on VCC (see Note 2)	Single pole, receptacle x 10	10 core, UL2464 24 AWG, diam=6.5mm

Table 1.1 C232HM MPSSE Cable Descriptions and Part Numbers

Note 1: The VCC power output signal (RED wire) is 3.3V. The source of 3.3V is the onboard regulator output, which is switched onto the power output signal.

Note 2: The VCC power output signal (RED wire) is 5.0V. The source of 5.0V is the USB VBUS input, which is switched onto the power output signal.

FTDI supports customised end connector designs. For more information, please contact your local FTDI sales office (see end of datasheet for contact details).

1.2 Certifications

The FTDI C232HM MPSSE cables are fully RoHS, FCC and CE compliant.

Table of Contents

1	Description	1
1.1	Available Cables and Part Numbers.....	2
1.2	Certifications.....	2
2	Typical Applications.....	4
2.1	Driver Support	4
2.2	Features.....	5
3	C232HM MPSSE Cable connection and Mechanical Details	6
3.1	C232HM MPSSE Cable Signal Descriptions	7
3.2	C232HM MPSSE Cable Signal Descriptions	8
3.3	C232HM MPSSE Cable Electrical Parameters	9
3.3.1	C232HM-DDHSL-0 Electrical Parameters.....	9
3.3.2	C232HM-EDHSL-0 Electrical Parameters	9
3.3.1	C232HM-DDHSL-0 and C232HM-EDHSL-0 I/O Characteristics	10
4	Cable PCB Circuit Schematic.....	11
5	Contact Information	13
	Appendix A - Cable EEPROM Configuration.....	15
	Appendix B - List of Figures and Tables	16
	Appendix C – Revision History	17

2 Typical Applications

- USB to JTAG interfaces
- USB to SPI interfaces
- USB to I²C interfaces
- Interfacing MCU / PLD / FPGA based designs to USB
- USB Audio and Low Bandwidth Video data transfer
- Rapid USB integration into existing electronic systems
- Prototyping platform for USB interface on new systems
- USB Instrumentation

2.1 Driver Support

Royalty free D2XX *Direct Drivers*

(USB Drivers + DLL S/W Interface)

- Windows 98, 98SE, ME, 2000, Server 2003, XP and Server 2008
- Windows XP and XP 64-bit
- Windows 7 and Windows 7 64-bit
- Windows Vista and Vista 64-bit
- Windows CE 4.2, 5.0 and 6.0
- Linux 2.4.20 and greater

The drivers listed above are all available to download for free from <http://www.ftdichip.com>. Various Third-Party Drivers are also available for various other operating systems - see <http://www.ftdichip.com/Support/Links.htm> for details.

2.2 Features

- Based on the Single chip USB Hi-Speed FT232H device
- USB 2.0 Hi-Speed (480Mbps/Second) and Full Speed (12Mbps/Second) compatible
- Entire USB protocol handled on the chip – No USB-specific firmware programming required
- USB Type A connector for direct connection to a host or hub
- USB bus powered
- Fully assisted hardware or X-On / X-Off software handshaking
- Synchronous Serial (MPSSE) data rates of up to 30Mbps on JTAG, SPI and I2C
- 1kByte receive and transmit buffers for high data throughput
- Transmit and receive LED drive signals
- Adjustable receive buffer timeout
- Support for USB suspend and resume
- Low operating and USB suspend current
- Low USB bandwidth consumption
- UHCI / OHCI / EHCI host controller compatible
- -40°C to +85°C operating temperature range
- Cable length is 0.5m (19.7 inch)
- Custom versions also available (subject to Minimum Order Quantity (MOQ))
- FTDI's royalty-free D2XX drivers eliminate the requirement for USB driver development in most cases

3 C232HM MPSSE Cable connection and Mechanical Details

The following Figure 3-1 shows the cable signals and the wire colours for these signals on the C232HM MPSSE cable.

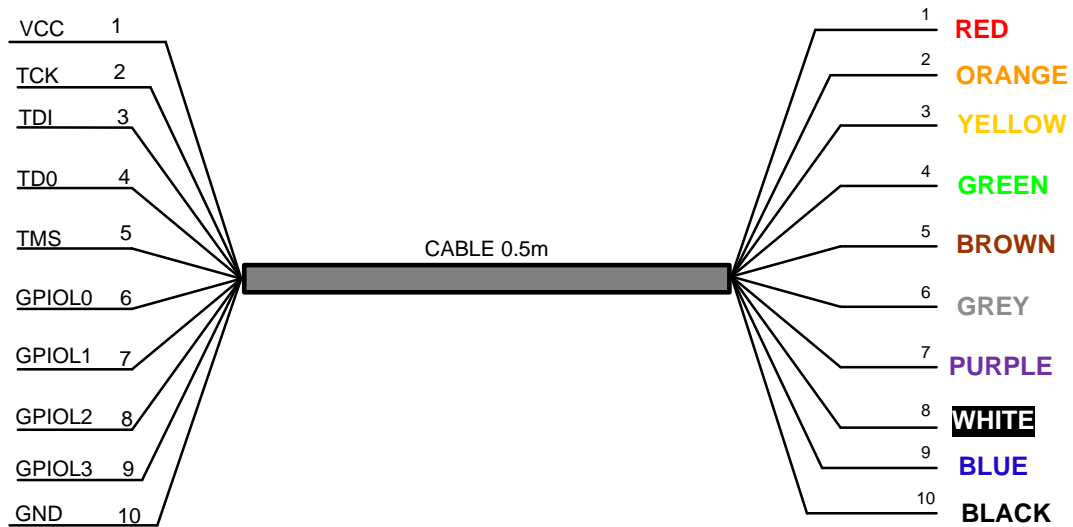

Figure 3-1 C232HM MPSSE Cable Connections (numbers refer to pad numbers on the PCB)

3.1 C232HM MPSSE Cable Signal Descriptions

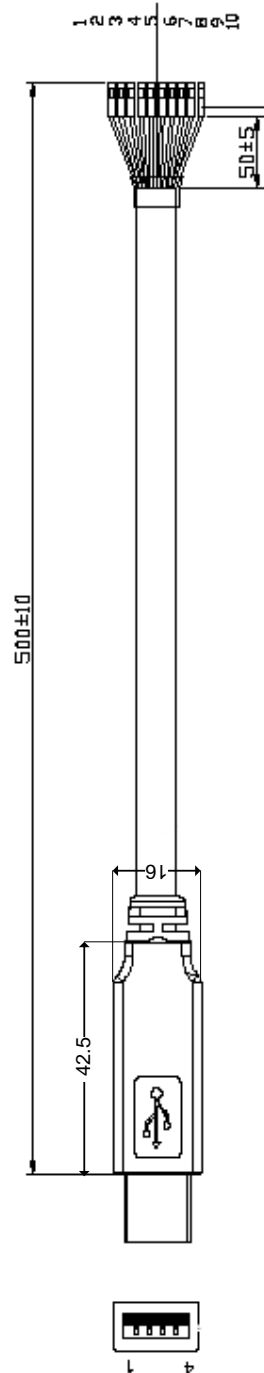

Figure 3-2 C232HM MPSSE Cable Mechanical Details (dimensions in mm)

3.2 C232HM MPSSE Cable Signal Descriptions

Colour	Pin Number	Name	Type	Description
Red	1	VCC	Output	Power Supply Output to target board.
Gray	6	GPIOL0	Input/Output	General Purpose input/output.
Purple	7	GPIOL1	Input/Output	General Purpose input/output.
White	8	GPIOL2	Input/Output	General Purpose input/output.
Blue	9	GPIOL3	Input/Output	General Purpose input/output.
Black	10	GND	GND	Device ground supply pin.

Table 3.1 Common Cable Signal Descriptions

Colour	Pin Number	Name	Type	Description
Orange	2	TCK	Output	Test Interface Clock
Yellow	3	TDI	Input	Test Data Input
Green	4	TDO	Output	Test Data Output
Brown	5	TMS	Output	Test Mode Select

Table 3.2 MPSSE Option JTAG - Signal Descriptions

Colour	Pin Number	Name	Type	Description
Orange	2	SK	Output	Serial Clock
Yellow	3	DO	Output	Serial data output
Green	4	DI	Input	Serial Data Input
Brown	5	CS	Output	Serial Chip Select

Table 3.3 MPSSE Option SPI - Signal Descriptions

Colour	Pin Number	Name	Type	Description
Orange	2	SCL	Output	Serial Clock
Yellow	3	SDA	Input/Output	Serial data signal shorted together to create bidirectional data(both yellow and green wires need to be shorted together)
Green	4			

Table 3.4 MPSSE Option I2C - Signal Descriptions

3.3 C232HM MPSSE Cable Electrical Parameters

3.3.1 C232HM-DDHSL-0 Electrical Parameters

Parameter	Description	Minimum	Typical	Maximum	Units	Conditions
VCC	Output Power Voltage	3.2	3.3	3.6	V	
I _o	Output Power Current	-	-	200	mA	
T	Operating Temperature Range	-40		+85	°C	

Table 3.5 C232HM-DDHSL-0 Operating Parameters

3.3.2 C232HM-EDHSL-0 Electrical Parameters

Parameter	Description	Minimum	Typical	Maximum	Units	Conditions
VCC	Output Power Voltage	4.75	5	5.25	V	
I _o	Supply Current	-	-	200	mA	Must be less than 2.5mA during suspend.
T	Operating Temperature Range	-40		+85	°C	

Table 3.6 C232HM-EDHSL-0 Power Supply Output Parameters

3.3.1 C232HM-DDHSL-0 and C232HM-EDHSL-0 I/O Characteristics

Parameter	Description	Minimum	Typical	Maximum	Units	Conditions
Voh	Output Voltage High	2.40	3.14		V	Ioh = +/-2mA I/O Drive strength* = 4mA
			3.20		V	I/O Drive strength* = 8mA
			3.22		V	I/O Drive strength* = 12mA
			3.22		V	I/O Drive strength* = 16mA
Vol	Output Voltage Low		0.18	0.40	V	Iol = +/-2mA I/O Drive strength* = 4mA
			0.12		V	I/O Drive strength* = 8mA
			0.08		V	I/O Drive strength* = 12mA
			0.07		V	I/O Drive strength* = 16mA
Vil	Input low Switching Threshold		-	0.80	V	LVTTL
Vih	Input High Switching Threshold	2.00	-		V	LVTTL
Vt	Switching Threshold		1.50		V	LVTTL
Vt-	Schmitt trigger negative going threshold voltage	0.80	1.10	-	V	
Vt+	Schmitt trigger positive going threshold voltage		1.60	2.00	V	
Rpu	Input pull-up resistance	40	75	190	KΩ	Vin = 0
Rpd	Input pull-down resistance	40	75	190	KΩ	Vin =VCCIO
Iin	Input Leakage Current	15	45	85	μA	Vin = 0
Ioz	Tri-state output leakage current		±10		μA	Vin = 5.5V or 0

Table 3.7 C232HD-DDHSP-0 and C232HD-EDHSP-0 I/O Pin Characteristics

* The I/O drive strength and slow slew-rate are configurable in the EEPROM.

The I/O pins are +3.3v cells, which are +5V tolerant

4 Cable PCB Circuit Schematic

The circuit schematics for the small internal electronic circuit board, utilising the FTDI FT232H, which is encapsulated into the USB connector end of the cable, are shown in Figure 4.1 Circuit Schematic of C232HM-DDHSL-0 and Figure 4.2 - Circuit Schematic of PCB - C232HM-EDHSL-0.

Customised versions of these cables are also available. Users interested in customised versions of these cables should contact FTDI sales (sales1@ftdichip.com).

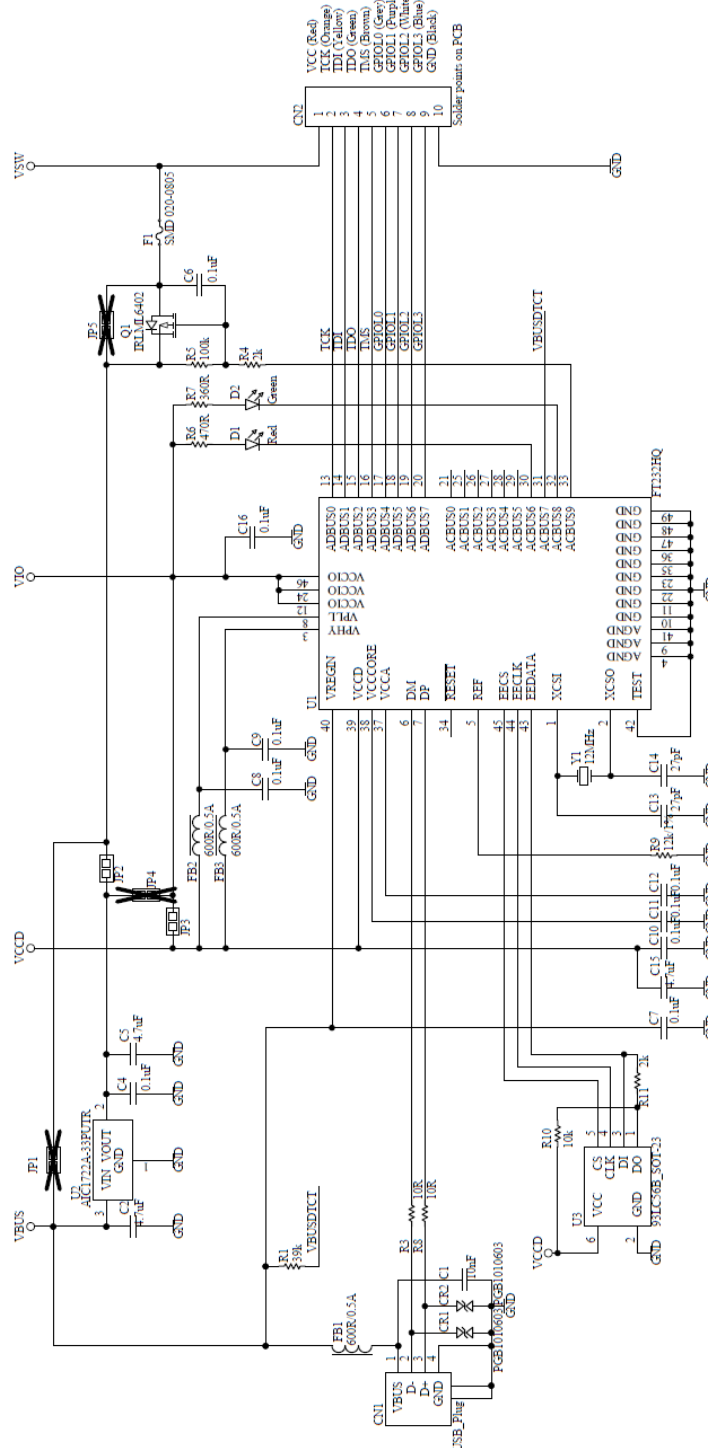

Figure 4.1 Circuit Schematic of C232HM-DDHSL-0

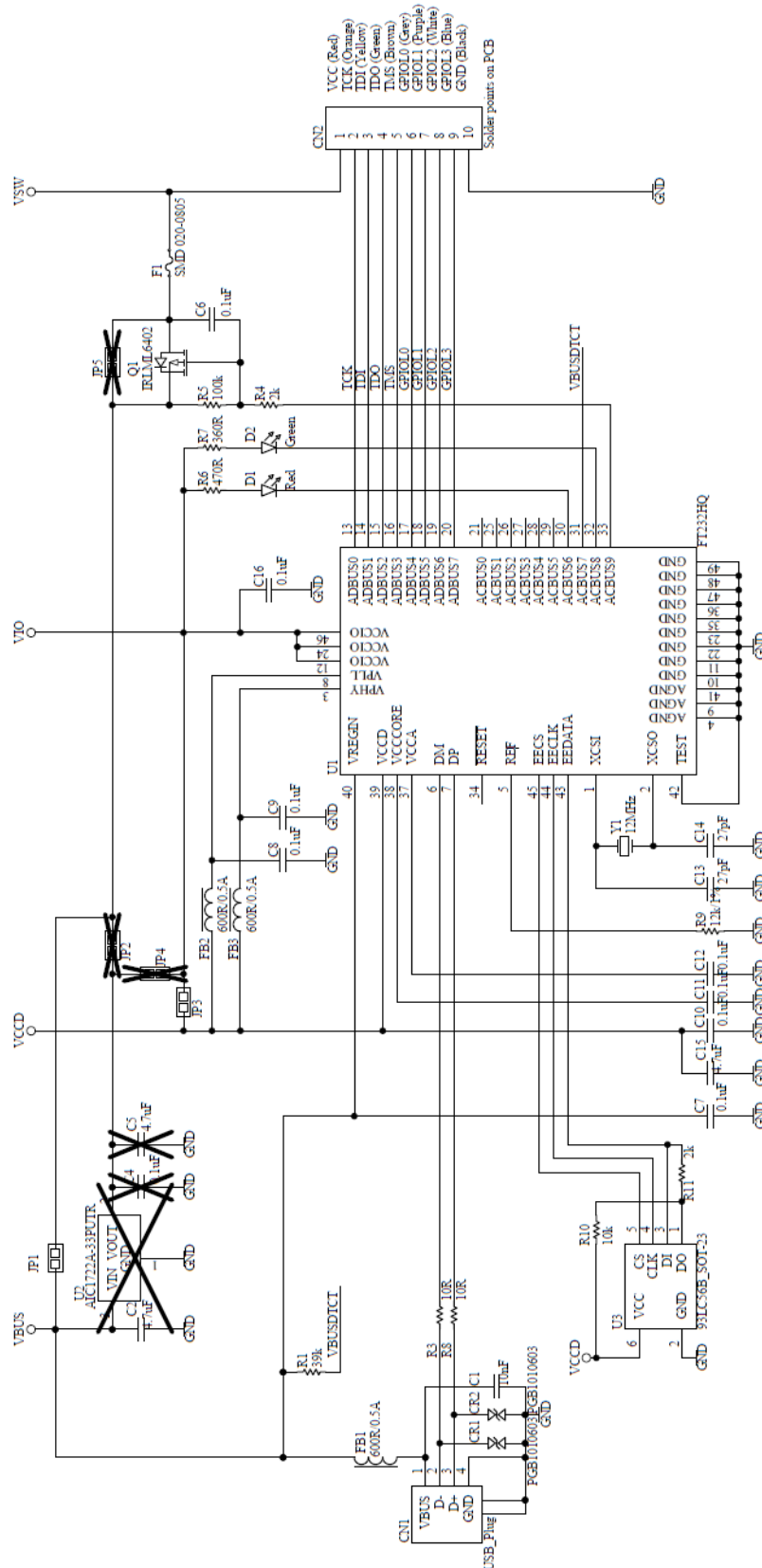

Figure 4.2 - Circuit Schematic of PCB - C232HM-EDHSL-0

5 Contact Information

Head Office – Glasgow, UK

Future Technology Devices International Limited
Unit 1, 2 Seaward Place,
Centurion Business Park
Glasgow, G41 1HH
United Kingdom
Tel: +44 (0) 141 429 2777
Fax: +44 (0) 141 429 2758

E-mail (Sales) sales1@ftdichip.com
E-mail (Support) support1@ftdichip.com
E-mail (General Enquiries) admin1@ftdichip.com
Web Site URL <http://www.ftdichip.com>
Web Shop URL <http://www.ftdichip.com>

Branch Office – Taipei, Taiwan

Future Technology Devices International Limited (Taiwan)
2F, No. 516, Sec. 1, NeiHu Road
Taipei 114
Taiwan, R.O.C.
Tel: +886 (0) 2 8797 1330
Fax: +886 (0) 2 8751 9737

E-mail (Sales) tw.sales1@ftdichip.com
E-mail (Support) tw.support1@ftdichip.com
E-mail (General Enquiries) tw.admin1@ftdichip.com
Web Site URL <http://www.ftdichip.com>

Branch Office – Hillsboro, Oregon, USA

Future Technology Devices International Limited (USA)
7235 NW Evergreen Parkway, Suite 600
Hillsboro, OR 97123-5803
USA
Tel: +1 (503) 547 0988
Fax: +1 (503) 547 0987

E-Mail (Sales) us.sales@ftdichip.com
E-mail (Support) us.support@ftdichip.com
E-mail (General Enquiries) us.admin@ftdichip.com
Web Site URL <http://www.ftdichip.com>

Branch Office – ShangHai, China

Future Technology Devices International Limited (China)
Room 408, 317 Xianxia Road,
ChangNing District,
ShangHai, P.R. China

Tel: +86 (21) 62351596
Fax: +86 (21) 62351595

E-Mail (Sales) cn.sales@ftdichip.com
E-mail (Support) cn.support@ftdichip.com
E-Mail (General Enquiries) cn.admin@ftdichip.com
Web Site URL <http://www.ftdichip.com>

Distributor and Sales Representatives

Please visit the Sales Network page of the FTDI Web site for the contact details of our distributor(s) and sales representative(s) in your country.

System and equipment manufacturers and designers are responsible to ensure that their systems, and any Future Technology Devices International Ltd (FTDI) devices incorporated in their systems, meet all applicable safety, regulatory and system-level performance requirements. All application-related information in this document (including application descriptions, suggested FTDI devices and other materials) is provided for reference only. While FTDI has taken care to assure it is accurate, this information is subject to customer confirmation, and FTDI disclaims all liability for system designs and for any applications assistance provided by FTDI. Use of FTDI devices in life support and/or safety applications is entirely at the user's risk, and the user agrees to defend, indemnify and hold harmless FTDI from any and all damages, claims, suits or expense resulting from such use. This document is subject to change without notice. No freedom to use patents or other intellectual property rights is implied by the publication of this document. Neither the whole nor any part of the information contained in, or the product described in this document, may be adapted or reproduced in any material or electronic form without the prior written consent of the copyright holder. Future Technology Devices International Ltd, Unit 1, 2 Seaward Place, Centurion Business Park, Glasgow G41 1HH, United Kingdom. Scotland Registered Company Number: SC136640.

Appendix A - Cable EEPROM Configuration

Each C232HM MPSSE cable is controlled by the FTDI FT232H IC. This FT232H device contains an EEPROM which contains the USB configuration descriptors for that device. When the cable is plugged into a PC or a USB reset is performed, the PC will read these descriptors. The default values stored into the internal EEPROM are defined in the following table

Parameter	Value	Notes
USB Vendor ID (VID)	0403h	FTDI default VID (hex)
USB Product UD (PID)	6014h	FTDI default PID (hex)
Serial Number Enabled?	Yes	
Serial Number	See Note	A unique serial number is generated and programmed into the EEPROM during device final test.
Manufacturer Name	FTDI	
Product Description	See note	Product description depends on the cable. The following lists a the Product descriptions for each different cable. C232HM-VSW3V3 C232HM-VSW5V0
Max Bus Power Current	500mA	Includes power available from the cable plus power required for the FT232H
Power Source	Bus Powered	
Device Type	FT232H	
USB Version	0200	Returns USB 2.0 device description to the host. Note: The device is a USB 2.0 Hi-Speed device (480Mb/s).
Remote Wake Up	Disabled	500uA suspend limit when in this state
High Current I/Os	Enabled	Enables the high drive level on the CBUS I/O pins.
Invert TXD	Disabled	Signal on this pin becomes TXD# if enable.
Invert RXD	Disabled	Signal on this pin becomes RXD# if enable.
Invert RTS#	Disabled	Signal on this pin becomes RTS if enable.
Invert CTS#	Disabled	Signal on this pin becomes CTS if enable.

Default Internal EEPROM Configuration

The internal EEPROM in the cable can be re-programmed over USB using the utility program FT_PROG. Both can be downloaded from www.ftdichip.com.

Appendix B - List of Figures and Tables

List of Figures

Figure 1-1 Using the C232HM MPSSE Cable	1
Figure 4-1 C232HM MPSSE Cable Connections (numbers refer to pad numbers on the PCB)	6
Figure 4-2 C232HM MPSSE Cable Mechanical Details (dimensions in mm)	7
Figure 5.1 Circuit Schematic of C232HM-DDHSL-0.....	11
Figure 5.2 - Circuit Schematic of PCB - C232HM-EDHSL-0	12

List of Tables

Table 1.1 C232HM MPSSE Cable Descriptions and Part Numbers	2
Table 4.1 Common Cable Signal Descriptions	8
Table 4.2 MPSSE Option JTAG - Signal Descriptions	8
Table 4.3 MPSSE Option SPI - Signal Descriptions.....	8
Table 4.4 MPSSE Option I2C - Signal Descriptions.....	8
Table 4.2 C232HM-DDHSL-0 Operating Parameters.....	9
Table 4.4 C232HM-EDHSL-0 Power Supply Output Parameters.....	9
Table 4.3 C232HD-DDHSP-0 and C232HD-EDHSP-0 I/O Pin Characteristics	10

Appendix C – Revision History

Version 1.0

First Release

21st July 2011