

SD

M55339/19-00565

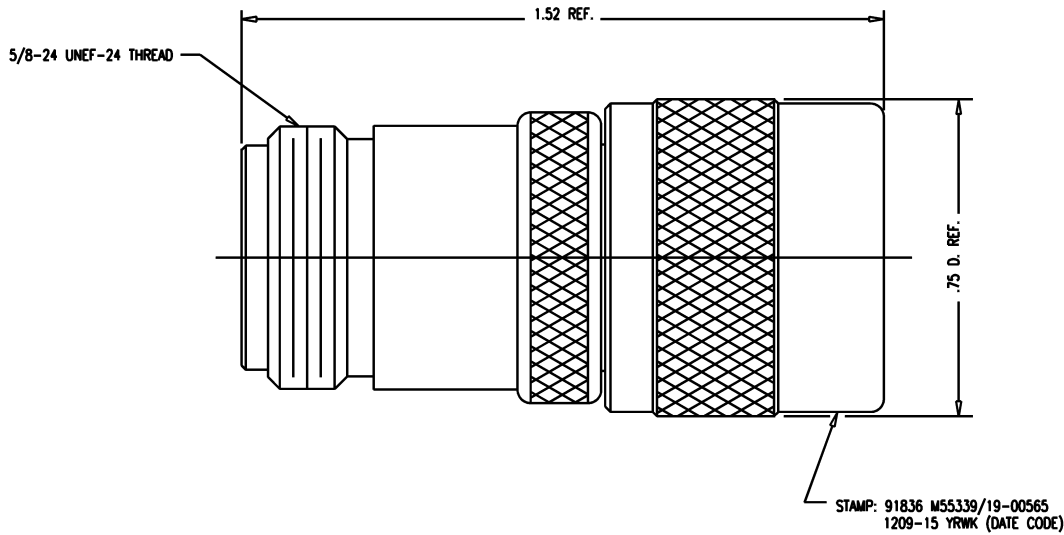

NOTES:

1. N INTERFACE PER MIL-STD-348, FIG. 304-2.
2. C INTERFACE PER MIL-STD-348, FIG. 302-1.
3. MATERIALS:
 - INSULATORS- TEFLON, ASTM-D-4894
 - GASKET- SILICONE RUBBER, ZZ-R-765
 - CENTER CONTACT)
 - OUTER CONTACT) BER. COP., ASTM-B-196
 - SPRING WASHER)
 - C RING- HARD DRAWN COPPER WIRE PER QQ-W-336
 - ALL OTHER PARTS-BRASS, ASTM-B16
4. FINISHES:
 - CENTER CONTACT & C RING-GOLD PLATE PER MIL-G-45204
 - OUTER CONTACT & SPRING WASHER-SILVER PLATE PER QQ-S-365
 - ALL OTHER METAL PARTS-SILVER PLATE PER QQ-S-365
5. ELECTRICAL CHARACTERISTICS:
 - NOMINAL IMPEDANCE-50 OHMS
 - WORKING VOLTAGE-1000 VRMS
 - FREQUENCY RANGE-DC TO 11 GHZ

STAMP: 91836 M55339/19-00565
1209-15 YRWM (DATE CODE)

REVISIONS

ISSUE	CHANGES
1	RESTRICTED USAGE NM 06/30/77
2	RESTRICTION REMOVED ER 18105 NM 03/02/78
3	CN 23170 E MA 03/19/82
4	CN 35618 D ME 01/09/95
5	CN 37594 C REDRAWN TML 02/16/00
6	CN 38329 E TML 06/01/01

1209-15S

SCALE 4:1

APPROX SURFACE AREA

1209-15

USED ON

REF:

ADAPTER N(F)-C(M)

DRAWN JHP DATE 06/10/77

DESIGN DATE

APPR. JC DATE 09/27/77

KINGS

ELECTRONICS CO., INC.
ROCK HILL, SOUTH CAROLINA 29730

M55339/19-00565

SD