

Features

- Compact 2012 (0805) package with super bright AlInGaP die
- Excellent for membrane switch panels and indicators

Applications

- Mobile devices (cellular telephones, PDAs, pagers)
- Audio visual equipment
- Telecommunications

Outline Dimensions

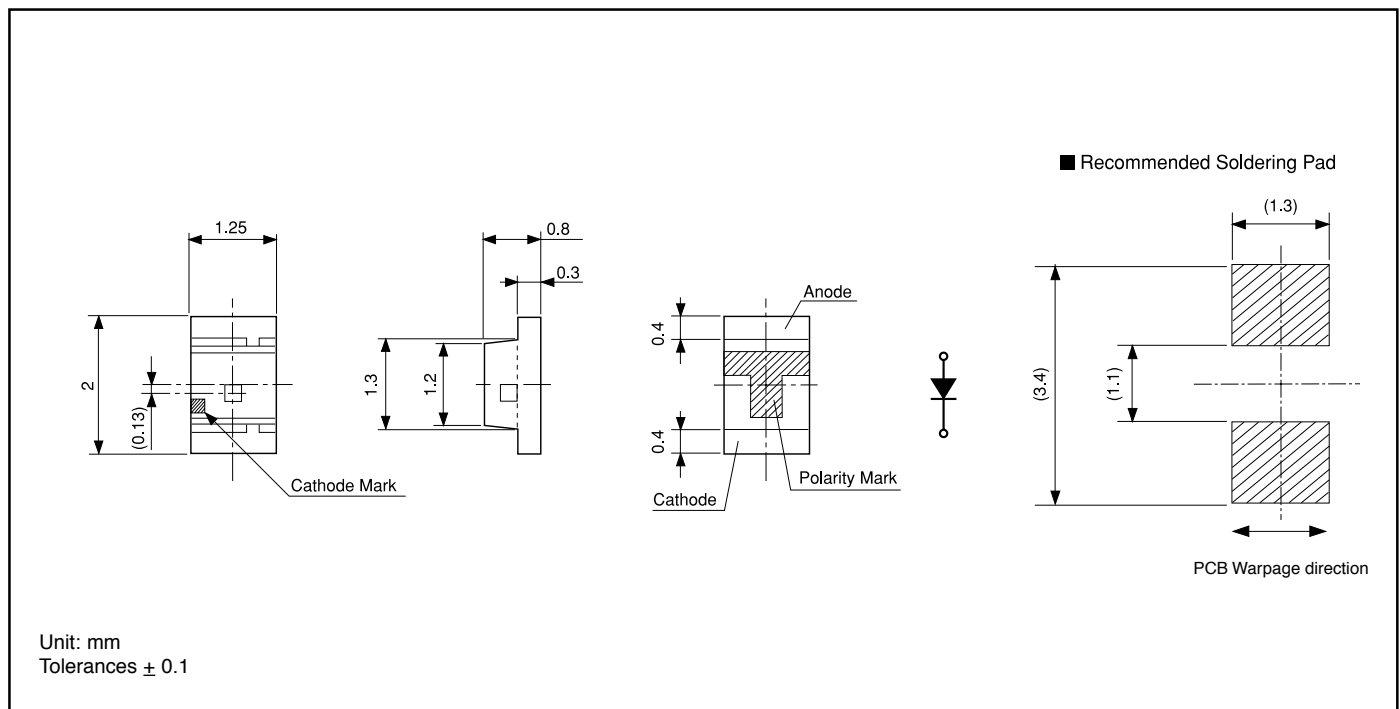

Electro-Optical Characteristics

(Ta=25°C)

Part No.	Material	Emitted Color	Lens Color	Luminous Intensity I_V			Wavelength				Forward Voltage V_F			Reverse Current I_R		Viewing Angle (2θ 1/2)	
				MIN.	TYP.	I_F	Peak λ_p TYP.	Dominant λ_d TYP.	Spectral Line Half Width $\Delta\lambda$ TYP.	I_F	TYP.	MAX.	I_F	MAX.	V_R		
FR1112H	AlInGaP	Red	Milky White	25	50	20	635	626	15	20	1.9	2.4	20	100	5	150°	
FA1112H	AlInGaP	Orange		25	65	20	609	605	15	20	1.9	2.4	20	100	5		
FY1112H	AlInGaP	Yellow		25	65	20	592	590	15	20	1.9	2.4	20	100	5		
Units				mcd	mA		nm			mA		V	mA		μ A	V	Deg.



Absolute Maximum Ratings

(Ta=25°C)

Item	Symbol	Red	Orange	Yellow	Units
		FR	FA	FY	
Power Dissipation	Pd	81	81	81	mW
Forward Current	I _F	30	30	30	mA
Peak Forward Current	I _{FM}	100	100	100	mA
Reverse Voltage	V _R	5	5	5	V
Operating Temperature	Topr	-40 to +85			°C
Storage Temperature	Tstg	-40 to +100			°C
Derating*	ΔI _F	0.43 (DC) 1.0 (Pulse)			mA/°C

* Ta=25°C, I_{FM} applies for the pulse width ≤ 1msec. and duty cycle ≤ 1/20.

Operation Current Derating Chart (DC)

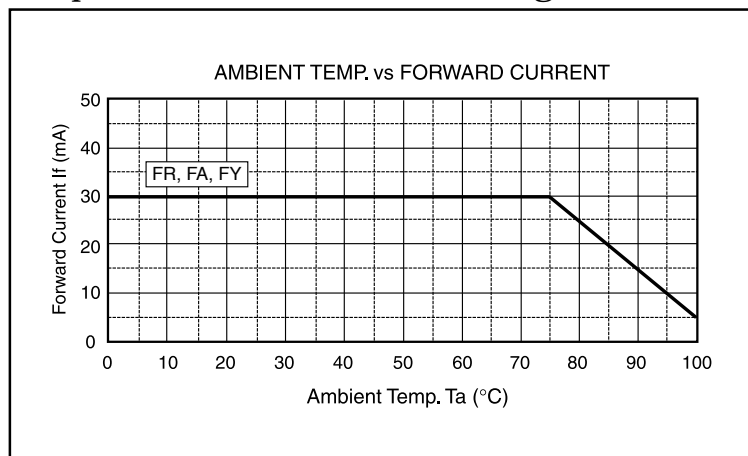

Spatial Distribution

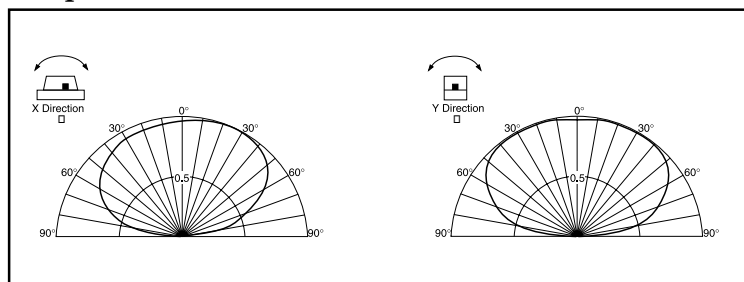

Taping Specifications

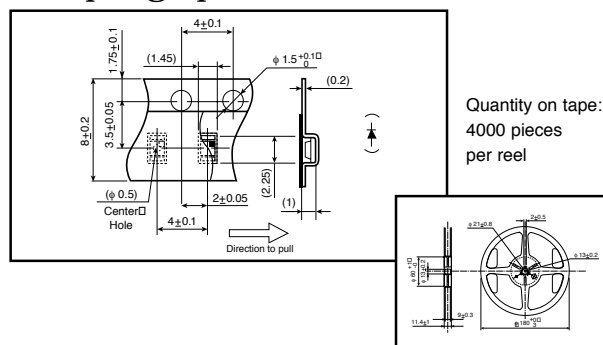

Precautions

Please follow these handling precautions to prevent damage to the chip and ensure its reliability.

1. Soldering conditions:

- **Soldering iron:** Temperature at tip of iron: 280°C max. (30W max.)
Soldering time: 3 sec. max.
- **Dip soldering:** Preheating: 120° ~ 150°C max. (resin surface temp.)
60 ~ 120 sec. max. Bath temperature: 260°C max. Dipping Time: 5 sec. max.
- **Reflow Soldering:**

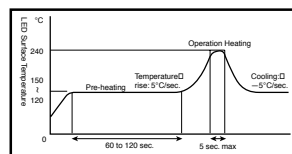

2. Cleaning:

- If cleaning is required, use the following solutions for less than 1 minute, at less than 40°C.
- Appropriate chemicals: Ethyl alcohol and isopropyl alcohol.
- Effect of ultrasonic cleaning on the LED resin body differs depending on such factors as the oscillator output, size of PCB and LED mounting method. The use of ultrasonic cleaning should be enforced at proper output after confirming there is no problem.

Product specifications subject to change without notice. PGF_1112H-0301

Stanley Electric Sales of America, Inc.

2660 Barranca Parkway, Irvine, CA 92606 • Tel: 800-LED-LCD1 (533-5231) • Fax: 949-222-0555

Website: www.stanley-electric.com

