

- Low Power Consumption : 35 μ A (TYP.)
- Maximum Output Current : more than 700mA (800mA limit)
- Dropout Voltage : 50mV @ 100mA
: 100mV @ 200mA
- Operating Voltage Range : 1.5V ~ 6.0V
- VR Output Voltage Range : 0.8V ~ 5.0V
VD Output Voltage Range : 0.8V ~ 5.0V
- Low ESR capacitor compatible

■ GENERAL DESCRIPTION

The XC6402 series are precise, low noise, high current, positive voltage low dropout regulators with built-in voltage detector. They are fabricated using Torex's CMOS process. The series features a voltage reference, an error amplifier, a current limiter, a voltage detector and a phase compensation circuit plus a driver transistor.

The output voltage of the LDO and detect voltage of the detector is selectable in 50mV increments within the range of 0.8V to 5.0V.

With a low ON resistance driver transistor built-in, batteries can be used until input-output voltage differential is minimal and can accordingly be used for a longer time.

The series is also compatible with low ESR ceramic capacitors which give added output stability.

The series provides options to the user to select from a variety of circuit features, such as detector monitoring, detector output logic, EN pin input logic, and internal pull-up / down resistance (semi-custom).

The IC's internal regulator circuit can be placed in stand-by mode via the EN function (XC6402C series). In the stand-by mode, power consumption is greatly reduced.

The XC6402F series offers the option of a delay on the detector output: the delay time can be controlled by the use of an external capacitor.

■ APPLICATIONS

- CD-ROM, CD-R / RW drive
- DVD drive
- HDD drive
- Cameras, Video recorders
- Portable AV equipment
- Battery powered equipment

■ FEATURES

- Maximum Output Current : more than 700mA (800mA limit)
(1.6V \leq VR_{OUT}(T) \leq 5.0V)
- Dropout Voltage : 50mV @ I_{OUT}=100mA
- Maximum Operating Voltage : 1.5V ~ 6.0V
- VR Output Voltage Range : 0.8V ~ 5.0V (50mV step)
- VD Output Voltage Range : 0.8V ~ 5.0V (50mV step)
When monitoring VIN : more than 1.5V
- Highly Accurate : \pm 2%
- Low Power Consumption : 35 μ A (TYP.)
- High Ripple Rejection : 60dB (@1kHz)
- Operational Ambient Temperature: : - 40 ~ 85°C
- Low ESR Capacitor Compatible : Ceramic capacitor
- Ultra Small Packages : SOT-25 (SOT-23-5)
: SOT-89-5
: USP-6B

* VD: Voltage Detector

■ TYPICAL APPLICATIONS CIRCUITS

○ XC6402C Series

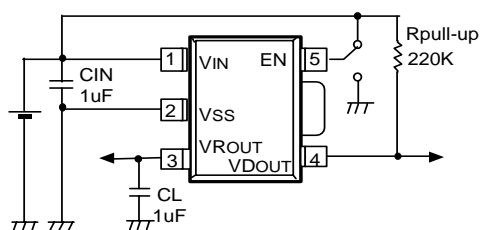

○ XC6402F Series

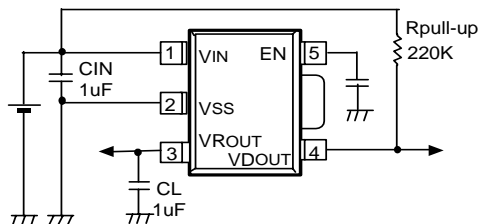

■ TYPICAL PERFORMANCE CHARACTERISTICS

○ Dropout Voltage vs. VR Output Current

XC6402 Series (VR : 3.0V)

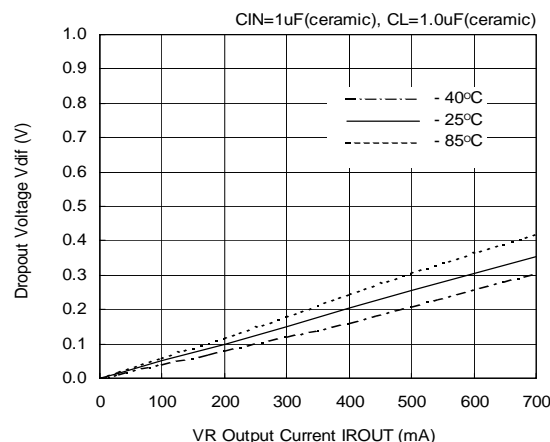

XC6402 Series

High Current, High Speed LDO Regulators, Voltage Detector Function

PIN CONFIGURATION

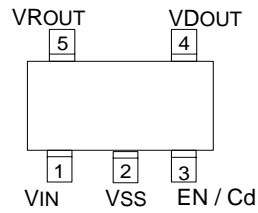

SOT-25 (TOP VIEW)

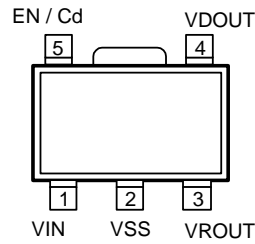

SOT-89-5 (TOP VIEW)

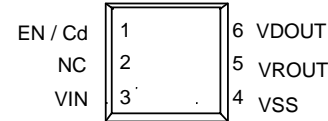

USP-6B (TOP VIEW)

PIN ASSIGNMENT

PIN NUMBER			PIN NAME	FUNCTION
SOT-25	SOT-89-5	USP-6B		
1	1	3	VIN	Power Input
2	2	4	VSS	Ground
5	3	5	VROUT	VR Output
4	4	6	VDOUT	VD Output
3	5	1	EN	VR ON/OFF Control (C Series)
3	5	1	Cd	Delay Capacitor Connection (F Series)
-	-	2	NC	No Connection

SELECTION GUIDE

1. EN Input Logic, Internal Pull-up / down as option

SERIES	CE INPUT LOGIC
XC6402 * A ~ D	Active High with pull-down resistance
XC6402 * E ~ K	Active High with no pull-down resistance
XC6402 * L ~ P	Active Low with pull-up resistance
XC6402 * R ~ U	Active Low with no pull-up resistance

* : C series

2. VD Sense as option

SERIES	VD SENSE PIN
XC6402 * A, B, E, F, L, M, R, S, V, X	VIN
XC6402 * C, D, H, K, N, P, T, U, Y, Z	VROUT

* : C and F series

3. VD Output Logic as option

SERIES	VD OUTPUT LOGIC
XC6402 * A, C, E, H, L, N, R, T, V, Y	Detect L
XC6402 * B, D, F, K, M, P, S, U, X, Z	Detect H

* : C and F series

XC6402 Series

High Current, High Speed LDO Regulators, Voltage Detector Function

ORDERING INFORMATION

XC6402 ①②③④⑤⑥

PIN NUMBER	FUNCTION	PIN NUMBER	FUNCTION
①	Denotes Optional Functions : C : EN Function F : Cd Pin	⑤	Denotes Packaging Types: M : SOT-25 (SOT-23-5) P : SOT-89-5 D : USP-6B
②	Denotes Types : As in the chart below.	⑥	Denotes Taping Direction: R: Embossed tape, Standard feed L : Embossed tape, Reverse feed
③ ④	Internally set sequential number relating to output voltage and detect voltage. VR Setting Output Voltage Range : 0.8V ~ 5.0V Detect Voltage Setting Range : 0.8V ~ 5.0V 50mV increments are available		

PIN NUMBER : ② Types

②	EN FUNCTION	EN LOGIC	PULL UP/DOWN RESISTANCE	VD SENSE PIN	VD OUTPUT LOGIC	PIN NUMBER ①
A	Functional	Active High	Pull-down Function	VIN	Detect L	C Series
B	Functional	Active High	Pull-down Function	VIN	Detect H	
C	Functional	Active High	Pull-down Function	VROUT	Detect L	
D	Functional	Active High	Pull-down Function	VROUT	Detect H	
E	Functional	Active High	Nonfunctional	VIN	Detect L	
F	Functional	Active High	Nonfunctional	VIN	Detect H	
H	Functional	Active High	Nonfunctional	VROUT	Detect L	
K	Functional	Active High	Nonfunctional	VROUT	Detect H	
L	Functional	Active Low	Pull-up Function	VIN	Detect L	
M	Functional	Active Low	Pull-up Function	VIN	Detect H	
N	Functional	Active Low	Pull-up Function	VROUT	Detect L	
P	Functional	Active Low	Pull-up Function	VROUT	Detect H	
R	Functional	Active Low	Nonfunctional	VIN	Detect L	
S	Functional	Active Low	Nonfunctional	VIN	Detect H	
T	Functional	Active Low	Nonfunctional	VROUT	Detect L	
U	Functional	Active Low	Nonfunctional	VROUT	Detect H	
V	Nonfunctional	-	-	VIN	Detect L	F Series
X	Nonfunctional	-	-	VIN	Detect H	
Y	Nonfunctional	-	-	VROUT	Detect L	
Z	Nonfunctional	-	-	VROUT	Detect H	

XC6402 Series

High Current, High Speed LDO Regulators, Voltage Detector Function

PACKAGING INFORMATION

○ SOT-25 (SOT-23-5)

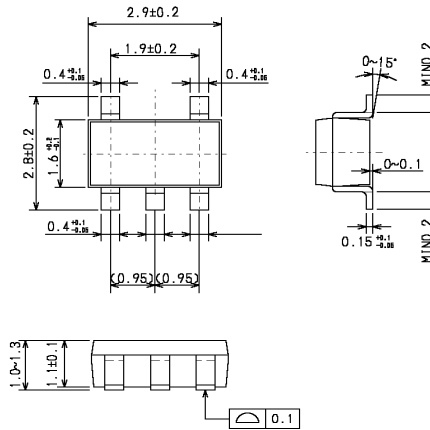

○ SOT-89-5

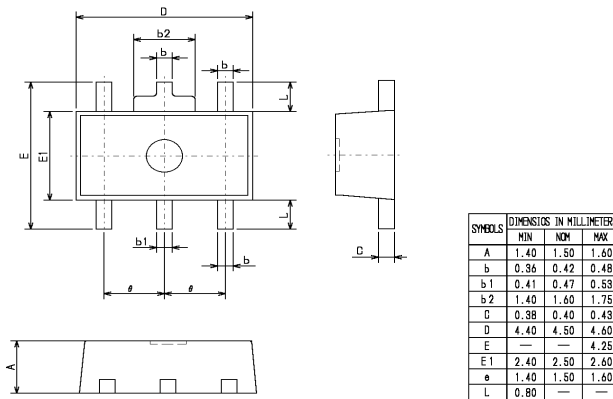

○ USP-6B

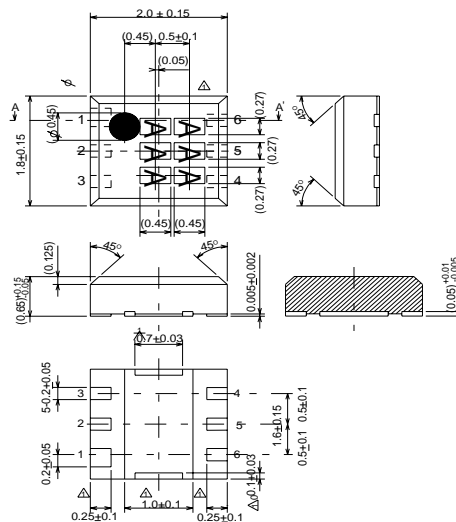

XC6402 Series

High Current, High Speed LDO Regulators, Voltage Detector Function

■ BLOCK DIAGRAM

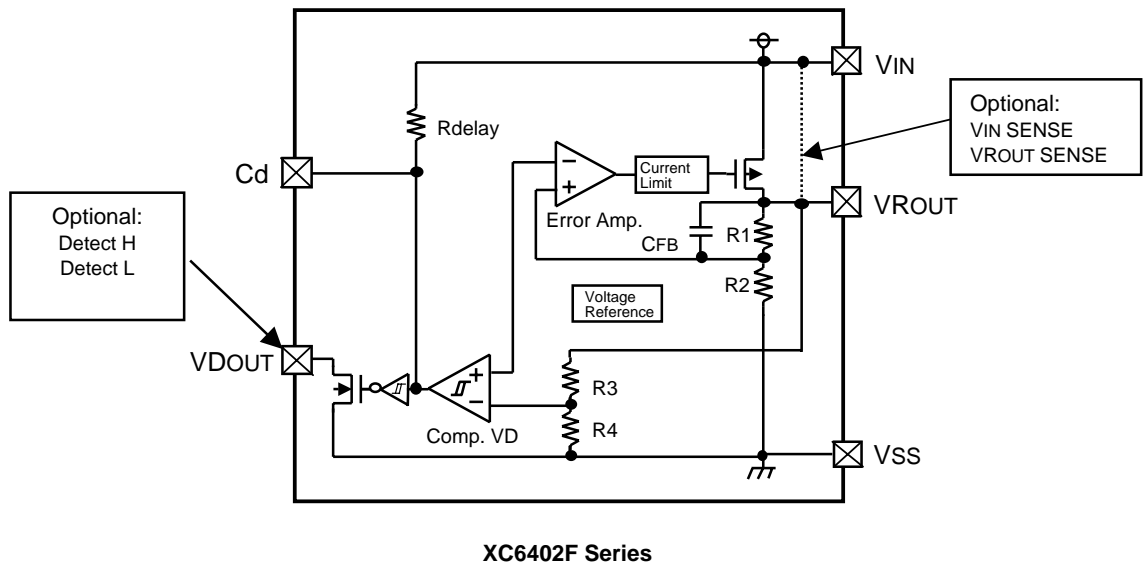
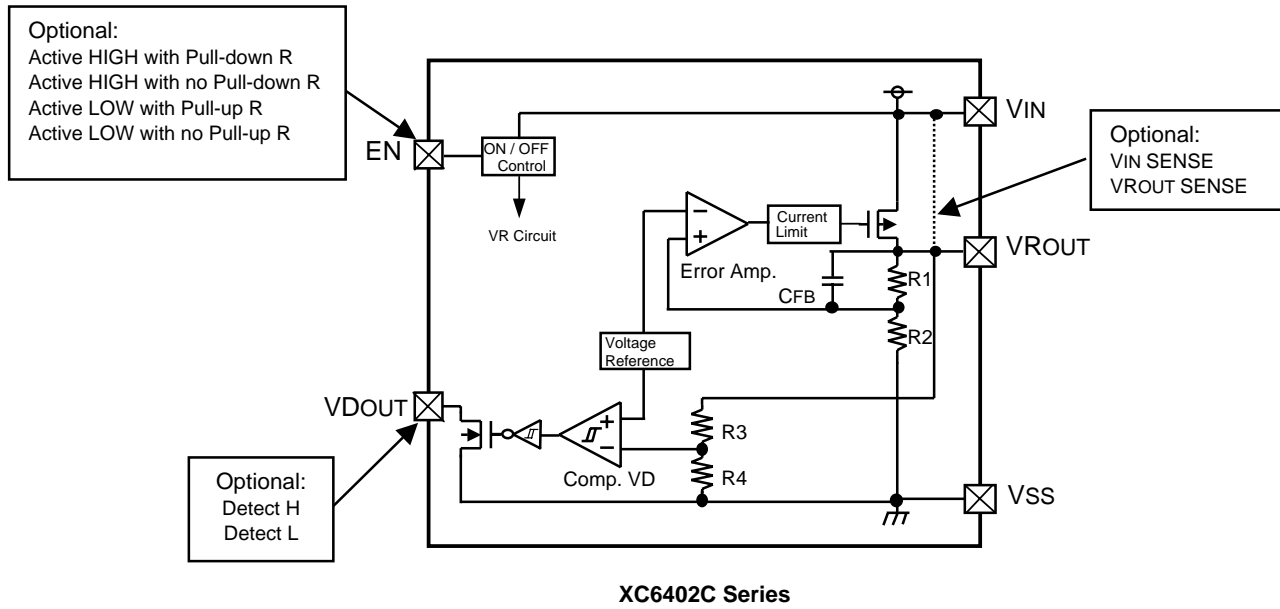

XC6402 Series

High Current, High Speed LDO Regulators, Voltage Detector Function

■ ABSOLUTE MAXIMUM RATINGS

Ta=25°C

PARAMETER	SYMBOL	RATINGS	UNITS
Input Voltage	VIN	6.5	V
VR Output Current	IROUT	800	mA
VR Output Voltage	VROUT	VSS -0.3 ~ VIN +0.3	V
VD Output Current	IDOUT	50	mA
VD Output Voltage	VDOUT	VSS -0.3 ~ 6.5	V
VEN / Cd Pin Voltage	VEN / Cd	VSS -0.3 ~ VIN + 0.3	V
Continuous Power Dissipation	SOT-25	250	mW
	SOT-89-5	500	
	USP-6B	100	
Operating Temperature Range	Topr	- 40 ~ + 85	°C
Storage Temperature Range	Tstg	- 55 ~ + 125	°C

■ ELECTRICAL CHARACTERISTICS

XC6402C Series

Ta=25°C

	PARAMETER	SYMBOL	CONDITIONS	MIN	TYP	MAX	UNITS	CIRCUIT
VOLTAGE REGULATOR (VROUT=1.8V)	VR Output Voltage (note 2, 3)	VROUT(E)	VIN=VROUT(T)+1.0V, IROUT=30mA	x 0.98 (-30mV)	VROUT(T)	x 1.02 (+30mV)	V	①
	VR Maximum Output Current [VROUT(E)≥1.6V]	IROUTMAX	VIN=VROUT(T)+1.0V VEN=ON(VIN or VSS)	700	-	-	mA	①
	VR Maximum Output Current [VROUT(E)<1.6V]	IROUTMAX	VIN=VROUT(T)+1.0V VEN=ON(VIN or VSS)	500	-	-	mA	①
	VR Load Regulation	ΔVROUT	1mA≤IROUT≤100mA	-	15	60	mV	①
	VR Dropout Voltage (note 4)	Vdif1	IROUT=30mA	E-1 (page 8 ~9)			mV	①
		Vdif2	IROUT=100mA	E-2 (page 8 ~9)				
	Supply Current (CA/CB/CC/CD type)	IDD	VEN=VIN=VROUT(T)+1.0V, IROUT=0mA	E-3 (page 8 ~9)			μA	②
	Supply Current (CL/CM/CN/CP type)	IDD	VEN=VROUT(T)+1.0V, VIN=VSS, IROUT=0mA	E-3 (page 8 ~9)			μA	②
	Supply Current (CE/CF/CH/CK type)	IDD	VEN=VIN=VROUT(T)+1.0V, IROUT=0mA	-	35	70	μA	②
	Supply Current (CR/CS/CT/CU type)	IDD	VEN=VROUT(T)+1.0V, VIN=VSS, IROUT=0mA	-	35	70	μA	②
	VR Line Regulation	$\frac{\Delta VROUT}{\Delta VIN \cdot VROUT}$	VROUT(T)+1.0V≤VIN≤6.0V VEN=ON(VIN or VSS), IROUT=30mA	-	0.01	0.20	% / V	①
	Input Voltage	VIN		1.5	-	6.0	V	-
	VR Output Voltage Temperature Characteristics	$\frac{\Delta VROUT}{\Delta Topr \cdot VROUT}$	IROUT=30mA -40°C≤Topr≤85°C	-	±100	-	ppm / °C	①
	VR Ripple Rejection Rate	PSRR	VIN=[VROUT(T)+1.0]VDC+0.5Vp-pAC When VROUT(T) ≥ 4.75V ⇒ VIN=5.75V+0.5Vp-pAC IROUT=30mA, f=1kHz	-	60	-	dB	③
	VR Current Limiter [VROUT(E)≥1.6V]	IRlim	VIN=VROUT(T)+1.0V VEN=ON(VIN or VSS)	700	800	-	mA	①
	VR Current Limiter [VROUT(E)<1.6V]	IRlim	VIN=VROUT(T)+1.0V VEN=ON(VIN or VSS)	-	800	-	mA	①
Short-Circuit Current	IRshort	VIN=VROUT(T)+1.0V VEN=ON(VIN or VSS)	-	30	-	mA	①	

XC6402 Series

High Current, High Speed LDO Regulators, Voltage Detector Function

ELECTRICAL CHARACTERISTICS (Continued)

XC6402C Series								Ta=25°C	
	PARAMETER	SYMBOL	CONDITIONS	MIN	TYP	MAX	UNITS	CIRCUIT	
VOLTAGE DETECTOR	VD Detect Voltage (note 7, 8)	VDF (E)		x 0.98 (-30mV)	VDF (T)	x 1.02 (+30mV)	V	④	
	VD Hysteresis Range (note 7)	VHYS		VDF (E) x 0.02	VDF (E) x 0.05	VDF (E) x 0.08	V	④	
	VD Supply Current	IDDVD	VEN = OFF (VIN or VSS) VIN = 1.5V VIN = 2.0V VIN = 3.0V VIN = 4.0V VIN = 5.0V VIN = 6.0V	- - - - - -	5.0 5.5 6.0 6.5 7.0 7.5	14.0 14.5 15.0 15.5 16.0 17.0	μA	②	
	VD Output Current (note 9)	IDOUT	VDOUT = 0.5V VIN = 1.5V VIN = 2.0V VIN = 3.0V VIN = 4.0V VIN = 5.0V VIN = 6.0V	1.5 1.8 1.8 1.9 1.9 2.0	3.0 3.5 3.7 3.8 3.9 4.0	- - - - - -	mA	⑤	
	VD Detect Voltage Temperature Characteristics	$\frac{\Delta VDF}{\Delta T_{opr}} \cdot VDF$		-40°C ≤ Topr ≤ 85°C	-	±100	-	ppm / °C	④
	SWITCH	EN "High" Level Voltage	VEN H		1.60	-	VIN	V	①
EN "Low" Level Voltage		VEN L		-	-	0.25	V	①	
EN "High" Level Current (CA/CB/CC/CD type)		IEN H	VEN=VIN=VROUT(T)+1.0V	-0.10	-	E-4 (page 8~9)	μA	①	
EN "High" Level Current (CE/CF/CH/CK/CL/CM/CN/CP/CR/CS/CT/CU type)		IEN H		-0.10	-	0.10	μA	①	
EN "High" Level Current (CL/CM/CN/CP type)		IEN L	VIN=VROUT(T)+1.0V, VEN=VSS	E-5 (page 8~9)	-	0.10	μA	①	
EN "High" Level Current (CA/CB/CC/CD/CE/CF/CH/CK/CR/CS/CT/CU type)		IEN L	VIN=VROUT(T)+1.0V, VEN=VSS	-0.10	-	0.10	μA	①	

(NOTE 1) Unless otherwise stated, VIN=VROUT(T)+1.0V

(NOTE 2) VROUT(T)=Specified VR Output Voltage

(NOTE 3) VROUT(E)=Actual VR Output Voltage.

(i.e. the VR output voltage when "VROUT(T)+1.0V" is provided at the VIN pin while maintaining a certain IROUT value).

(NOTE 4) $V_{dif} = \{VIN1^{(NOTE6)} - VROUT1^{(NOTE5)}\}$

(NOTE 5) A voltage equal to 98% of the VR Output Voltage whenever a stabilized VROUT1=IROUT{VROUT(T)+1.0V} is input.

(NOTE 6) VIN1=The Input Voltage when VOUT1, which appears as Input Voltage is gradually decreased.

(NOTE 7) VDF (T) : Specified Detect Voltage value

(NOTE 8) VDF (E) : Actual Detect Voltage value.

(NOTE 9) VD Output Current value of Detect 'L' type equal to current value during detection and that of Detect 'H' type equal to current value before detection.

(NOTE10) $VROUT(T) \leq 1.45V$, $VDF(T) \leq 1.45V$ ⇒ MIN : VROUT(T) -30mV, VDF(T) -30mV, ⇒ MAX : VROUT(T) +30mV, VDF(T) +30mV

(NOTE11) EN conditions: XC6402CA / CB / CC / CD / CE / CF / CH / CK type : ON=VIN, OFF=VSS
XC6402CL / CM / CN / CP / CR / CS / CT / CU type : ON=VSS, OFF=VIN

(NOTE12) VD detect voltage : For VIN Sense version, XC6402CA / CB / CE / CF / CL / CM / CR / CS, only VDF(T)>1.5V type are available.

XC6402 Series

High Current, High Speed LDO Regulators, Voltage Detector Function

XC6402C SERIES DROPOUT VOLTAGE, SUPPLY CURRENT, EN'H/L' LEVEL CURRENT

SETTING OUTPUT VOLTAGE (V)	VR OUTPUT VOLTAGE VD DETECT VOLTAGE (V) VOUT		E-1		E-2		E-3		E-4		E-5	
			DROPOUT VOLTAGE 1 (mV) Vdif1		DROPOUT VOLTAGE 2 (mV) Vdif2		SUPPLY CURRENT (μ A) IDD		EN'H'LEVEL CURRENT (μ A) IENH		EN'H'LEVEL CURRENT (μ A) IENL	
VROUT(T)	MIN.	MAX.	TYP.	MAX.	TYP.	MAX.	TYP.	MAX.	TYP.	MAX.	TYP.	MAX.
0.80	0.770	0.830	100	700	250	800	38.0	80.0	5.0	-5.0		
0.85	0.820	0.880		600		700						
0.90	0.870	0.930										
0.95	0.920	0.980										
1.00	0.970	1.030	50	500	150	600						
1.05	1.020	1.080		400		500						
1.10	1.070	1.130										
1.15	1.120	1.180	30	300	100	400	38.5	81.5	6.5	-6.5		
1.20	1.170	1.230		200		300						
1.25	1.220	1.280		100		250						
1.30	1.270	1.330										
1.35	1.320	1.380										
1.40	1.370	1.430										
1.45	1.420	1.480										
1.50	1.470	1.530	27.0	41.0	90.0	135.0	39.0	83.0	8.0	-8.0		
1.55	1.519	1.581										
1.60	1.568	1.632										
1.65	1.617	1.683										
1.70	1.666	1.734										
1.75	1.715	1.785										
1.80	1.764	1.836										
1.85	1.813	1.887										
1.90	1.862	1.938										
1.95	1.911	1.989										
2.00	1.960	2.040	25.0	37.0	80.0	120.0	39.5	84.5	9.5	-9.5		
2.05	2.009	2.091										
2.10	2.058	2.142										
2.15	2.107	2.193										
2.20	2.156	2.244										
2.25	2.205	2.295										
2.30	2.254	2.346										
2.35	2.303	2.397										
2.40	2.352	2.448										
2.45	2.401	2.499										
2.50	2.450	2.550	18.0	28.0	60.0	90.0	40.0	86.0	11.0	-11.0		
2.55	2.499	2.601										
2.60	2.548	2.652										
2.65	2.597	2.703										
2.70	2.646	2.754										
2.75	2.695	2.805										
2.80	2.744	2.856										
2.85	2.793	2.907										
2.90	2.842	2.958										
2.95	2.891	3.009										

XC6402 Series

High Current, High Speed LDO Regulators, Voltage Detector Function

■ XC6402C SERIES DROPOUT VOLTAGE, SUPPLY CURRENT, EN'H/L' LEVEL CURRENT (Continued)

SETTING OUTPUT VOLTAGE (V)	VR OUTPUT VOLTAGE VD DETECT VOLTAGE (V)		E-1		E-2		E-3		E-4		E-5	
			DROPOUT VOLTAGE 1 (mV)		DROPOUT VOLTAGE 2 (mV)		SUPPLY CURRENT (μ A)		EN'H'LEVEL CURRENT (μ A)		EN'H'LEVEL CURRENT (μ A)	
	VOUT		Vdif1		Vdif2		IDD		IENH		IENL	
VROUT(T)	MIN.	MAX.	TYP.	MAX.	TYP.	MAX.	TYP.	MAX.	TYP.	MAX.	TYP.	MAX.
3.00	2.940	3.060	15.0	23.0	50.0	75.0	40.5	87.5	12.5	-12.5		
3.05	2.989	3.111										
3.10	3.038	3.162										
3.15	3.087	3.213										
3.20	3.136	3.264										
3.25	3.185	3.315										
3.30	3.234	3.366										
3.35	3.283	3.417										
3.40	3.332	3.468										
3.45	3.381	3.159										
3.50	3.430	3.570										
3.55	3.479	3.621										
3.60	3.528	3.672										
3.65	3.577	3.723										
3.70	3.626	3.774										
3.75	3.675	3.825										
3.80	3.724	3.876										
3.85	3.773	3.927										
3.90	3.882	3.978										
3.95	3.871	4.029										
4.00	3.920	4.080										
4.05	3.969	4.131										
4.10	4.018	4.182										
4.15	4.067	4.233										
4.20	4.116	4.284										
4.25	4.165	4.335										
4.30	4.214	4.386										
4.35	4.263	4.437										
4.40	4.312	4.488										
4.45	4.361	4.539										
4.50	4.410	4.590										
4.55	4.459	4.641										
4.60	4.508	4.692										
4.65	4.557	4.743										
4.70	4.606	4.794										
4.75	4.655	4.845										
4.80	4.704	4.896										
4.85	4.753	4.947										
4.90	4.802	4.998										
4.95	4.851	5.049										
5.00	4.900	5.100										

XC6402 Series

High Current, High Speed LDO Regulators, Voltage Detector Function

ELECTRICAL CHARACTERISTICS

XC6402F Series

Ta=25°C

	PARAMETER	SYMBOL	CONDITIONS	MIN	TYP	MAX	UNITS	CIRCUIT
VOLTAGE REGULATOR	VR Output Voltage (note 2, 3)	VROUT(E)	VIN=VROUT(T)+1.0V, IROUT=30mA	x 0.98 (-30mV)	VROUT(T)	x 1.02 (+30mV)	V	①
	VR Maximum Output Current [VROUT(E)≥1.6V]	IROUTMAX	VIN=VROUT(T)+1.0V	700	-	-	mA	①
	VR Maximum Output Current [VROUT(E)<1.6V]	IROUTMAX	VIN=VROUT(T)+1.0V	500	-	-	mA	①
	VR Load Regulation	ΔVROUT	1mA≤IROUT≤100mA	-	15	60	mV	①
	VR Dropout Voltage (note 4)	Vdif1	IROUT=30mA	E-1 (page 11~12)			mV	①
		Vdif2	IROUT=100mA	E-2 (page 11~12)				
	Supply Current	IDD	VIN=VROUT(T)+1.0V	-	35	70	μA	②
	VR Line Regulation	$\frac{\Delta VROUT}{\Delta VIN \cdot VROUT}$	VROUT(T)+1.0V≤VIN≤6.0V IROUT=30mA	-	0.01	0.20	% / V	①
	Input Voltage	VIN		1.5	-	6.0	V	-
	VR Output Voltage Temperature Characteristics	$\frac{\Delta VROUT}{\Delta Topr \cdot VROUT}$	IROUT=30mA -40°C≤Topr≤85°C	-	±100	-	ppm / °C	①
	VR Ripple Rejection Rate	PSRR	VIN=[VROUT(T)+1.0]VDC+0.5Vp-pAC When VROUT(T) ≥ 4.75V ⇒ VIN=5.75V+0.5Vp-pAC IROUT=30mA, f=1kHz	-	60	-	dB	③
	VR Current Limiter [VROUT(E)≥1.6V]	IRlim	VIN=VROUT(T)+1.0V	700	800	-	mA	①
VR Current Limiter [VROUT(E)<1.6V]	IRlim	VIN=VROUT(T)+1.0V	-	800	-	mA	①	
Short-Circuit Current	IRshort	VIN=VROUT(T)+1.0V	-	30	-	mA	①	
VOLTAGE DETECTOR	VD Detect Voltage (note 7, 8)	VDF (E)		x 0.98 (-30mV)	VDF (T)	x 1.02 (+30mV)	V	④
	VD Hysteresis Range (note 7)	VHYS		VDF (E) x 0.02	VDF (E) x 0.05	VDF (E) x 0.08	V	④
	VD Output Current (note 9)	IDOUT	VROUT=0.5V	-	1.5	3.0	μA	⑤
			VIN = 1.5V	-	1.8	3.5		
			VIN = 2.0V	-	1.8	3.7		
			VIN = 3.0V	-	1.9	3.8		
VIN = 4.0V			-	1.9	3.9			
VD Detect Voltage Temperature Characteristics	$\frac{\Delta VDF}{\Delta Topr \cdot VDF}$	-40°C≤Topr≤85°C	-	±100	-	ppm / °C	④	
Delay Resistance	Rdelay	VIN=6.0V, Vcd=0V	1.0	2.0	3.5	MΩ	⑥	

(NOTE 1) Unless otherwise stated, VIN=VROUT(T)+1.0V

(NOTE 2) VROUT(T)=Specified VR Output Voltage

(NOTE 3) VROUT(E)=Actual VR Output Voltage.

(i.e. the VR output voltage when "VROUT(T)+1.0V" is provided at the VIN pin while maintaining a certain IROUT value).

(NOTE 4) $Vdif=\{VIN1^{(NOTE6)}-VROUT1^{(NOTE5)}\}$

(NOTE 5) A voltage equal to 98% of the VR Output Voltage whenever a stabilized VROUT1=IROUT{VROUT(T)+1.0V} is input.

(NOTE 6) VIN1=The Input Voltage when VOUT1, which appears as Input Voltage is gradually decreased.

(NOTE 7) VDF (T) : Specified Detect Voltage value

(NOTE 8) VDF (E) : Actual Detect Voltage value.

(NOTE 9) VD Output Current value of Detect 'L' type equal to current value during detection and that of Detect 'H' type equal to current value before detection.

(NOTE10) VROUT(T)≤1.45V, VDF(T)≤1.45V

⇒ MIN : VROUT(T) -30mV, VDF(T) -30mV,

⇒ MAX : VROUT(T) +30mV, VDF(T) +30mV

(NOTE11) VD detect voltage : For VIN Sense version, XC6402FV / FX, only VDF(T)>1.5V type are available.

XC6402 Series

High Current, High Speed LDO Regulators, Voltage Detector Function

XC6402F SERIES DROPOUT VOLTAGE

SETTING OUTPUT VOLTAGE (V)	VR OUTPUT VOLTAGE		E-1		E-2			
	VD DETECT VOLTAGE (V)		DROPOUT VOLTAGE 1 (mV)		DROPOUT VOLTAGE 2 (mV)			
	VOUT		Vdif1		Vdif2			
VROUT(T)	MIN.	MAX.	TYP.	MAX.	TYP.	MAX.		
0.80	0.770	0.830	100	700	250	800		
0.85	0.820	0.880		600		700		
0.90	0.870	0.930		50		500	150	600
0.95	0.920	0.980				400		500
1.00	0.970	1.030	30	300	100	400		
1.05	1.020	1.080		200		100	300	
1.10	1.070	1.130						100
1.15	1.120	1.180		27.0		41.0	90.0	
1.20	1.170	1.230	25.0	37.0	80.0	120.0		
1.25	1.220	1.280						
1.30	1.270	1.330						
1.35	1.320	1.380						
1.40	1.370	1.430						
1.45	1.420	1.480						
1.50	1.470	1.530						
1.55	1.519	1.581						
1.60	1.568	1.632						
1.65	1.617	1.683						
1.70	1.666	1.734						
1.75	1.715	1.785						
1.80	1.764	1.836						
1.85	1.813	1.887						
1.90	1.862	1.938						
1.95	1.911	1.989						
2.00	1.960	2.040	18.0	28.0	60.0	90.0		
2.05	2.009	2.091						
2.10	2.058	2.142						
2.15	2.107	2.193						
2.20	2.156	2.244						
2.25	2.205	2.295						
2.30	2.254	2.346						
2.35	2.303	2.397						
2.40	2.352	2.448						
2.45	2.401	2.499						
2.50	2.450	2.550						
2.55	2.499	2.601						
2.60	2.548	2.652						
2.65	2.597	2.703						
2.70	2.646	2.754						
2.75	2.695	2.805						
2.80	2.744	2.856						
2.85	2.793	2.907						
2.90	2.842	2.958						
2.95	2.891	3.009						

XC6402 Series

High Current, High Speed LDO Regulators, Voltage Detector Function

■ XC6402F SERIES DROPOUT VOLTAGE (Continued)

SETTING OUTPUT VOLTAGE (V)	VR OUTPUT VOLTAGE		E-1		E-2	
	VD DETECT VOLTAGE (V)		DROPOUT VOLTAGE 1 (mV)		DROPOUT VOLTAGE 2 (mV)	
	VOUT		Vdif1		Vdif2	
VROUT(T)	MIN.	MAX.	TYP.	MAX.	TYP.	MAX.
3.00	2.940	3.060				
3.05	2.989	3.111				
3.10	3.038	3.162				
3.15	3.087	3.213				
3.20	3.136	3.264				
3.25	3.185	3.315				
3.30	3.234	3.366				
3.35	3.283	3.417				
3.40	3.332	3.468				
3.45	3.381	3.519				
3.50	3.430	3.570				
3.55	3.479	3.621				
3.60	3.528	3.672				
3.65	3.577	3.723				
3.70	3.626	3.774				
3.75	3.675	3.825				
3.80	3.724	3.876				
3.85	3.773	3.927				
3.90	3.882	3.978				
3.95	3.871	4.029				
4.00	3.920	4.080	15.0	23.0	50.0	75.0
4.05	3.969	4.131				
4.10	4.018	4.182				
4.15	4.067	4.233				
4.20	4.116	4.284				
4.25	4.165	4.335				
4.30	4.214	4.386				
4.35	4.263	4.437				
4.40	4.312	4.488				
4.45	4.361	4.539				
4.50	4.410	4.590				
4.55	4.459	4.641				
4.60	4.508	4.692				
4.65	4.557	4.743				
4.70	4.606	4.794				
4.75	4.655	4.845				
4.80	4.704	4.896				
4.85	4.753	4.947				
4.90	4.802	4.998				
4.95	4.851	5.049				
5.00	4.900	5.100				

XC6402 Series

High Current, High Speed LDO Regulators, Voltage Detector Function

TEST CIRCUITS

XC6402C Series

○ Circuit ①

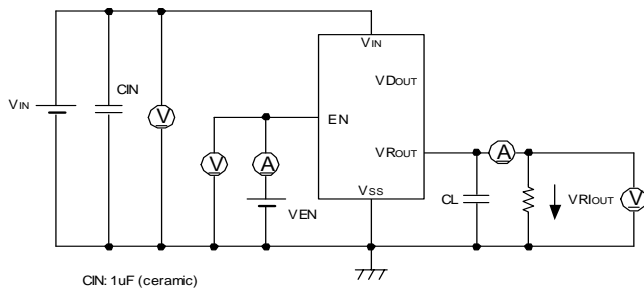

○ Circuit ②

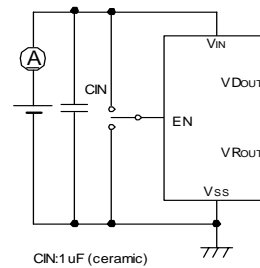

○ Circuit ③

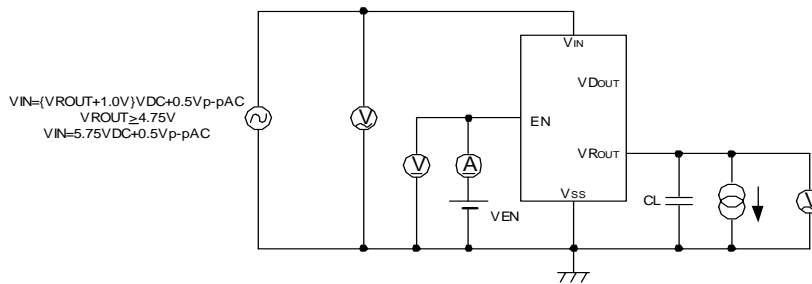

○ Circuit ④

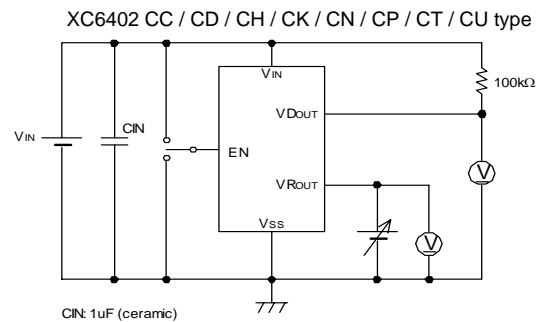
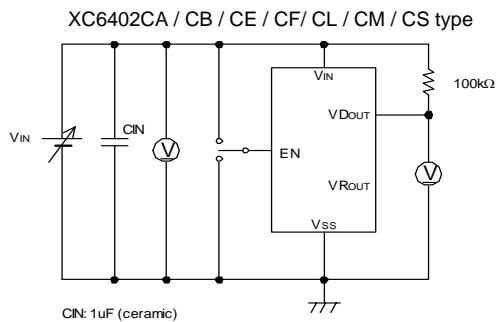

○ Circuit ⑤

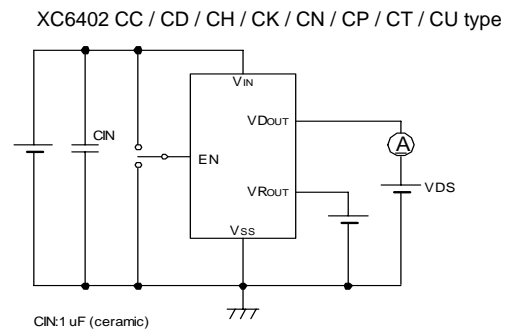
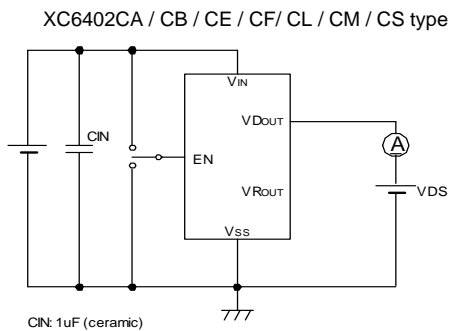

Output Capacitor Corresponding Chart

VR OUTPUT VOLTAGE	0.8 ~ 1.45V	1.5 ~ 1.75V	1.8V ~ 5.0V
CL	6.8μF	2.2μF	1.0μF

XC6402 Series

High Current, High Speed LDO Regulators, Voltage Detector Function

TEST CIRCUITS (Continued)

XC6402F Series

○ Circuit ①

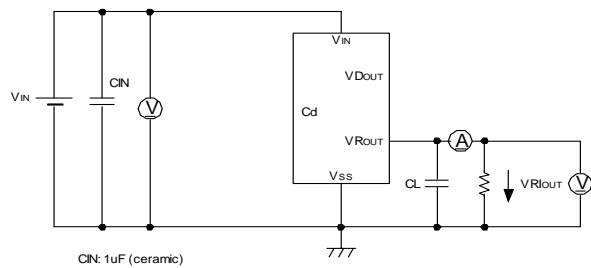

○ Circuit ②

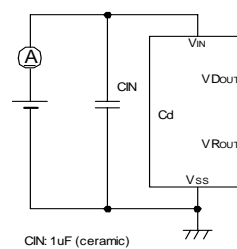

○ Circuit ③

$$V_{IN} = (V_{ROUT} + 1.0V) / V_{DC} + 0.5V_{p-pAC}$$

$$V_{ROUT} \geq 4.75V$$

$$V_{IN} = 5.75V_{DC} + 0.5V_{p-pAC}$$

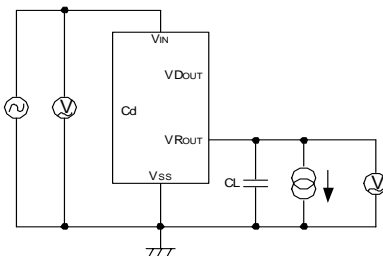

○ Circuit ④

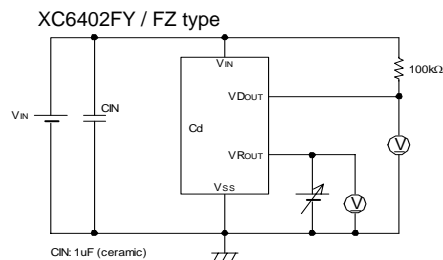
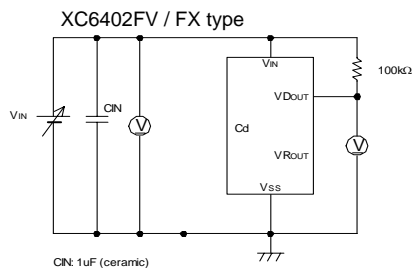

○ Circuit ⑤

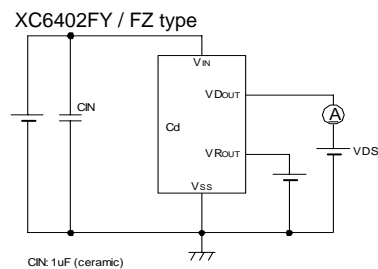
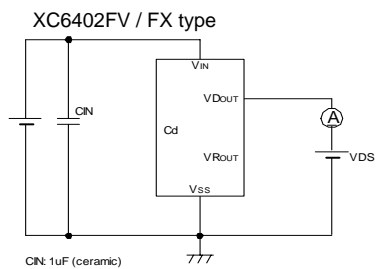

○ Circuit ⑥

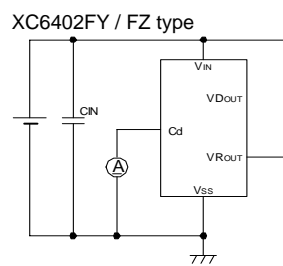
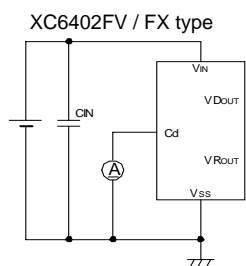

Output Capacitor Corresponding Chart

VR OUTPUT VOLTAGE	0.8 ~ 1.45V	1.5 ~ 1.75V	1.8V ~ 5.0V
CL	6.8μF	2.2μF	1.0μF

XC6402 Series

High Current, High Speed LDO Regulators, Voltage Detector Function

■ OPERATIONAL EXPLANATION

<Output voltage regulator control>

The voltage, divided by resistors R1 & R2 which are connected to the VROUT pin is compared with the internal reference voltage by the error amplifier. The P-Channel MOSFET, which is connected to the VROUT pin, is then driven by the subsequent output signal. The output voltage at the VROUT pin is controlled & stabilized by negative feedback. The current limit circuit and short circuit protection operate in relation to the level of output current. Further, the voltage regulator's internal circuitry can be shutdown via the EN pin's signal.

<Detector function with the XC6402 series>

The series' detector function monitors the voltage divided by resistors R3 & R4 which are connected to the VROUT pin or the VIN pin, as well as monitoring the voltage of the internal reference voltage source via the comparator. The VDSEN pin has options (please refer to the Selection Guide, item 2 on page 2). A 'High' or 'Low' signal level can be output from the VDOUT pin when the VD pin voltage level goes below the detect voltage. The VD output logic has options (please refer to the Selection Guide, item 3 on page 2). As VDOUT is an open-drain N-channel output, a pull-up resistor of about 220KΩ is needed to achieve a voltage output. Because of hysteresis at the detector function, output at the VDOUT pin will invert when the detect voltage level increases above the release voltage (105% of the detect voltage).

For the XC6402C type, in stand-by, if a voltage of the recovery voltage is present at the VROUT pin (from another power source), the VDOUT pin will be high impedance mode, and the pull up voltage will be output at VDOUT. By connecting the Cdelay pin to a capacitor (Cd), the XC6402F series can apply a delay time to VDOUT voltage when releasing voltage. The delay time can be calculated from the internal resistance, Rdelay (2MΩ TYP. fixed) and the value of Cd as per the following equation.

$$\text{Delay Time} = C_{\text{delay}} \times R_{\text{delay}} \times 0.7$$

Delay Time	Rdelay standard : 1.0 ~ 3.5MΩ	TYP : 2.0MΩ
Cdelay	DELAY TIME (TYP.)	DELAY TIME (TYP.)
0.01 μF	14 msec	7.0 ~ 24.5 msec
0.022 μF	30.8 msec	15.4 ~ 53.9 msec
0.047 μF	65.8 msec	32.9 ~ 115.15 msec
0.1 μF	140 msec	70.0 ~ 245.0 msec
0.22 μF	308 msec	154.0 ~ 539.0 msec
0.47 μF	658 msec	329.0 ~ 1151.5 msec
1 μF	1400 msec	700.0 ~ 2450.0 msec

<Low ESR Capacitors>

With the XC6402 series regulator, a stable output voltage is achievable even if low ESR capacitors are used, as a phase compensation circuit is built-in to the regulator. In order to ensure the effectiveness of the phase compensation, we suggest that an output capacitor (CL) be connected as close as possible, between the output pin (VROUT) and the VSS pin. Please use an output capacitor (CL) with a capacitance, based on the chart below. We also suggest an input capacitor (CIN) of 1μF : this should be connected between VIN and VSS in order to stabilize input power source.

Output Capacitor Corresponding Chart

VR OUTPUT VOLTAGE	0.8 ~ 1.45V	1.5 ~ 1.75V	1.8V ~ 5.0V
CL	6.8μF	2.2μF	1.0μF

<Current Limiter, Short-Circuit Protection>

The XC6402 series regulator offers a combination of current limit and circuit protection by means of a built-in fixed current limiter circuit and a foldback circuit. When the load current reaches the current limit level, the fixed current limiter circuit operates and output voltage drops. As a result of this drop in output voltage, the foldback circuit operates, the output voltage drops further and output current decreases. When the output pin is shorted, a current of about 30mA flows.

XC6402 Series

High Current, High Speed LDO Regulators, Voltage Detector Function

■ OPERATIONAL EXPLANATION (Continued)

<EN Pin>

The IC's internal regulator circuitry can be shut down via the signal from the EN pin with the XC6402C series. In shutdown mode, output at the VROUT pin will be pulled down to the VSS level via R1 & R2. Note that as the XC6402*E to K types of the XC6402C series are 'Active HIGH / No Pull-Down' and XC6402*R to U types of the XC6402C series are 'Active LOW / No Pull-Up', operations will become unstable with the EN pin open (See the chart below).

SERIES	EN INPUT LOGIC
XC6402C A ~ D	Active HIGH with pull-down resistor
XC6402C E ~ K	Active HIGH with no pull-down resistor
XC6402C L ~ P	Active LOW with pull-up resistor
XC6402C R ~ U	Active LOW with no pull-up resistor

We suggest that you use this IC with either a VIN voltage or a VSS voltage input at the EN pin. If this IC is used with the correct specifications for the EN pin, the IC will operate normally. However, supply current may increase as a result of through current in the IC's internal circuitry if a voltage other than VIN or VSS is applied.

■ NOTES ON USE

1. Please use this IC within the stated absolute maximum ratings. The IC is liable to malfunction should the ratings be exceeded.
2. Where wiring impedance is high, operations may become unstable due to noise and/or phase lag depending on output current.
Please strengthen VIN and VSS wiring in particular.
3. Please wire the input capacitor (CIN) and the output capacitor (CL) as close to the IC as possible.
Should rapid input fluctuation or load fluctuation occur, please increase the capacitor value such as CIN or CL to stabilize the operation.