



Features

- Internal regulator provides a stable 5V reference supply trimmed to 5%
- Uncommitted output TR for 200mA sink or source current
- Output control for push-pull or single-ended operation
- Variable duty cycle by dead time control (pin 4) Complete PWM control circuit
- On-chip oscillator with master or slave operation
- Internal circuit prohibits double pulse at either output

Description

The AMS494 is used for the control circuit of the PWM switching regulator. The AMS494 consists of 5V reference voltage circuit, two error amplifiers, flip flop, an output control circuit, a PWM comparator, a dead time comparator and an oscillator. This device can be operated in the switching frequency of 1 KHz to 300 KHz.

PIN CONFIGURATION

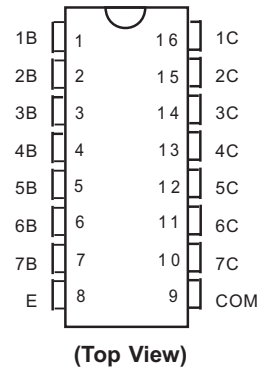

Internal Block Diagram

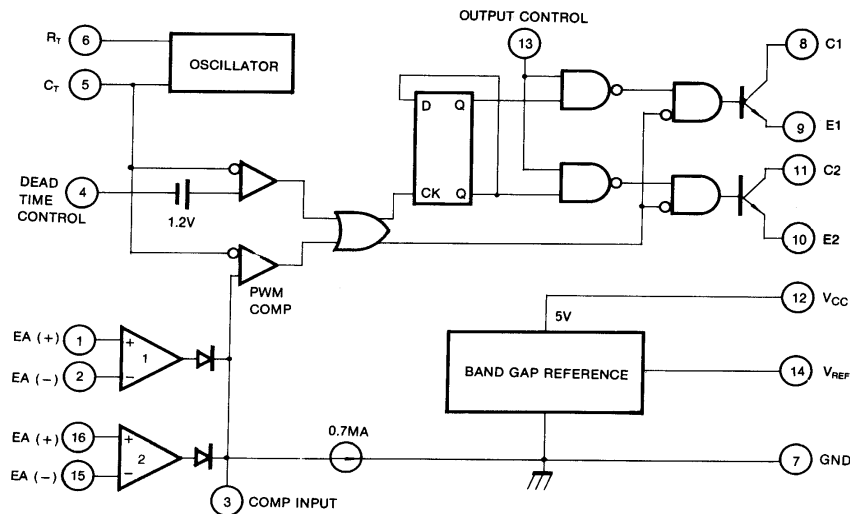



Absolute Maximum Ratings

Parameter	Symbol	Value	Unit
Supply Voltage	V _{CC}	42	V
Collector Supply Voltage	V _C	42	V
Output Current	I _O	250	mA
Amplifier Input Voltage	V _{IN}	V _{CC} + 0.3	V
Power Dissipation (T _A = 25°C)	P _D	1 (AMS494CN) 0.9 (AMS494CD)	W
Operating Temperature Range	T _{OPR}	0 ~ +70	°C
Storage Temperature Range	T _{STG}	-65 ~ + 150	°C



Electrical Characteristics

(VCC = 20V, f = 10KHz, TA = 0°C to + 70°C, unless otherwise specified)

Parameter	Symbol	Conditions	Min.	Typ.	Max.	Unit
REFERENCE SECTION						
Reference Output Voltage	VREF	IREF = 1mA	4.75	5.0	5.25	V
Line Regulation	ΔVREF	VCC = 7V to 40V	-	2.0	25	mV
Temperature Coefficient of VREF	ΔVREF/ΔT	TA = 0°C to 70°C	-	0.01	0.03	%/°C
Load Regulation	ΔVREF	IREF = 1mA to 10mA	-	1.0	15	mV
Short-Circuit Output Current	ISC	VREF = 0V	10	35	50	mA
OSCILLATOR SECTION						
Oscillation Frequency	f	CT = 0.01μF, RT = 12KΩ	-	10	-	KHz
Frequency Change with Temperature	Δf/ΔT	CT = 0.01μF, RT = 12KΩ	-	-	2	%
DEAD TIME CONTROL SECTION						
Input Bias Current	IBIAS	VCC = 15V, 0V ≤ V4 ≤ 5.25V	-	-2.0	-10	μA
Maximum Duty Cycle	D(MAX)	VCC = 15V, V4 = 0V O.C Pin = VREF	45	-	-	%
Input Threshold Voltage	VITH	Zero Duty Cycle	-	3.0	3.3	V
		Max. Duty Cycle	0	-	-	
ERROR AMP SECTION						
Input Offset Voltage	VIO	V3 = 2.5V	-	2.0	10	mV
Input Offset Current	IIO	V3 = 2.5V	-	25	250	mA
Input Bias Current	IBIAS	V3 = 2.5V	-	0.2	1.0	μA
Common Mode Input Voltage	VCM	7V ≤ VCC ≤ 40V	-0.3	-	VCC	V
Open-Loop Voltage Gain	GVO	0.5V ≤ V3 ≤ 3.5V	70	95	-	dB
Unit-Gain Bandwidth	BW	-	-	650	-	KHz
PWM COMPARATOR SECTION						
Input Threshold Voltage	VITH	Zero Duty Cycle	-	4	4.5	V
Input Sink Current	ISINK	V3=0.7V	-0.3	-0.7	-	mV
OUTPUT SECTION						
Output Saturation Voltage Common Emitter	VCE(SAT)	VE = 0, IC = 200mA	-	1.1	1.3	V
Common Collector	VCC(SAT)	VC = 15V, IE = -200mA	-	1.5	2.5	
Collector Off-State Current	IC(OFF)	VCC = 40V, VCE = 40V	-	2	100	μA
Emitter Off-State Current	IE(OFF)	VCC = VC = 40V, VE = 0	-	-	-100	
TOTAL DEVICE						
Supply Current	ICC	Pin 6 = VREF, VCC = 15V	-	6	10	mA
OUTPUT SWITCHING CHARACTERISTIC						
Rise Time	tR	-	-	-	-	-
Common Emitter	-	-	-	100	200	ns
Common Collector	-	-	-	100	200	
Fall Time	tF	-	-	-	-	-
Common Emitter	-	-	-	25	100	ns
Common Collector	-	-	-	40	100	



Typical Application

Pulse Width Modulated Step-down Converter

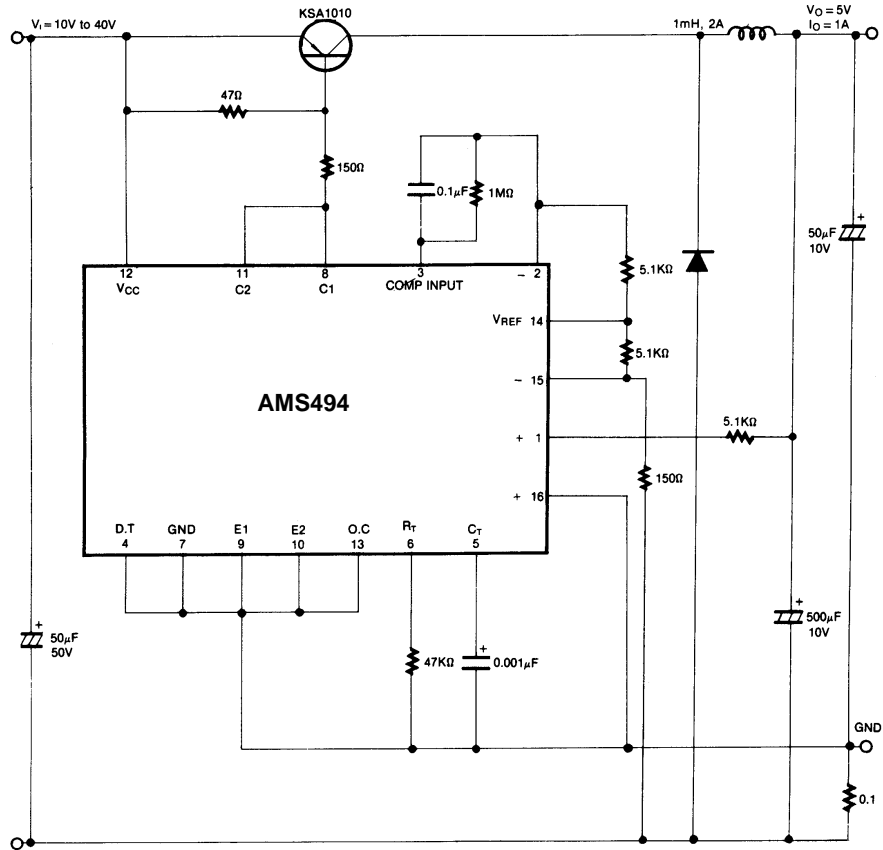



Mechanical Dimensions

Package

16-DIP

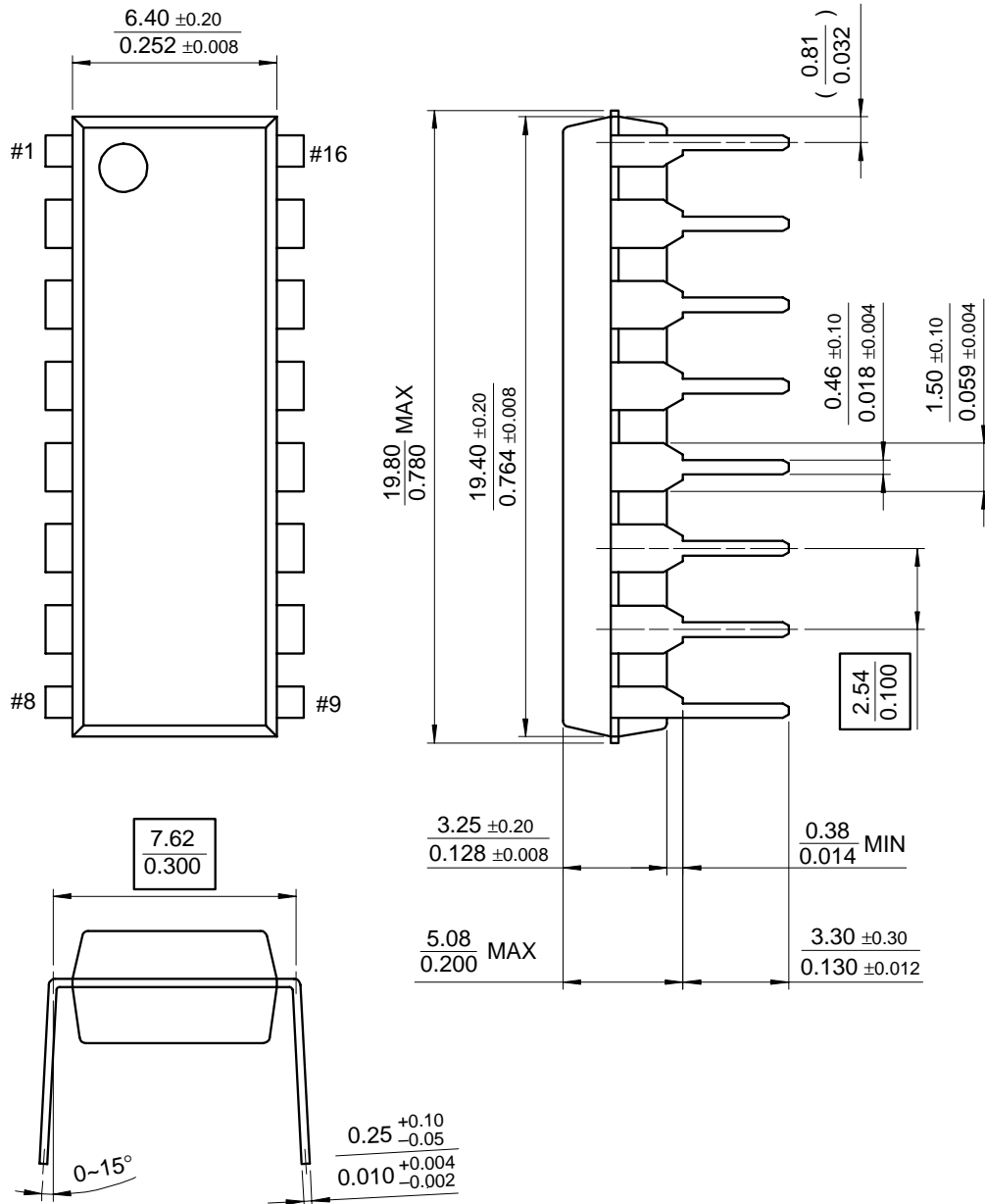



Mechanical Dimensions (Continued)

Package

16-SOP

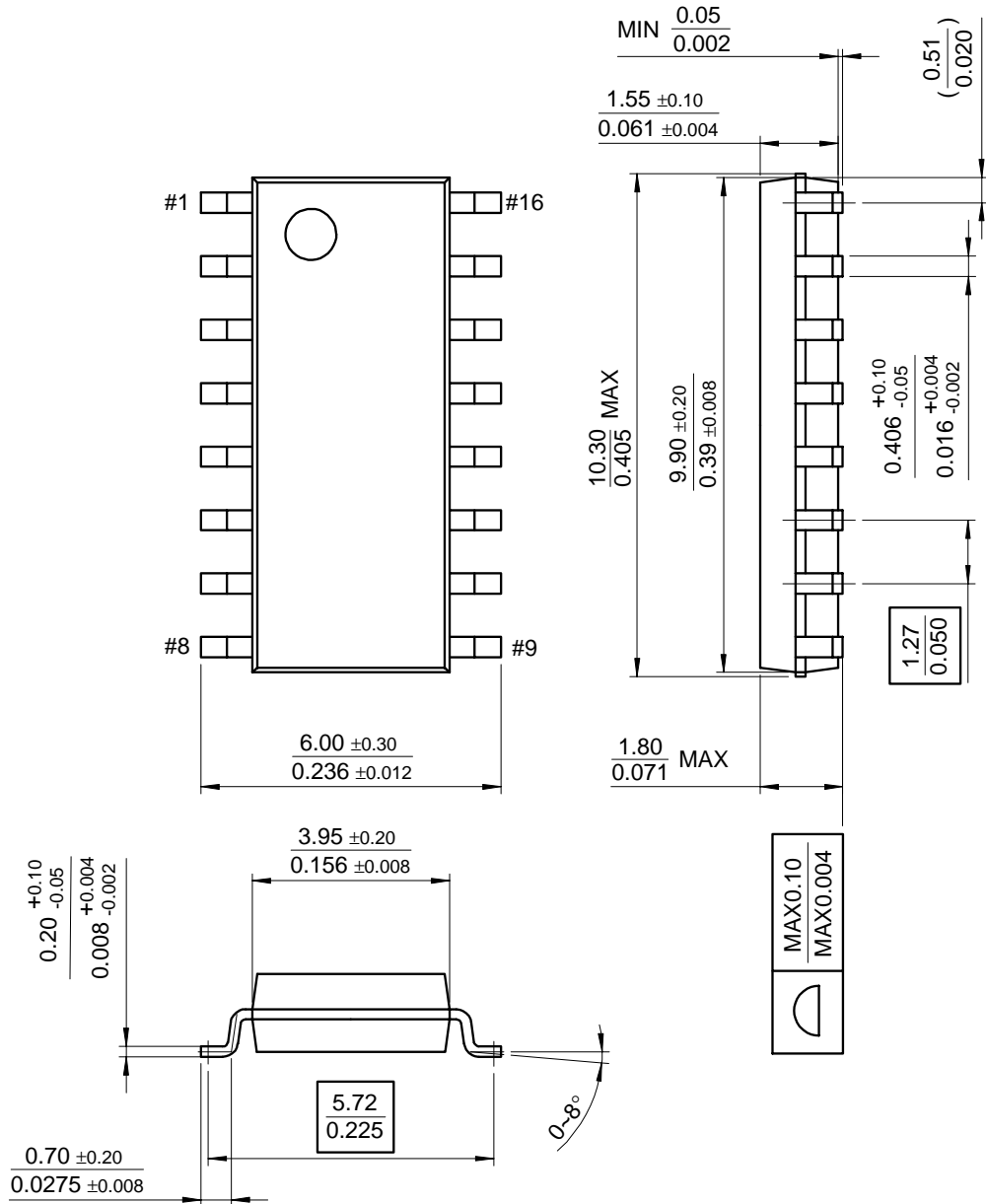



Ordering Information

Product Number	Package	Operating Temperature
AMS494CN	16 DIP	0 ~ + 70°C
AMS494CD	16 SOP	