

General Description

The ADT5115T/ADT5116TA is a transmitter IC for digital audio interface, e.g., DVD player, digital TV. This IC is packaged with LED in one fiber optic module. This supports the high speed data transmission near to 16Mbps and direct connections to modulation IC for digital audio equipment. The ADT5116T/ADT5116TA is very small to be suitable for any types of fiber transmitting module.

Features

- Low Jitter Output
- High Speed Data Transmission to 16Mbps
- Operating Voltage : 2.7V~5.5V
- Direct connectable to TTL or High Speed CMOS Logic
- LED Driving Current : ADT5116T(typ. 6mA), ADT5116TA(typ. 3mA)

Application

Fiber Optic Module for Digital Audio Equipment

Absolute Maximum Ratings (Ta=25°C)

Parameter	Symbol	Ratings	Unit
Supply Voltage	Vcc	-0.5 ~ 7.0	volts
Input Voltage	Vin	-0.5 ~ Vcc+0.5	volts
Operating Temperature	Topr	-20 ~ 70	°C
Storage Temperature	Tstg	-30 ~ 80	°C

* Stress above those listed under Absolute Maximum Ratings may cause permanent damage of device.

This is stress rating only and functional operation of the device at these or any other conditions above those indicated in the operational sections of this specification is not implied. Exposure to absolute maximum rating conditions for longer periods may affect device reliability.

During overload conditions (VIN>Vcc or VIN<GND), those voltage on Vcc pins with respect to ground must not exceed the values defined by the absolute maximum ratings.

Recommended Operating Conditions

Parameter	Symbol	Ratings	Unit
Operating Supply voltage	Vcc	2.7 ~ 5.5	volts
Transmitting Data Rate	Tdr	Max. 16.0	Mbps

* This specifications are subject to be changed without notice

Electrical Characteristics (Ta=25°C, Vcc=5.0V)

Parameter	Symbol	Condition	Min.	Typ.	Max.	Unit
Operating Current(ADT5116T)	I _{cc}	V _{in} =2.0V	7.5	8.0	8.5	mA
Operating Current(ADT5116TA)	I _{cc}	V _{in} =2.0V	5.0	5.5	6.0	mA
LED Driving Current(ADT5116T)	I _{LED}	V _{in} =2.0V	5.5	6.0	6.5	mA
LED Driving Current(ADT5116TA)	I _{LED}	V _{in} =2.0V	2.5	3.0	3.5	mA
Output High Level	V _{oh}	V _{in} =0.8V	4.8	-	-	volts
Output Low Level	V _{ol}	V _{in} =2.0V, R _{load} =220Ω	3.4	3.6	4.0	volts
Input High Level (ADT5116T)	V _{ih}	-	1.3	-	-	volts
Input High Level (ADT5116TA)	V _{ih}	-	1.1	-	-	volts
Input Low Level	V _{il}	-	-	-	0.8	volts
Propagation Delay Time(Low→High)	T _{plh}	f _{in} = 8MHz, NRZ	-	15	-	nsec
Propagation Delay Time(High→Low)	T _{phl}	f _{in} = 8MHz, NRZ	-	15	-	nsec

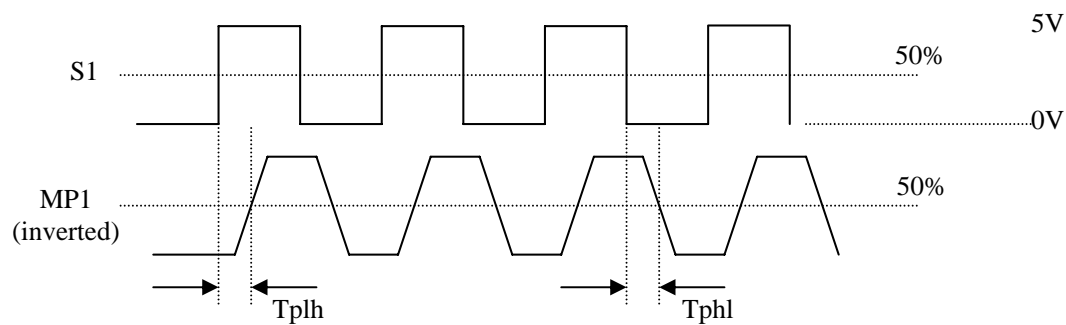
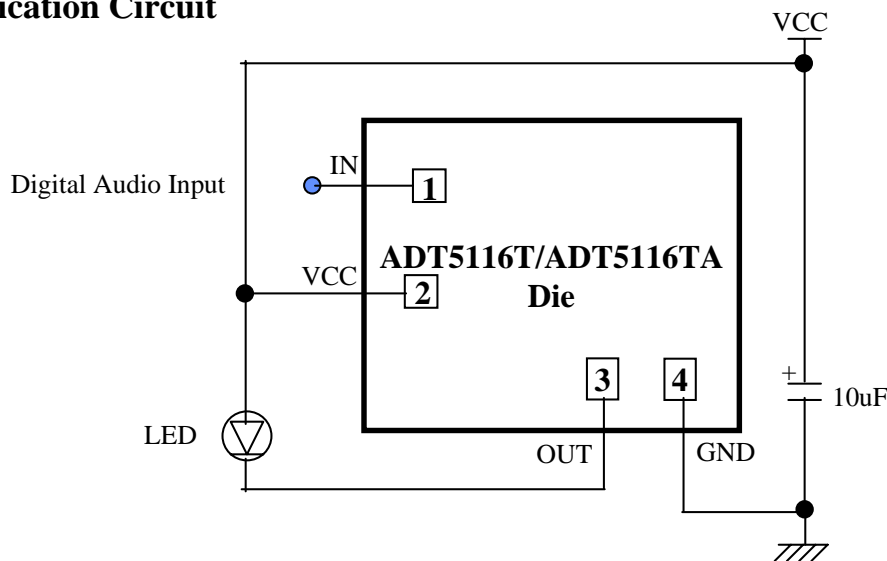
Input/Output Signal Description

Application Circuit

For the chip test, R_{load} is connected instead of LED.(R_{load}=220Ω)

** This specifications are subject to be changed without notice*