

### DESCRIPTION

The HY514400A is the 2nd generation and fast dynamic RAM organized 1,048,576 x 4-bit. The HY514400A utilizes Hyundai's CMOS silicon gate process technology as well as advanced circuit techniques to provide wide operating margins to the users. Multiplexed address inputs permit the HY514400A to be packaged in a standard 20/26 pin plastic SOJ, TSOP-II and Reverse TSOP-II.

The package size provides high system bit densities and is compatible with widely available automated testing and insertion equipments. System oriented feature includes single power supply of  $5V \pm 10\%$  tolerance and direct interfacing capability with high performance logic families such as Schottky TTL.

### FEATURES

- Low power dissipation
  - Max. battery back-up 2.2mW (L-part)
  - Max. CMOS standby 1.1mW (L-part)
  - 5.5mW
  - Max. TTL standby 11.0mW
  - Max. operating

Speed	Power
50	715.0mW
60	632.5mW
70	550.0mW

- Single power supply of  $5V \pm 10\%$
- TTL compatible inputs and outputs
- Fast access and cycle time

Speed	t <sub>RAC</sub>	t <sub>CAC</sub>	t <sub>PC</sub>
50	50ns	15ns	35ns
60	60ns	15ns	40ns
70	70ns	20ns	45ns

- Fast page mode operation
- Multi-bit test capability
- Read-Modify-Write capability
- CAS-before-RAS, RAS-only, Hidden refresh
- 1024 refresh cycles / 128ms (L-part)
- 1024 refresh cycles / 16ms

### PIN DESCRIPTION

RAS	Row Address Strobe
CAS	Column Address Strobe
WE	Write Enable
OE	Output Enable
A0-A9	Address Input
DQ0-DQ3	Data Input/Output
Vcc	Power (+5V)
Vss	Ground

### PIN CONNECTION

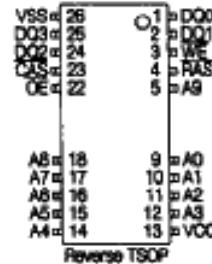
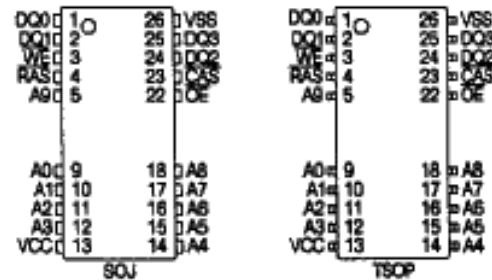

### BLOCK DIAGRAM

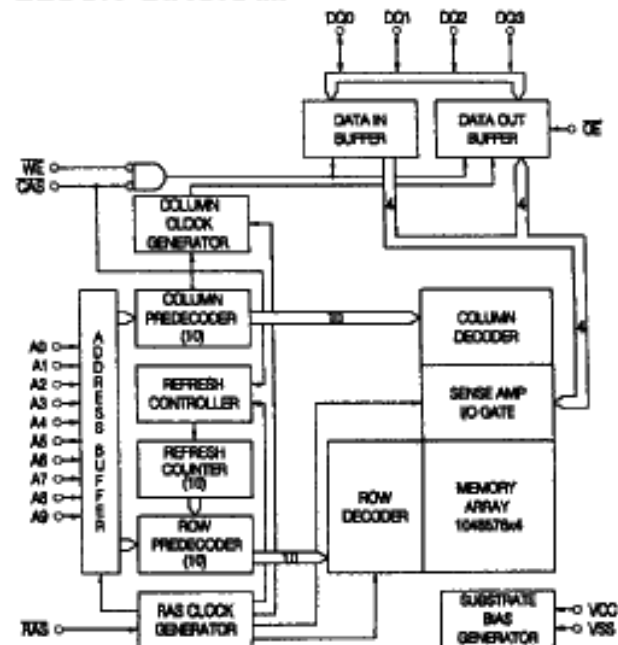

**ABSOLUTE MAXIMUM RATING**

SYMBOL	PARAMETER	RATING	UNIT
TA	Ambient Temperature	0 to 70	°C
TSTG	Storage Temperature	-55 to 150	°C
VIN, VOUT	Voltage on Any Pin Relative to Vss	-1.0 to 7.0	V
VCC	Voltage on VCC Relative to Vss	-1.0 to 7.0	V
IOS	Short Circuit Output Current	50	mA
Pd	Power Dissipation	0.90	W
TSOLDER	Soldering Temperature • Time	260 • 10	°C • sec

NOTE: Operation at or above Absolute Maximum Ratings can adversely affect device reliability.

**RECOMMENDED DC OPERATING CONDITIONS**

(TA = 0°C to 70°C)

SYMBOL	PARAMETER	MIN.	TYP.	MAX.	UNIT
VCC	Supply Voltage	4.5	5.0	5.5	V
VIH	Input High Voltage	2.4	-	Vcc+1.0	V
VIL	Input Low Voltage	-1.0	-	0.8	V

NOTE: All voltage are referenced to Vss.

**DC CHARACTERISTICS**

(TA=0°C to 70°C, Vcc=5.0V±10%, Vss=0V, unless otherwise noted.)

SYMBOL	PARAMETER	TEST CONDITIONS	SPEED/ POWER	MIN.	MAX.	UNIT	NOTE
I <sub>I</sub>	Input Leakage Current (Any Input Pins)	V <sub>ss</sub> ≤ V <sub>IN</sub> ≤ 6.5V All other pins not under test = V <sub>ss</sub>		-10	10	μA	
I <sub>LO</sub>	Output Leakage Current (High impedance State)	V <sub>ss</sub> ≤ V <sub>OUT</sub> ≤ 5.5V RAS & CAS at V <sub>IH</sub>		-10	10	μA	
I <sub>CC1</sub>	V <sub>cc</sub> Supply Current, Operating	trc = trc(min.)	50	-	130	mA	1,2,3
			60	-	115		
			70	-	100		
I <sub>CC2</sub>	V <sub>cc</sub> Supply Current, TTL Standby	RAS & CAS at V <sub>IH</sub> , other inputs ≥ V <sub>SS</sub>		-	2	mA	
I <sub>CC3</sub>	V <sub>cc</sub> Supply Current, RAS-only refresh	trc = trc(min.)	50	-	130	mA	1,3
			60	-	115		
			70	-	100		
I <sub>CC4</sub>	V <sub>cc</sub> Supply Current, Fast Page mode	tpc = tpc(min.)	50	-	80	mA	1,2,3
			60	-	70		
			70	-	60		
I <sub>CC5</sub>	V <sub>cc</sub> Supply Current, CMOS Standby	RAS & CAS ≥ V <sub>cc</sub> -0.2V	L-Part	-	1 0.2	mA	5
I <sub>CC6</sub>	V <sub>cc</sub> Supply Current, CAS-before- RAS refresh	trc = trc (min.)	50	-	130	mA	1,3
			60	-	115		
			70	-	100		
I <sub>CC7</sub>	V <sub>cc</sub> Supply Current, Battery Back up (L-part only)	trc = 125μs, CAS = CBR cycling or 0.2V OE & WE = V <sub>cc</sub> -0.2V, A0-A9 = V <sub>cc</sub> -0.2V or 0.2V DQ 0-DQ3 = 0.2V, V <sub>cc</sub> -0.2V or open	t <sub>RAS</sub> ≤ 300ns	-	300	μA	1,4,5
			t <sub>RAS</sub> ≤ 1μs	-	400		
V <sub>OL</sub>	Output Low Voltage	I <sub>OL</sub> = 4.2mA		-	0.4	V	
V <sub>OH</sub>	Output High Voltage	I <sub>OH</sub> = -5mA		2.4	-	V	

**NOTE :**

1. I<sub>CC1</sub>, I<sub>CC3</sub>, I<sub>CC4</sub>, I<sub>CC6</sub> and I<sub>CC7</sub> depend on cycle rate.
2. I<sub>CC1</sub>, I<sub>CC3</sub>, I<sub>CC4</sub> depend on output loading. Specified values are obtained with the output open.
3. It depends on user whether column address is changed or not at least once while RAS=V<sub>IL</sub> and CAS=V<sub>IH</sub>.
4. Only t<sub>RAS</sub>(max.) = 1μs is applied to refresh of battery backup but t<sub>RAS</sub>(max.) = 10μs is applied to normal functional operation .
5. I<sub>CC5</sub>(max.) = 0.2mA and I<sub>CC7</sub> are applied to L-parts only (HY514400ALJ, HY514400ALT and HY514400ALR).

**AC CHARACTERISTICS**

(TA=0°C to 70°C, Vcc=5V ± 10%, VSS=0V, unless otherwise noted.) NOTE1,2,3,13

#	SYMBOL	PARAMETER	HY514400AJ/AT/AR/ALJ/ALT/ALR						UNIT	NOTE
			- 50		- 60		- 70			
			MIN.	MAX.	MIN.	MAX.	MIN.	MAX.		
1	tRC	Random Read or Write Cycle Time	90	-	110	-	130	-	ns	
2	tRWC	Read-Modify-Write Cycle Time	130	-	150	-	180	-	ns	
3	tPC	Fast Page Mode Cycle Time	35	-	40	-	45	-	ns	
4	tPRWC	Fast Page Mode Read-Modify-Write Cycle Time	75	-	80	-	95	-	ns	
5	tRAC	Access Time from $\overline{\text{RAS}}$	-	50	-	60	-	70	ns	4,9,10
6	tCAC	Access Time from $\overline{\text{CAS}}$	-	15	-	15	-	20	ns	4,9
7	tAA	Access Time from Column Address	-	25	-	30	-	35	ns	4,10
8	tCPA	Access Time from $\overline{\text{CAS}}$ Precharge	-	30	-	35	-	40	ns	4,15
9	tCLZ	$\overline{\text{CAS}}$ to Output Low Impedance	0	-	0	-	0	-	ns	4
10	tOFF	Output Buffer Turn-off Delay	0	15	0	15	0	20	ns	5
11	tT	Transition Time (Rise and Fall)	3	50	3	50	3	50	ns	3
12	tRP	$\overline{\text{RAS}}$ Precharge Time	30	-	40	-	50	-	ns	
13	tRAS	$\overline{\text{RAS}}$ Pulse Width	50	10K	60	10K	70	10K	ns	
14	tRASP	$\overline{\text{RAS}}$ Pulse Width (Fast Page Mode)	50	200K	60	200K	70	200K	ns	
15	tRSH	$\overline{\text{RAS}}$ Hold Time	15	-	15	-	20	-	ns	
16	tCSH	$\overline{\text{CAS}}$ Hold Time	50	-	60	-	70	-	ns	
17	tCAS	$\overline{\text{CAS}}$ Pulse width	15	10K	15	10K	20	10K	ns	
18	tRCD	$\overline{\text{RAS}}$ to $\overline{\text{CAS}}$ Delay	15	35	20	45	20	50	ns	9
19	tRAD	$\overline{\text{RAS}}$ to Column Address Delay Time	10	25	15	30	15	35	ns	10
20	tCRP	$\overline{\text{CAS}}$ to $\overline{\text{RAS}}$ Precharge Time	5	-	5	-	5	-	ns	15
21	tCP	$\overline{\text{CAS}}$ Precharge Time	10	-	10	-	10	-	ns	17
22	tASR	Row Address Set-up Time	0	-	0	-	0	-	ns	
23	tRAH	Row Address Hold time	8	-	10	-	10	-	ns	
24	tASC	Column Address Set-up Time	0	-	0	-	0	-	ns	14
25	tCAH	Column Address Hold Time	15	-	15	-	15	-	ns	14
26	tAR	Column Address Hold Time from $\overline{\text{RAS}}$	45	-	50	-	55	-	ns	
27	tRAL	Column Address to $\overline{\text{RAS}}$ Lead Time	25	-	30	-	35	-	ns	
28	tRCS	Read Command Set-up Time	0	-	0	-	0	-	ns	14
29	tRCH	Read Command Hold Time Referenced to $\overline{\text{CAS}}$	0	-	0	-	0	-	ns	6,14
30	tRRH	Read Command Hold Time Referenced to $\overline{\text{RAS}}$	0	-	0	-	0	-	ns	6
31	tWCH	Write Command Hold Time	10	-	15	-	15	-	ns	14
32	tWCR	Write Command Hold Time from $\overline{\text{RAS}}$	40	-	50	-	55	-	ns	
33	tWP	Write Command Pulse Width	10	-	15	-	15	-	ns	
34	tRWL	Write Command to $\overline{\text{RAS}}$ Lead Time	15	-	15	-	20	-	ns	
35	tCWL	Write Command to $\overline{\text{CAS}}$ Lead Time	15	-	15	-	20	-	ns	16
36	tDS	Data-In Set-up Time	0	-	0	-	0	-	ns	7
37	tDH	Data-In Hold Time	10	-	15	-	15	-	ns	7
38	tDHR	Data-In Hold Time Referenced to $\overline{\text{RAS}}$	40	-	50	-	55	-	ns	
39	tREF	Refresh Period (1024 cycles)	-	16	-	16	-	16	ms	12
		L-part	-	128	-	128	-	128	ms	11
40	tWCS	Write Command Set up Time	0	-	0	-	0	-	ns	8,14

**AC CHARACTERISTICS**

(continued)

#	SYMBOL	PARAMETER	HY514400AJ/AT/AR/ALJ/ALT/ALR						UNIT	NOTE
			- 50		- 60		- 70			
			MIN.	MAX.	MIN.	MAX.	MIN.	MAX.		
41	tCWD	CAS to WE Delay Time	35	-	35	-	40	-	ns	8
42	tRWD	RAS to WE Delay Time	70	-	80	-	95	-	ns	8
43	tAWD	Column Address to WE Delay Time	45	-	50	-	60	-	ns	8
44	tCSR	CAS Set-up Time (CBR Cycle)	5	-	5	-	5	-	ns	14
45	tCHR	CAS Hold Time (CBR Cycle)	10	-	10	-	10	-	ns	15
46	tRPC	RAS to CAS Precharge Time	5	-	5	-	5	-	ns	14
47	tCPT	CAS Precharge Time (CBR Counter Test)	25	-	30	-	35	-	ns	17
48	tROH	RAS Hold Time Referenced to OE	10	-	10	-	10	20	ns	
49	tOEA	OE Access Time	-	15	-	15	-	20	ns	
50	tOED	OE to Data Delay	15	-	15	-	20	-	ns	
51	tOEZ	Output Buffer Turn Off Delay Time from OE	0	15	0	15	0	20	ns	5
52	tOEH	OE Command Hold Time	15	-	15	-	20	-	ns	
53	tCPWD	WE Delay time from CAS Precharge	50	-	55	-	65	-	ns	8
54	tRHCP	RAS Hold Time from CAS Precharge	30	-	35	-	40	-	ns	
55	tWRP	WE to RAS Precharge Time (CBR Cycle)	10	-	10	-	10	-	ns	
56	tWRH	WE to RAS Hold Time (CBR Cycle)	10	-	10	-	10	-	ns	
57	tWTS	Write Command Set-up Time (Test Mode In)	10	-	10	-	10	-	ns	
58	tWTH	Write Command Hold Time (Test Mode In)	10	-	10	-	10	-	ns	

4675088 0004159 934

**AC CHARACTERISTICS IN TEST MODE** NOTE 18

#	SYMBOL	PARAMETER	HY514400AJ/AT/AR/ALJ/ALT/ALR						UNIT	NOTE
			- 50		- 60		- 70			
			MIN.	MAX.	MIN.	MAX.	MIN.	MAX.		
1	t <sub>RC</sub>	Random Read or Write Cycle Time	95	-	115	-	135	-	ns	
2	t <sub>RWC</sub>	Read-Modify-Write Cycle Time	135	-	155	-	185	-	ns	
3	t <sub>PC</sub>	Fast Page Mode Cycle Time	40	-	45	-	50	-	ns	
4	t <sub>PRWC</sub>	Fast Page Mode Read-Modify-Write Cycle Time	80	-	85	-	100	-	ns	
5	t <sub>RAC</sub>	Access Time from $\overline{\text{RAS}}$	-	55	-	65	-	75	ns	4,9,10
6	t <sub>CAC</sub>	Access Time from $\overline{\text{CAS}}$	-	20	-	20	-	25	ns	4,9
7	t <sub>AA</sub>	Access Time from Column Address	-	30	-	35	-	40	ns	4,10
8	t <sub>CPA</sub>	Access Time from $\overline{\text{CAS}}$ Precharge	-	35	-	40	-	45	ns	4
13	t <sub>RAS</sub>	$\overline{\text{RAS}}$ Pulse Width	55	10K	65	10K	75	10K	ns	
14	t <sub>RASP</sub>	$\overline{\text{RAS}}$ Pulse Width (Fast Page Mode)	55	200K	65	200K	75	200K	ns	
15	t <sub>RS</sub>	$\overline{\text{RAS}}$ Hold Time	20	-	20	-	25	-	ns	
16	t <sub>CS</sub>	$\overline{\text{CAS}}$ Hold Time	55	-	65	-	75	-	ns	
17	t <sub>CAS</sub>	$\overline{\text{CAS}}$ Pulse Width	20	10K	20	10K	25	10K	ns	
27	t <sub>RAL</sub>	Column Address to $\overline{\text{RAS}}$ Lead Time	30	-	35	-	40	-	ns	
41	t <sub>CWD</sub>	$\overline{\text{CAS}}$ to $\overline{\text{WE}}$ Delay Time	40	-	40	-	50	-	ns	8
42	t <sub>RWD</sub>	$\overline{\text{RAS}}$ to $\overline{\text{WE}}$ Delay Time	75	-	85	-	100	-	ns	8
43	t <sub>AWD</sub>	Column Address to $\overline{\text{WE}}$ Delay Time	50	-	55	-	65	-	ns	8
49	t <sub>OE</sub>	$\overline{\text{OE}}$ Access Time	-	20	-	20	-	25	ns	
50	t <sub>OED</sub>	$\overline{\text{OE}}$ to Data Delay	20	-	20	-	25	-	ns	
52	t <sub>OEH</sub>	$\overline{\text{OE}}$ Command Hold Time	20	-	20	-	25	-	ns	

4675088 0004160 656

**NOTE:**

1. An initial pause of 200µs is required after power-up followed by any 8  $\overline{\text{RAS}}$ -only or  $\overline{\text{CAS}}$ -before- $\overline{\text{RAS}}$  refresh cycles before proper device operation is achieved.
2. If  $\overline{\text{RAS}}=V_{\text{ss}}$  during power-up, the HY514400A could begin an active cycle. These condition results in higher current than necessary current which is demanded from the power supply during power-up. It is recommended that  $\overline{\text{RAS}}$  and  $\overline{\text{CAS}}$  track with  $V_{\text{cc}}$  during power-up or be held at a valid  $V_{\text{IH}}$  in order to minimize the power-up current
3.  $V_{\text{IH}}(\text{min.})$  and  $V_{\text{IL}}(\text{max.})$  are reference levels for measuring timing of input signals. Also, transition times are measured between  $V_{\text{IH}}(\text{min.})$  and  $V_{\text{IL}}(\text{max.})$ , and are assumed to be 5ns for all inputs.
4. Measured at  $V_{\text{OH}}=2.4\text{V}$  and  $V_{\text{OL}}=0.4\text{V}$  with a load equivalent to 2 TTL loads and 100pF.
5.  $t_{\text{OFF}}(\text{max.})$  define the time at which the output achieves the open circuit condition and is not referenced to output voltage levels.
6. Either  $t_{\text{RCH}}$  or  $t_{\text{RRH}}$  must be satisfied for a read cycle.
7. These parameters are referenced to  $\overline{\text{CAS}}$  leading edge in early write cycles and to  $\overline{\text{WE}}$  leading edge in Read-Modify-Write cycles.
8.  $t_{\text{WCS}}$ ,  $t_{\text{RWD}}$ ,  $t_{\text{CWD}}$ ,  $t_{\text{AWD}}$  and  $t_{\text{CPWD}}$  are not restrictive operating parameters. They are included in the data sheet as electrical characteristics only. If  $t_{\text{WCS}} \geq t_{\text{WCS}}(\text{min.})$ , the cycle is an early write cycle and data out pin will remain open circuit (high impedance) through the entire cycle. if  $t_{\text{RWD}} \geq t_{\text{RWD}}(\text{min.})$ ,  $t_{\text{CWD}} \geq t_{\text{CWD}}(\text{min.})$ ,  $t_{\text{AWD}} \geq t_{\text{AWD}}(\text{min.})$ , and  $t_{\text{CPWD}} \geq t_{\text{CPWD}}(\text{min.})$ , the cycle is a Read-Modify-Write cycle and data out will contain data read from the selected cell. If neither of the above sets of conditions is satisfied, the condition of the data out (at access time) is indeterminated.
9. Operation within the  $t_{\text{RCD}}(\text{max.})$  limit insures that  $t_{\text{RAC}}(\text{max.})$  can be met.  $t_{\text{RCD}}(\text{max.})$  is specified as a reference point only. If  $t_{\text{RCD}}$  is greater than the specified  $t_{\text{RCD}}(\text{max.})$  limit, then access time is controlled by  $t_{\text{CAC}}$ .
10. Operation within the  $t_{\text{RAD}}(\text{max.})$  limit insures that  $t_{\text{RAC}}(\text{max.})$  can be met.  $t_{\text{RAD}}(\text{max.})$  is specified as a reference point only. If  $t_{\text{RAD}}$  is greater than the specified  $t_{\text{RAD}}(\text{max.})$  limit, then access time is controlled by  $t_{\text{AA}}$ .
11.  $t_{\text{REF}}(\text{max.})=128\text{ms}$  is applied to L-Parts(HY514400ALJ, HY514400ALT and HY514400ALR).
12. A burst of 1024  $\overline{\text{CAS}}$ -before- $\overline{\text{RAS}}$  refresh cycles must be executed within 16ms(128ms for L-part) after exiting self refresh.
13. When  $\overline{\text{CAS}}$  goes low, 4-bits data are written into the device.
14. These parameters are determined by the earlier falling edge of  $\overline{\text{CAS}}$ .
15. These parameters are determined by the later rising edge of  $\overline{\text{CAS}}$ .
16.  $t_{\text{CWL}}$  must be satisfied by  $\overline{\text{CAS}}$  for 16-bits access cycles.
17.  $t_{\text{CP}}$  and  $t_{\text{CPT}}$  are measured when  $\overline{\text{CAS}}$  is high state.
18. These specificaitons are applied to the test Mode.

**CAPACITANCE**

( $T_{\text{A}}=25^{\circ}\text{C}$ ,  $V_{\text{cc}}=5\text{V} \pm 10\%$ ,  $V_{\text{ss}}=0\text{V}$ ,  $f=1\text{MHz}$ , unless otherwise noted.)

SYMBOL	PARAMETER	TYP.	MAX.	UNIT
CIN1	Input Capacitance (A0-A9)	-	5	pF
CIN2	Input Capacitance ( $\overline{\text{RAS}}$ , $\overline{\text{CAS}}$ , $\overline{\text{WE}}$ , $\overline{\text{OE}}$ )	-	7	pF
CDQ	Data Input/Output Capacitance (DQ0-DQ3)	-	7	pF

4675088 0004161 592

TIMING DIAGRAM

READ CYCLE

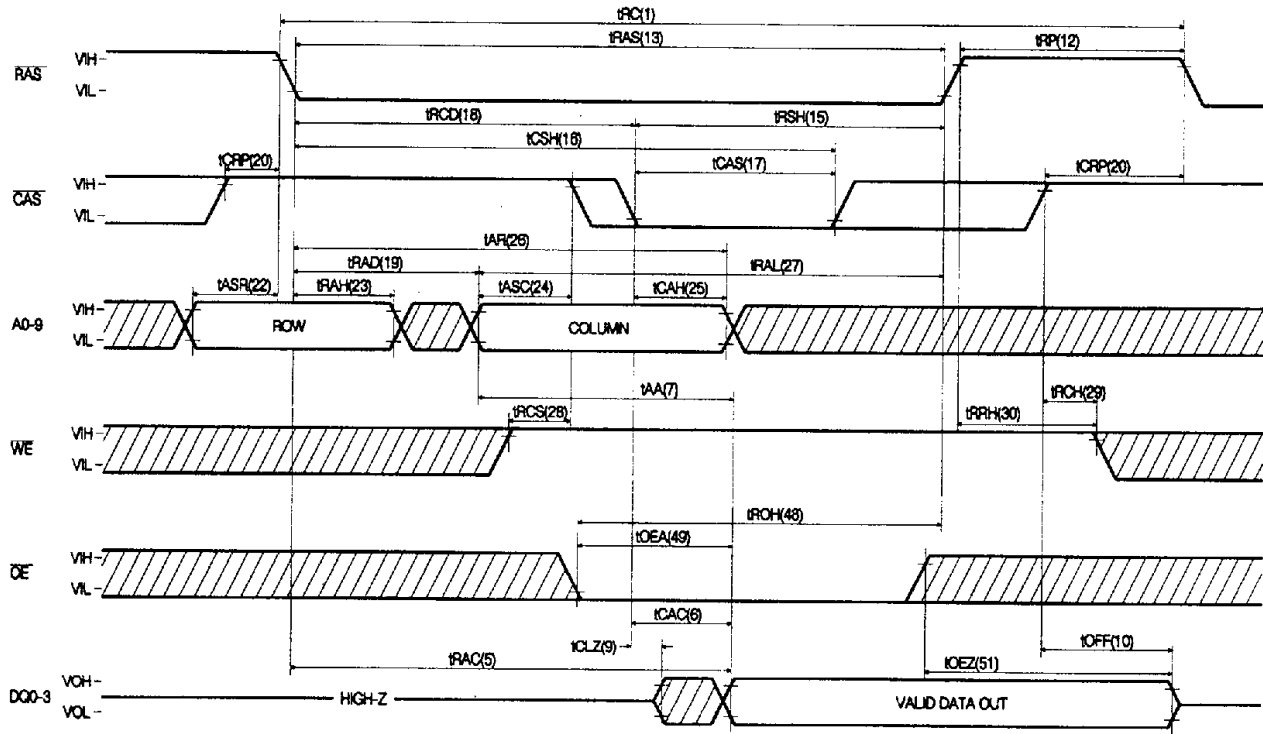

EARLY WRITE CYCLE

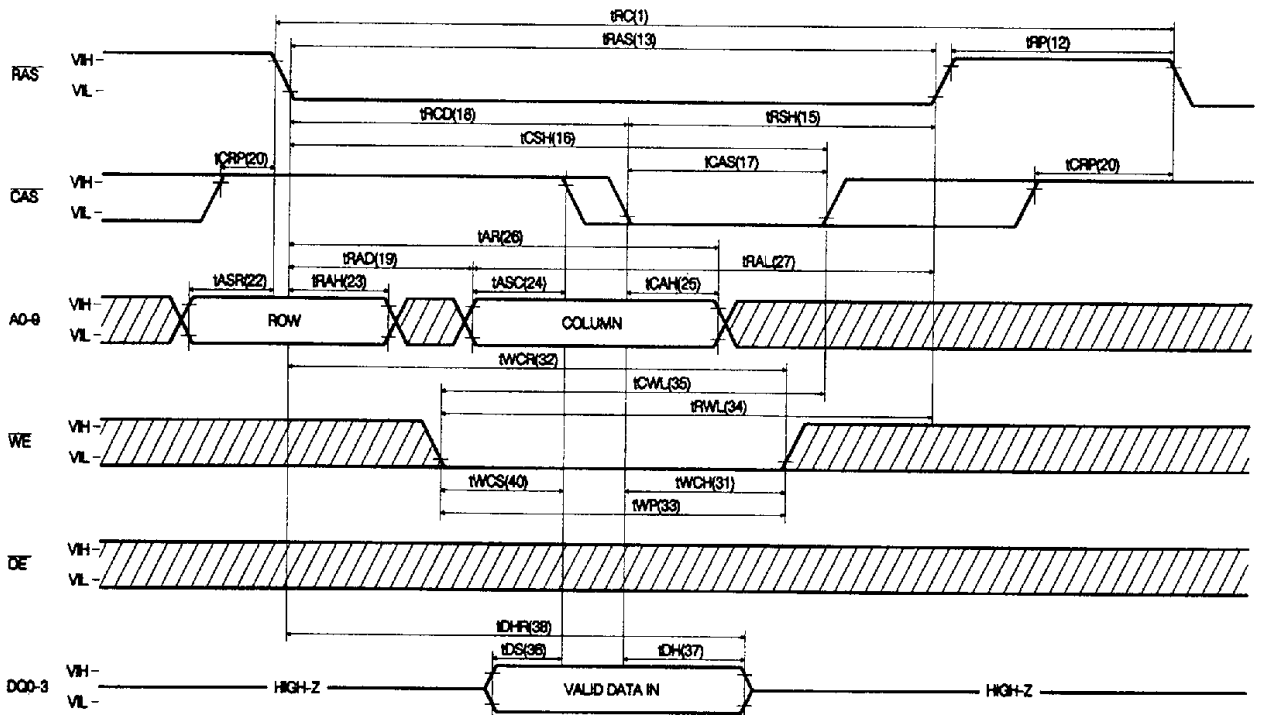

4675088 0004J62 429



**WRITE CYCLE ( $\overline{OE}$  CONTROLLED WRITE)**

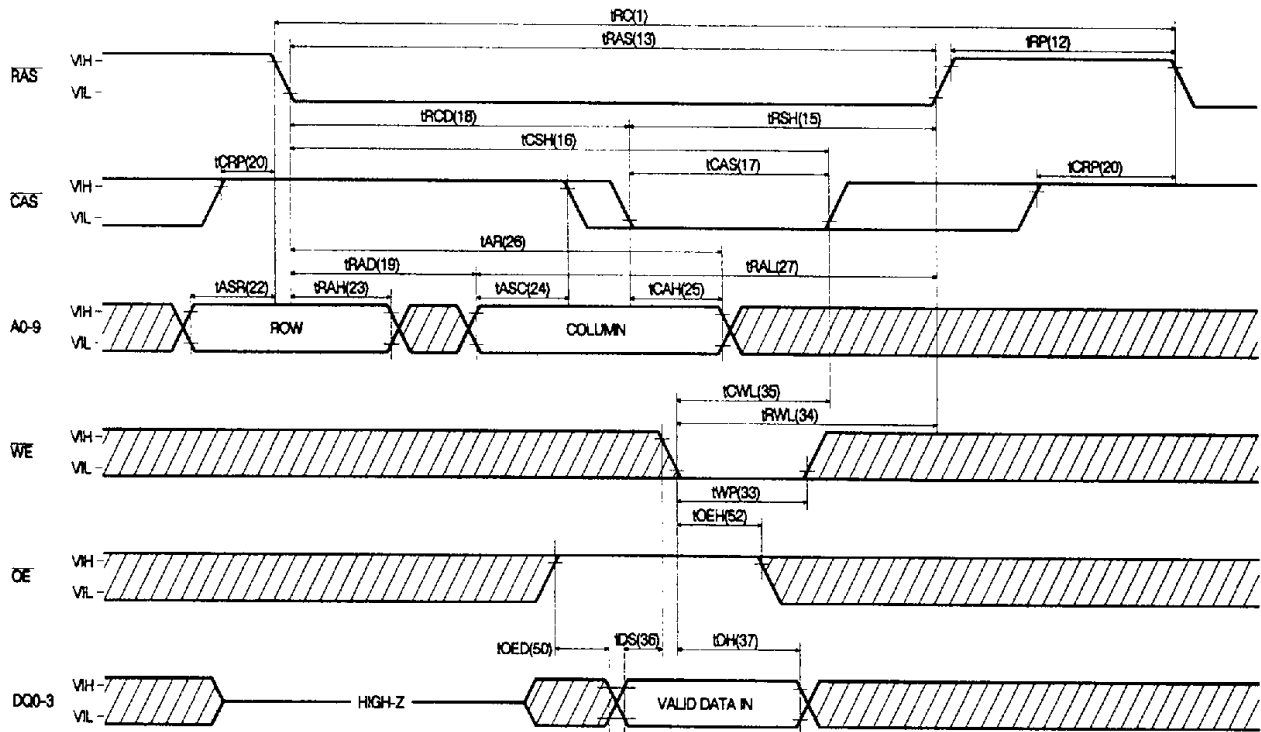

**READ-MODIFY-WRITE CYCLE**

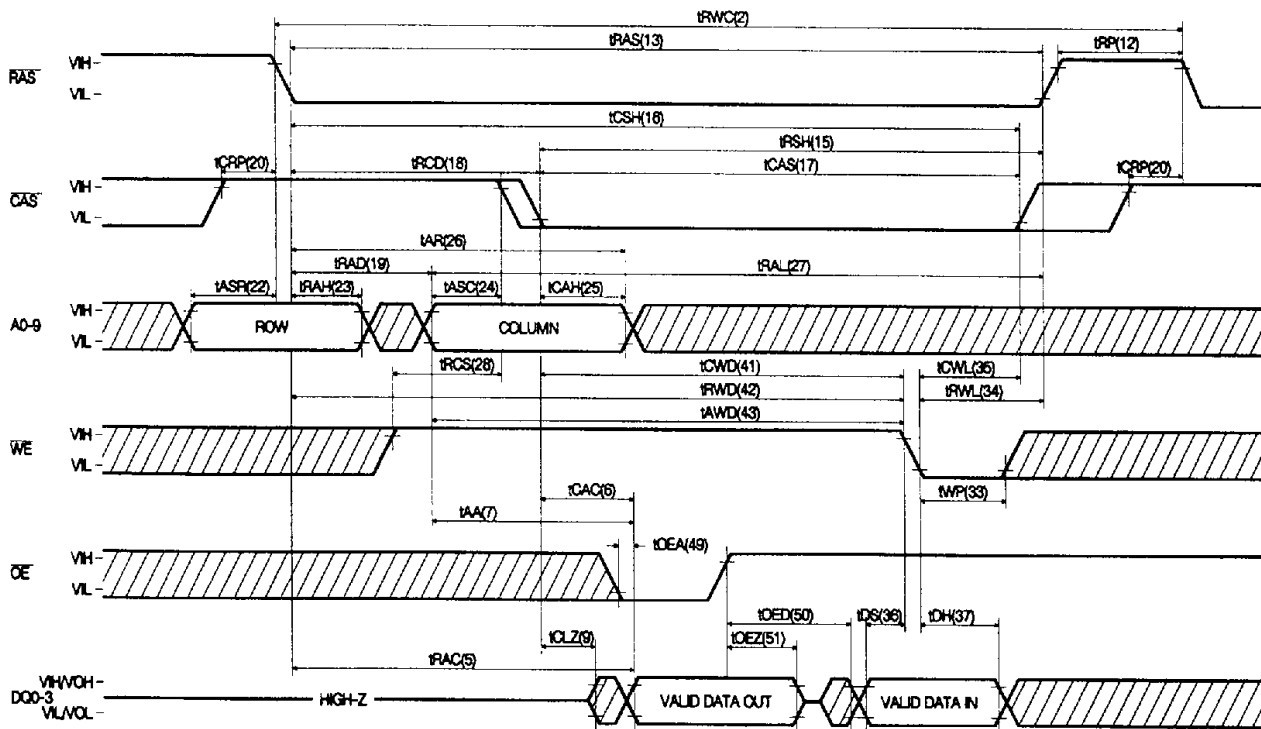

4675088 0004163 365

FAST PAGE MODE READ CYCLE

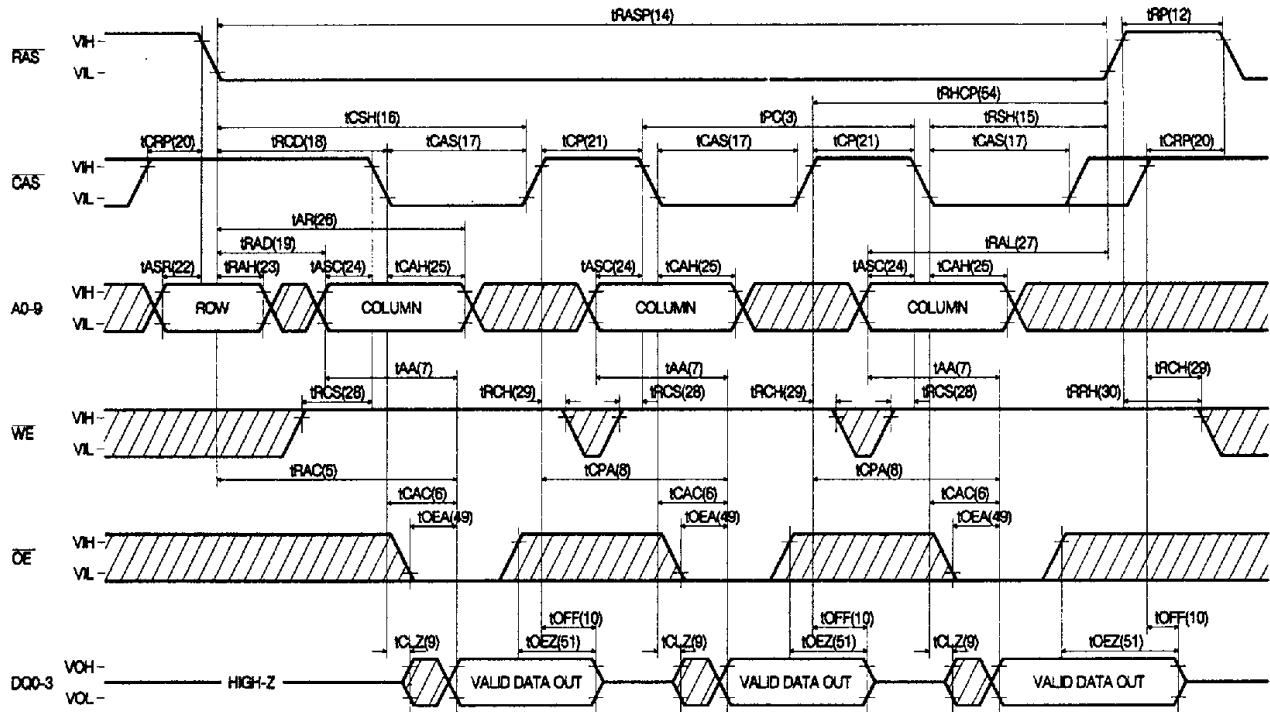

FAST PAGE MODE EARLY WRITE CYCLE

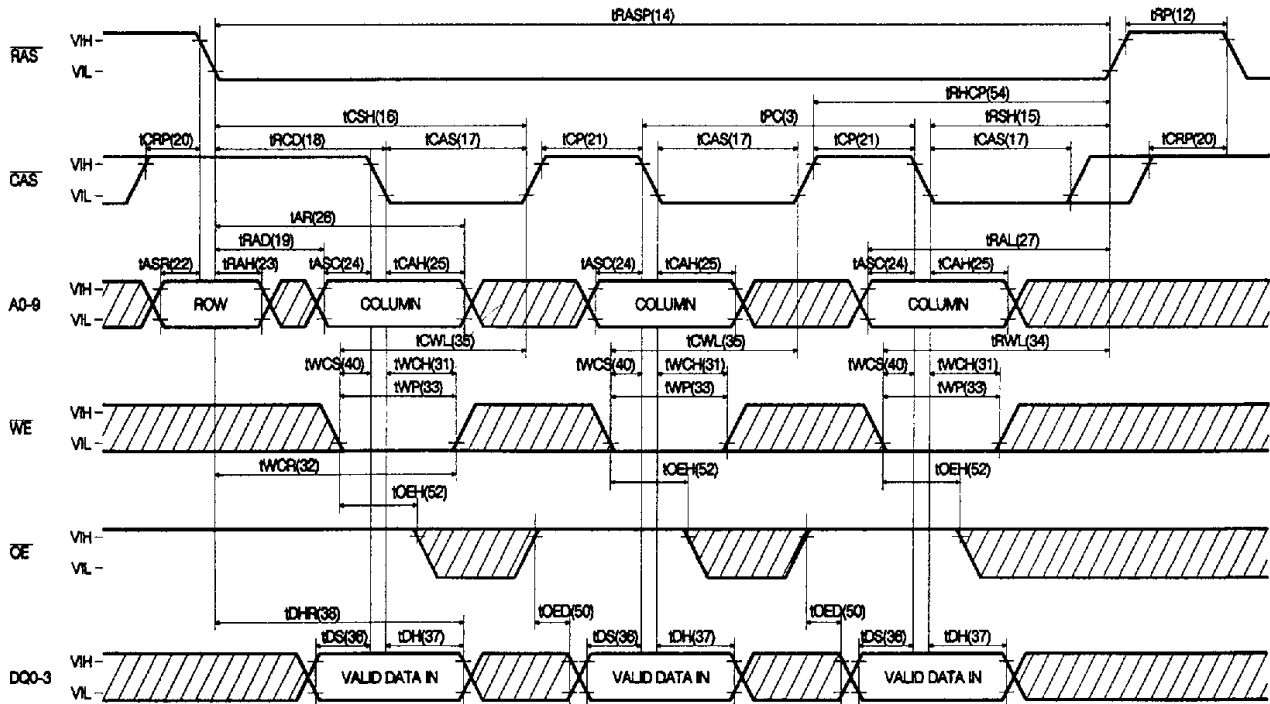

4675088 0004164 2T1

FAST PAGE MODE READ-MODIFY-WRITE CYCLE

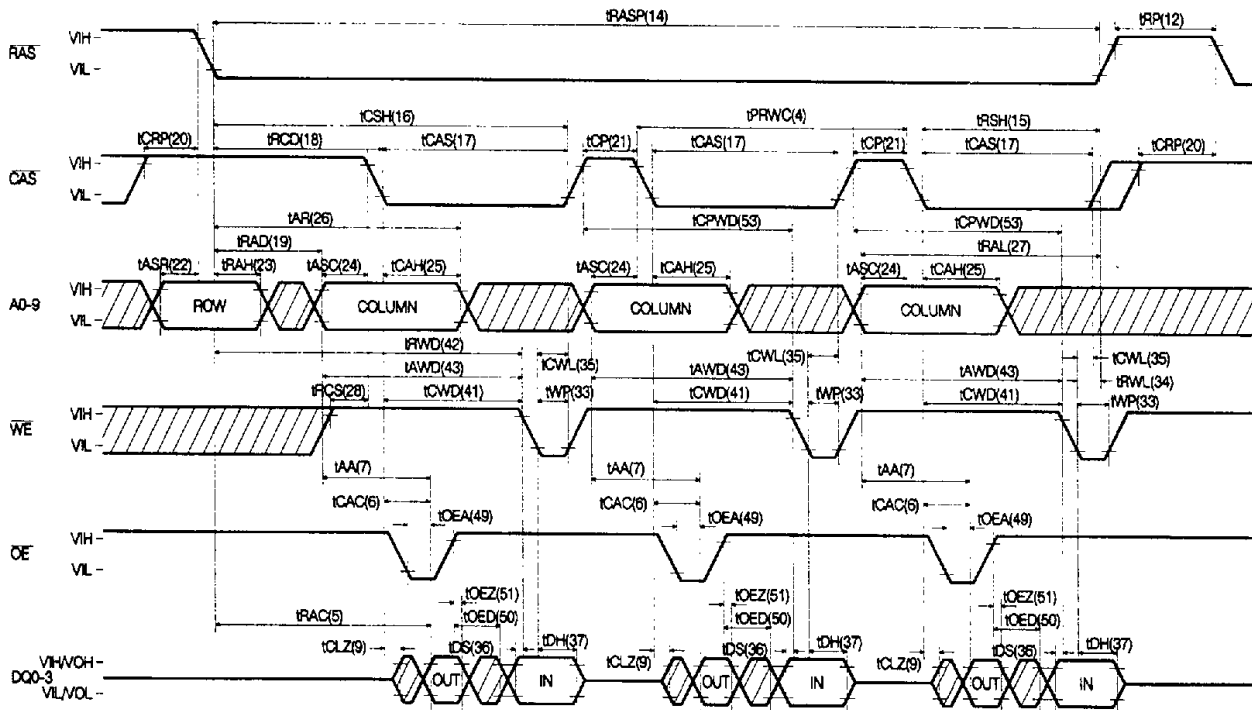

RAS-ONLY REFRESH CYCLE

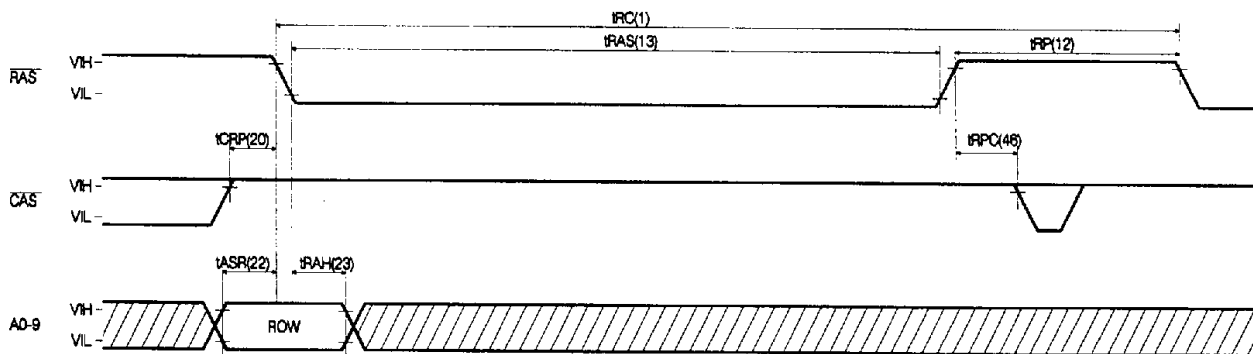

NOTE: A0-10 = "H" or "L"

**CAS-BEFORE-RAS REFRESH CYCLE**

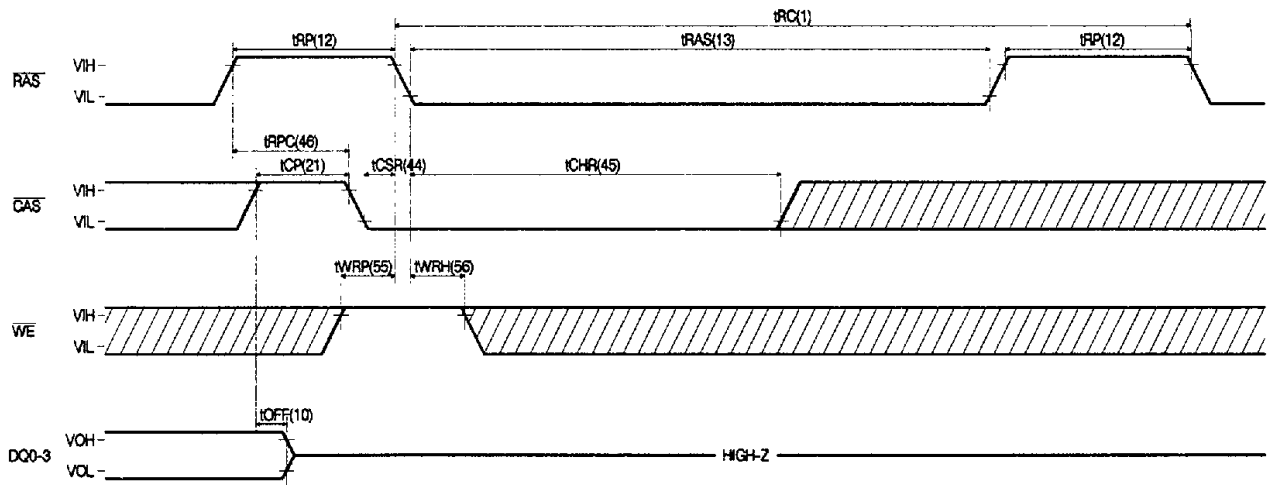

NOTE:A0-9 and  $\overline{OE}$ ="H" or "L"

**HIDDEN REFRESH CYCLE (READ)**

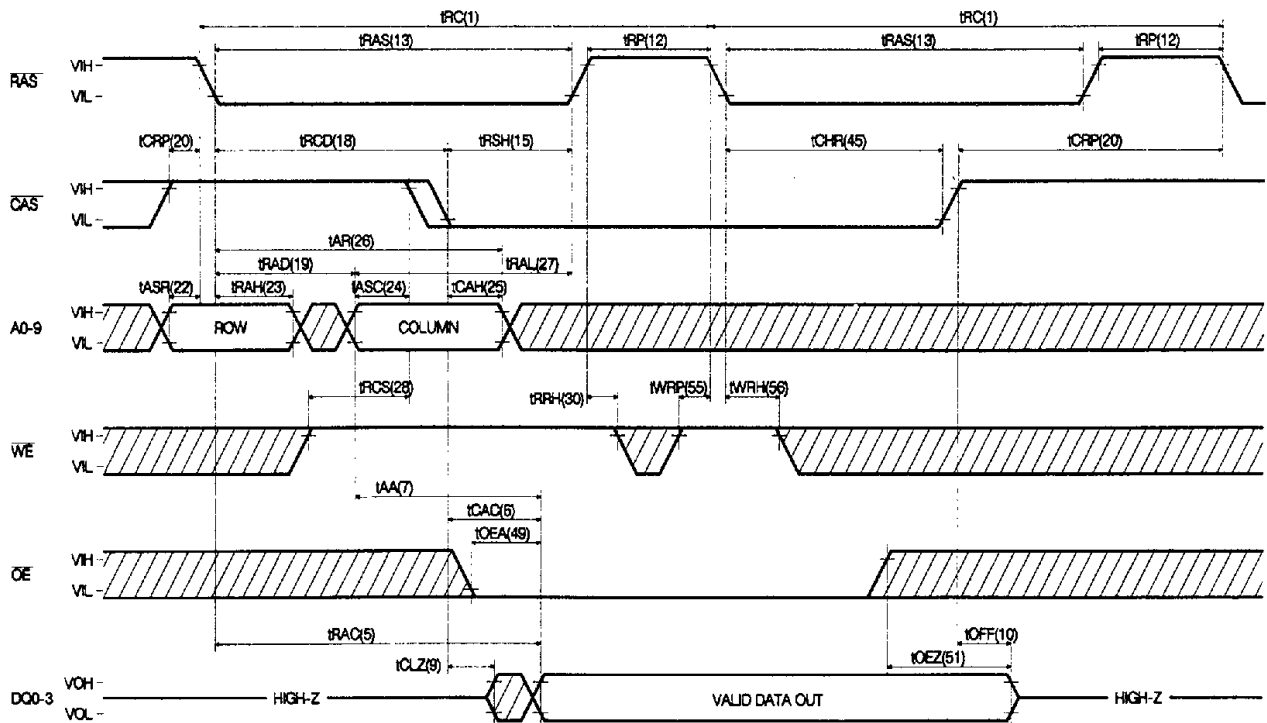

**HIDDEN REFRESH CYCLE (WRITE)**

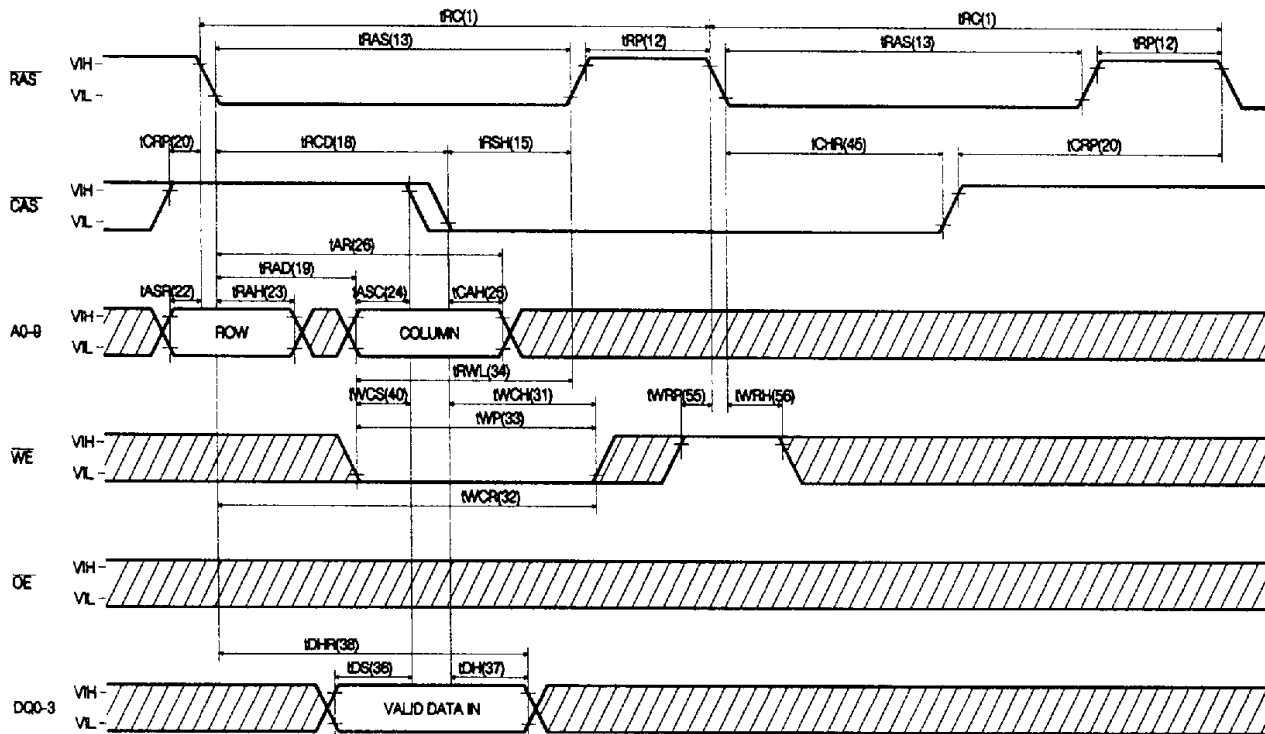

4675088 0004167 T00

**CAS-BEFORE-RAS REFRESH COUNTER TEST CYCLE**

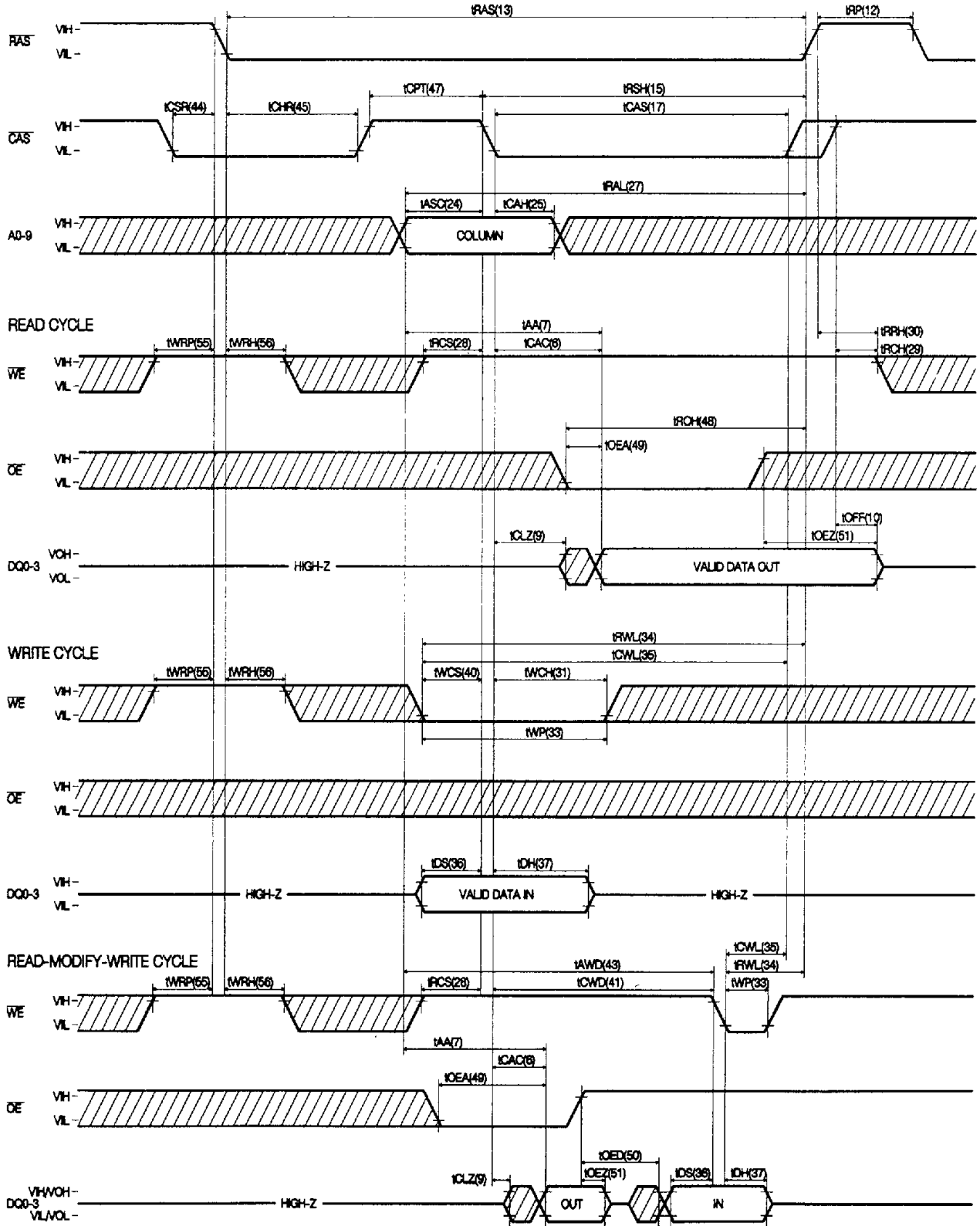

4675088 0004168 947

**TEST MODE**

The HY514400A is a DRAM organized 1,048,576 x 4-bit. It is internally organized 524,288 x 8-bit. In Test Mode, data are written into 8 sectors (Each is composed of 512K bits) in parallel and retrieved the same way. Column address A0 is not used. If, upon reading, all 8-bit data from 8 sectors are equal (all "1"s or "0"s), the DQ2 pin indicates a "1". If they are not equal, the DQ2 pin indicates a "0". The DQ0, DQ1 and DQ3 pins always indicate a "1" in Test Mode Read cycles. The diagram below shows the timing of the HY514400A to enter Test Mode. In Test Mode, the 1Mx4 DRAM can be tested as if it were a 512Kx4 DRAM. WE, CAS-before-RAS cycle (Test Mode In Cycle) puts the HY514400A into Test Mode and CAS-before-RAS or RAS-only refresh cycle puts it back into Normal Mode. In Test Mode, WE, CAS-before-RAS cycle shall be used for the refresh operation. The Test Mode function reduces test time. (1/2 in case of N test pattern)

**TEST MODE IN CYCLE**

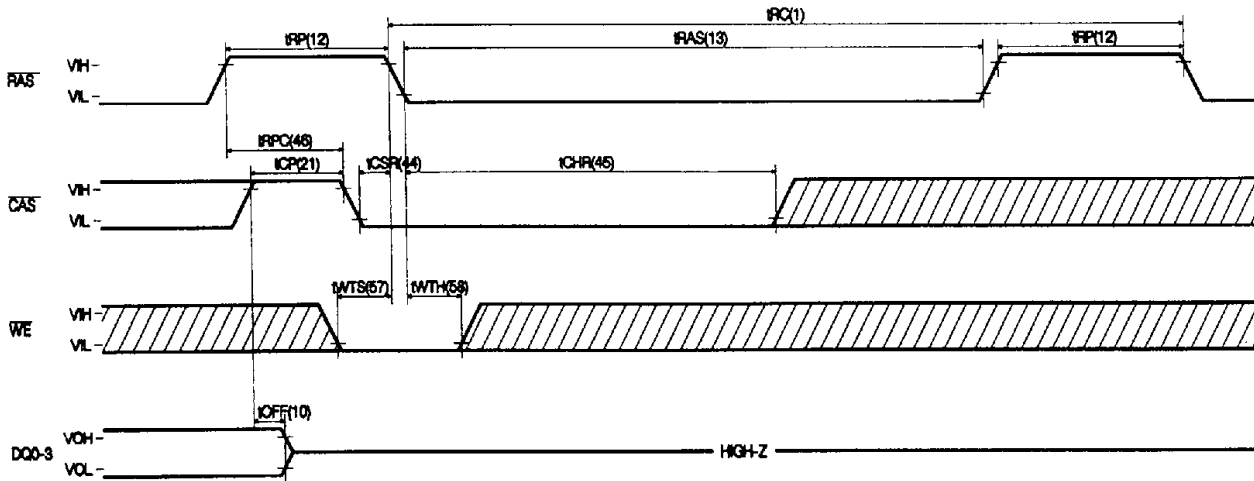

BLOCK DIAGRAM IN TEST MODE

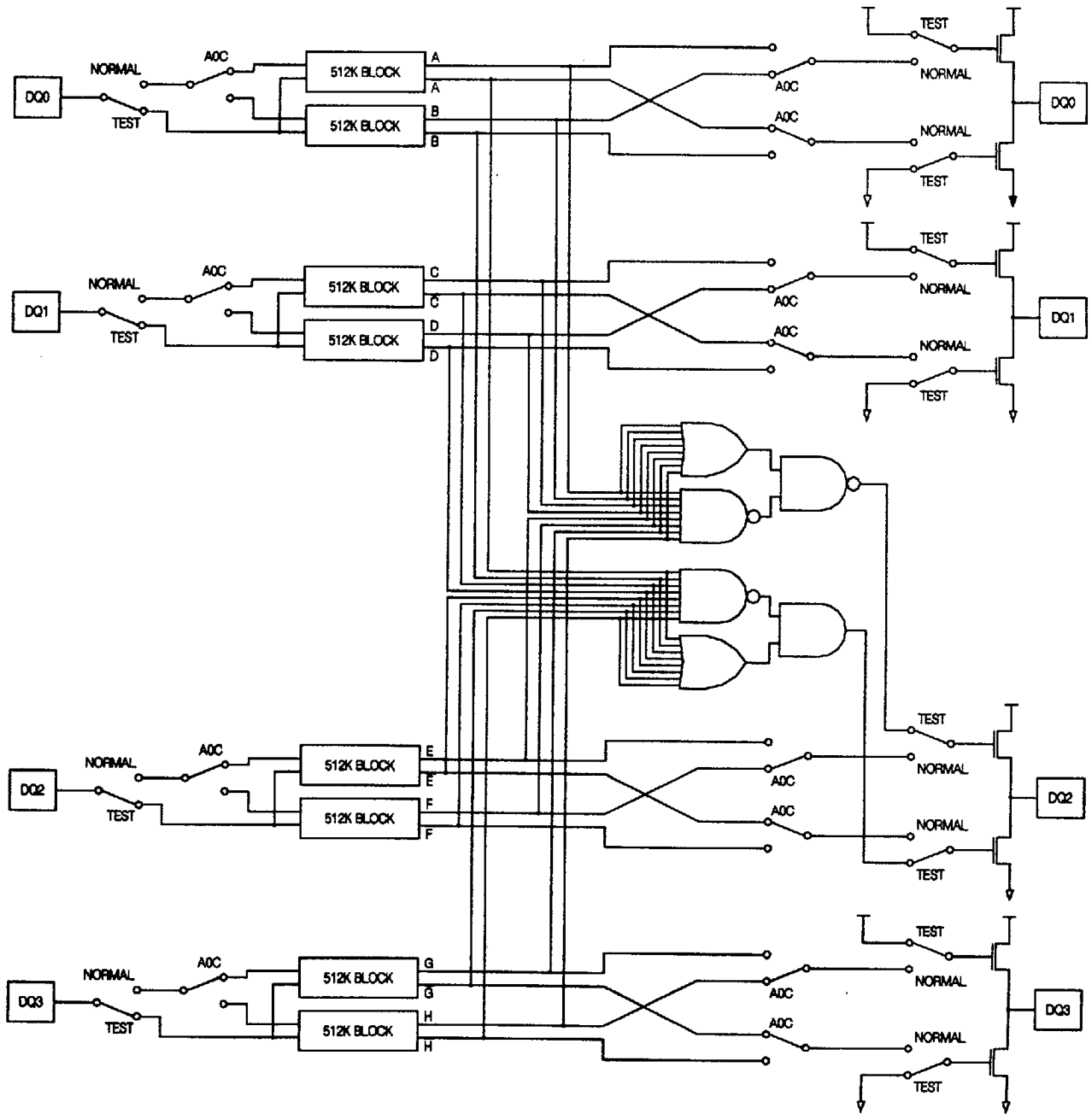

4675088 0004170 5T5



**PACKAGE INFORMATION**

**300 mil 20/26 pin Small Out line J-form Package (J)**

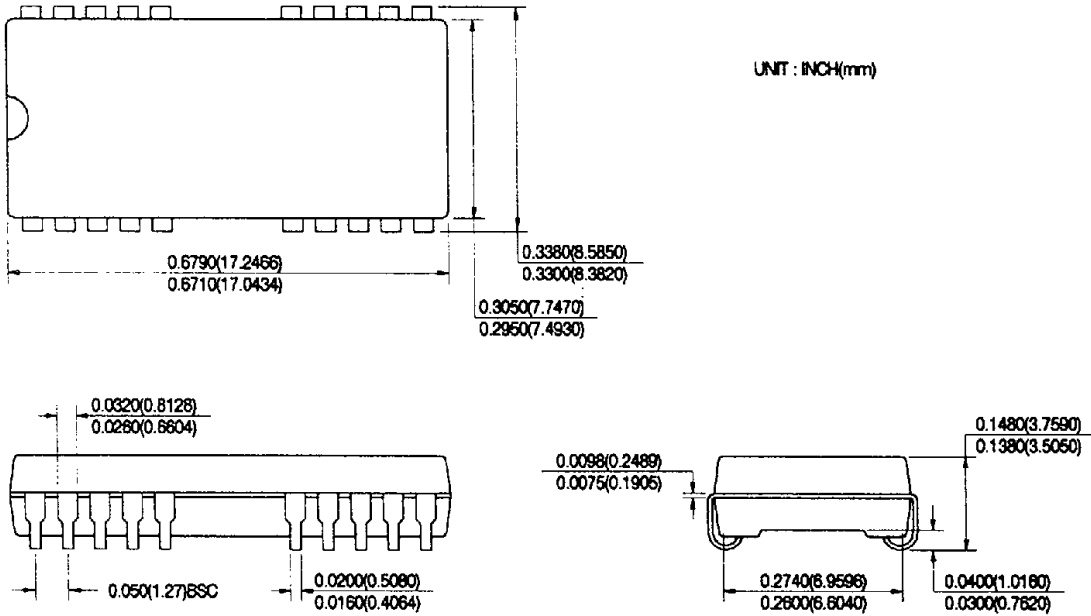

**300 mil 20/26 pin Thin Small Outline Package (T) (R)**

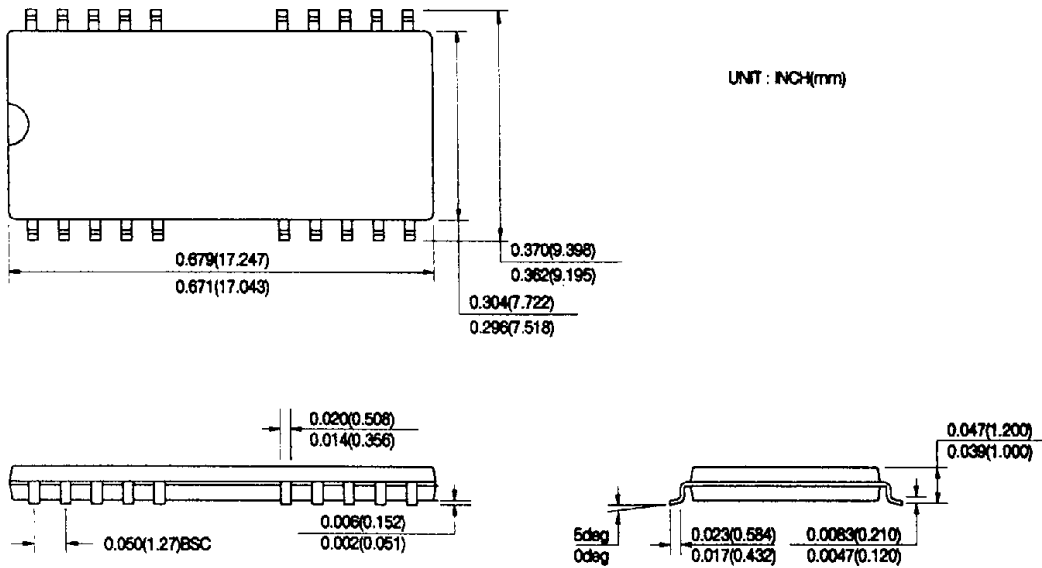

4675088 0004171 431

**ORDERING INFORMATION**

<b>PART NUMBER</b>	<b>SPEED</b>	<b>POWER</b>	<b>PACKAGE</b>
HY514400AJ	50/60/70		SOJ
HY514400ALJ	50/60/70	L-part	SOJ
HY514400AT	50/60/70		TSOP-II
HY514400ALT	50/60/70	L-part	TSOP-II
HY514400AR	50/60/70		TSOP-II(P)
HY514400ALR	50/60/70	L-part	TSOP-II(P)

■ 4675088 0004172 378 ■