

ELECTRIC Part-Turn Type ACTUATOR

DATA SHEET

ZJP

The Electric Actuator Type ZJP permits highly efficient actuation of the final control elements for automatic control system such as butterfly valves, dampers, various types of fans and so on.

The actuator makes it possible to start and stop the final control elements with high reliability and at high repetition rate, with brake motors having strong and excellent braking characteristics.

FEATURES

1. The actuator withstands very frequent start and stop operations.
2. The actuator performs start and stop operations with high reliability to signals.
3. Torque limit switches are built in to assure adequate closing torque for fully closed conditions of valves and to protect them from abnormal overload.
4. The actuator can be equipped with a high performance slide rheostat as a position transmitter or a contactless induction potentiometer for current signal output.
5. The torque limit switches, travel limit switches, position transmitters, etc. are concentrated at a single junction box for easy adjusting.
6. Such an automatic reset system is employed, as with only operating the motor, the actuator is simply changed from "manual" to "auto" mode.
7. The motor comprises overheat protective PTC thermistor sensors.
8. The actuator permits various ways of mounting with the final control elements: direct mounting, direct mounting in floor installation way and mounting with driving lever in floor installation.
9. The system for direct mounting with the final control elements is designed in accordance with international flange standards.

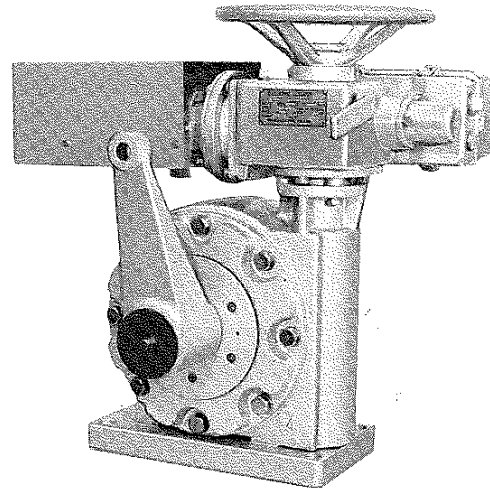

Z J P 4

Starting time: 0.2 sec or less (time required to reach the rated speed after the power is applied to motor)

Braking time: 0.2 sec or less (time required to reach full stop after the power to motor is cut off)

Output torque: ZJP1 16 kg-m
ZJP2 31.5kg-m
ZJP3 63 kg-m
ZJP4 125 kg-m
ZJP5 250 kg-m
ZJP6 500 kg-m

Full stroke: 120°, 90°, 60°

Output shaft speed: 1/1.5, 1/3, 1/4, 1/6 rpm (at 50 Hz)
1/1.3, 1/2.5, 1/3.3, 1/5rpm (at 60 Hz)

Full Stroke Traveling Time (sec at 50 Hz)

Output shaft speed Full stroke	1/1.5rpm (1/1.3rpm)	1/3rpm (1/2.5rpm)	1/4rpm (1/3.3rpm)	1/6rpm (1/5rpm)
120°	30 (25)	60 (50)	80 (67)	120 (100)
90°	23 (19)	45 (37.5)	60 (50)	90 (75)
60°	15 (12.5)	30 (25)	40 (33)	60 (50)

Note 1) Numerals in parentheses denote traveling times at 60 Hz.

SPECIFICATIONS

Control signal: Normal-reverse contact signal
Maximum operating number of switching per hour
1200 sw/h at motor output of 2.2kW or lower
600 sw/h at motor output exceeding 2.2kW
Percentage duty switching; 25% ED

Motor: Output see Table 1
 Power supply
 AC 200/220V, 50/60 Hz, 3φ
 AC 400/440V, 50/60 Hz, 3φ
 AC 220V, 50 Hz, 3φ
 AC 440V, 50 Hz, 3φ
 AC 380V, 50/60 Hz, 3φ
 Number of poles; 4
 Class of insulation; F
 Brake; Electromagnetic brake operating in non-excited condition
 PTC thermistor sensors comprised

Torque limit switch, travel limit switch, intermediate switch: Torque limit switch; 1 each for opening and closing (1a, 1b)
 Travel limit switch; 1 each for opening and closing (1a, 1b)
 Intermediate switch;
 Up to 2 attachable (1a, 1b)

Contact capacity

Power supply	Voltage (V)	Resistive load (A)				Inductive load (A)			
		Resistive load		Lamp load		Inductive load		Motor load	
		NC	NO	NC	NO	NC	NO	NC	NO
AC	125	10	3	1.5	10	4	2		
	250	10	2	1	10	3	1.5		
DC	8	10	6	3	10	6	6		
	14	10	6	3	10	6	6		
	30	6	4	3	6	4	4		
	125	0.4	0.1	0.1	0.4	0.1	0.1		
	250	0.3	0.05	0.05	0.2	0.05	0.05		

Position transmitter:

Slide rheostat;
 Total resistance 120Ω, variable resistance 100Ω up to 2 attachable
 Electronic position transmitter;
 Power supply DC 24V
 Output DC 4~20mA, two-wire system

Heater: For prevents water-drop in switching and signalling unit
 Heater capacity; 10W

Power supply; AC 100V or AC 200V

Mounting: Floor installation or direct mounting

Type of output shaft:
 With driving lever
 (floor installation type)
 Male shaft with key
 (floor installation or direct mounting)

Conduit connection:
 Motor; internal thread PF¼ x 1
 Switching and signalling unit;
 internal thread PF1 x 1
 internal thread PF¼ x 1

Ambient temperature:
 -20~+60°C

Ambient humidity:
 95% RH or less

Enclosure: All weather type (JIS F 8001 Class 3 waterproof construction)

Lubricating fluid:
 Grease

External dimensions:
 See external view

Weight: See Table 1

Finish color: Silver (melamine coating)
 Finish in specified color, acid- and alkali-proof treatment also available.

Scope of delivery:
 Electric actuator
 Lever systems (ball joint and valve lever are supplied upon request)

Table 1 Output Torque – Output Shaft Speed – Motor Output – Weight

Type	Output torque (kg-m)	Output shaft speed (rpm)	Motor output (kW)	Approx. weight (kg)		
				Floor installation type with driving lever	Floor installation type without driving lever	Direct mounting type
ZJP1	16	1/1.5	0.1	63	61	56
		1/3				
		1/4				
		1/6				
ZJP2	31.5	1/1.5	0.2	63	61	56
		1/3	0.1			
		1/4				
		1/6				
ZJP3	63	1/1.5	0.4	87	83	77
		1/3	0.2	85	81	75
		1/4				
		1/6	0.1			
ZJP4	125	1/1.5	0.75	149	140	125
		1/3	0.4	145	136	121
		1/4				
		1/6	0.2	141	132	117
ZJP5	250	1/1.5	1.5	270	258	234
		1/3	0.75	250	238	214
		1/4				
		1/6	0.4			
ZJP6	500	1/1.5	3.7	426	410	360
		1/3	1.5	394	377	327
		1/4				
		1/6	0.75	376	359	310

CODE SYMBOLS

Z	J	P																			Description	
																					Output torque	
																					16 kgm	
																					31.5 "	
																					63 "	
																					125 "	
																					250 "	
																					500 "	
																					Output shaft speed at 50 (60) Hz	
																					1/1.5 (1/1.3) rpm	
																					1/3 (1/2.5) "	
																					1/4 (1/3.3) "	
																					1/6 (1/5) "	
																					Full stroke	
																					120°	
																					90°	
																					60°	
																					Mounting	
																					A	Floor installation with driving lever
																					B	Floor installation without driving lever
																					C	Direct mounting
																					Position transmitter	
																					0	None
																					1	With slide rheostat: Total resistance 120Ω and variable resistance 100Ωx1 each
																					2	With slide rheostat: Total resistance 120Ω and variable resistance 100Ωx2 each
																					3	With electronic position transmitter (output increased by turning output shaft CW)
																					4	With electronic position transmitter (output increased by turning output shaft CCW) Note) Output shaft rotating direction when looking toward output shaft.
																					Power supply	
																					F	AC 200/ ²⁰⁰ / ₂₂₀ V, 50/60 Hz
																					H	AC 220V 50 Hz
																					K	AC 400/ ⁴⁰⁰ / ₄₄₀ V, 50/60 Hz
																					M	AC 440V 50 Hz
																					P	AC 380V 50/60 Hz
																					Intermediate switch	
																					0	None
																					1	With 1a and 1b, one each
																					2	With 1a and 1b, 2 each
																					Heater	
																					0	None
																					1	With space heater (for AC 100V)
																					2	With space heater (for AC 200V)
																					Accessories	
																					Y	None
																					A	With ball joint
																					B	With valve lever
																					C	A + B
																					Non-standard specifications	
																					A	Non-standard finish color
																					W	Acid- and alkali-proof coating
																					Z	Other non-standard specifications

CONSTRUCTION

Structural Diagram of ZJP4

- ① Reduction mechanism of actuator main unit
- ② Motor
- ③ Switching and signaling unit
- ④ Handle
- ⑤ Manual changing lever
- ⑥ Worm shaft assembly
- ⑦ Torque detecting pin

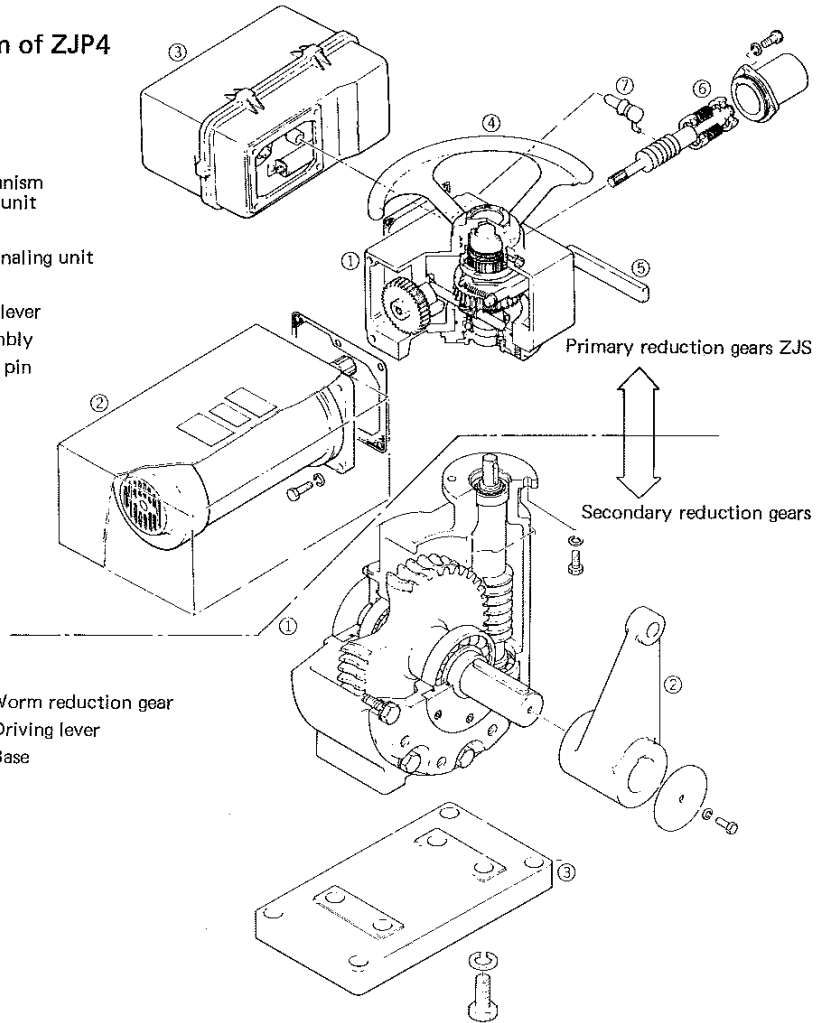

Structural Diagram of Switching and Signaling Unit (Common to All Types)

- ① Casing
- ② Mounting board
- ③ Torque limit switches
- ④ Travel limit switches
- ⑤ Travel limit switches (in case of a single intermediate switches)
- ⑥ Travel limit switches (in case of two intermediate switches)
- ⑦ Slide rheostat x 1
- ⑧ Slide rheostat x 2
- ⑨ Electronic position transmitter
- ⑩ Heater
- ⑪ Terminal
- ⑫ Cover

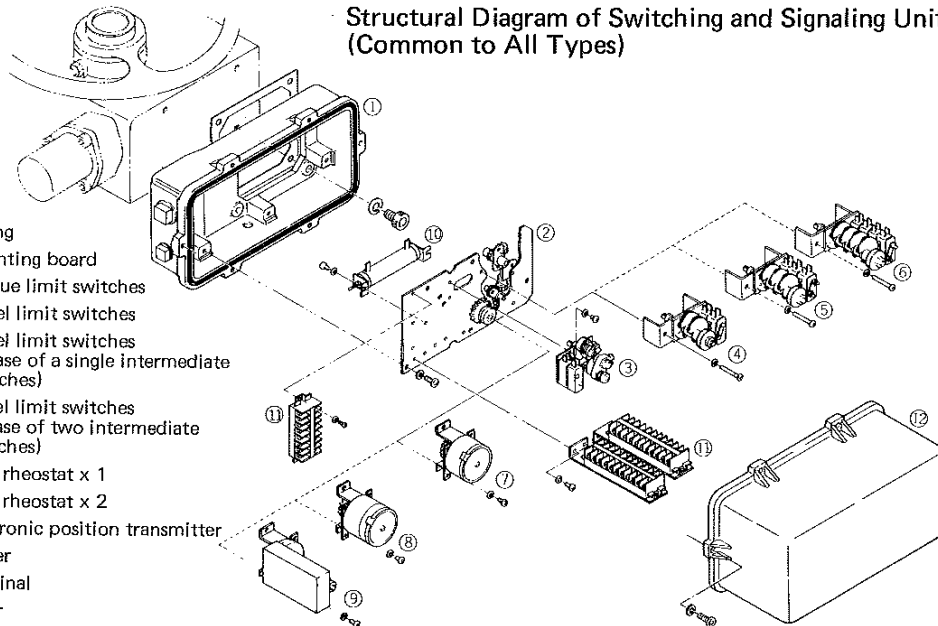

EXTERNAL VIEW (Unit: mm)

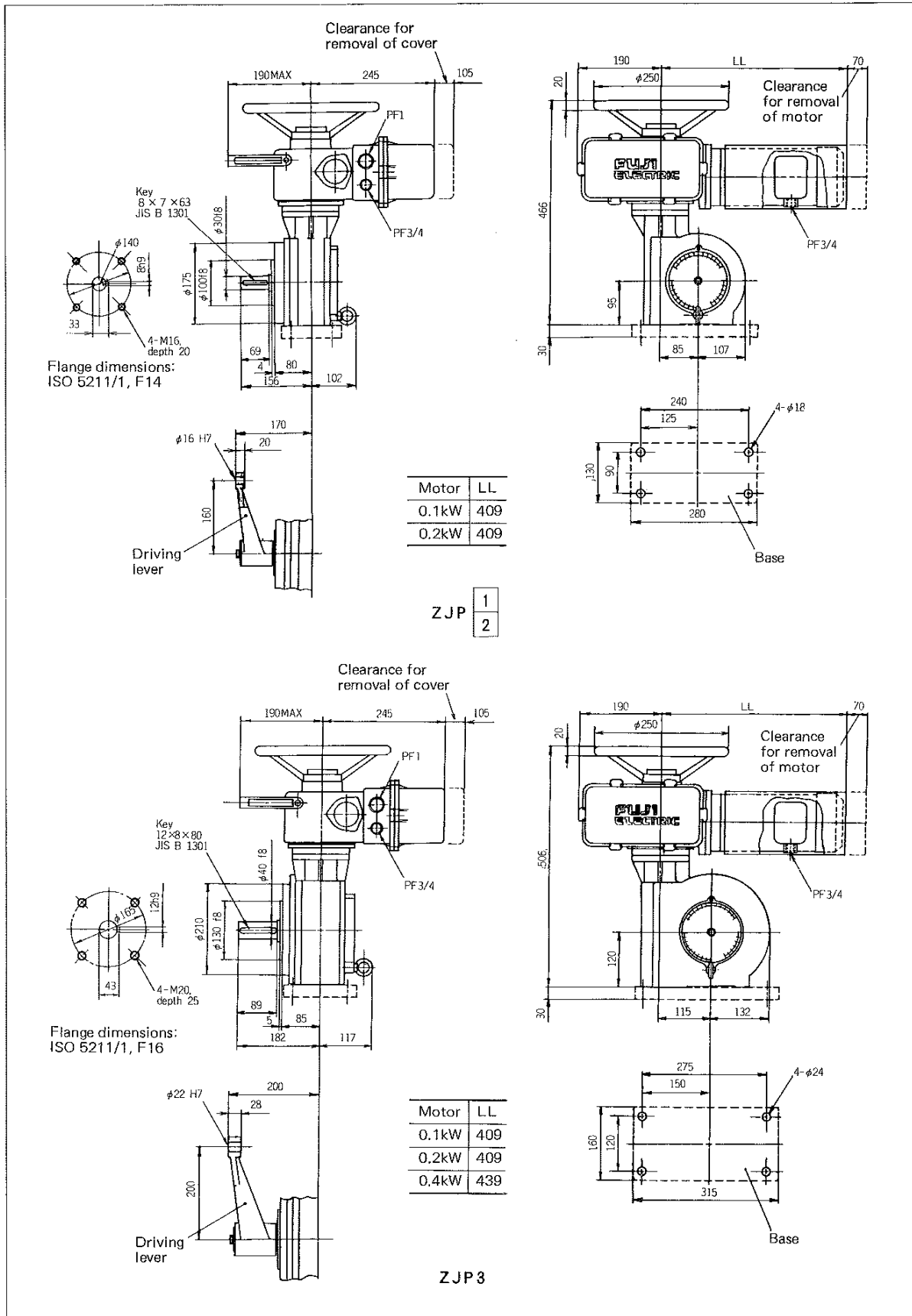

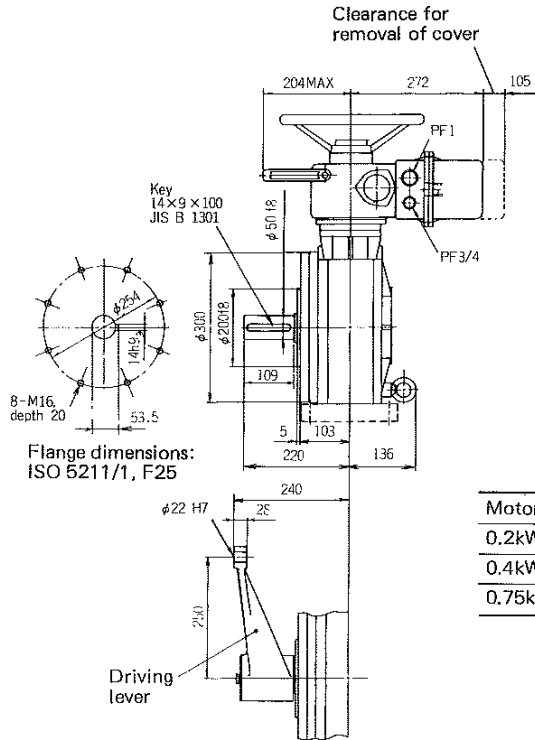

Motor	LL
0.2kW	435
0.4kW	464
0.75kW	497

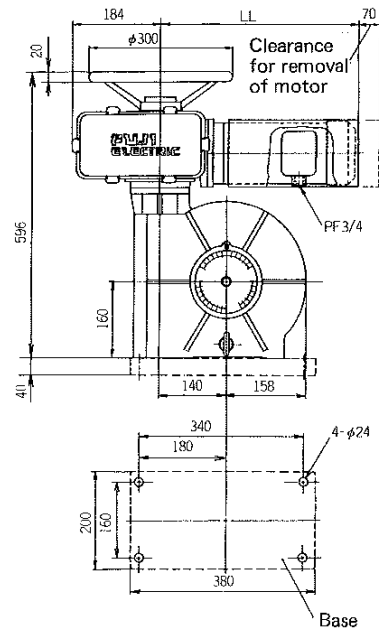

ZJP4

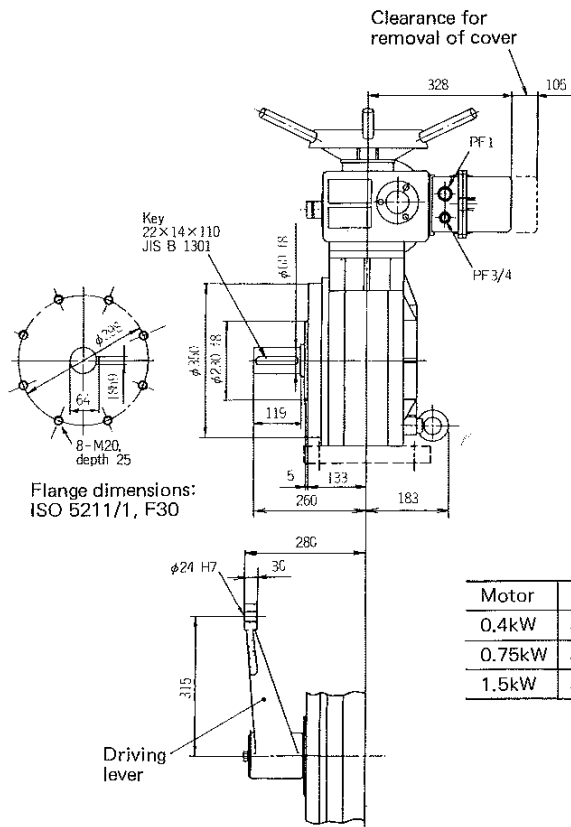

Motor	LL
0.4kW	317
0.75kW	350
1.5kW	398

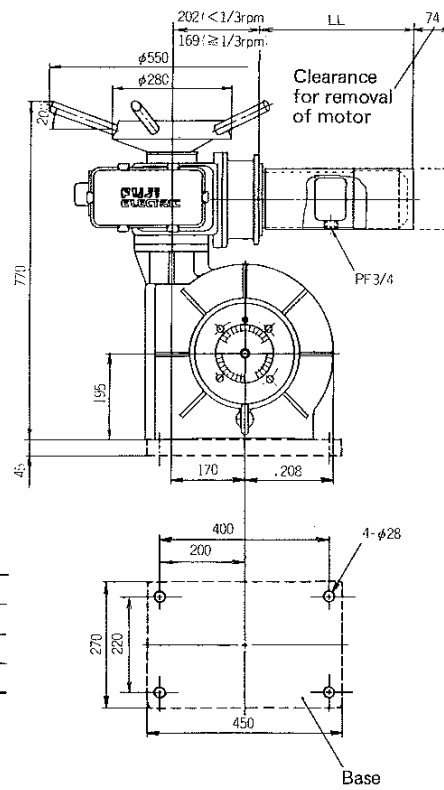

ZJP5

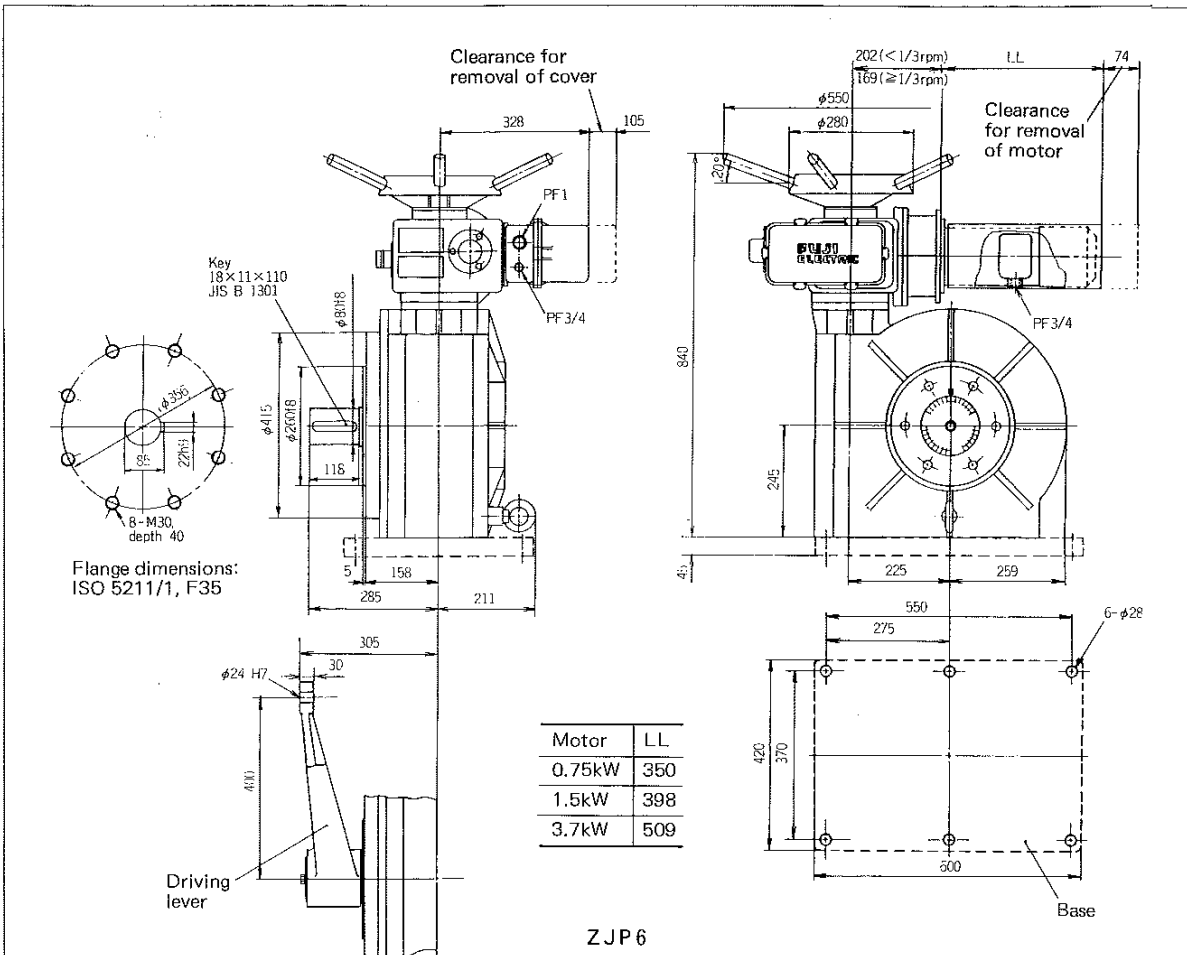

Lever systems

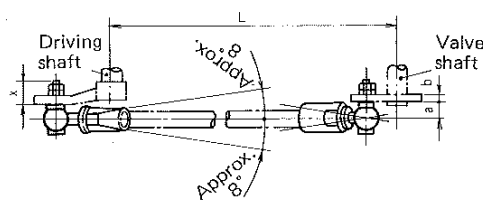

Details of C

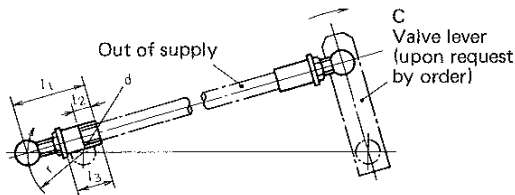
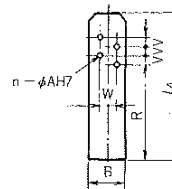

Application	r	l ₁		l ₂	l ₃	d	L		a	b	x	φAH7	B	l ₄	n	R	V	W
		MIN	MAX				MIN	MAX										
ZJP1,2	160	110	140	25	75	PF 3/4	400	2400	20	22	44	16	40	200	4	125	15	14
ZJP3	200	110	135	30	60	PF 1 1/4	800	3300	38	28	56	22	60	440	4	310	30	0
ZJP4	250	135	155	32	80	PF 2	1200	4750	37	30	64	24	100	560	4	375	45	0
ZJP5	315	135	155	32	80	PF 2	1200	4000	37	30	64	24	100	560	4	375	45	0

Note: The output shaft turns counterclockwise as seen by the operator facing the shaft and turning the handle clockwise.

CONNECTION DIAGRAM

Motor

(1) For output of 0.4kW or less

(2) For output of 0.75kW to 3.7kW (double voltage system)

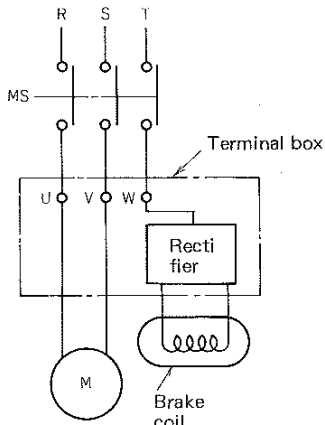

200/200 V 50/60Hz

R	S	T
U ₁	V ₁	W ₁
U ₂	V ₂	W ₂
Z ₁	X ₁	B ₁
Y ₁ -Y ₂ -B ₂		

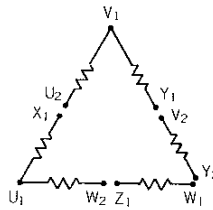

400/400 V 50/60Hz

R	S	T
U ₁	V ₁	B ₁
U ₂	V ₂	W ₂
X ₁	Y ₁	Z ₁
W ₁ -Y ₂ -B ₂		

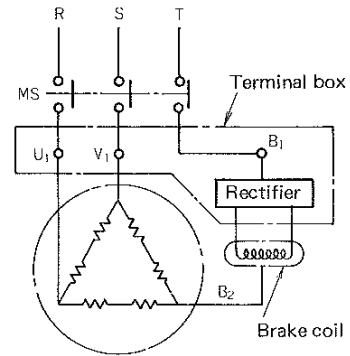
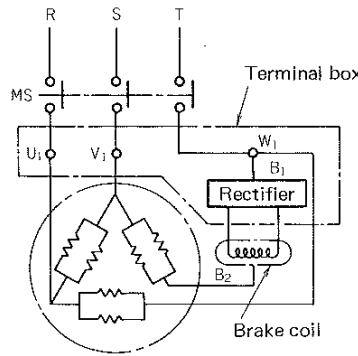

In the connection illustrated above, the output shaft turns CCW as seen by the operator facing the shaft. In case of ZJP5C, ZJP5D, ZJP6C and ZJP6D, however, rotating direction is reversed.

Switching and signaling unit

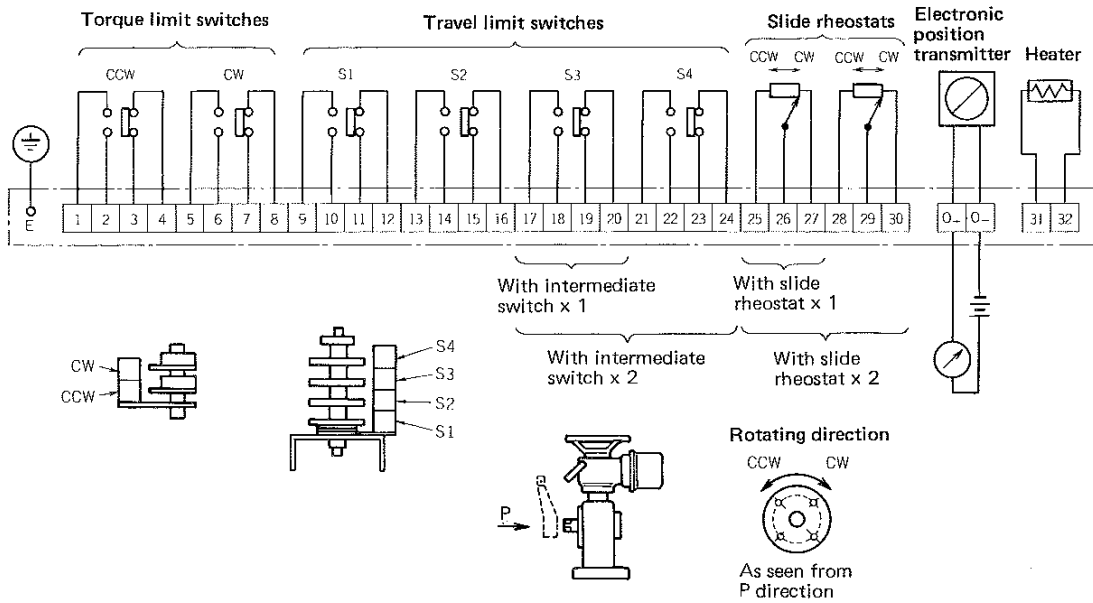

RELATED EQUIPMENT

Motor guard relay unit (to be prepared separately)
It is to be prepared for protecting the motor with PTC thermistor sensors.

1. Type

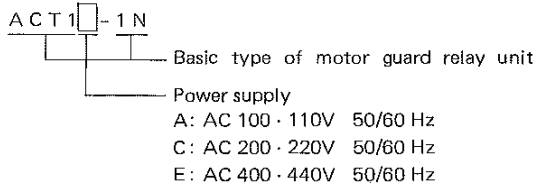

2. Motor Guard Relay Unit Circuit

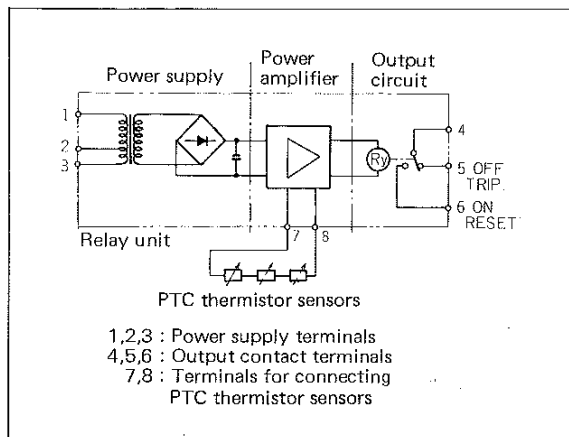

3. External View

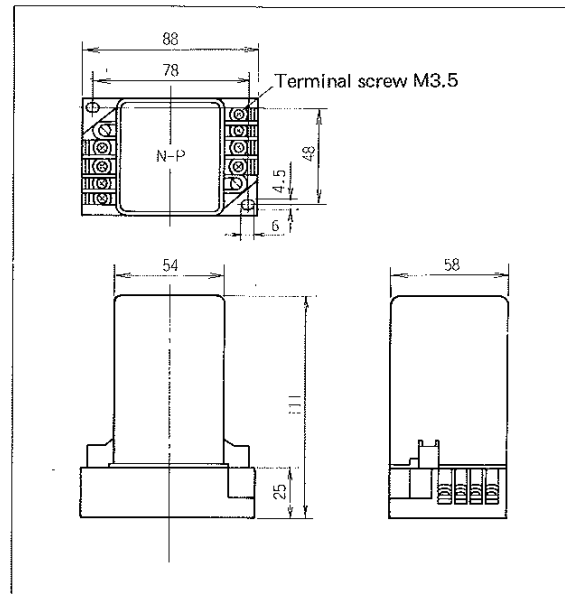

Note) • Alteration reserved without notice.
• Asterisked (*) items ; Nonstandard.



Fuji Electric Co.,Ltd.

New Yurakucho Bldg., 12-1 Yurakucho 1-chome,
Chiyoda-ku, Tokyo, 100 Japan
Phone : Tokyo 211-7111
Telex : J22331 FUJIELEC
Cable Address : DENKIFUJI TOKYO