

Z SERIES MICRO CONTROLLER E

(STANDARD TYPE, DUAL TYPE) — 48 × 96mm, 72 × 72mm, 96 × 96mm —

DATA SHEET

PYZ5, 7, 9

Micro controller E (PYZ) is a small, economical temperature controller containing a microprocessor and sizing 48 x 96, 72 x 72, or 96 x 96mm according to DIN standard.

It accepts inputs from thermocouples, resistance bulbs, thermistors, or voltage/current, and provides numerous control functions ranging of on/off control and PID control.

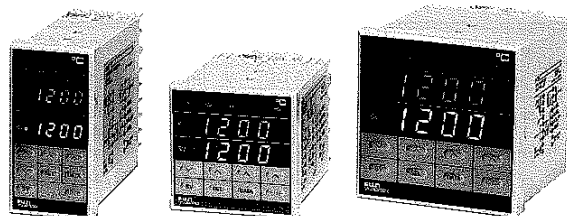

FEATURES

1. **Multiple inputs, easy programmable range**
The micro controller E accepts inputs from 6 different types of thermocouples and 1 type of resistance bulbs. Alterations of input range can readily be made at the site. Voltage/current input type is also available.
2. **Wide range of power supply**
The micro controller E can be operates on AC voltage ranging from 85 to 265V.
3. **Standard type with PID auto-tuning function**
Auto-tuning function is provided to obtain PID parameters suited for process.
4. **Heater break alarm**
A heater break alarm can be provided.
5. **Dust/drip-proof front panel**
Front panel is dust/drip-proof complying with IEC IP55.
6. **Compactness**
Instrument depth is only 100mm or less, allowing installation in a limited space.

SPECIFICATIONS

1. Control functions

— Standard type —

- (1) PID control: Proportional band (P): 0 to 999.9%
Integral time (I): 0 to 9999 sec
Derivative time (D): 0 to 3600 sec
(2-position control at P, I, D=0, proportional action at I, D=0)

* (2) PID auto-tuning

- (3) Proportional cycle:
1 to 150 sec
(contact; SSR/SSC drive output)

- (4) Hysteresis width:
0 to 20% (for 2-position action)

- (5) Anti-reset windup:
0 to 100% variable

- (6) Control cycle: 0.5 sec

Note* : Refer to the functions description in page 5.

— Dual output type —

(1) PID control mode:

Heating proportional band (P): $P \times \frac{1}{2}$ (P=0 to 999.9%)

Cooling proportional band (P): Heating proportional band x cooling proportional band coefficient

Proportional band coefficient for cooling (COOL): 0.0, 0.1 to 100.0

(2-position control without hysteresis at COOL: 0.0)

Integral time (I): Same as standard type

Derivative time (D): Same as standard type
2-position control (both heating and cooling) at P, I, D=0

Proportional action at I, D=0

(2) PID auto-tuning:

Heating only

(3) Proportional cycle:

1 to 150 sec
(contact output, SSR/SSC drive output)

(4) Hysteresis width:

0 to 20% for 2-position action (both heating and cooling)

(5) Anti-reset windup:

0 to 100% variable

(6) Overlap/dead band:

±50% of half proportional band

(7) Control cycle: 0.5 sec

2. Input

(1) PV input signal:

Type	Input	Remarks
I	Thermocouple input J K R T N (Nichrosil-Nisil) PL-II (Platinel)	<ul style="list-style-type: none"> • Cold junction compensating function built in • Burnout circuit built in • Influence of external wiring resistance is approx. 0.5μV/Ω
	Resistance bulb input Pt100 (IEC Pub 751-1983)	<ul style="list-style-type: none"> • Burnout circuit built in • Influence of external wiring resistance is 0.015%/Ω (per wire) of reading
III	Voltage input 1 to 5V DC	Input resistance, 400k Ω
	Current input 4 to 20mA DC	Input resistance, 250 Ω

Remarks: (1) Selection between thermocouple input and resistance bulb input in Type is made by using the select pin in the instrument.
 (2) For 4 to 20mA DC input in Type III, a 250 Ω resistor is supplied for connection to the input terminal.
 (3) For selection between 4 to 20mA and 1 to 5V DC, remove the 250 Ω resistor.
 (4) Instrument using B, E and S thermocouple inputs is also available as non-standard item.

(2) Input range (): Decimal point acceptable optional

Input	$^{\circ}$ C		$^{\circ}$ F	
	Range	Min. range	Range	Min. range
Pt100	-150 to 400 (-150.0 to 300.0)	50 (100.0)	-238 to 752	90
J	0 to 1000 (0.0 to 300.0)	200	32 to 1832	360
K	0 to 1200 (0.0 to 300.0)	200	32 to 2192	360
R	0 to 1600	1000	32 to 2912	1800
T	-200 to 400 (-200.0 to 300.0)	200	-328 to 752	360
N (Nichrosil-Nisil)	0 to 1300 (0.0 to 300.0)	200	32 to 2912	360
PL-II (Platinel)	0 to 1300 (0.0 to 300.0)	200	32 to 2372	360
1 to 5V DC	-1999 to 3000 (engineering unit setting)			
4 to 20mA DC	Decimal point acceptable optional			

(3) Burnout

Control output is held at upper/lower maximum value when temperature sensor open.
 For resistance bulb input, detection is allowed even if any of the three wires is discontinued.

3. Output

- Standard type -

Control output: Of the following output types, any one should be specified.

Current output	4 to 20mA DC	Allowable load resistance 600 Ω or less. Ripple approx. 1.5%FS*/2Hz
Contact output	SPDT contact	Electrical expect. life 220V AC, 3A, resistive load 10 ⁵ cycle Mechanical expect. life 10 ⁷ cycle
SSR/SSC driver output	Transistor output	ON : 60mA max./24V DC typical OFF: 0.3V max.

Note: * FS: Full scale

- Dual output type -

Control output: Of the following output types, any one should be specified for each of the heating and cooling sides.

Current output	4 to 20mA DC	Allowable load resistance 600 Ω or less. Ripple approx. 1.5%FS/2Hz
Contact output	SPDT contact	Electrical expect. life 220V AC, 3A, resistive load 10 ⁵ cycle Mechanical expect. life 10 ⁷ cycle
SSR/SSC driver output	Transistor output	ON : 60mA max./24V DC* typical OFF: 0.3V max.

Note: * When both outputs are SSR/SSC driver output, total of both output-current should be less than 60mA.

4. Setting and indication

(1) Accuracy: \pm 0.5%FS \pm 1 digit
 \pm 5%FS \pm 1digit : R thermocouple 0 to 400 $^{\circ}$ C

(2) Setting method:
 Key operation

(3) Indication method:
 Digital setting; PV/SV independent display (PV: red, SV: green)

(4) Status indication:
 Control output
 High alarm
 Low alarm
 Heater break alarm

5. Alarm (option)

(1) High/low alarm:
 One type of alarm can be selected from those in Fig. 1 by using the front panel key.

Alarm output: 2 contacts

Relay contact output	SPST contact	Resistive load; 220V AC, 1A
----------------------	--------------	-----------------------------

(2) Heater break alarm:

- Heater break can be detected only on single-phase heater
- Current transformer (CT)* primary input: 1 to 50A
- Output

Relay contact output	SPST contact	Resistive load; 220V AC, 1A
----------------------	--------------	-----------------------------

Heater power voltage compensating function is provided.

(This function is effective when the heater and the instrument operate with the same power source.)

Note: * Current transformer (CT) is required separately from the instrument (CT is mounted on the outside of the instrument.)

6. Power failure processing

Set values, PID parameters are retained in nonvolatile memory and restarts automatically.

7. Self-diagnosis function

Program monitoring with watchdog timer

8. Operating and storage conditions

- (1) Ambient temperature:
 -10 to +50 $^{\circ}$ C
- (2) Ambient humidity:
 90%RH or less (no condensation)
- (3) Storage temperature:
 -20 to +60 $^{\circ}$ C

9. General specifications

(1) Power supply: 85 to 265V AC

(2) Power consumption:

Approx. 10VA/100V AC, approx. 18VA/220V AC

(3) Dielectric strength:

1500V AC for 1 min.

(earth to power source, earth to relay output, earth to alarm output)

500V AC (other)

(4) Insulation resistance:

50MΩ or more (500V DC)

10. Structure

(1) Mounting method:

Panel flush mounting

(2) Enclosure: Plastic housing

(3) External dimensions:

96(H) x 48(W) x 100(D) mm (PYZ5)

72(H) x 72(W) x 100(D) mm (PYZ7)

96(H) x 96(W) x 100(D) mm (PYZ9)

(4) Mass(weight) (approx.):

300g (PYZ7, PYZ5)

400g (PYZ9)

(5) Finish color: Munsell 5Y 8/1 (front panel frame, case)

11. Scope of delivery

Controller and mounting bracket

[Item to prepare separately: Current transformer (CT) for detecting heater break alarm]

CODE SYMBOLS

1	2	3	4	5	6	7	8	9	10	Description
P	Y	Z						2	V	Front panel dimensions [mm]
				5						48 x 96
				7						72 x 72
				9						96 x 96
										Input signal
				T						Thermocouple [°C]
				R						Thermocouple [°F]
				N						Resistance bulb, Pt100Ω, 3-wire (IEC) [°C] (*2)
				S						Resistance bulb, Pt100Ω, 3-wire (IEC) [°F] (*2)
				B						4 to 20mA DC
				A						1 to 5V DC
										Control output 1
				A						Contact (reverse action)
				B						Contact (direct action)
				C						SSR or SSC driver output (reverse action)
				D						SSR or SSC driver output (direct action)
				E						4 to 20mA DC (reverse action)
				F						4 to 20mA DC (direct action)
										Control output 2 for dual output type
				Y						None
				A						Contact (reverse action)
				B						Contact (direct action)
				C						SSR or SSC driver output (reverse action)
				D						SSR or SSC driver output (direct action)
				E						4 to 20mA DC (reverse action)
				F						4 to 20mA DC (direct action)
										Additional functions
				0						None
				1						With high/low alarm
				2						With heater break alarm (*1)
				3						With high/low alarm and heater break alarm (*1)

Note: * (1) With current output, a heater break alarm type is not available.

(2) Symbol for resistance bulb is as follows

Pt100 ... IEC Pub. 751-1983

(3) Range can be set by the front key.

(4) If the range is not designated on order, the product will be delivered with the following range selected.

Input signal code "T": K thermocouple 0 to 400°C

Input signal code "N": 0 to 200°C

Input signal code "A", "B": 0 to 100%

Fig. 1 Kinds of alarms:

	Function	Action
Deviation alarm	High/low alarm, (*) without low hold	
	High alarm	
	Low alarm, without low hold	
	High/low alarm, with low hold	
	Low alarm, with low hold	
Absolute value alarm	High/low alarm, without low hold	
	High alarm	
	Low alarm, without low hold	
	High/low alarm, with low hold	
	Low alarm, with low hold	
	High/two high	
	Low/two low, without low hold	

	Function	Action	
Absolute value + Deviation alarm	Absolute value	Deviation	
	High alarm	Low alarm	
	Low alarm	High alarm	
	Low alarm, with low hold	High alarm	
	High alarm, with low hold	Low alarm, with low hold	
Zone alarm	High alarm	High alarm	
	Low alarm	High alarm	
	Absolute value	Absolute value	
	Deviation	Absolute value	
	Absolute value	Deviation	
	Deviation	Deviation	

Remarks: (1) Low alarm with hold is a function to turn OFF the lower limit alarm when temperature is below the set value at ON of instrument power source, and when the temperature rises above the set value of AL and then lowers again, the lower limit alarm is turned ON.

(2) Alarm output in the shaded area turns ON.

(3) * When specified, two high, two low alarm can be supplied.

(4) Alarm type at shipping is deviation high/low alarm with low alarm hold in the area.

Parameter function

- This instrument incorporates primary (setpoint) and secondary (system) parameters so that setting operation can be made by using the front panel keys according to operating conditions. (By pressing the SEL key for about 5 seconds, secondary parameter is selected. By pressing the same key for about 5 seconds again, primary parameter is selected.)

• **Primary (setpoint) menu**

Display	Item	Description
SV	Main setpoint	Settable within the input range
P	Proportional band	Setting range: 0.0 to 999.9% For on/off control set to "0"
I	Integral time (reset)	Setting range: 0 to 9999 sec. Integral action is off when cut to "0"
D	Derivative time (rate)	Setting range: 0 to 3600 sec. Derivative action is off when set to "0"
AL ^(*1)	Low alarm setpoint	Settable within the input range Not indicated without the alarm output option
AH ^(*1)	High alarm setpoint	Settable within the input range Not indicated without the alarm output option
TC	Cycle time (output 1)	Setting range: 1 to 150 sec. Not indicated within current output
HYS	Hysteresis (output 1)	Setting range: 0.0 to 20.0% FS
Hb ^(*2)	Heater break alarm	Setting range: 0.0 to 50.0 A Not indicated without the heater break alarm output option Not available with the ramp-to-set point option Alarm is off when set to "0"
AT	Auto-tuning	Sets P,I,D parameters internally (Reverse or direct) 0: Auto-tuning off 1: Standard auto-tuning 2: Below setpoint auto-tuning (10%FS below setpoint)
TC2 ^(*3)	Cycle time (output 2)	Setting range: 1 to 150 sec. Not indicated without control output 2 option Not indicated with current output
COOL ^(*3)	Proportional band coefficient for cooling	Setting range 0.0 to 100.0 Not indicated without control output 2 option For on/off control set to "0"
db ^(*3)	Dead band/overlap	Setting range: -50.0 to +50.0 Not indicated without control output 2 option
LOC	Lock-up	Program data lock-up: (code) 0: All data is selectable 1: All data is locked-up 2: All data except for main setpoint is locked-up

Note: *1 is displayed for the type with alarm, *2 is displayed for the type with heater break alarm, *3 is displayed for the dual output type.
Don't input parameter's value out of setting range above.

- When the instrument is left as it is for about 30 seconds following key operation, the parameter display automatically turns to PV display.

• **Secondary (system) menu**

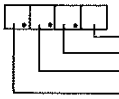
Display	Item	Description
P-n1	Control action	Setting control action: (code) Reverse or direct Setting sensor break Protection: (code) Upscale or downscale
P-n2	Input type	Setting input type: Thermocouple or resistance bulb Current or voltage
P-dF	Digital filter	Setting: (code) 0 to 201 1/2 of setting=63% response time
P-SL	Low limit of input range	Setting range: -1999 to 3000
P-SU	High limit of input range	Setting range: -1999 to 3000
P-Ab	Alarm type	Setting: (code) Choices of deviation, absolute, and combination type alarm configurations
P-An	Alarm hysteresis	Setting range: 0 to 255 (engineering unit)
P-dP	Decimal point position	Select the decimal point position for PV/SV indication  <ul style="list-style-type: none"> No decimal point → "0" One decimal digit → "2" Two decimal digits → "4" Three decimal digits → "8"
P-4B		Not to be changed.
P-CT	Load (heater) voltage	Setting: voltage used for heater (85 to 265V AC) For the heater break alarm option only Not available with the ramp-to-setpoint option
PVOF	Process variable offset	Setting range: -1999 to +2000 Indicated process variable is changed Measured process variable is unchanged
SVOF	Setpoint variable offset	Setting range: -1999 to +2000 Indicated setpoint variable is unchanged Measured setpoint variable is changed
P-F	°C/°F selection	Setting: (code) 0: °C 1: °F
dSP1	Primary parameter skip	Setting of presence or absence of any parameter display P, I, D, AL, AH, TC or HYS.
dSP2	Primary parameter skip	Setting of presence or absence of any parameter display Hb, AT, TC2, COOL or db.
dSP3	Primary parameter skip	Not to be changed.

Functions

(1) Auto-tuning

PID parameters are automatically set by controller's measurement and operation function.

This instrument provides 2 types of auto-tuning functions; the standard type (auto-tuning, with SV used as reference) and the low SV type (auto-tuning, with the value 10% below SV used as reference).

(a) Standard type

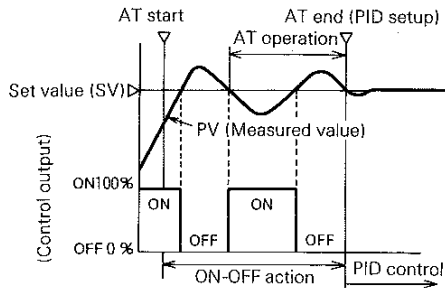

(b) Low PV type

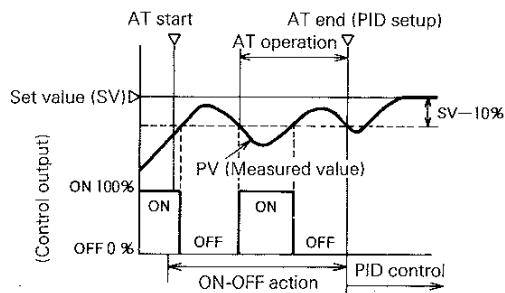

- Remarks: (1) PID parameter which has been automatically set at the completion of auto-tuning is saved even when the power is turned OFF, eliminating the need for auto-tuning for succeeding operations.
 (2) During auto-tuning, control output turns ON and OFF, which largely changes the value of PV depending on process. Do not use the auto-tuning function if such a phenomenon is not allowed.
 (3) Do not use the auto-tuning function for a process having a quick response, such as pressure control, flow control, etc.

(2) Dual output (option)

The controller incorporates both the heating output and the cooling output for setting "cooling control cycle", "cooling proportional band" and "dead band or overlap band".

(a) Setting of cooling proportional band

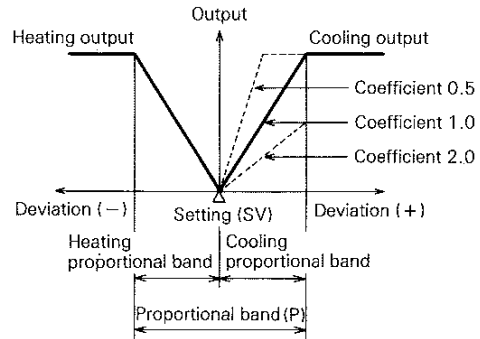

In cooling side proportional band, coefficient is set with respect to heating side proportional band. (ON-OFF action at coefficient 0)

(b) Setting of cooling side proportional band shift

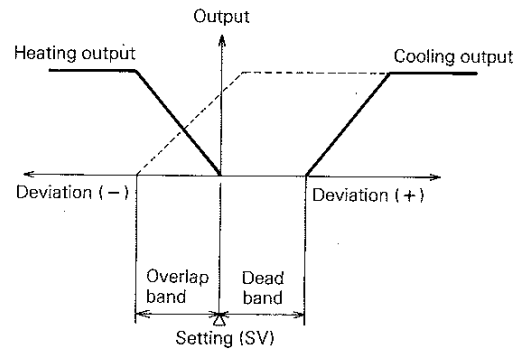

Setting range: 0 to $\pm 25\%$ of proportional band
 Overlap band: -50 to 0
 Dead band: 0 to 50

- Remarks: (1) PID auto-tuning is carried out only on the heating side. During auto-tuning, output of the cooling side remains turned off. After auto-tuning, both heating and cooling operations are performed according to the same PID values.
 (2) ID set value is the same between heating and cooling sides. Individual setting cannot be accepted.

(3) Heater break alarm (option)

Heater break alarm is output immediately when the heater wire has been broken.

- Use the current transformer (CT) specified by Fuji.
- Heater break is detected only when single-phase heater is used.
- Heater break alarm is not available when controlling the heater by thyristor phase-angle control method.
- [Current setting for heater break alarm, "HB"] are registered using of front key.

P
•

- Example of connection of heater break alarm (PYZ5, PYZ9)

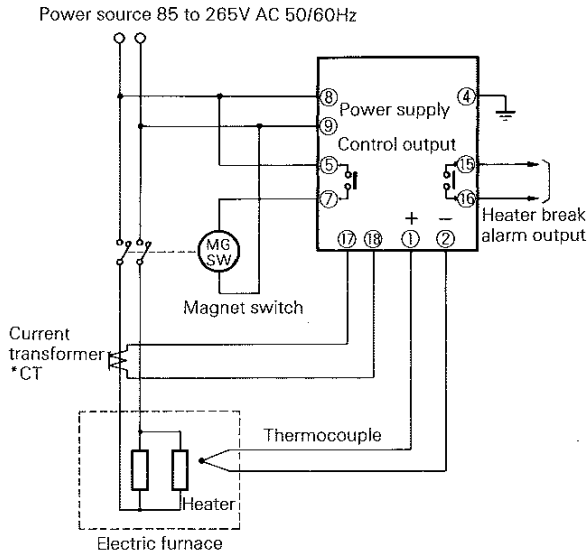

(4) Fault display

This instrument provides fault display functions.

Display	Cause
U U U U	(1) Thermocouple sensor burnout (when burnout direction is up scale) (2) Resistance bulb sensor burnout (when burnout direction is up scale) (3) PV display value in excess of 30% above the max. value in measurement range
L L L L	(1) Thermocouple sensor burnout (when burnout direction is down scale) (2) Resistance bulb sensor burnout (when burnout direction is down scale) (3) Resistance bulb sensor short-circuit (between A and B) (4) PV display value declined 30% below the min. value in measurement range

Note: The above display may not be obtained depending on input type and input range.

•
I
D
S
P
I
D
A
A
T
F
F

OUTLINE DIAGRAM (Unit: mm)

Type	External dimensions	Panel cutout												
PYZ 5		<p>Mounting of 1 unit</p> <p>Mounting of "n" units (2 ≤ n ≤ 6)</p> <table border="1"> <thead> <tr> <th>Quantity</th> <th>2</th> <th>3</th> <th>4</th> <th>5</th> <th>6</th> </tr> </thead> <tbody> <tr> <td>a</td> <td>93</td> <td>141</td> <td>189</td> <td>237</td> <td>285</td> </tr> </tbody> </table> <p>For close mounting of instruments with 200V system power source, it is recommended to install a cooling fan for dissipating heat.</p>	Quantity	2	3	4	5	6	a	93	141	189	237	285
Quantity	2	3	4	5	6									
a	93	141	189	237	285									
PYZ 7														
PYZ 9														

Option device

Heater break alarm current transformer (CT)

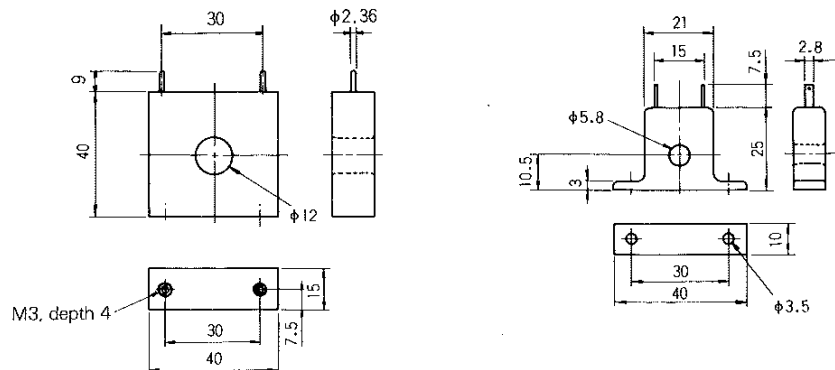

CONNECTION DIAGRAM

PYZ5

PYZ9

— Standard type —

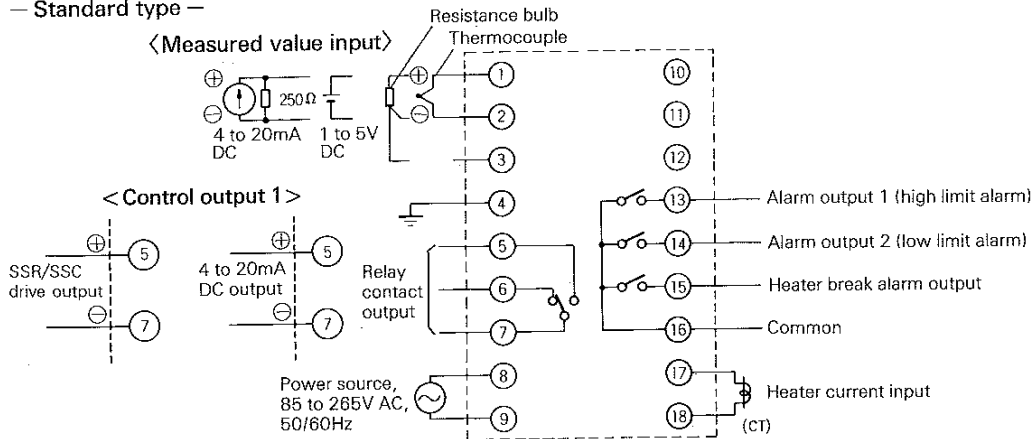

— Dual output type —

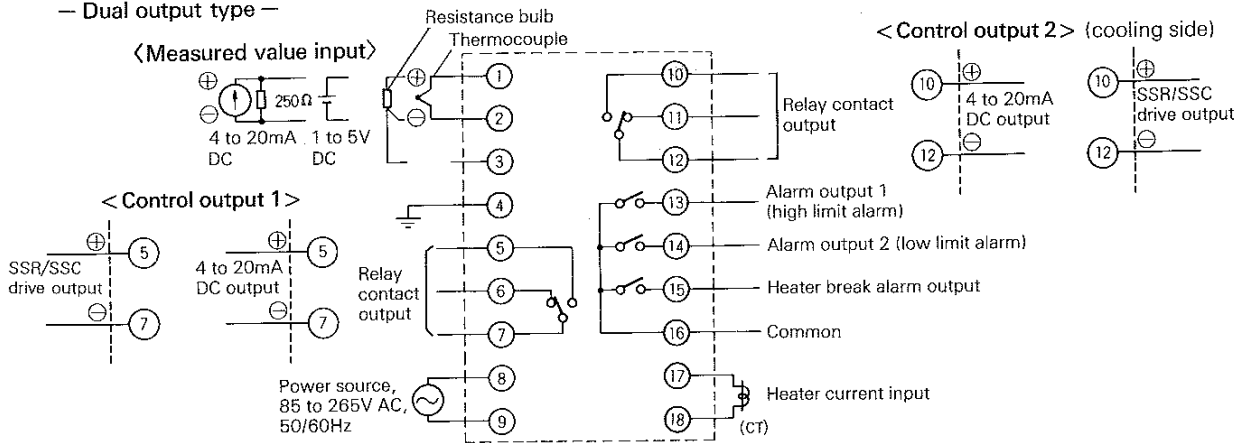

Remark: SSR/SSC drive output and 4 to 20mA DC output are not electrically isolated from the internal circuit. Be sure to use non-grounded type sensor.

PYZ7

— Standard type —

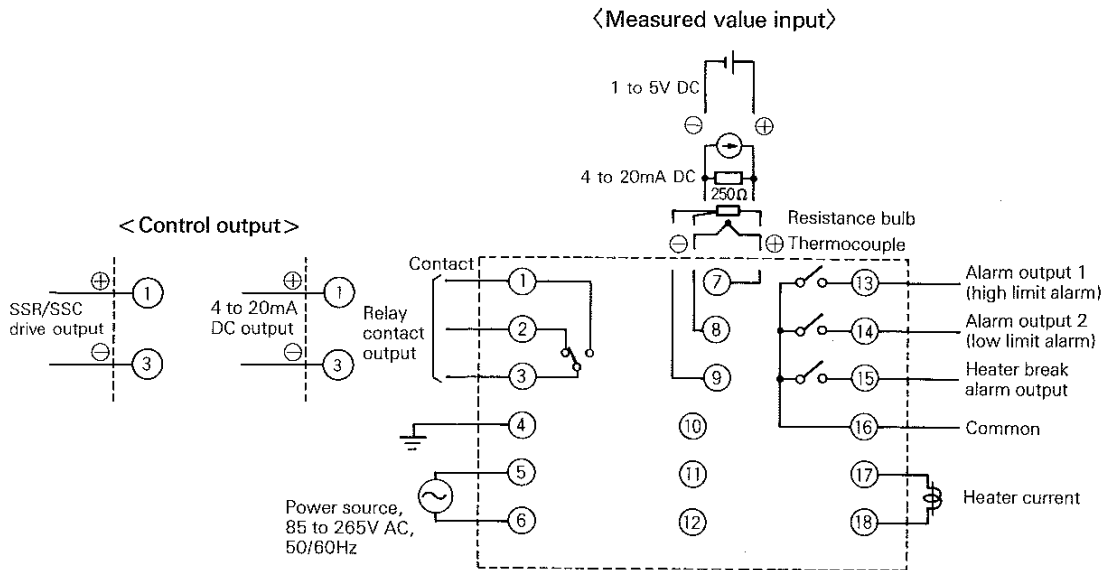

— Dual output type —

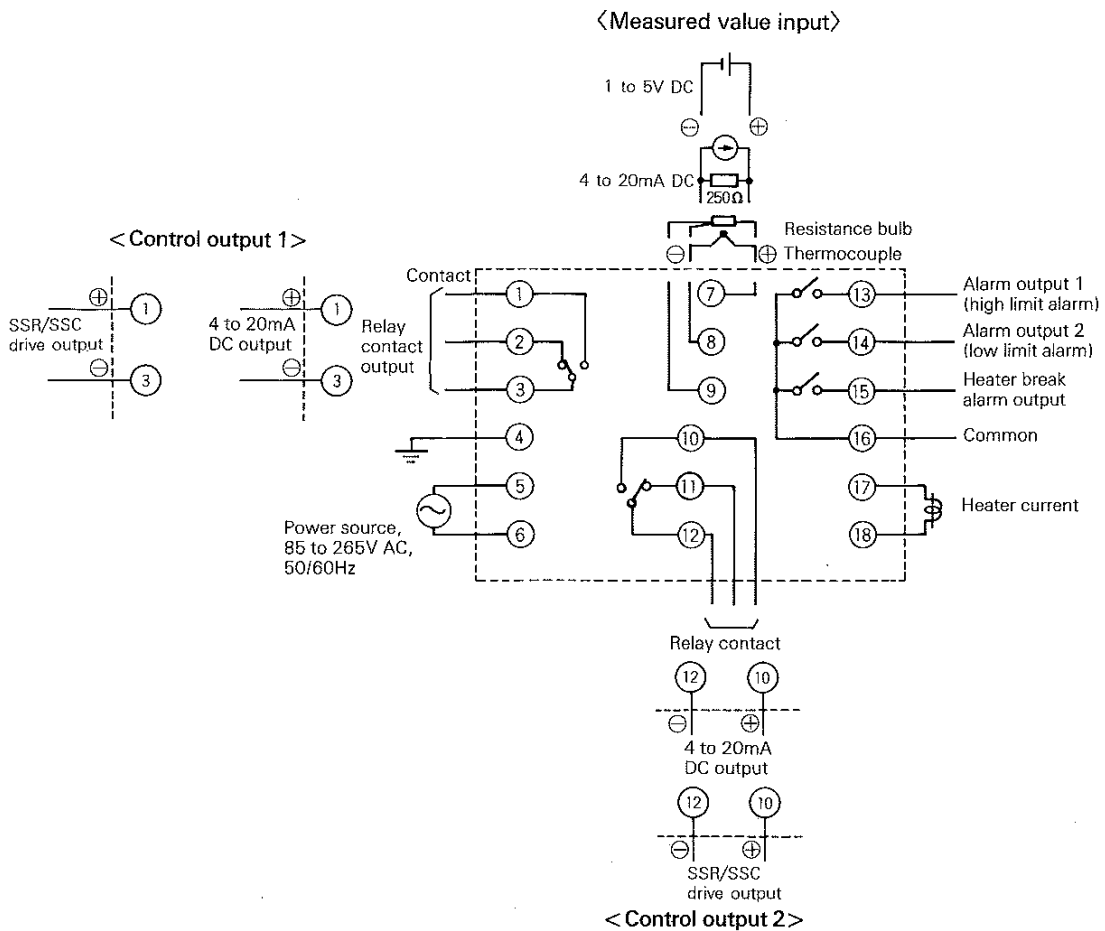

Remark: SSR/SSC drive output and 4 to 20mA DC output are not electrically isolated from the internal circuit. Be sure to use non-grounded type sensor.