

FC SERIES MANUAL LOADER (STEP OUTPUT TYPE)

DATA SHEET

PND1

The FC series manual loader is available in two types, a manual control type and a remote control type used in combination with a compact controller.

This instrument is equipped with a solid state indicator and pushbutton operation circuit to provide easy readouts and handling for process operation by man-machine communication.

It can be directly connected to a thermocouple, resistance bulb or 4 to 20mA input optionally.

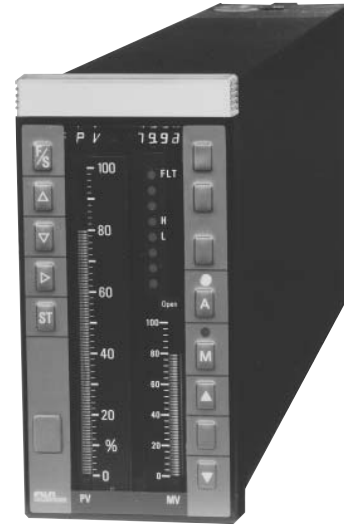

FEATURES

1. High reliability

The manual loader is a solid state instrument having few mechanical parts. The indicator and other units which formerly consisted of mechanical parts are also designed with solid state circuits to provide high reliability.

2. Application of international standards

The instrument is compact, and the external dimensions comply with international IEC. The power supply and signal also comply with IEC standards (24V, 1 to 5V DC). Operation on 100V or 200V AC power supply is possible.

3. Front panel operation

Process values, valve position input, etc. can be read accurately from the digital display on the panel front. Parameter setting and manual operation are also possible from the front of the panel.

FUNCTIONAL DIAGRAM

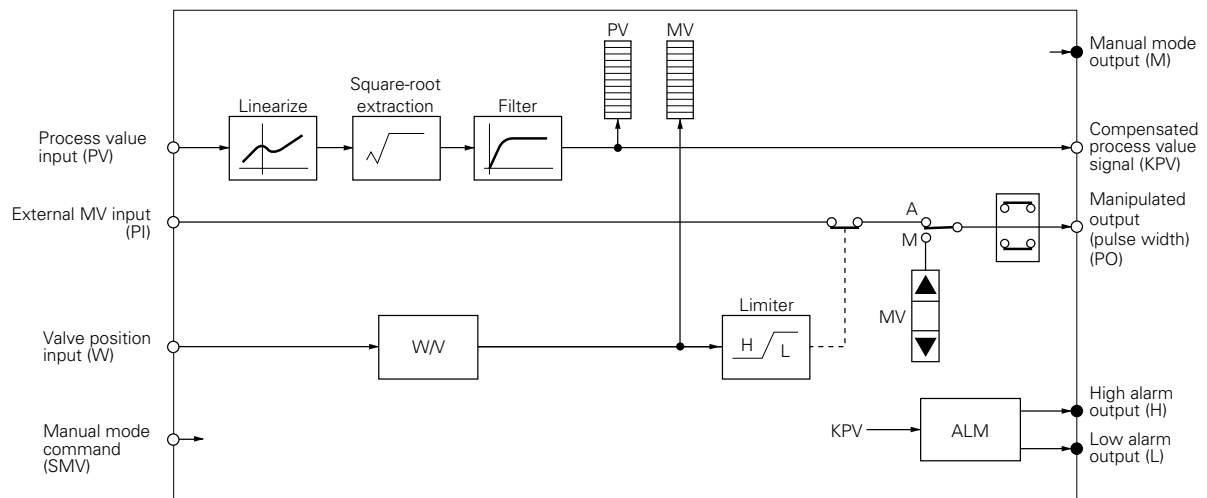

SPECIFICATIONS

1. Input signal

(1) Process value input signal:

One point of signal select from the following inputs

Voltage input signal	1 to 5V DC	Input resistance, more than 1MΩ	Allow. error ±0.2%/FS*
Current input signal	4 to 20mA DC	24V DC power supplied to transmitter during AC operation	Allow. error ±0.2%/FS*
Thermocouple input	Type J:0 to 600°C K:0 to 1200°C E:0 to 800°C R:0 to 1600°C	10mV DC span or more Basic contact compensating function	Allow. error ±0.5%/FS*
Resistance bulb input	JPt100/Pt100 -50 to 500°C	50°C span or more	Allow. error ±0.5%/FS*

Note: * FS: Full scale

(2) Valve position input signal: 1 point

Voltage input signal	W ₀	1 to 5V DC	Input resistance, 1MΩ or more Allow. error ±0.5%/FS*
Resistance input signal	W ₊ W ₀ W ₋	50 to 1000Ω span**	3-wire system potentiometer Allow. error ±0.5%/FS*

Note: ** : Basic design: 10 to 100 to 10Ω, others should be specified.

(3) Pulse width input signal: 1 set

Pulse width input signal	PI+ PI-	Contact input (photo-coupler insulation)	ON 0V, OFF 24V (input current, approx. 11mA/24V DC)
--------------------------	------------	--	---

(4) Digital input signal: 1 point

Manual mode command	SMV	Contact input (photo-coupler insulation)	ON 0V, OFF 24V (input current, approx. 11mA/24V DC)
---------------------	-----	--	---

2. Output signal

(1) Control output signal: 1 set

Pulse width output signal	PO+ PO-	Open-collector output (photo-coupler insulation)	Output rating, 30V x 0.1A DC, max.
---------------------------	------------	--	------------------------------------

(2) Analog output signal: 1 point

Compensated process value signal	KPV	1 to 5V DC	Output resistance, 1Ω or less Allow. error ±0.2%/FS
----------------------------------	-----	------------	--

(3) Digital output signal: 4 points

Fault output	FLT	Open-collector output (photo-coupler insulation)	Output rating, 30V x 0.1A DC, max.
Manual mode output	M		
High alarm output	H		
Low alarm output	L		

3. Indication, setting, operating functions

(1) Bar graph indication

	PV indicator	MV indicator
Indication method	LED (red)	LED (red)
No. of indicating segments	101 + 2	51 + 2
Indication range	0 to 100%, linear	0 to 100%, linear
Indication resolution	1 %/FS	2%/FS
Scale length	100mm	50mm
Indicating mode	0 to 100% bar graph indication, 0 to 100% reverse bar graph indication, 0 to 100% dot indication	

(2) Operation mode indication

Indicating method:

LED (red and green)

Red: M

Green: A

(3) Numerical indication, setting

Indication method:

LED (red), name in 3 digits + number in 5 digits (negative sign included)

Indication contents:

Process variable (engineering unit), high/low alarm, limiter value etc.

Indication contents are select with F/S, Δ, ▽, keys on front panel.

Setting method: By using F/S, Δ, ▽, ▷, ST, keys on front panel

(4) Operating functions

Manual operating method:

By use of ▲, ▼, buttons on front panel

Auto operating method:

By pulse width input signal

(5) Operation mode selection

By using front panel A/M pushbutton

A ↔ M selection	Balanceless bumpless
-----------------	----------------------

(6) Alarm function

High/low limit alarm can be set in engineering units for process value input signal.

4. Power failure processing function

Power failure detection:

Control output OFF at power failure detection.

During power failure:

Data backed up by capacitor when power failure occurs within 5 minutes.

Initial value of data stored in non-volatile memory (last for more than 10 years at ambient temperature of 50°C or less).

Power failure recovery time:

Initial or continuous start set for power failure within 5 minutes.

Recovery from power failure lasting longer than 5 minutes is done by initial.

Note: Control mode at initialization set.

M: Manual mode or A: Auto mode

5. Self-diagnosis functions

Process value input signal abnormality:

FLT indicator lights and FLT contact output turns ON.

Fault contents indication:

Cause of fault is indicated numerically on numerical indicator on the front panel.

6. Other functions

Data protective function by use of pass code

7. Operating conditions

Power supply: Selected from the following 3 types

24V DC (20 to 30V DC)

100V AC (85 to 132V/47 to 63Hz AC)

200V AC (87 to 264V/47 to 63Hz AC)

Power consumption:

Approx. 11W (DC)

Approx. 20VA (AC)

Dielectric strength: 1500V AC, 1 min.
 Insulation resistance: 100MΩ or more at 500V DC
 Ambient temperature: 0 to 50°C
 Ambient humidity: 90% RH or less
 Enclosure: Steel case
 Nameplate: 100 (H) x 72 (W) mm, white acryl
 Dimensions: 144 (H) x 72 (W) x 391 (D) mm, IEC (DIN) standards
 Mass {weight}: Approx. 2.9kg
 Mounting method: Flush with indoor panel; vertical mounting is standard.
 Mounting on tilted surface possible (angle "α")

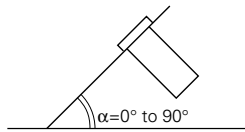

Finish color: Munsell N1.5 for front panel and case
 Range of delivery: Manual loader and mounting bracket

CODE SYMBOLS

1 2 3 4 5 6 7 8 9									Description	
P	N	D	1				5		Process value input signal 1 to 5V DC 4 to 20mA DC J thermocouple K thermocouple E thermocouple R thermocouple Resistance bulb, JPt100, 3-wire, 50°C span or more Resistance bulb, Pt100, 3-wire, 50°C span or more	
A	B	C	D	E	F	G	W			
A	B									Operating method M type A-M type
1	2	3								Power supply 24V DC (20 to 30V DC) 100V AC (85 to 132V/47 to 63Hz AC) 200V AC (187 to 264V/47 to 63Hz AC)
1	2									Valve position input signal Voltage input signal (1 to 5V DC) Resistance input signal (50 to 1000Ω span) (Note 1)

- Notes: (1) Basic: 10 to 100 to 10Ω, others should be specified.
 (2) Symbols of resistance bulbs are as follows.
 JPt100 ... JIS C 1604-1981
 Pt100 ... IEC Pub751-1983
 (JPt/Pt changeover is possible with front key.)

OUTLINE DIAGRAM (Unit:mm)

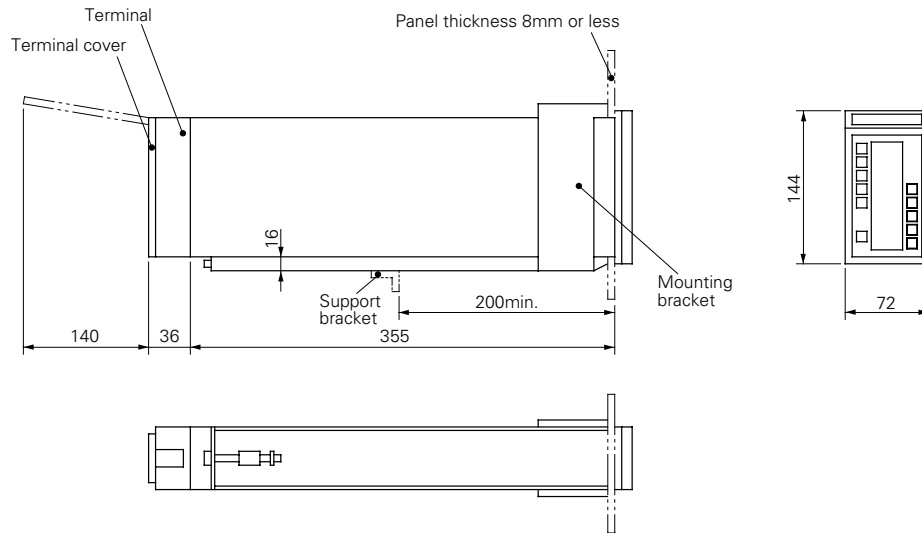

Panel cutout

When mounting one unit

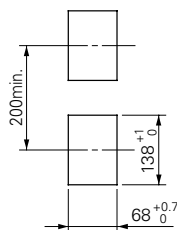

When mounting "n" units

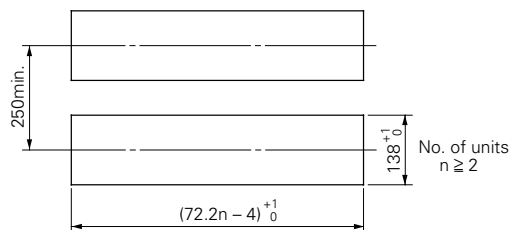

CONNECTION DIAGRAM

Block terminal (M4 screws)

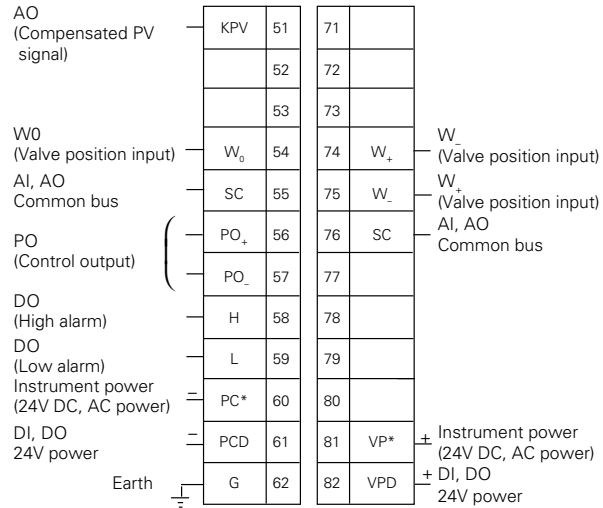
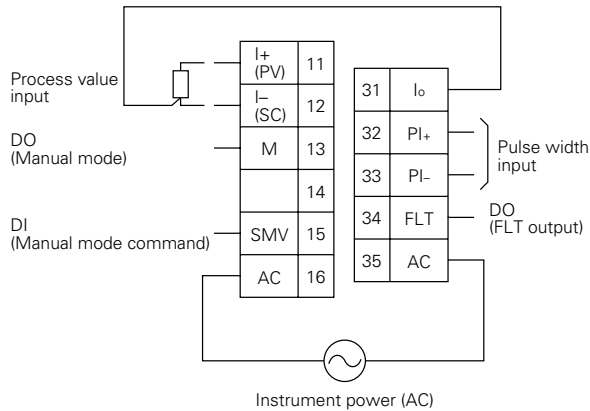

Note: * Symbols for AC instrument power are VPO, PCO.
Output : Approx. 24V DC (0.1A max.)

Process value input terminal connections

<p>1 to 5V DC The 5th digit of code symbols: "A"</p>		<p>Thermocouple The 5th digit of code symbols: C,D,E,F</p>	
<p>4 to 20mA DC The 5th digit of code symbols: "B"</p>		<p>Resistance bulb The 5th digit of code symbols: G,W</p>	
<p>4 to 20mA DC power The 5th digit of code symbols: "B"</p>			

⚠ Caution on Safety

*Before using this product, be sure to read its instruction manual in advance.

Fuji Electric Systems Co., Ltd.

Head Office

6-17, Sanbancho, Chiyoda-ku, Tokyo 102-0075, Japan
http://www.fesys.co.jp/eng

Sales Div.

International Sales Dept.

No.1, Fuji-machi, Hino-city, Tokyo, 191-8502 Japan
Phone: 81-42-585-6201, 6202 Fax: 81-42-585-6187
http://www.fic-net.jp/eng