

FCX SERIES DIFFERENTIAL PRESSURE TRANSMITTER

DATA SHEET

FHC,FKC

The FCX series differential pressure transmitter accurately measures differential pressure, liquid level or gauge pressure and transmits proportional 4 to 20mA signal. The transmitter utilizes the unique micromachined capacitive silicon sensor with state-of-the-art microprocessor technology to provide exceptional performance and functionality.

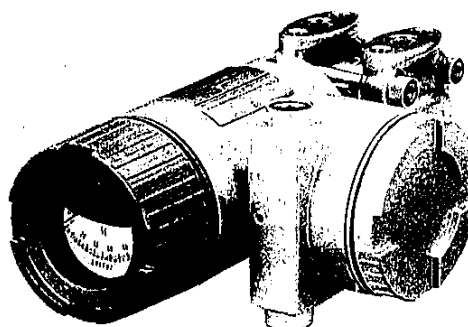

FEATURES

- Outstanding accuracy**
0.1% accuracy for all calibrated spans is the standard feature for all DP models covering 10mbar draft range to 30 bar high differential. Fuji's Micro-capacitance silicon sensor assures this feature for all elevated or suppressed calibration ranges without additional adjustment.
- Minimum environment influence**
Fuji's patented "Advanced Floating Cell" design which protects the pressure sensor against changes in temperature, static pressure, and overpressure substantially reduces total measurement error in actual field applications.
- Smart/Traditional convertible**
Fuji micro-electronics manufacturing technology offers free selection of Smart/Traditional transmitters. A small plug-in communication module upgrades your model FHC to smart type model FKC, which has full remote communication capabilities. A Hand Held Communicator (HHC), model FXW can remotely display or reconfigure all transmitter parameters at any point on the loop without affecting the transmitter signal.
- Application flexibility**
Example features that render the FCX series suitable for almost any process applications includes:
 - Analog indicator at either the electronics side or terminal side
 - Full range of hazardous location approvals
 - Built-in RFI filter and lightning arrester
 - 4-digits LCD meter
 - Stainless steel electronics housing
 - Wide selection of materials

SPECIFICATIONS

Functional specifications

Type:
Model FHC: 4 to 20mA, Traditional type
Model FKC: 4 to 20mA with digital signal, Smart type

Service: Liquid, gas, or vapour

Static pressure, span, and range limit:

Type	Static pressure (kgf/cm ² or bar)	Span limit [mmH ₂ O]			Range limit (mmH ₂ O)
		Minimum		Maximum FHC/FKC	
		FHC	FKC		
F□C□11	-1 to + 32	10	10	100	+/- 100
F□C□12	-1 to + 32	60	10	600	+/- 600
F□C□23	-1 to +100	320	32	3200	+/- 3200
F□C□24	-1 to +100	640	64	6400	+/- 6400
F□C□25	-1 to +100	1300	130	13000	+/- 13000
F□C□26	-1 to +100	5000	500	50000	+/- 50000
F□C□33	-1 to +160*	320	32	3200	+/- 3200
F□C□34	-1 to +160*	640	64	6400	+/- 6400
F□C□35	-1 to +160*	1300	130	13000	+/- 13000
F□C□36	-1 to +160*	5000	500	50000	+/- 50000
F□C□38	-1 to +160*	30000	3000	300000	+/- 300000
F□C□43	-1 to +420	320	32	3200	+/- 3200
F□C□44	-1 to +420	640	64	6400	+/- 6400
F□C□45	-1 to +420	1300	130	13000	+/- 13000
F□C□46	-1 to +420	5000	500	50000	+/- 50000
F□C□47	-1 to +420	20000	2000	200000	+/- 200000

Remark: To minimize environment influence, span should be greater than 1/25 of the max. span in most applications.

- Lower limit of static pressure (vacuum limit) is;
 - Silicone fill sensor: See Fig. 1
 - F□C 38 and F□C 47: -0.5kg/cm^2
 - Fluorinated fill sensor: 660 mbar or 500mmHg abs at temperature below 60°C .
 - The maximum span of each sensor can be converted to in different units using below factors.
 - 1 bar = $1\text{kgf/cm}^2 = 0.1\text{MPa} = 14.5038\text{psi}$
 - 10 mmH₂O = 1 mbar = 0.1 kPa = 0.3937 in H₂O
- Note: *100kgf/cm² if stainless steel bolts and nuts are specified.

Overrange limit: To maximum static pressure limit

Output signal:

- Model FHC: 4 to 20mA DC 2-wire, linear signal
- Model FKC: 4 to 20mA DC (linear or square root) with digital signal superimposed on the 4 to 20mA signal.

Power supply: Transmitter operates on 11V to 45V DC at transmitter terminals.
11V to 27V DC for the units with optional arrester.

Load limitations: see figure below

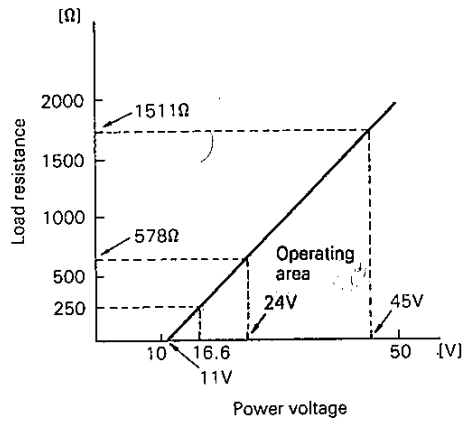

Note: For communication with FXW, min. of 250Ω required.

Hazardous locations:
Designed to meet international intrinsic safety and flameproof (explosionproof) standards.
Consult Fuji for certification status.

Authorities	Flameproof	Intrinsic safety	Type N Nonincendive
BASEEFA	Ex ds IIC T5, T6	EEx ia IIC T4, T5	Ex N II T5
PTB	—	EEx ib IIC T4, T5	—
Factory Mutual	Class I II III Div. 1 Groups B thru. G	Class I II III Div. 1 Groups A thru. G	Class I II III Div. 2 Groups A thru. G
CSA	Class I II III Div. 1 Groups C thru. G	Class I II III Div. 1 Groups A thru. G	Class I II III Div. 2 Groups A thru. G
RIIS	ds2G4	i3aG4	—
SAA	Exd IIB T6 IP67	Ex ia IIC T5, T6	—

Remark: Approval pending.

- Zero/span adjustment:**
- Model FHC: Zero is adjustable externally from the push buttons (UP and DOWN). The push buttons can also function to adjust span when MODE SWITCH (located on the front face of electronics unit) is in the span mode. INHIBIT mode to disable the push buttons is also available.
 - Model FKC: Zero and span are adjustable either from the HHC or by the external push buttons. (one-push function)
- Damping:** Adjustable electrical damping.
- Model FHC: The time constant is adjustable to 0, 0.3, 1.2, 4.8, or 19.2 seconds.
 - Model FKC: The time constant is adjustable between 0 to 38.4 seconds.
- Zero elevation/suppression:** -100% to +100% of URL
- Normal/reverse action:**
- Model FHC: Selectable by moving a jumper pin located on the electronics unit.
 - Model FKC: Selectable from HHC
- Indication:** Analog indicator or 4-digit LCD meter, as specified.
- Burnout direction:** Output hold
Output 21.6mA } selectable
Output 3.8mA }
- Model FHC: Unless otherwise specified, the burnout is in hold position.
 - Model FKC: Selectable from HHC
- Loop-check output:**
- Model FHC: Transmitter can output constant signal of 4mA, 12mA, or 20mA if MODE SWITCH is set to the loop check mode.
 - Model FKC: Transmitter can be configured to provide constant signal 4mA or 20mA by HHC.
- Temperature limit:** Ambient: -40 to +85°C
(-20 to +80°C for LCD indicator)
(-40 to +60°C for arrester option)
(-10 to +60°C for fluorinated oil filled transmitters)
For explosionproof units (flameproof or intrinsic safety), ambient temperature must be within the limits specified in each standard.
Process: -40 to +120°C for silicone fill sensor.
-20 to +120°C for fluorinated oil fill sensor
Storage: -40 to +90°C
- Humidity limit:** 0 to 100% RH

Communication: (Model FKC only)

With HHC (Model FXW, consult Data Sheet No. EDS8-47), following information can be remotely displayed or reconfigured.

Items	Display	Set
Tag No.	v	v
Model No.	v	v
Serial No.	v	—
Engineering unit	v	v
Range limit	v	—
Measuring range	v	v
Damping	v	v
Output mode	v	v
Burnout direction	v	v
Adjustment	v	v
Output adjust	—	v
Data	v	—
Self diagnoses	v	—
Printer	—	—
External switch lock	v	v

Performance specifications

Accuracy rating: (including linearity, hysteresis, and repeatability)

For spans greater than 1/10 of URL: 0.1% of span

For spans below 1/10 of URL (Model FKC only):

$$\pm \left(0.05 + 0.05 \frac{0.1 \times \text{URL}}{\text{Span}} \right) \% \text{ of span}$$

Linearity: 0.05% of calibrated span

Stability: ±0.1% of upper range limit (URL) for 6 months

Temperature effect:

Effects per 55°C change between the limits of -40°C and +85°C

Range code (6th digit in Code symbols)	Zero shift (% of URL)	Total effect (% of URL)
"1"/ 100 mmH ₂ O max. span	±0.5% / 55°C	±0.8% / 55°C
"2"/ 600 mmH ₂ O max. span		
"3"/ 3.2 mH ₂ O max. span	±0.25% / 55°C	±0.5% / 55°C
"4"/ 6.4 mH ₂ O max. span		
"5"/ 13 mH ₂ O max. span		
"6"/ 50 mH ₂ O max. span		
"7"/ 200 mH ₂ O max. span		
"8"/ 300 mH ₂ O max. span		

Static pressure effect:

Static pressure code (5th digit in Code symbols)	Zero shift (% of URL)	Span shift (% of calibrated span)
"1"/ 100mmH ₂ O sensor	±0.2% / 10 bar	-0.2% / 32 bar
"1"/ 600mmH ₂ O sensor	±0.2% / 32 bar	-0.2% / 32 bar
"2"	±0.1% / 100 bar	-0.2% / 100 bar
"3"		
"4"		

Double the Zero shift for material code (7th digit in Code symbols) "H", "M", "T", "B", "L" and "U".

Overrange effect: Zero shift, % of URL

Static pressure code (5th digit in Code symbols)	Zero shift (% of URL)
"1"/ 100mmH ₂ O sensor	±0.3% / 10 bar
"1"/ 600mmH ₂ O sensor	±0.3% / 32 bar
"2"	±0.3% / 100 bar
"3"	±0.3% / 160 bar
"4"	±0.5% / 420 bar

Double the effects for material code "H", "M", "T", "B", "L" and "U".

Supply voltage effect:

Less than 0.05% of calibrated span per 10V

RFI effect:

Less than 0.2% of URL for the frequencies of 20 to 1000MHz and field strength 10 V/m when electronics covers on.

(Classification: 2-abc: 0.2% span per SAMA PMC 33.1)

Step response: (without electrical damping)

Range code	Time constant	Dead time
"1"	1.25 s	approx. 0.3 s
"2"	0.85 s	
"3"	0.45 s	
"4" through "8"	0.2 s	

Mounting position effect:

Zero shift, less than 12mmH₂O for a 10° tilt in any plane.

No effect on span.

This error can be corrected by adjusting Zero.

(Double the effect for fluorinated fill sensors)

Dielectric strength:

500V AC, 50/60Hz 1 min., between circuit and earth (For the type with arrester, remove earthing plate.)

Insulation resistance:

More than 100MΩ at 500V DC (For the type with arrester, remove earthing plate.)

Turn-on time: 4 sec.

Performance specifications for square root output: (Model FKC only)

Accuracy rating:

Output	Span	
	over 0.1 × URL	below 0.1 × URL
50 to 100%	±0.1 %	±(0.05 + 0.05 × 0.1 × URL/Span)
20 to 50%	±0.25%	±2.5 × (0.05 + 0.05 × 0.1 × URL/Span)
10 to 20%	±0.5 %	±5 × (0.05 + 0.05 × 0.1 × URL/Span)

Temperature effect:

Effect per 55°C change between the limits of -40°C and +85°C (% of URL)

Range code	Shift at 20% output point
"1" and "2"	±1.5% / 55°C
"3" through "8"	±0.7% / 55°C

Low flow cut-off:

Customer configurable for any point between 7 to 20% of output

Physical specifications

Electrical connections:

G1/2, 1/2-14 NPT, Pg13.5, or M20 × 1.5 conduit, as specified.

Process connections:

1/4-18 NPT or Rc1/4 on 54mm centers, as specified.

Meets DIN 19213.

Process-wetted parts material:

Material code (7th figure in MODEL CODE)	Process cover	Diaphragm	Wetted sensor body	Vent/drain
W	316 SS	Hastelloy-C	316 SS	316 SS
E	CS	Hastelloy-C	316 SS	316 SS
H	316 SS	Hastelloy-C	Hastelloy-C lining	316 SS
M	316 SS	Monel	Monel lining	316 SS
T	316 SS	Tantalum	Tantalum lining	316 SS
B	Hastelloy-C lining	Hastelloy-C	Hastelloy-C lining	Hastelloy-C
L	Monel lining	Monel	Monel lining	Monel
U	Tantalum lining	Tantalum	Tantalum lining	Tantalum

Sensor O-rings: Viton for material code "W", "E", "H", "M", and "T"
 Teflon for material code "B", "L", and "U"

Availability of above material design depends on ranges and static pressure. Refer to "Code symbols".

Non-wetted parts material:

Electronics housing: Low copper die-cast aluminum alloy (standard), finished with epoxy/polyurethane double coating, or 304 SS, as specified.

Bolts and nuts: Cr-Mo alloy (standard), 304 SS (for static pressure code "1", "2", and "3" only), or 630 SS (for static pressure code "4" only). Static pressure rating for code "3" with 304 SS bolts is degraded to 100 bar.

Fill fluid: Silicone oil (standard) or fluorinated oil (Daifloil)

Mounting bracket: Carbon steel with epoxy coating or 304 SS, as specified

Environmental protection:

IEC IP67 and NEMA 4X

Mounting:

On 50mm (50A or 2 inches) pipe using mounting bracket, direct wall mounting, or direct process mounting.

Weight:

Transmitter approximately 5kg without options.
 Add; 0.5kg for mounting bracket
 0.8kg for indicator option
 4.5kg for stainless steel housing option

Optional features

Indicator:

A plug-in turnable analog indicator (1.5% accuracy) can be housed in the electronics compartment or in the terminal box of the housing.
 An optional 4 digits LCD meter is also available.

Arrester:

A built-in arrester protects the electronics from lightning surges.
 Not available with intrinsic safety approvals.

Oxygen service:

Special cleaning procedures are followed throughout the process to maintain all process wetted parts oil-free.
 The fill fluid is fluorinated oil. A carbon steel cover is not available for oxygen service.

Chlorine service: Oil-free procedures as above. Includes fluorinated oil for fill.
 Not available with material code "E" and "W".

Degreasing:

Process-wetted parts are cleaned, but the fill fluid is standard silicone oil. Not for use for oxygen or chlorine measurement.

NACE specification:

Metallic materials for all pressure boundary parts comply with NACE MR-01-75. Includes ASTM B7M or L7M bolts and 2HM nuts. (Class II)
 Static pressure rating for code "3" (160 bar) is degraded to 100 bar.

Vacuum service:

Special silicone oil and filling procedure are applied.
 See below figure.

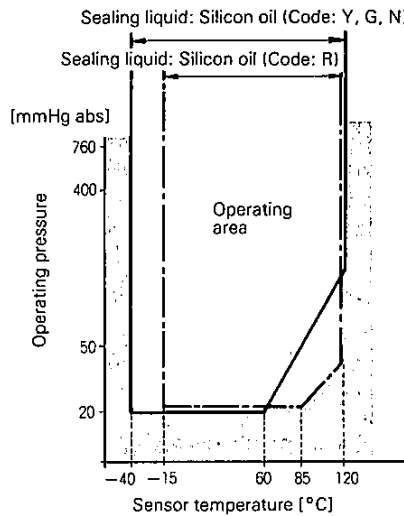

Fig. 1 Relation between sensor temperature and operating pressure

Customer tag:

A stainless steel tag with customer tag data is wired to the transmitter.

ACCESSORIES

Oval flanges:

(Model FFP, refer to Data Sheet No. EDS6-10)
 Converts process connection to 1/2-14 NPT or to Rc 1/2; in carbon steel or in 316 SS.

Three-value manifolds:

(Model FFN, refer to Data Sheet No. EDS6-10)
 Available in CS or in 316SS and in pressure rating 160bar or 420bar.

Hand held communicator:

Model FXW, refer to Data Sheet No. EDS 8-47

Communication module: (Standard for model FKC)

When using this module for model FHC, remote setting function becomes available.

Remark: When the communication module is connected, the operation mode of external zero/span is changed from UP-DOWN to one-push adjustment.

OUTLINE DIAGRAM (Unit:mm)

<Models with CS or SS process covers>

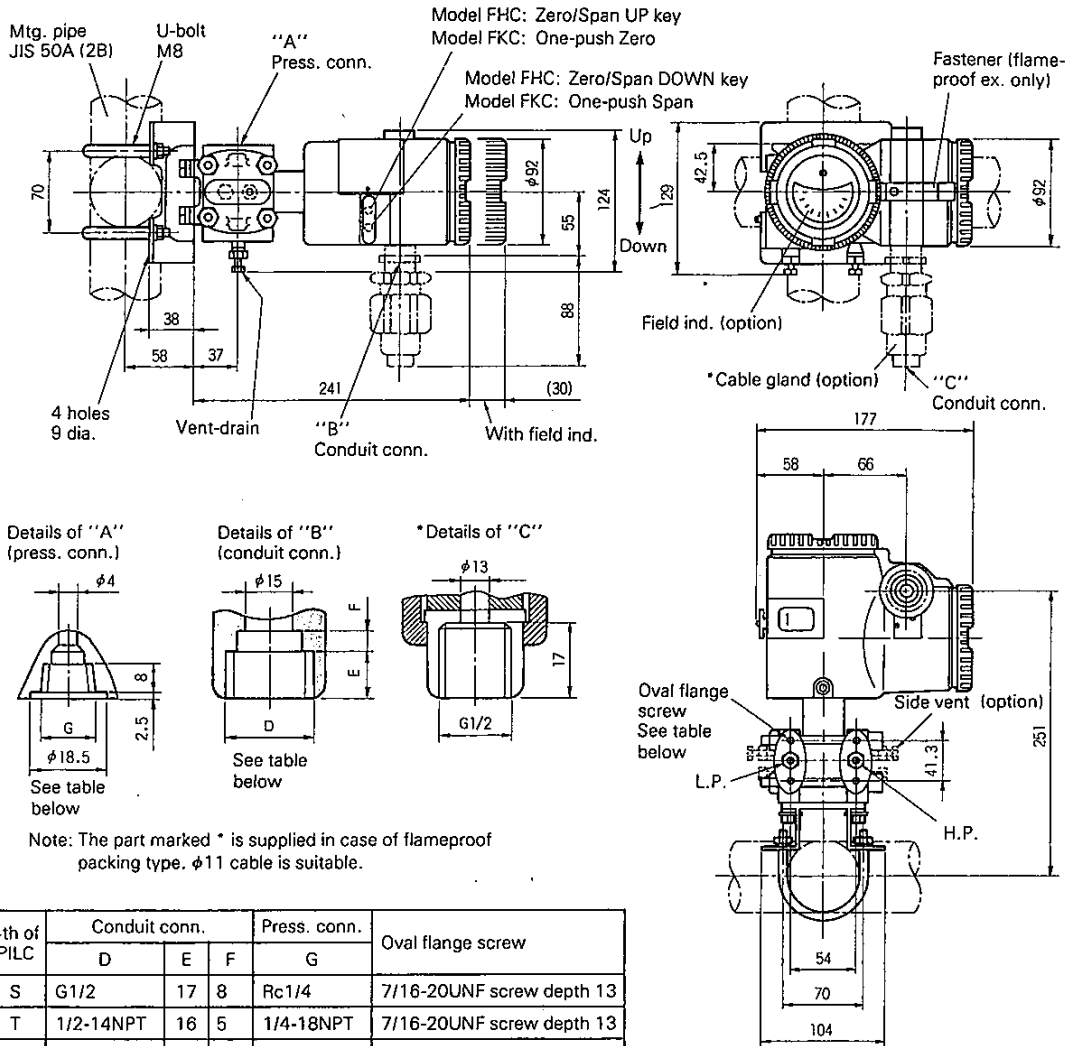

Note: The part marked * is supplied in case of flameproof packing type. $\phi 11$ cable is suitable.

4th of PILC	Conduit conn.			Press. conn.	Oval flange screw
	D	E	F	G	
S	G1/2	17	8	Rc1/4	7/16-20UNF screw depth 13
T	1/2-14NPT	16	5	1/4-18NPT	7/16-20UNF screw depth 13
V	Pg13.5	8	4.5	1/4-18NPT	M10 or M12 screw depth 13
W	M20 x 1.5	16	5	1/4-18NPT	M10 or M12 screw depth 13
X	Pg13.5	8	4.5	1/4-18NPT	7/16-20UNF screw depth 13

< Optional stainless steel tag >

CONNECTION DIAGRAM

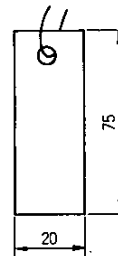
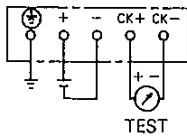

1	2	3	4	5	6	7	8	9	10	11	12	13
F	H	C					1					
F	K	C					1					

		Description		
		Indicator and arrester		
		Indicator	Arrester(*)	
A	-----	None	None	
B	-----	Analog, 0 to 100% linear scale	None	
C	-----	Analog, 0 to 100% sq. root scale	None	
D	-----	Analog, custom scale	None	
E	-----	None	Yes	
F	-----	Analog, 0 to 100% linear scale	Yes	
G	-----	Analog, 0 to 100% sq. root scale	Yes	
H	-----	Analog, custom scale	Yes	
L	-----	Digital, 0 to 100%	None	
P	-----	Digital, custom scale	None (Model FKC only)	
Q	-----	Digital, 0 to 100%	Yes	
S	-----	Digital, custom scale	Yes (Model FKC only)	
		Approvals for hazardous locations (Approvals pending. Consult Fuji for status)		
A	-----	None (for ordinary locations)		
B	-----	JIS, Flameproof (Conduit seal)		
C	-----	JIS, Flameproof (Cable grand seal)		
D	-----	FM, Flameproof (or explosionproof)		
E	-----	CSA, Flameproof (or explosionproof)		
M	-----	BASEEFA, Flameproof (Conduit seal)		
N	-----	BASEEFA, Flameproof (Cable grand seal) (Conduit connection G1/2 only)		
R	-----	SAA, Flameproof (Conduit seal)		
S	-----	SAA, Flameproof (Cable grand seal) (Conduit connection G1/2 only)		
G	-----	JIS, Intrinsic safety		
H	-----	FM, Intrinsic safety and Nonincendive		
J	-----	CSA, Intrinsic safety and Nonincendive		
K	-----	BASEEFA, Intrinsic safety		
P	-----	BASEEFA, Type N		
L	-----	PTB, Intrinsic safety		
T	-----	SAA, Intrinsic safety		
		Side vent/drain and mounting bracket		
		Side vent/drain	Mounting bracket	
A	-----	None	None	
B	-----	None	Yes, CS	
C	-----	None	Yes, stainless steel	
D	-----	Yes	None	
E	-----	Yes	Yes, CS	
F	-----	Yes	Yes, stainless steel	
		Stainless steel parts		
		SS bolt/nut	SS tag plate	SS elec. housing
Y	-----	None	None	None
A	-----	Yes	None	None
B	-----	None	Yes	None
C	-----	None	None	Yes
D	-----	Yes	Yes	None
E	-----	None	Yes	Yes
F	-----	Yes	None	Yes
G	-----	Yes	Yes	Yes
		Special applications and fill fluid		
		Treatment	Fill fluid	
Y	-----	None (standard)	Silicone oil	
W	-----	None (standard)	Fluorinated oil	
G	-----	Degreasing	Silicone oil	
A	-----	Oxygen service	Fluorinated oil (Material code "W" only)	
D	-----	Chlorine service	Fluorinated oil (Material code "H", "T", "B", "U")	
N	-----	NACE specification	Silicone oil	
R	-----	Vacuum service	Silicone oil for vacuum use	

Note: Arrester option is not available when intrinsic safety is specified.

OUTLINE DIAGRAM (Unit:mm)

<Models with special material process covers>

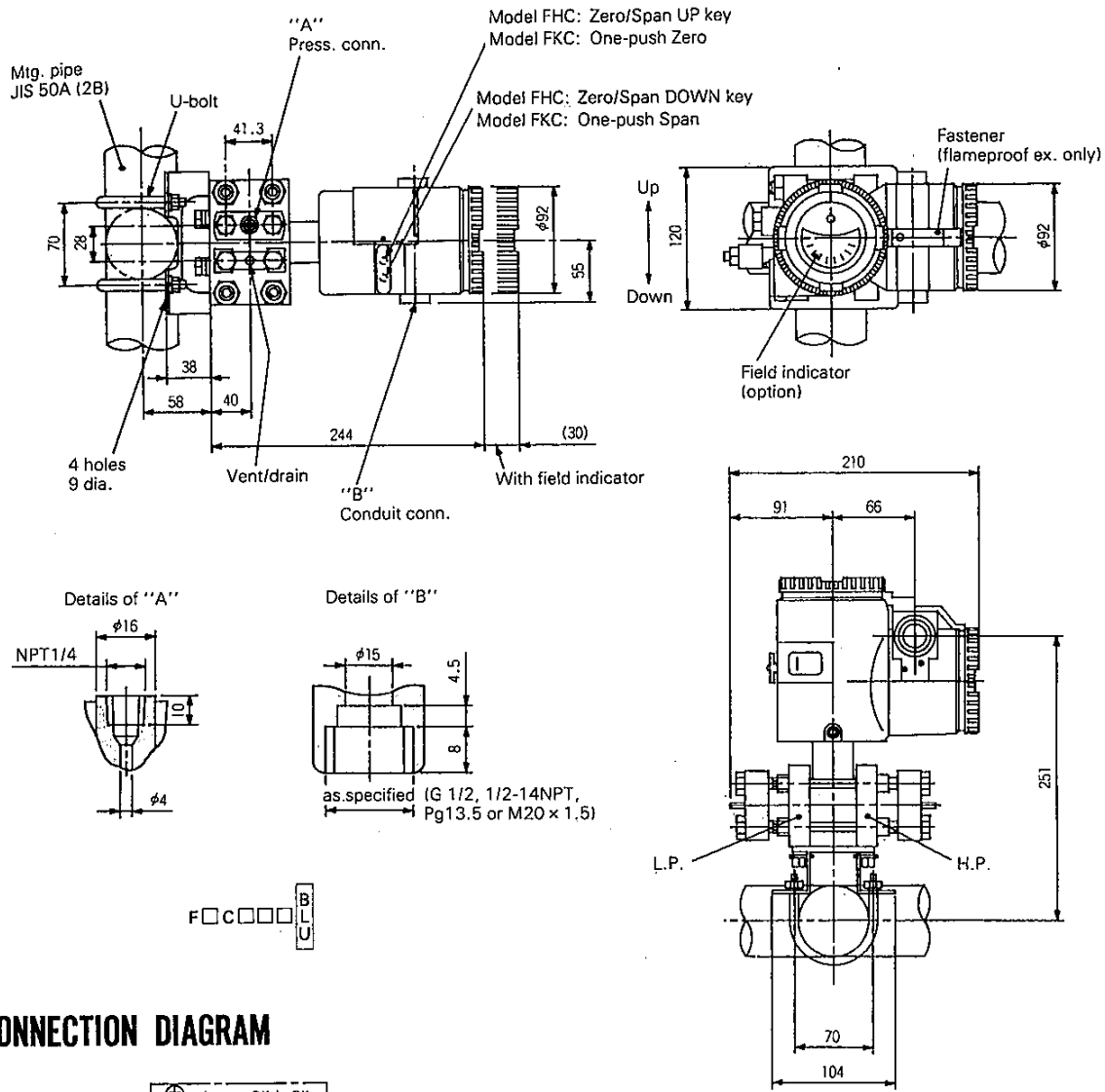

CONNECTION DIAGRAM

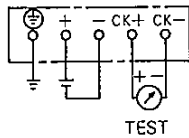

< Optional stainless steel tag >

