

E SERIESE ELECTROMAGNETIC FLOWMETER (SEPARATE TYPE)

DATA SHEET

FMF1,2/FMH

The electromagnetic flowmeter is an instrument to measure the volumetric flow rate of liquid simply by applying a magnetic field from the outside utilizing the fact that an electric conductor which crosses a magnetic field at a certain velocity causes voltage to be induced in proportion to the velocity, which is known as Faraday's law.

This flowmeter is designed with the latest electronics technology, realizing a compact and light-weight structure and measurement with high accuracy.

FEATURES

1. High accuracy
When conductivity is above 5 $\mu\text{S}/\text{cm}$, flow rate of liquid can be measured regardless of density and viscosity. The measurement accuracy is as high as 0.6% of rate.
2. Free power supply
The flowmeter operates on power supply 100 to 230V AC, 50/60Hz.
3. Grounding electrode
Use of the grounding electrode of Hasteroy C in the flowmeter allows installation without an earth ring.
4. Change of settings.
The setting of various parameters can be changed from the outside of the case cover. Application of the supplied magnetic stick to the outside glass surface enables the setting to change without opening the case cover.
5. Stable measurement of flow rate
A digital filter for pulsating or noisy flow signal, flow rate output low cut, and damping function allows flow rate measurement to be stabilized.
6. Self-diagnosis function
Since self-diagnosis function is provided for empty detection, trouble, and maloperation, the flowmeter can be used with safety.
7. Simultaneous display of instantaneous flow and total flow 2-stage display with LCD backlight which is visible in the dark.



• Mounting method :

Mounted via flange insertion type on opposite (with Guide rings)

... 3A to 100A

Note 1) Guide ring : A ring-shaped guide used for centering the sensor when a wafer type is mounted on the piping.

Note 2) Flange with meter size 3A or 6A can be used for 15A.

or flange mounting

... 15A to 300A

• Fluid pressure :

0 to 2000kPa or flange operating pressure, whichever is lower.

• Meter size and measurement range

See the following table for the full scale of measurable flow rate.

Meter size	Min.measurement range [m ³ /h]	Max. measurement range [m ³ /h]
3A Note 3)	0 to 0.012	0 to 0.24
6A Note 3)	0 to 0.06	0 to 1.2
15A	0 to 0.3	0 to 6.0
25A	0 to 0.6	0 to 12.0
40A	0 to 1.8	0 to 36.0
50A	0 to 3.0	0 to 60.0
80A	0 to 9.0	0 to 180.0
100A	0 to 12.0	0 to 240.0
150A Note 4)	0 to 30.0	0 to 600.0
200A Note 4)	0 to 54.0	0 to 1080
250A Note 4)	0 to 90.0	0 to 1800
300A Note 4)	0 to 120.0	0 to 2400

Note 3) Meter size 3A and 6A : Wafer type only

Note 4) Meter size 150A or more : Flange type only

SPECIFICATIONS

Detector (Model: FMF)

• Measurement item :

General-use industrial water, waste water, and other liquids with conductivity of more than 5 $\mu\text{S}/\text{cm}$.

• Structure :

Wafer type or flange type

- Fluid temperature :
-25 to +130°C (PFA, TFE lining)

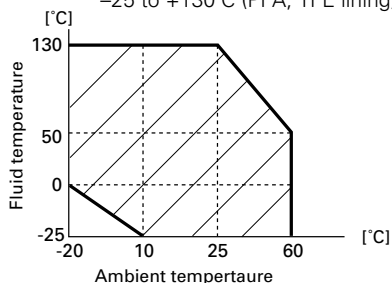

Ambient temperature – fluid temperature allowable range

- Material :

Fluid wetted parts (Note 1)	Lining	Tefron(PFA, TFE)
	Signal electrode Earth electrode Earth ring (Note 2)	Hasteroy C-4 equivalent
Housing case	Aluminum alloy	
Flange (Note 3)	SUS316 equivalent	
Case of terminal box	Aluminum alloy	

Note 1) Materials of fluid wetted parts should be selected in consideration of erosion due to measuring fluid. Refer to the table of material selection on the attached sheet.

Note 2) For earth ring attachments, see CODE SYMBOLS.

Note 3) Flange type only

- Wiring connection port :
G1/2
- Finish color : Silver, LidBeige
- Protection class :
IP67
- Grounding : D-class grounding (100Ω or less)

Converter (Model: FMH)

- Mounting method :
Mounting on the pipe or wall
- Input/output signal :
Current output; 4 to 20mA DC
Load resistance 0 to 600Ω
Pulse output; open-collector
Capacity; 16 to 30V DC, 0.22A or less
ON voltage; 2V or less
Max. 5kHz
Status output; open-collector
Capacity: 16 to 30V DC, 0.22A or less
ON voltage; 2V or less
Status input; voltage input
Capacity: 16 to 30V DC
Internal resistance: 2kΩ
- Pulse output : Total pulses are outputted by setting total constant. Pulse width 0.1 to 2000ms is settable.
- Span setting : Flow rate full scale(FS) can be set by setting flow rate unit and flow rate value.
Display cubic volume; m³, L, mL
Display time unit ; /d, /h, /min, /s
- Flow direction change :
Flow direction can be reversed in flow direction mode.
- Flow display : Real unit flow display, % display or user unit display is possible. Max 6 disits.
- Total display : Totalled volume can be displayed by setting the unit of cubic volume.
Displayed cubic volume unit ; m³, L, mL
Totalled value is held when power failure occurs.

- Fault diagnosis function :
Various faults can be diagnosed by hardware check and process check.
- Zero point adjustment :
Zero point is automatically calibrated with key operation.
- Low cut : 0 to 10% FS settable
Momentary output can be cut to 0% at flow rate below the set cutoff point.
(Note) Output low cut and total low cut are set at the same value.
- 0% signal lock :
Display and output can be locked to 0% with status input.
- Filter :
A digital filter is included in the converter especially for pulsating or noisy flow signals.
- Empty detection :
Absence of liquid is detected and status signal is outputted only when diameter is more than 10A and conductivity is more than 20μS/cm.
- Flow switch : 0 to 130% FS
Status signal is outputted by setting high/low limit flow.
- Dumping time constant :
1 to 99.999 sec
- Density setting :
Available from 0.01 to 5.00g/cm³, and the weight of the fluid can also be indicated.
- Converter case :
Aluminum alloy
- Wiring connection port :
G1/2 (with water-proof gland)
- Finish color : Silver, LidBeige
- Protection class :
IP67
- Grounding : D-class grounding (100Ω or less)
- Mass : 4.5kg
- Length of exclusive signal cable :
50m or less

Other specifications

For different materials of the electrode and earth-ring, contact with Fuji Electric.

Standard performance

- Accuracy rating of display and pulse output :

Flow velocity	Accuracy
0.7m/s or more	±0.5% of rate
0.7m/s or less	$\pm \left(\frac{0.0035}{Q_v} \times 100 \right)$ % of rate

Q_v : Measuring flow velocity

- Accuracy rating of analog output :

Flow velocity	Accuracy
0.7m/s or more	±0.6% of rate
0.7m/s or less	$\pm \left(\frac{0.0035}{Q_v} \times 100 + 0.1 \right)$ % of rate

Q_v : Measuring flow velocity

- Power consumption :
14VA or less
- Operating condition :
Ambient temperature;
-25 to 60°C (Detector ; PFA, TFE lining)
-20 to 60°C (Converter)
Ambient humidity; 95% RH or less (Note)
Power voltage; 100 to 230V AC +10%,
-15%
Power frequency; 50/60Hz
(Note)
If ambient humidity exceeds 95% RH, select a submersible type in FMB model.

Length of straight pipe for installing the electromagnetic flowmeter

The length of the up-stream/down-stream straight pipe of the flowmeter should be long enough to ensure accurate measurements. See below.

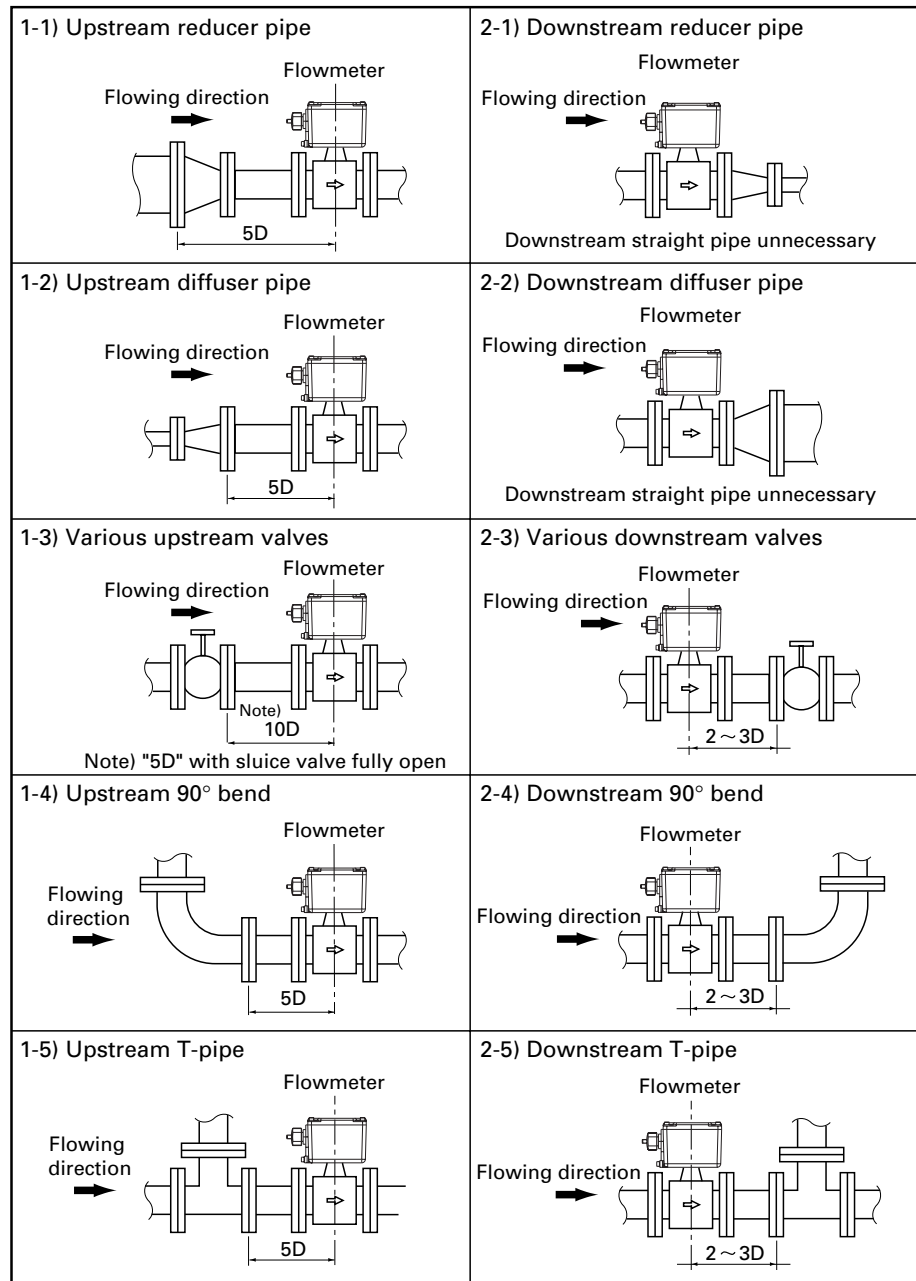

Minimum length of straight pipe between up-stream/down-stream joints and flowmeter.

Note 1) D=diameter of measuring pipe.

Note 2) Do not put any objects, which affect magnetic field, electromotive force and flow velocity profile, in the measuring pipe.

Note 3) Use a straight pipe (2D to 3D) on the down-stream side, if the drift to the up-stream side is affected by installing valves, etc.

Mounting posture of electromagnetic flowmeter

The flowmeter can be installed vertically, horizontally, or at other angle. When installing, be sure to observe the following points.

- ① The measuring pipe should always fill with fluid which flows in the piping.

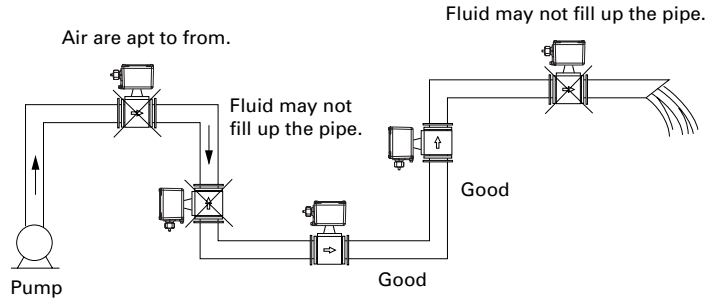

Example of mounting posture

- ② The signal electrode should be at a level with the ground. And also signal electrode and ground electrode should always keep contact with fluid. If the signal electrode or the ground electrode is upper position against the fluid, correct measurements cannot be expected due to air bubbles on the fluid.

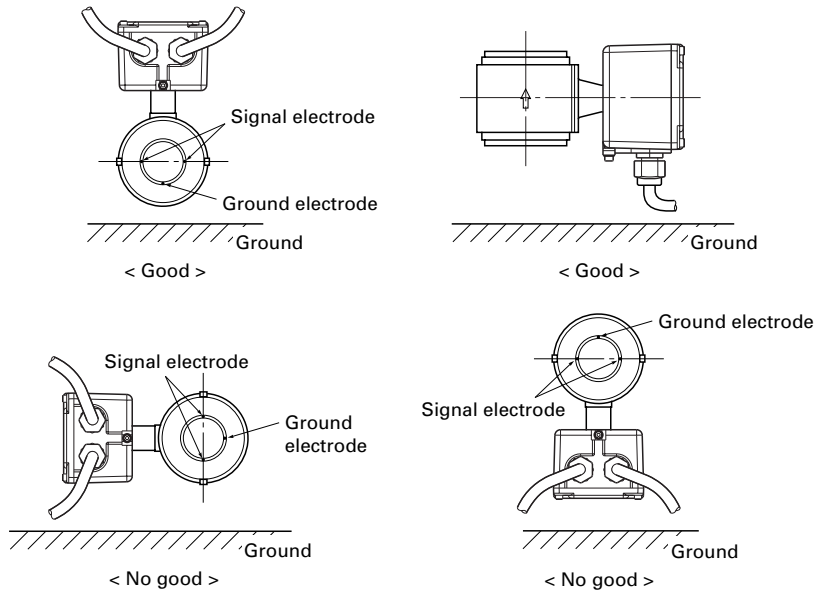

Position of electrode

How to connect the grounding cable contacting with measuring liquid.

Since the electromagnetic flowmeter is provided with a grounding electrode, flow rate of liquid can be measured without an earth ring. However, if stray potential exists in a pipeline, the potential in the pipeline may fluctuate.

In this case, the earth ring (option) of the same material as signal electrode and ground electrode should be mounted on the upstream and downstream sides of the flowmeter to connect to the grounding terminal.

For liquid that contains attachments or deposits, take the liquid contacting ground from the optional earth rings and metallic pipe (without lining).

Grounding connection

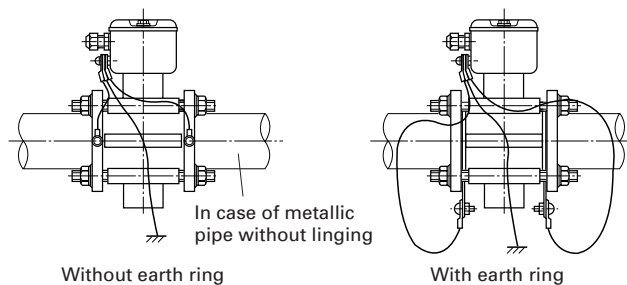

CODE SYMBOLS

Separate type electromagnetic flowmeter Detector (wafer type)

1 2 3 4 5 6 7 8 9 10 11 12 13 14														Description	
F	M	F	1					1	H	0	A	0			Meter size (5th code) 3A * 6A * 15A 25A 40A 50A 80A 100A
S															Lining material (6th code) TFE (adhesive Tefron) : applied for meter size 15A to 100A PFA (mold Tefron) : applied for meter size 3A to 6A *
A															Earth ring material (7th code) None Hasteroy C
C															Electrode material (9th code) Hasteroy C
D															Flange (10th code) None
T															Guide ring (11th code) For JIS 10K For JIS 75M * (Meter size 80A, 100A only)
E															Wiring connection port size (12th code) G1/2(PF1/2) female screw with water-proof gland
F															Application (13th code) Standard
G															Optional specifications (14th code) Y-- None A-- Stainless tag plate

Note 1) Items with the asterisk mark * will be manufactured as order.

Separate type electromagnetic flowmeter Detector (flange type)

1	2	3	4	5	6	7	8	9	10	11	12	13	14	Description
FMF	2													
														Meter size (5th code)
C														15A *
D														25A *
T														40A *
E														50A *
F														80A *
G														100A *
H														150A
J														200A
K														250A *
L														300A *
														Lining material (6th code)
														TFE (adhesive Tefron)
														Earth ring material (7th code)
														None
														Hasteroy C
														Electrode material (9th code)
														Hasteroy C
														Flange (10th code)
														For JIS 10K
														Guide ring (11th code)
														None
														Wiring connection port size (12th code)
														G1/2(PF1/2) female screw with water-proof gland
														Application (13th code)
														Standard
														Optional specifications (14th code)
														None
														Stainless tag plate

Note 1) Items with the asterisk mark * will be manufactured as order.

Separate type electromagnetic flowmeter Converter

1	2	3	4	5	6	7	8	9	10	11	12	13	Description
FMH	1	N	A	1									
													Application (4th digit)
													Standard
													Power supply (5th digit)
													AC100 ~ 230V
													Mounting method (6th digit)
													Pipe mount
													Wall mount
													Wiring lead-in port (7th digit)
													G1/2(PF1/2) female, with water-proof gland
													Optional specification (9th digit)
													None
													With parameter setting function
													Cable termination (10th digit)
													None
													Cable length (11 to 13th digit)
													Nothing
													10m
													20m
													30m
													40m
													50m

OUTLINE DIAGRAM (Unit: mm)

(Wafer type detector)

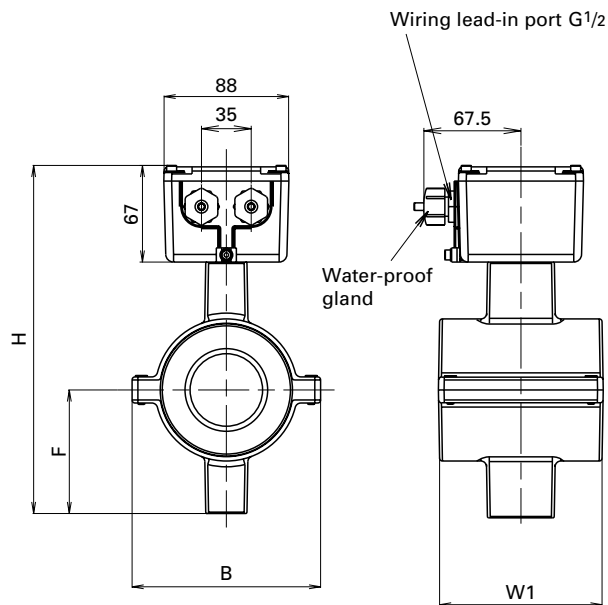

< Stainless tag >

Option

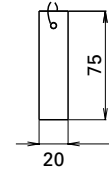

Meter size	3A,6A	15A	25A	40A	50A	80A	100A
W1	69	69	91	104	119	103	133
B	75	75	95	112	130	163	190
F	62	62	73	82	90	110	130
H	191	191	213	231	247	287	327
Mass (Kg)	2	2	3.5	5	5.5	8	9

(Flange type detector)

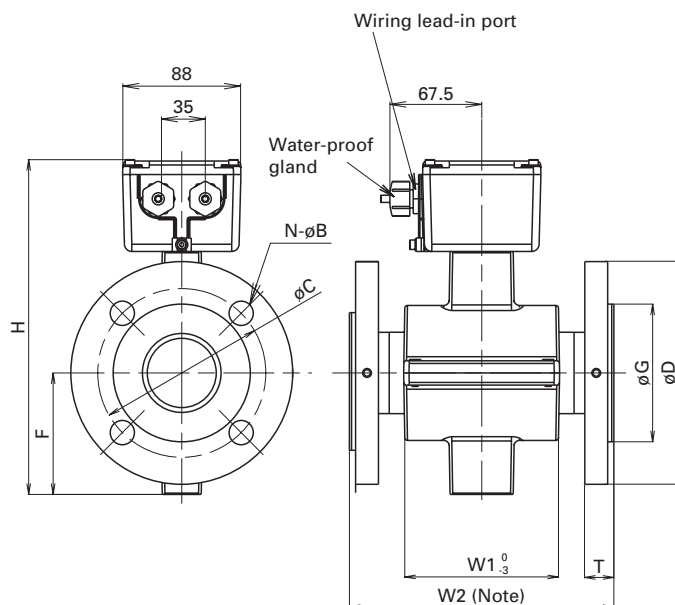

< Stainless tag >

Option

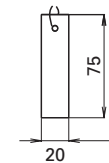

Meter size	15A	25A	40A	50A	80A	100A	
W1	66.5	87	100	116	100	130	
W2	200	200	200	200	200	250	
JIS 10K flange	øD	95	125	140	155	210	
	øC	70	90	105	120	175	
	N-øB	4-12	4-15	4-15	4-19	8-19	8-19
	T	14	18	20	20	20	22
	øG	52	70	85	100	130	155
	H	191	213	231	247	287	327
	F	62	73	82	90	110	130
Mass (Kg)	3	4	6	8	16	17	

(Note) W2 are dimensions after positioning to piping.
The lining flare sections are not glued before positioning to piping
(There are about 30mm protruding of each side.)

OUTLINE DIAGRAM (Unit: mm)

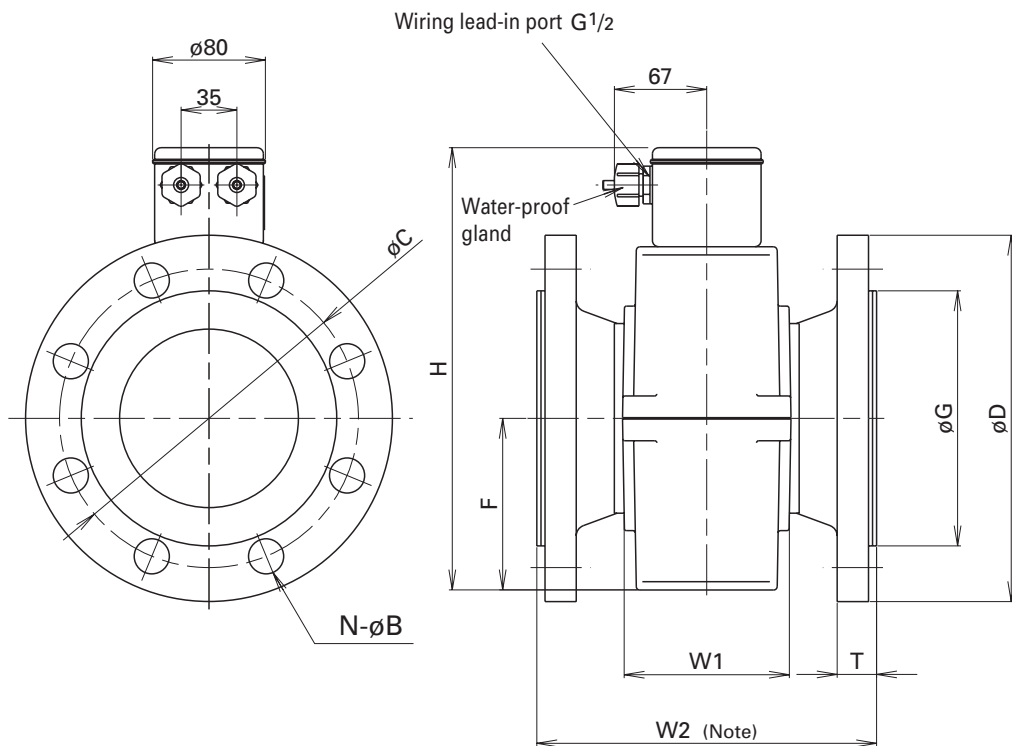

Meter size	150A	200A	250A	300A	
W1	170	195	250	250	
W2	300 ⁰ / ₋₃	350 ⁰ / ₋₃	450 ⁰ / ₋₅	500 ⁰ / ₋₅	
JIS 10K flange	ϕD	280	330	400	445
	ϕC	240	290	355	400
	N- ϕB	8-23	12-23	12-25	16-25
	T	25	28	30	31
	ϕG	212	268	320	370
	H	368	430	486	572
	F	148	179	207	250
Mass (kg)	29	53	79	81	

(Note) W2 are dimensions after positioning to piping.
 The lining flare sections are not glued before positioning to piping
 (There are about 30mm protruding of each side.)

< Stainless tag >
 Option

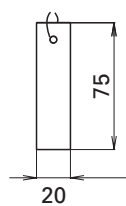

EXTERNAL CONNECTION DIAGRAM

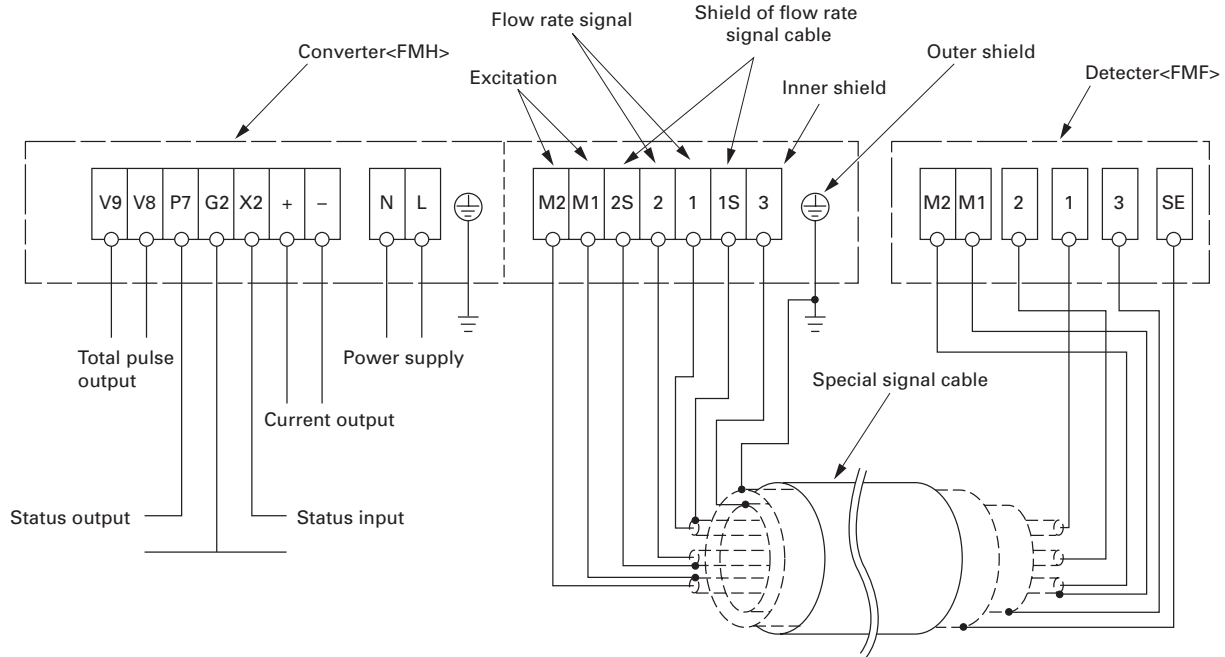

FLOW RATE - FLOW VELOCITY CONVERSION DIAGRAM

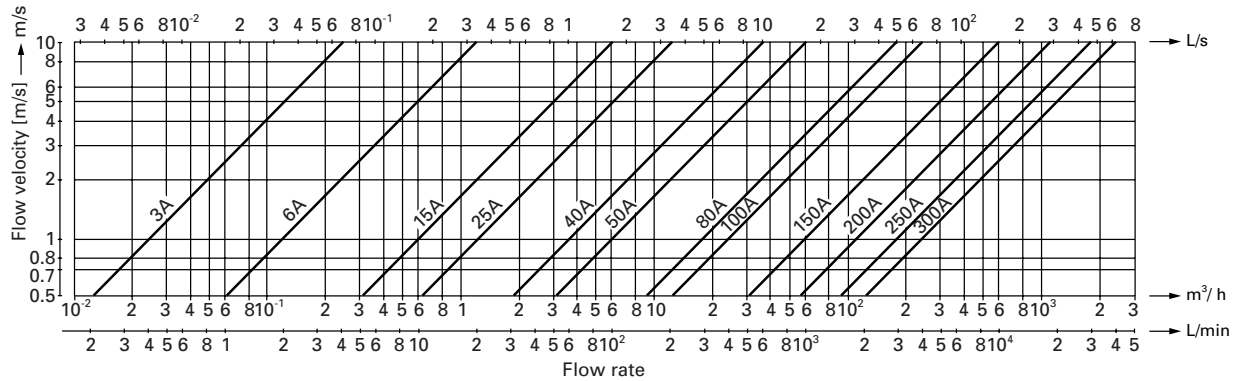

SCOPE OF DELIVERY

- Detector (mounting bolt and packing should be prepared separately).
- Converter ×1 (with metal fixtures for pipe-mount or wall-mount)
- Special signal cable ×1 (length; by specifying)
- Magnetic stick

SPARE PARTS

- Guide rings (note) / for wafer type.
- Note) Not supplied for 80A and 100A JIS 10K.

ITEMS SPECIFIED AT ORDERING

1. Type, specification code.
2. Flow measurement range and measurement fluid.
3. When ordering "with stainless tag plate," specify Tag No. (up to 16 alphanumeric characters) as needed.
4. When ordering "with parameter setting," complete and send the attached parameter designation table.

HOW TO CONNECT CABLE

1. Press the terminal spring by inserting a minus driver (small) through the opening at top.
2. Insert terminated cable into the cable lead-in port as shown below.
3. When the driver is removed, the cable is fixed (connected) by the spring force in the terminal.

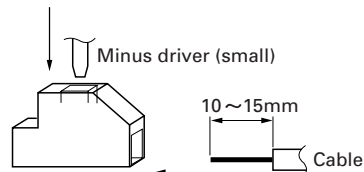

Note) Cable should be securely fixed with the supplied water-proof gland.

If you want the instrument with certain parameters factory set as you desire, specify them in the following parameter designation tables 1 and 2.

Company : _____ Sector : _____
 Name : _____ Telephone No. : _____
 Measured fluid : _____

<Parameter designation table 1> Put check marks into which precede items to modify for.

Setting item	Standard set value (Note 1)	Range	Item to select	Item selection or value designation	Example
Damping	5.0s	1.0 to 99.0s		____ . ____ [s]	020.0s
LCD 1st line indication	Real scale indication Unit: m ³ /h	<1st line, 2nd line> ① Real scale indication Volume unit: mL, L, m ³ Mass unit: g, kg Time unit: /s, /min, /h ② Arbitrary real scale unit • Unit factor: 0.00001 to 9999999 • Unit name: Arbitrary value of 4 characters ③ Percent indication (%) ④ Total real scale indication Volume unit: mL, L, m ³ Mass unit: g, kg ⑤ Arbitrary total real scale unit • Unit factor: 0.00001 to 9999999 • Unit name: Arbitrary value of 4 characters ⑥ TAG No. indication ⑦ Bar graph indication (Percent indication can also be indicated simultaneously in 1% step) ⑧ Non-display	<Designation of 1st line indication> Select an item from the following. <input type="checkbox"/> Real scale indication	According to selection of left item, designate necessary item and value. Volume unit: <input type="checkbox"/> mL, <input type="checkbox"/> L, <input type="checkbox"/> m ³ Mass unit: <input type="checkbox"/> g, <input type="checkbox"/> kg Time unit: <input type="checkbox"/> /s, <input type="checkbox"/> /min, <input type="checkbox"/> /h	
			<input type="checkbox"/> Arbitrary real scale indication	Unit factor: 0.00001 to 9999999 *Value converted the units into L _____ Unit name: _____	1000000
			<input type="checkbox"/> Percent indication	None.	t/h
			<input type="checkbox"/> Total real scale indication	Volume unit: <input type="checkbox"/> mL, <input type="checkbox"/> L, <input type="checkbox"/> m ³ Mass unit: <input type="checkbox"/> g, <input type="checkbox"/> kg	
			<input type="checkbox"/> Arbitrary total real scale indication	Unit factor: 0.00001 to 9999999 *Value converted the units into L _____ Unit name: _____	1000000
			<input type="checkbox"/> TAG No. indication	None	
			<input type="checkbox"/> Bar graph indication	None	
			<input type="checkbox"/> Non-display	None	
LCD 2nd line indication	Total real scale indication Unit: m ³	⑧ Non-display	<Designation of 2nd line indication> Select an item from the following. <input type="checkbox"/> Real scale indication	According to selection of left item, designate necessary item and value. Volume unit: <input type="checkbox"/> mL, <input type="checkbox"/> L, <input type="checkbox"/> m ³ Mass unit: <input type="checkbox"/> g, <input type="checkbox"/> kg Time unit: <input type="checkbox"/> /s, <input type="checkbox"/> /min, <input type="checkbox"/> /h	
			<input type="checkbox"/> Arbitrary real scale indication	Unit factor: 0.00001 to 9999999 *Value converted the units into L _____ Unit name: _____	1000000
			<input type="checkbox"/> Percent indication	None.	t/h
			<input type="checkbox"/> Total real scale indication	Volume unit: <input type="checkbox"/> mL, <input type="checkbox"/> L, <input type="checkbox"/> m ³ Mass unit: <input type="checkbox"/> g, <input type="checkbox"/> kg	
			<input type="checkbox"/> Arbitrary total real scale indication	Unit factor: 0.00001 to 9999999 *Value converted the units into L _____ Unit name: _____	1000000
			<input type="checkbox"/> TAG No. indication	None	
			<input type="checkbox"/> Bar graph indication	None	
			<input type="checkbox"/> Non-display	None	
Range	By table-1 (Note 5)	0.5 to 10 m/s converted to flow velocity.	Volume unit: <input type="checkbox"/> mL, <input type="checkbox"/> L, <input type="checkbox"/> m ³ Time unit: <input type="checkbox"/> /s, <input type="checkbox"/> /min, <input type="checkbox"/> /h, <input type="checkbox"/> /d	Must be designated in 4 significant digits. Value: _____	100.0
Instantaneous output low-cut point	0.0%	0.0% to 10.0%	None.	____ . ____ %	3.5%
Total direction	FORWARD /REVERSE (Note4)	FORWARD FORWARD/REVERSE	<input type="checkbox"/> FORWARD <input type="checkbox"/> FORWARD/REVERSE	None.	
Total constant (Note 2) (Total value per pulse)	1m ³	Value: 0.001 to 1000 Unit : mL, L, m ³	Volume unit: <input type="checkbox"/> mL, <input type="checkbox"/> L, <input type="checkbox"/> m ³	Value: _____	
Total pulse width (Note 3)	30ms	0.1 to 2000ms	None.	____ . ____ [ms]	50.0[ms]
Filter	off	on off	<input type="checkbox"/> on <input type="checkbox"/> off	None.	

<Parameter designation table 2>

Setting item	Standard set value (Note 1)	Range	Item to select	Item selection or value designation	Example
Empty detection function	off	on off	<input type="checkbox"/> on <input type="checkbox"/> off	Alarm output value <input type="checkbox"/> 3.6mA <input type="checkbox"/> 4mA <input type="checkbox"/> 24.8mA	
Upper/Lower limit alarm	Upper limit value : 130% Lower limit value : 0%	Upper limit value: 0 to 130% Lower limit value: 0 to 130%	<input type="checkbox"/> Upper limit alarm <input type="checkbox"/> Lower limit alarm <input type="checkbox"/> Upper/Lower limit alarm	Alarm output value <input type="checkbox"/> 3.6mA <input type="checkbox"/> 4mA <input type="checkbox"/> 24.8mA Upper limit value: ____ . ____ % Lower limit value: ____ . ____ %	Upper limit value: 120.0% Lower limit value: 0.0%
Specific gravity	1.000g/cm ³	0.01~5g/cm ³	None	_____ g/cm ³	0.95g/cm ³
TAG-NO	Blank unless designated	Up to 16 alphanumeric	None	_____	F-100
Flow direction	STANDARD	STANDARD OPPOSITE	<input type="checkbox"/> STANDARD <input type="checkbox"/> OPPOSITE	None	

(Note 1) Standard set value refers to parameter set value as factory set in case parameter setting is not designated.

(Note 2) Designate so that the number of total pulse outputs will be below 5kHz at the maximum flow rate (to meet the following equation).

$$\text{Range [m}^3/\text{h]} / (\text{total constant [m}^3] \times 3600) \leq 5000$$

(Note 3) Designate the total pulse width so as to hold: (Total constant [m³] × 3600/range [m³/h] ≥ total pulse width [ms]/500

(Note 4) When selecting FORWARD/REVERSE from the total direction, total pulse is only outputted in the FORWARD direction.

(Note 5) Factory-set range before shipment (unless specified).

Table-1

Meter size	Range [m ³ /h]	Meter size	Range [m ³ /h]	Meter size	Range [m ³ /h]
3A	0.05	40A	14.0	150A	120.0
6A	0.2	50A	14.0	200A	220.0
15A	1.2	80A	35.0	250A	350.0
25A	3.5	100A	55.0	300A	350.0

(Material selection table of electrode/earth ring)

Material of electrode/earth ring	Measurable liquid	Unmeasurable liquid
SUS316	Water and waste water, weak acid, weak alkali Example: 25% acetic acid or less, hydroiodic acid, butyric acid, aqueous ammonia or alike	Inorganic acid, organic acid, chloride or alike
Hastelloy C-4 or equivalent	Suitable for intermediate oxidation and reduction and can be used for various fields. Example: Sea water, formic acid, acetic acid, aqueous ammonia, normal-temperature nitric acid and sulfuric acid or alike	Chloride, high-temperature strong acids (nitric acid, hydrochloric acid, sulfuric acid), ferric chloride or alike
Titanium	Resistant to sea water, most oxidative acids, chloride, sulfide and alkali. Example: Sea water, saline water, aqueous ammonia, chlorine water, polyelectrolyte, acetic acid, ferric chloride or alike	Reductive acids such as hydrochloric acid, sulfuric acid, phosphoric acid, oxalic acid
Tantalum	Resistant to most chemicals. (particularly, strong acids) Example: Hydrochloric acid, sulfuric acid, nitric acid, aqua regia, ferric chloride, hypochlorous acid, sodium hypochlorite, PAC (Polyaluminum chloride) or alike	Sodium hydroxide, potassium hydroxide, hydrofluoric acid, fuming sulfuric acid or alike
Platinum-iridium (Pt-Ir)	Resistant to almost chemicals.	Aqua regia

(Note): The electrode/earth ring for E-series electromagnetic flowmeter use Hastelloy C-4 or equivalent.

If other material except Hastelloy C-4 is required, select a model that uses other material from the separate type electromagnetic flowmeter (FMB/C series) of Fuji Electric.

⚠ Caution on Safety

*Before using this product, be sure to read its instruction manual in advance.

Fuji Electric Systems Co., Ltd.

Head Office

6-17, Sanbancho, Chiyoda-ku, Tokyo 102-0075, Japan
http://www.fesys.co.jp/eng

Sales Div.

International Sales Dept.

No.1, Fuji-machi, Hino-city, Tokyo, 191-8502 Japan
Phone: 81-42-585-6201, 6202 Fax: 81-42-585-6187
http://www.fic-net.jp/eng