

# FC SERIES HIGH DIFFERENTIAL PRESSURE TRANSMITTER

DATA SHEET

FFF

FC SERIES capacitance type differential pressure transmitters provide precise measurement of flow rate, differential pressure, pressure and liquid level of various liquids, gases and steam.

Process high and low pressures act on the flat diaphragm through metal seal diaphragms and change capacitance by deflection of the flat diaphragm or a moving electrode. This change is measured and converted to a signal current in the electronics circuit for transmission to receiving instruments.

Explosionproof, field indicator, corrosion resistant materials, built-in arrester and other specifications are fully filled up.

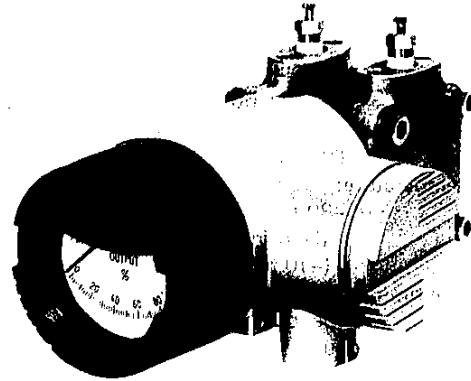

## FEATURES

- High accuracy**  
The simple measuring principle to detect the capacitance change by a very small deflection of the flat diaphragm and the unique Floating Cell system assures high accuracy of 0.25%. The influence of static pressure, overload and temperature is smaller than any other transmitters on the market.
- High reliability and long-term stability**  
All welded, simple mechanism with few parts causes little failure and drift.
- Excellent environmental adaptability**  
Minimal influence of vibration, weather and radio frequency interference enables this transmitter to locate in almost all circumstances.
- Easy maintenance and handling**  
Compact and lightweight design ensures speedy installation. Zero, span and damping are easily and independently adjusted on the front panel. The detecting unit and the electronics unit are interchangeable and easily replaceable because of the three block structure.
- Full range specifications**  
To meet any process requirements, a wide choice of explosionproof, large indicator, arrester, corrosion resistant materials, various treatments, integral orifice, equalizing valve etc. are available.
- Wide rangeability**  
Each transmitter is available with 10 to 1 turndown for application flexibility. FC SERIES transmitters are offered in six ranges; 0 to 10 mmH<sub>2</sub>O to 0 to 30 kg/cm<sub>2</sub> with the same structure and size.

Working pressure:

- 1 to 63, 100, 420 kg/cm<sup>2</sup>

Note) Working pressure is decided according to materials. Refer to the following table.

Material:

Detecting unit;

Material code	Process cover	Measuring element		Pressure rating (kg/cm <sup>2</sup> )
		Seal diaphragm	Other wetted part	
W	SUS316	SUS316L	SUS316	100
E	Carbon steel	SUS316L	SUS316	420
H	SUS316	Hastelloy C	Hastelloy C	100
M	SUS316	Monel	Monel	100
T	SUS316	Tantalum	Tantalum	100
B	Hastelloy C lining	Hastelloy C	Hastelloy C	63
L	Monel lining	Monel	Monel	63
R	Hastelloy C lining	Tantalum	Tantalum	63

Note) For details of measuring range, working pressure and material, refer to "Code Symbols".

O-Ring; Viton  
(Teflon for material code B, L, R)  
Fill; Silicone or daifloil (fluorinated fluid for oxygen measurement)  
Electronics casing;  
Aluminium alloy  
Epoxy-polyurethane double coating, silver  
Field indicator cover, black N3

Zero shift: Adjustable from -32% to +100% of maximum span.  
(The sum of zero shift and calibrated span should not exceed the upper range limit.)

## SPECIFICATIONS

Measuring range: FFF□5; 0 to 3,200...32,000 mmH<sub>2</sub>O  
FFF□6; 0 to 30,000...300,000 mmH<sub>2</sub>O

- Output signal: DC 4 to 20mA or DC 10 to 50mA
- Power supply and allowable load resistance:
  - DC 4 to 20mA output
  - DC 12 to 45V  
(Less than DC 27V: with arrester)
  - 0 to 600Ω (at DC 24V power supply)
  - DC 10 to 50mA output
  - DC 25 to 70V
  - 0 to 450Ω (at DC 48V power supply)
- Wiring system: 2-wire system
- Ambient temperature:
  - 30 to 80°C
  - (-30 to 60°C: with arrester)
  - (-10 to 60°C: oxygen measurement)
- Weather resistance: DIN 40040 HQC
- Fluid temperature:
  - 30 to 100°C
  - (Non-freezing condition)
  - (-10 to 60°C: oxygen measurement)
- Response time: Faster than 0.1 sec. (time constant of the detecting unit at room temperature)
- Adjustable damping:
  - Four steps selectable; no damping, and time constants of 0.2, 1 and 3 sec.
- Waterproof: IEC IP65 or NEMA4
- Explosionproof:

	Certifying authority	Area classification	Temperature classification
Flameproof (Explosionproof)	FM	Class I, Division 1 Group B, C, D	T6
	CSA	Class I, Division 1 Group C, D	T6
Intrinsically safe	FM	Class I, Division 1 Group A, B, C, D	T6
	CSA	Class I, Division 1 Group A, B, C, D	T6
	SAA	Exia II C	T6
	PTB	Exib II C	T5, T6

FM : Factory Mutual Research (USA)  
 CSA : Canadian Standards Association  
 SAA : Standards Association of Australia  
 PTB : Physikalisch-Technische Bundesanstalt

- Dimensions (HxWxD) and weight:
  - FFF3; 143x164x237 (267)\*mm,  
Approx. 6.5 kg
  - FFF4; 169x183x246 (276)\*mm,  
Approx. 12 kg
  - FFF6; 109x204x235 (265)\*mm,  
Approx. 8 kg
- \*: with field indicator

- Mounting method:
  - On a horizontal or vertical 2" pipe by using a U-bolt
- Process connection:
  - 1/4-18NPT internal thread  
(1/2-14NPT with oval flange)
- Conduit connection:
  - 1/2-14NPT internal thread

## OPTIONAL SPECIFICATIONS

- Field indicator: Built in the electronics casing, class 1.5  
0 to 100% linear, square root
- Arrester: Built in the electronics casing  
(DC 4 to 20mA output only)
- Oxygen measurement:
  - Daifloil (fluorinated fluid) filled and special cleaning (not available for material code "E")
- Acid and alkali-proof treatment:
  - Detecting unit bolts: 17-4 PH SS
  - U-bolt, nuts and washers: SUS 304
- Oval falange: Available for process connection flange.  
For details, refer to the oval flange data sheet EDS 6-10.

## CHARACTERISTICS

- (indicated by % of span with stainless steel diaphragm and silicone fill)
- Accuracy: Better than ±0.25%  
(under reference operating conditions, includes linearity, hysteresis and repeatability)
- Repeatability: Better than ±0.1%
- Sensitivity: Better than 0.05%
- Temperature effect: \*1), \*2)  
At maximum span and between -30 to 80°C;  
Total effect (zero and span) ±1%/55°C
- Static pressure effect: \*1), \*2)  
At maximum span:  
Zero shift 0.2%/100 kg/cm<sup>2</sup>
- Allowable differential overpressure: Up to the max. working pressure
- Effect of differential overpressure:
  - At maximum span:  
Zero shift 0.3%/±100 kg/cm<sup>2</sup>  
0.8%/±420 kg/cm<sup>2</sup>
- Power fluctuation:
  - Zero shift 0.005%/V
- Effect of position:
  - Zero shift 10 mmH<sub>2</sub>O/10°\*2)

Note \*1) This is doubled for corrosion resistance materials (Code: H, M, T, B, L and R)

\*2) This is doubled for oxygen measurement.

# CODE SYMBOLS

Description																																													
3	Pressure rating (kg/cm <sup>2</sup> )																																												
4	100																																												
4	420																																												
6	63																																												
5	Measuring range (mmH <sub>2</sub> O)																																												
5	0 to 3,200 ... 32,000																																												
6	0 to 30,000...300,000																																												
Materials of detecting unit																																													
<table border="1"> <thead> <tr> <th rowspan="2">Process cover</th> <th colspan="2">Measuring element</th> </tr> <tr> <th>Seal diaphragm</th> <th>Other wetted part</th> </tr> </thead> <tbody> <tr> <td>W JIS SUS316</td> <td>SUS316L</td> <td>SUS316</td> </tr> <tr> <td>E Carbon steel</td> <td>SUS316L</td> <td>SUS316</td> </tr> <tr> <td>H SUS316</td> <td>Hastelloy C</td> <td>Hastelloy C</td> </tr> <tr> <td>M SUS316</td> <td>Monel</td> <td>Monel</td> </tr> <tr> <td>T SUS316</td> <td>Tantalum</td> <td>Tantalum</td> </tr> <tr> <td>B Hastelloy C lining</td> <td>Hastelloy C</td> <td>Hastelloy C</td> </tr> <tr> <td>L Monel lining</td> <td>Monel</td> <td>Monel</td> </tr> <tr> <td>R Hastelloy C lining</td> <td>Tantalum</td> <td>Tantalum</td> </tr> </tbody> </table>		Process cover	Measuring element		Seal diaphragm	Other wetted part	W JIS SUS316	SUS316L	SUS316	E Carbon steel	SUS316L	SUS316	H SUS316	Hastelloy C	Hastelloy C	M SUS316	Monel	Monel	T SUS316	Tantalum	Tantalum	B Hastelloy C lining	Hastelloy C	Hastelloy C	L Monel lining	Monel	Monel	R Hastelloy C lining	Tantalum	Tantalum															
Process cover	Measuring element																																												
	Seal diaphragm	Other wetted part																																											
W JIS SUS316	SUS316L	SUS316																																											
E Carbon steel	SUS316L	SUS316																																											
H SUS316	Hastelloy C	Hastelloy C																																											
M SUS316	Monel	Monel																																											
T SUS316	Tantalum	Tantalum																																											
B Hastelloy C lining	Hastelloy C	Hastelloy C																																											
L Monel lining	Monel	Monel																																											
R Hastelloy C lining	Tantalum	Tantalum																																											
Electronics unit, field indicator and arrester																																													
<table border="1"> <thead> <tr> <th colspan="2">Field indicator</th> <th rowspan="2">Arrester</th> <th rowspan="2">Output signal</th> <th rowspan="2">Note</th> </tr> <tr> <th>Yes/No</th> <th>Scale</th> </tr> </thead> <tbody> <tr> <td>A -</td> <td>-</td> <td>-</td> <td>-</td> <td rowspan="8">Not available for intrinsic safety</td> </tr> <tr> <td>B ○</td> <td>0 to 100% linear</td> <td>-</td> <td>-</td> </tr> <tr> <td>D ○</td> <td>0 to 100% square root</td> <td>-</td> <td>DC</td> </tr> <tr> <td>G -</td> <td>-</td> <td>○</td> <td>4 to 20mA</td> </tr> <tr> <td>H ○</td> <td>0 to 100% linear</td> <td>○</td> <td>-</td> </tr> <tr> <td>K ○</td> <td>0 to 100% square root</td> <td>○</td> <td>-</td> </tr> <tr> <td>P -</td> <td>-</td> <td>-</td> <td>-</td> </tr> <tr> <td>Q ○</td> <td>0 to 100% linear</td> <td>-</td> <td>DC</td> </tr> <tr> <td>R ○</td> <td>0 to 100% square root</td> <td>-</td> <td>10 to 50mA</td> </tr> </tbody> </table>		Field indicator		Arrester	Output signal	Note	Yes/No	Scale	A -	-	-	-	Not available for intrinsic safety	B ○	0 to 100% linear	-	-	D ○	0 to 100% square root	-	DC	G -	-	○	4 to 20mA	H ○	0 to 100% linear	○	-	K ○	0 to 100% square root	○	-	P -	-	-	-	Q ○	0 to 100% linear	-	DC	R ○	0 to 100% square root	-	10 to 50mA
Field indicator		Arrester	Output signal				Note																																						
Yes/No	Scale																																												
A -	-	-	-	Not available for intrinsic safety																																									
B ○	0 to 100% linear	-	-																																										
D ○	0 to 100% square root	-	DC																																										
G -	-	○	4 to 20mA																																										
H ○	0 to 100% linear	○	-																																										
K ○	0 to 100% square root	○	-																																										
P -	-	-	-																																										
Q ○	0 to 100% linear	-	DC																																										
R ○	0 to 100% square root	-	10 to 50mA																																										
Hazardous location																																													
9	Non-explosionproof																																												
5	FM approved explosionproof																																												
6	CSA " " "																																												
A	FM approved intrinsically safe with STAHL barrier																																												
B	FM " " " " TAYLOR barrier																																												
C	FM " " " " WESTING HOUSE barrier																																												
D	FM " " " " M.T.L barrier																																												
F	FM " " " " FOXBORO barrier																																												
G	FM " " " " HONEY WELL barrier																																												
K	SAA " " " " M.T.L barrier																																												
L	PTB " " " "																																												
P	CSA " " " " STAHL barrier																																												
Q	CSA " " " " TAYLOR barrier																																												
S	CSA " " " " M.T.L barrier																																												
U	CSA " " " " FOXBORO barrier																																												
V	CSA " " " " HONEY WELL barrier																																												
Input/output																																													
0	Normal operation																																												
1	Reverse operation																																												
Special specifications																																													
0	Standard																																												
2	Low temperature service (-40 to +60°)																																												
Treatment																																													
Y	Standard																																												
A	Oxygen measurement (O <sub>2</sub> no oil treatment)																																												
B	Acid and alkali-proof treatment																																												
A + B	A + B																																												

## Barriers and Gas groups

Codes	Certified by	Barrier	Installation drawing	Applicable gas groups
A	FM	STAHL, 8901, 8903	TC 408292	A, B, C, D
B	FM	Taylor, 1130, 1135	TC 408293	C, D
C	FM	Westinghouse, 75S802	TC 408294	A, B, C, D
D	FM	MTL, 128, 188, 322	TC 408660	A, B, C, D
F	FM	Foxboro,	TC 409102	B, C, D
G	FM	Honeywell, 38545	TC 408625	A, B, C, D
K	SAA	MTL, 128, 188, 322	TD 407370	II C
L	PTB	Ik ≤ 100mA, U ≤ 30V		II C
P	CSA	STAHL, 8901, 8903	TC 408628	A, B, C, D
Q	CSA	Taylor, 1130, 1135	TC 408629	C, D
S	CSA	MTL, 128, 188, 322	TC 408661	A, B, C, D
U	CSA	Foxboro,	TC 409101	B, C, D
V	CSA	Honeywell, 38545	TC 408630	A, B, C, D

## Pressure rating, Measuring range and Material

Type	Pressure rating (kg/cm <sup>2</sup> )	Measuring range (mmH <sub>2</sub> O)	Material							
			W	E	H	M	T	B	L	R
FFF35	100	0 to 3200... 32000	○	○	○	○				
FFF36	100	0 to 30000...300000	○							
FFF45	420	0 to 3200... 32000	○							
FFF46	420	0 to 30000...300000	○							
FFF65	63	0 to 3200... 32000							○	○

OUTLINE DIAGRAM (Unit:mm)

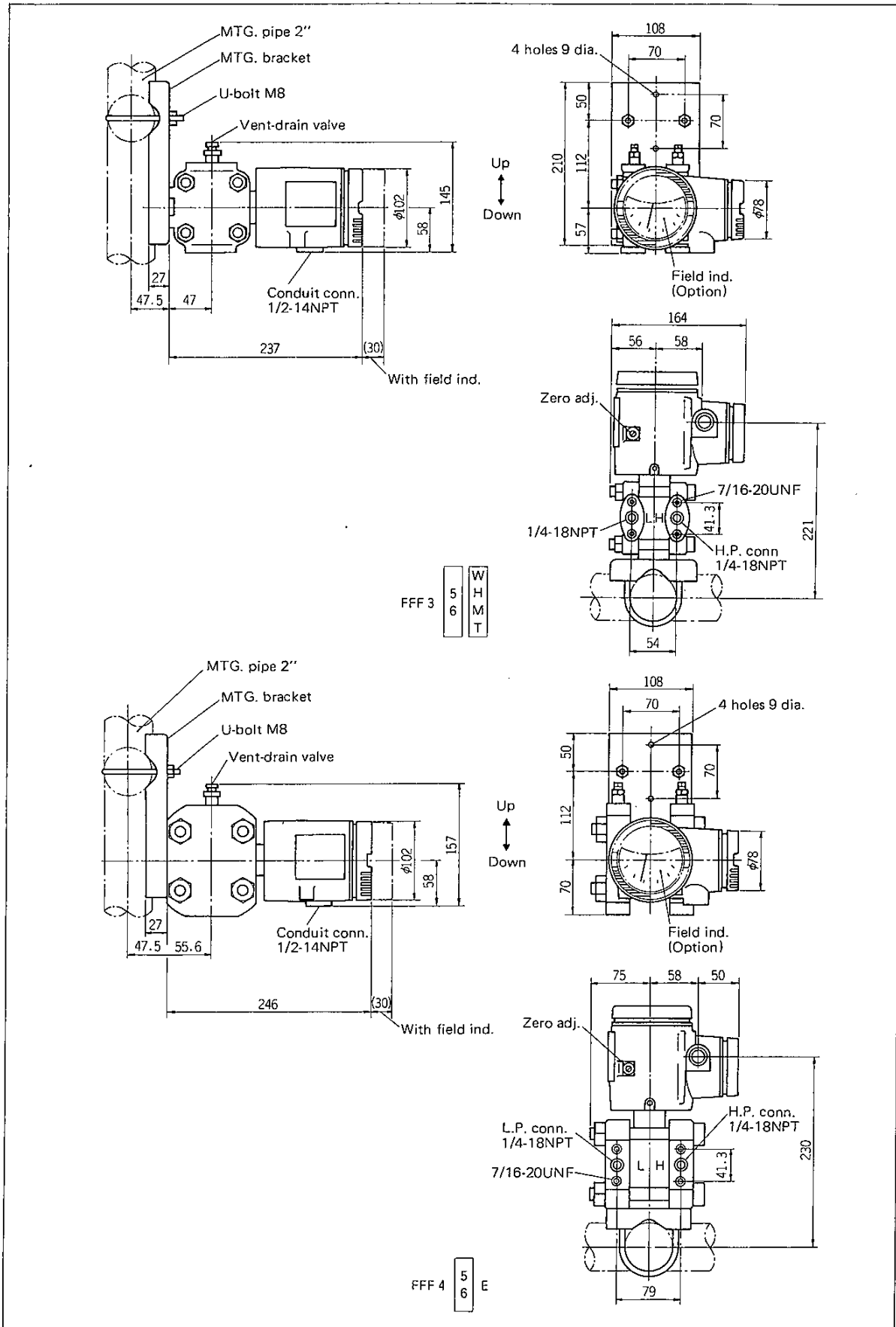

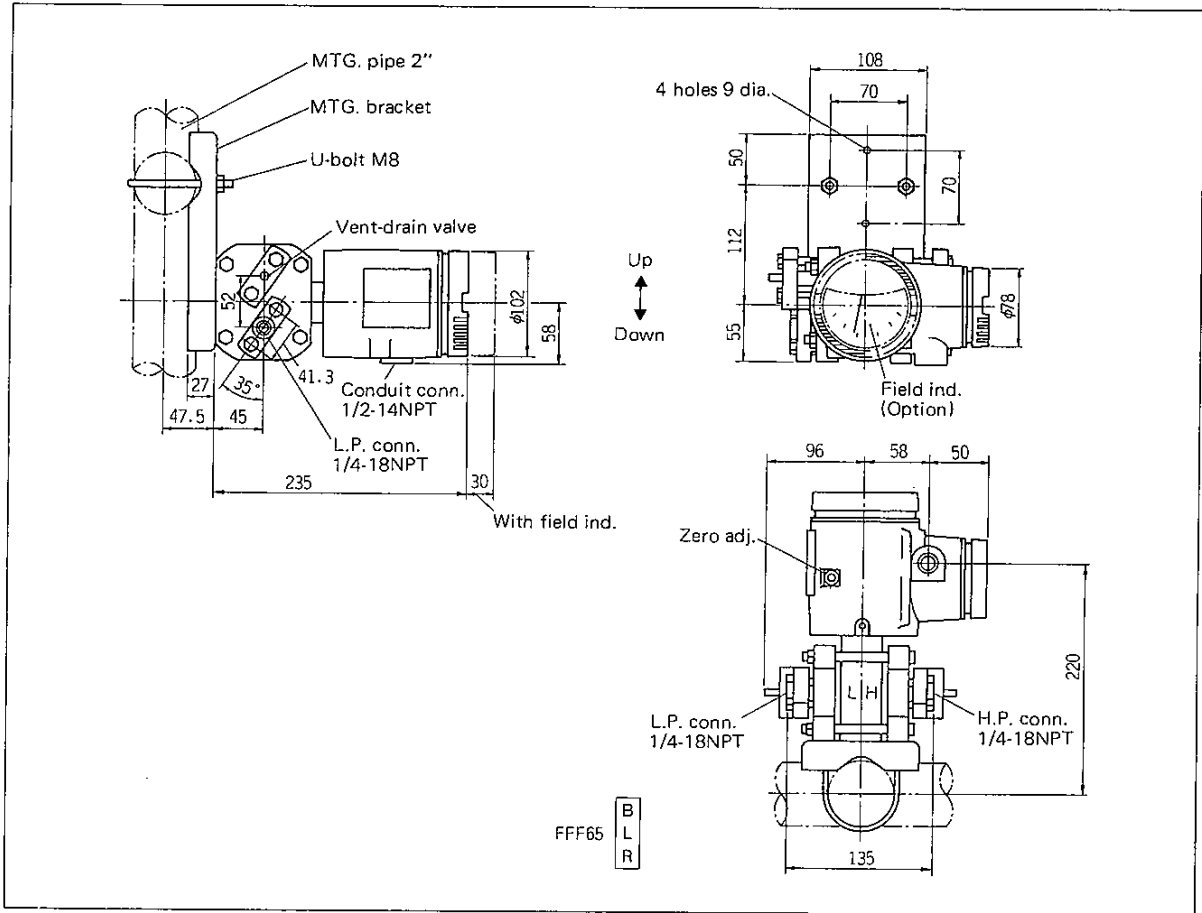

## STRUCTURAL PRINCIPLE

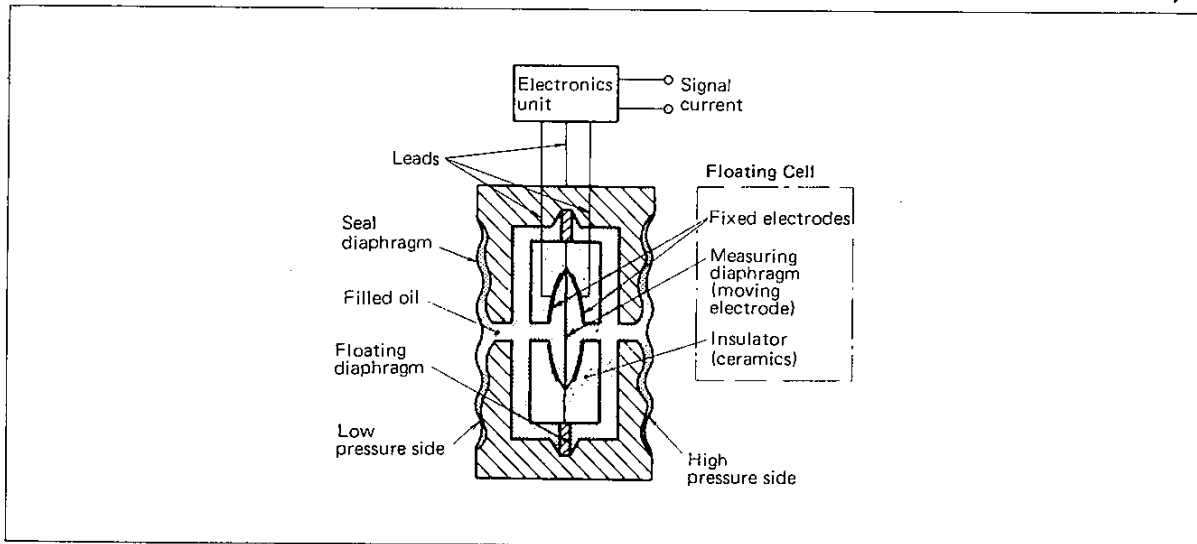

## FUNDAMENTAL BLOCK DIAGRAM

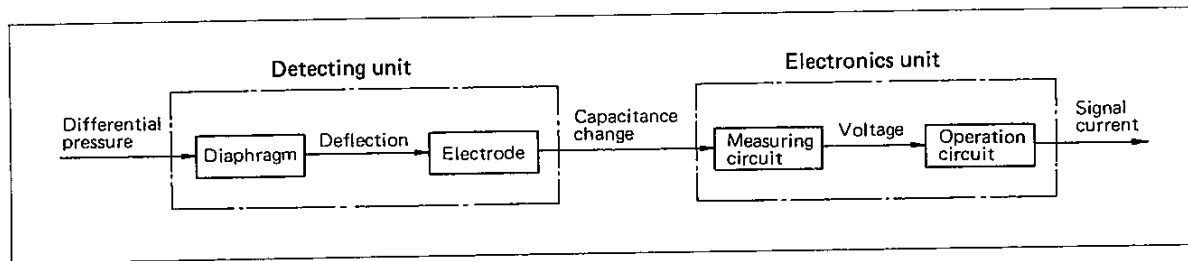

## CONNECTION DIAGRAM

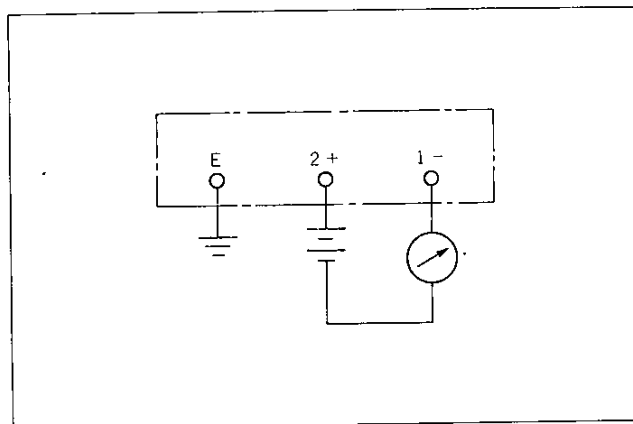

## RELATED DEVICES

- Equalizing valve
- Oval flange
- Integral orifice
- Opener
- Distributor

## ORDERING INFORMATION

1. Measuring object or application
2. Product name
3. Code symbols
4. Operating pressure and measuring range
5. Material of detecting unit
6. Explosionproof or special specifications
7. Other requirements