

CEL

NEC's HIGH CMR, 10Mbps OPEN COLLECTOR OUTPUT TYPE 5-PIN SOP OPTOCOUPLER

PS9117

DESCRIPTION

NEC's PS9117 is an optically coupled high-speed, active low type isolator containing a GaAlAs LED on the input side and a photodiode and a signal processing circuit on the output side on one chip.

The PS9117 is designed specifically for high common mode transient immunity (CMR) and low pulse width distortion. The PS9117 is suitable for high density application.

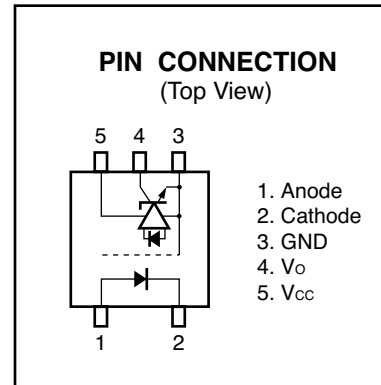

FEATURES

- **PULSE WIDTH DISTORTION:**
tPHL - tPLHL = 35 ns MAX.
- **HIGH COMMON MODE TRANSIENT IMMUNITY:**
CMH, CML = ±15 kV/μs MIN.
- **SMALL PACKAGE:**
5-Pin SOP
- **HIGH SPEED:**
10 Mbps
- **HIGH ISOLATION VOLTAGE:**
BV = 2 500 Vr.m.s.
- **OPEN COLLECTOR OUTPUT**
- **ORDERING NUMBER OF TAPING PRODUCT:**
PS9117-F3, F4: 2 500 pcs/reel
- **Pb-Free Product**
- **SAFETY STANDARDS:**
UL approved: File No. E72422
DIN EN60747-5-2 (VDE0884 Part2) approved No. 40008902 (option)

TRUTH TABLE

LED	OUTPUT
ON	L
OFF	H

APPLICATION

- Measurement Equipment
- PDP
- FA Network

PACKAGE DIMENSIONS (UNIT: mm)

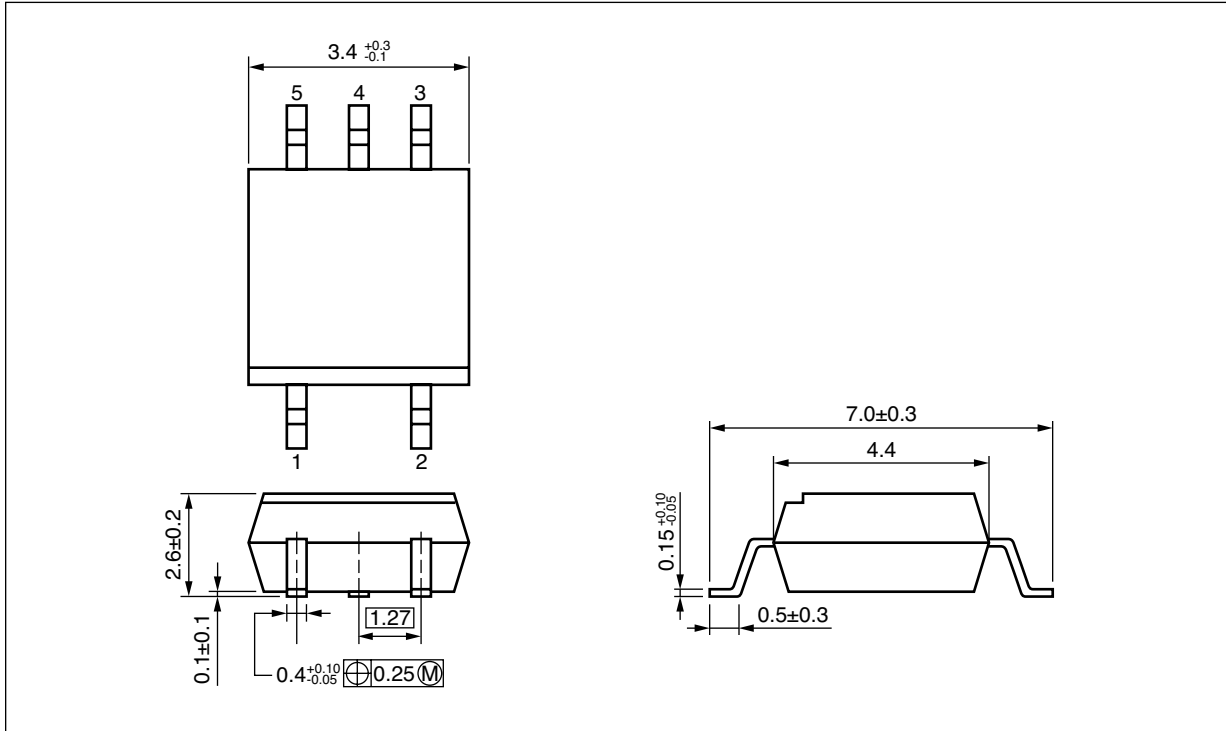

MARKING EXAMPLE

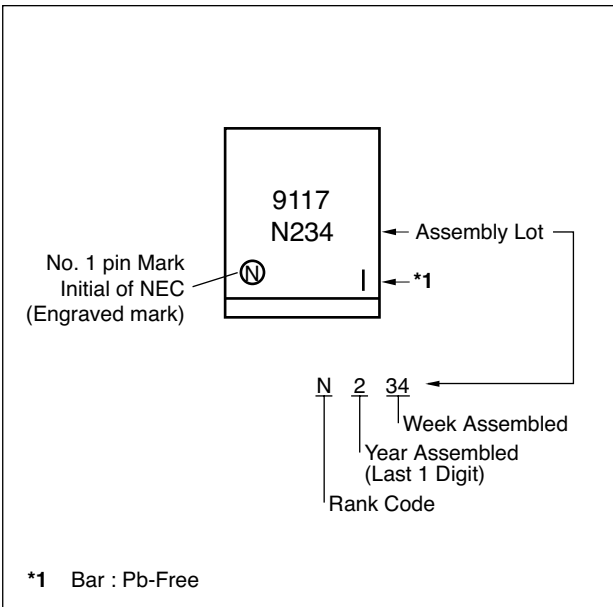

ORDERING INFORMATION

PART NUMBER	ORDER NUMBER	SOLDER PLATING SPECIFICATION	PACKING STYLE	SAFETY STANDARDS APPROVAL	APPLICATION PART NUMBER ^{*1}
PS9117	PS9117-A	Pb-Free ^{*2}	Magazine case 100 pcs	UL approved	PS9117
PS9117-F3	PS9117-F3-A		Embossed Tape 2 500 pcs/reel		
PS9117-F4	PS9117-F4-A				
PS9117-V	PS9117-V-A		Magazine case 100 pcs	DIN EN60747-5-2 (VDE0884 Part2) Approved (Option)	
PS9117-V-F3	PS9117-V-F3-A		Embossed Tape 2 500 pcs/reel		
PS9117-V-F4	PS9117-V-F4-A				

*1 For the application of the Safety Standard, following part number should be used.

*2 With regards to terminal solder (the solder contains lead) plated products (conventionally plated), contact your nearby sales office.

ABSOLUTE MAXIMUM RATINGS (T_A = 25°C, unless otherwise Specified)

	PARAMETER	SYMBOL	RATINGS	UNIT
Diode	Forward Current ^{*1}	I _F	30	mA
	Reverse Voltage	V _R	5	V
Detector	Supply Voltage	V _{CC}	7	V
	Output Voltage	V _O	7	V
	Output Current	I _O	25	mA
	Power Dissipation ^{*2}	P _C	40	mW
Isolation Voltage ^{*3}		BV	2 500	Vr.m.s.
Operating Ambient Temperature		T _A	-40 to +85	°C
Storage Temperature		T _{stg}	-55 to +125	°C

*1 Reduced to 0.3 mA/°C at T_A = 25°C or more.

*2 Applies to output pin V_O (collector pin). Reduced to 1.5 mW/°C at T_A = 65°C or more.

*3 AC voltage for 1 minute at T_A = 25°C, RH = 60% between input and output.

RECOMMENDED OPERATING CONDITIONS

PARAMETER	SYMBOL	MIN.	TYP.	MAX.	UNIT
Low Level Input Voltage	V _{FL}	0		0.8	V
High Level Input Current	I _{FH}	6.3	10	12.5	mA
Supply Voltage	V _{CC}	4.5	5.0	5.5	V
TTL (R _L = 1 kΩ, loads)	N			5	
Pull-up Resistor	R _L	330		4 k	Ω

ELECTRICAL CHARACTERISTICS (T_A = -40 to 85°C, unless otherwise specified)

PARAMETER		SYMBOL	CONDITIONS	MIN.	TYP. ¹	MAX.	UNIT	
Diode	Forward Voltage	V _F	I _F = 10 mA, T _A = 25°C	1.4	1.65	1.8	V	
	Reverse Current	I _R	V _R = 3 V, T _A = 25°C			10	μA	
	Terminal Capacitance	C _t	V = 0 V, f = 1 MHz, T _A = 25°C		30		pF	
Detector	High Level Output Current	I _{OH}	V _{CC} = V _O = 5.5 V, V _F = 0.8 V		1	100	μA	
	Low Level Output Voltage ²	V _{OL}	V _{CC} = 5.5 V, I _F = 5 mA, I _{OL} = 13 mA		0.2	0.6	V	
	High Level Supply Current	I _{CCH}	V _{CC} = 5.5 V, I _F = 0 mA		5	8	mA	
	Low Level Supply Current	I _{CCL}	V _{CC} = 5.5 V, I _F = 10 mA		9	11		
Coupled	Threshold Input Current (H → L)	I _{FHL}	V _{CC} = 5 V, V _O = 0.8 V, R _L = 350 Ω		2	5		
	Isolation Resistance	R _{I-O}	V _{I-O} = 1 kV _{DC} , R _H = 40 to 60%, T _A = 25°C	10 ¹¹			Ω	
	Isolation Capacitance	C _{I-O}	V = 0 V, f = 1 MHz, T _A = 25°C		0.6		pF	
	Propagation Delay Time (H → L) ³	t _{PHL}	V _{CC} = 5 V, R _L = 350 Ω, I _F = 7.5 mA	T _A = 25°C	35	75	ns	
						100		
	Propagation Delay Time (L → H) ³	t _{PLH}	V _{CC} = 5 V, R _L = 350 Ω, I _F = 7.5 mA	T _A = 25°C	40	75		
						100		
	Rise Time	t _r	V _{CC} = 5 V, R _L = 350 Ω, I _F = 7.5 mA		20			
	Fall Time	t _f			5			
	Pulse Width Distortion (PWD) ³	t _{PHL-tPLH}				5	35	
	Propagation Delay Skew	t _{PSK}					40	
Common Mode Transient Immunity at High Level Output ⁴	CM _H	V _{CC} = 5 V, R _L = 350 Ω, T _A = 25°C, I _F = 0 mA, V _O > 2 V, V _{CM} = 1 kV		15	20		kV/μs	
Common Mode Transient Immunity at Low Level Output ⁴	CM _L	V _{CC} = 5 V, R _L = 350 Ω, T _A = 25°C, I _F = 7.5 mA, V _O < 0.8 V, V _{CM} = 1 kV		15	20		kV/μs	

*1 Typical values at $T_A = 25^\circ\text{C}$

*2 Because V_{OL} of 2 V or more may be output when LED current input and when output supply of $V_{CC} = 2.6\text{ V}$ or less, it is important to confirm the characteristics (operation with the power supply on and off) during design, before using this device.

*3 Test circuit for propagation delay time

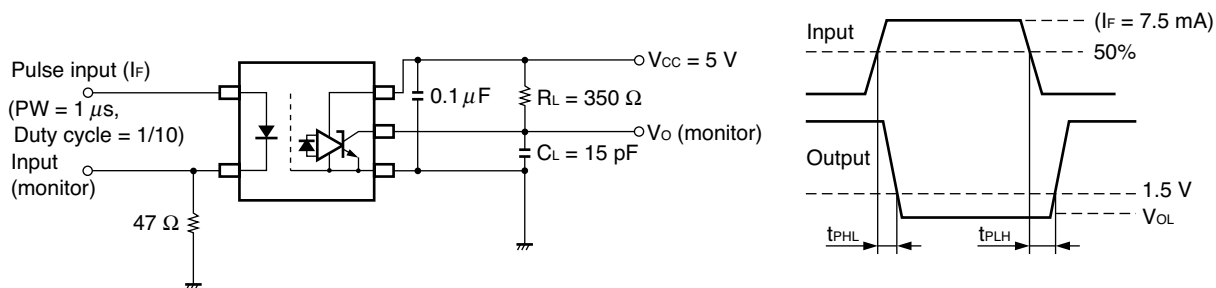

Remark C_L includes probe and stray wiring capacitance.

*4 Test circuit for common mode transient immunity

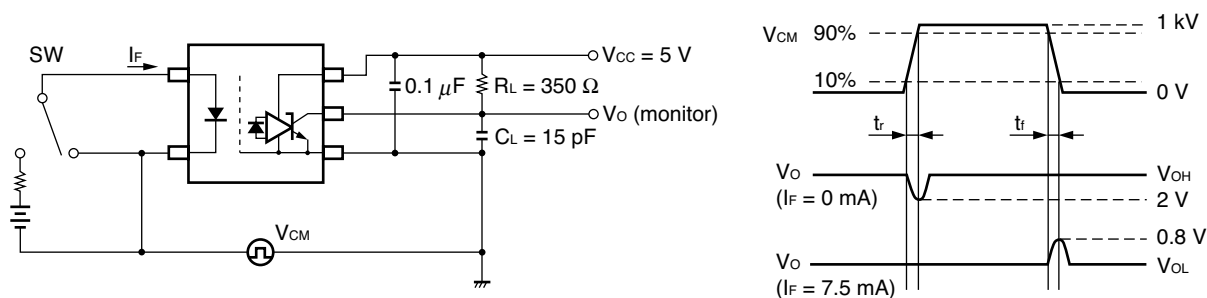

Remark C_L includes probe and stray wiring capacitance.

USAGE CAUTIONS

1. This product is weak for static electricity by designed with high-speed integrated circuit so protect against static electricity when handling.
2. By-pass capacitor of $0.1\ \mu\text{F}$ is used between V_{CC} and GND near device. Also, ensure that the distance between the leads of the photocopier and capacitor is no more than 10 mm.

TYPICAL CHARACTERISTICS ($T_A = 25^\circ\text{C}$, unless otherwise specified)

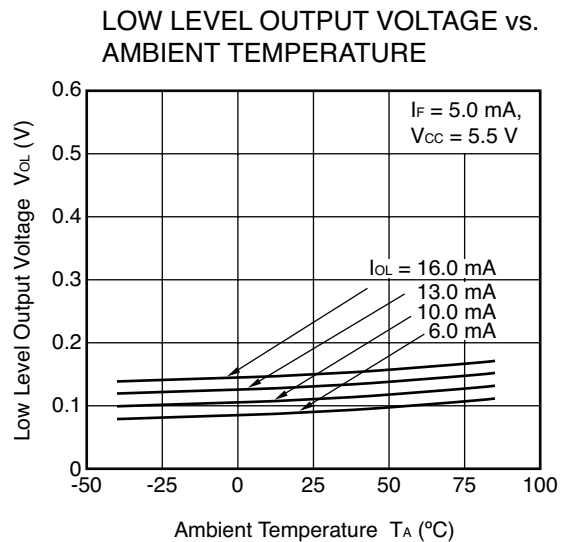
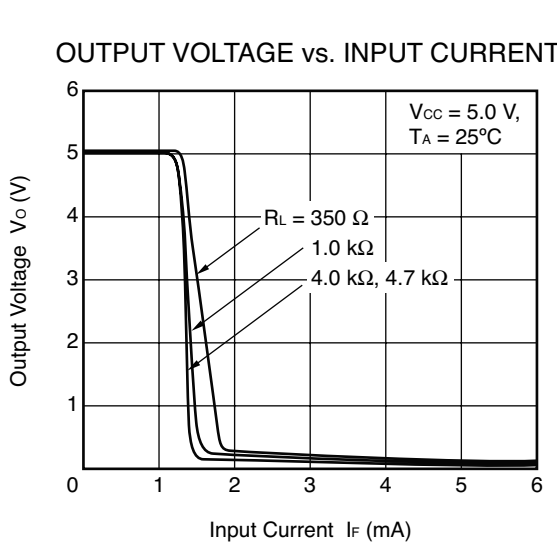
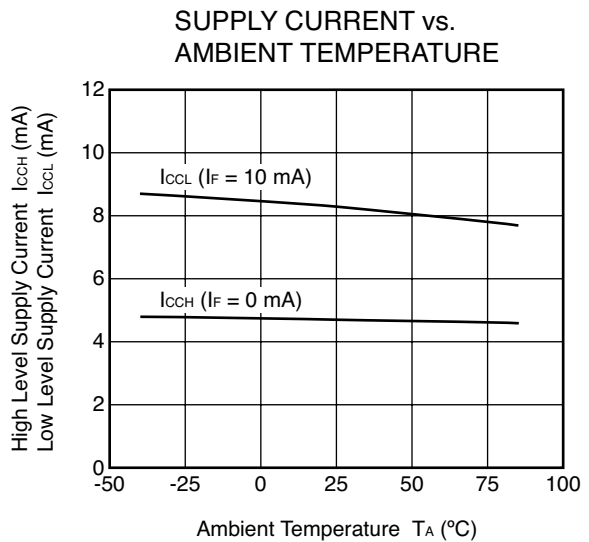
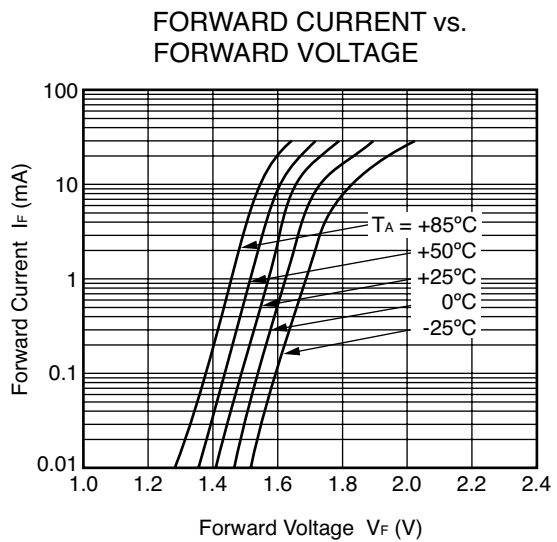
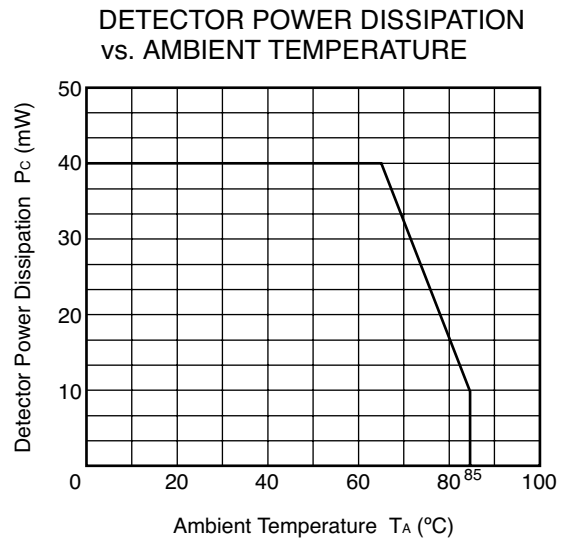
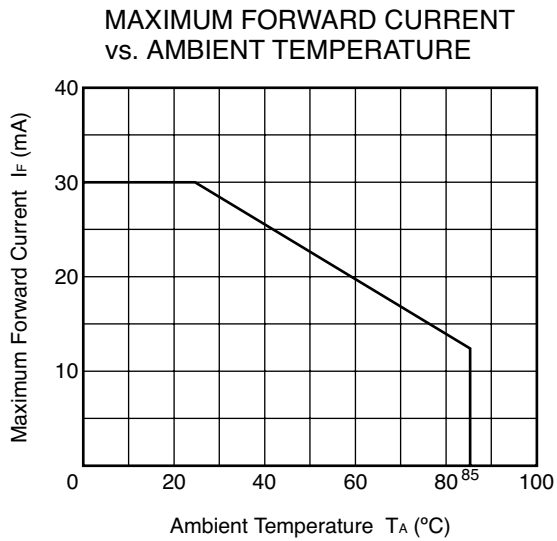

Remark The graphs indicate nominal characteristics.

THRESHOLD INPUT CURRENT vs. AMBIENT TEMPERATURE

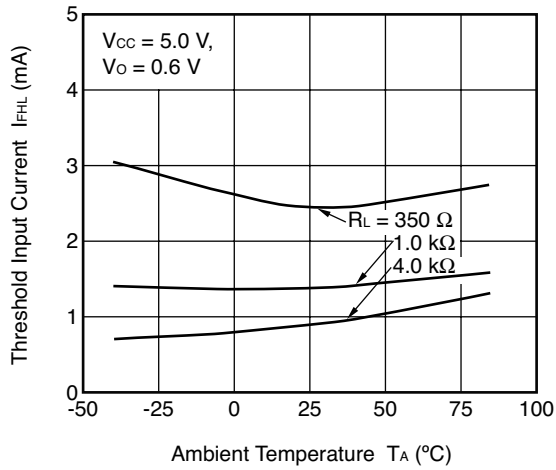

PROPAGATION DELAY TIME vs. AMBIENT TEMPERATURE

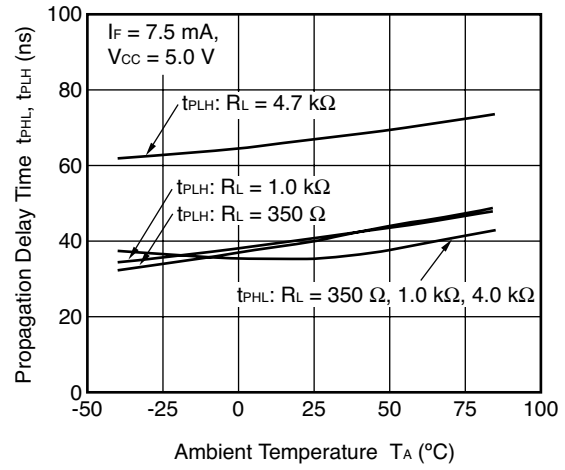

PULSE WIDTH DISTORTION vs. AMBIENT TEMPERATURE

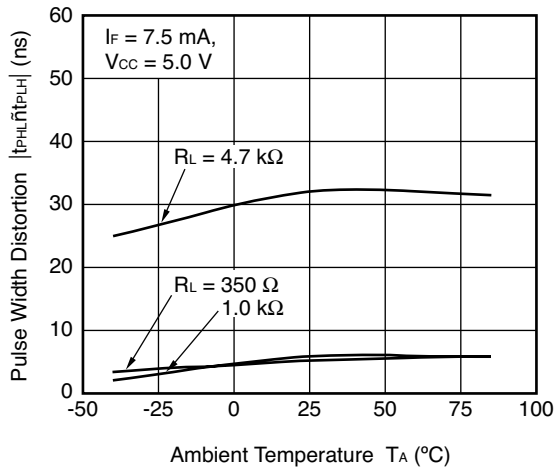

SWITCHING TIME vs. AMBIENT TEMPERATURE

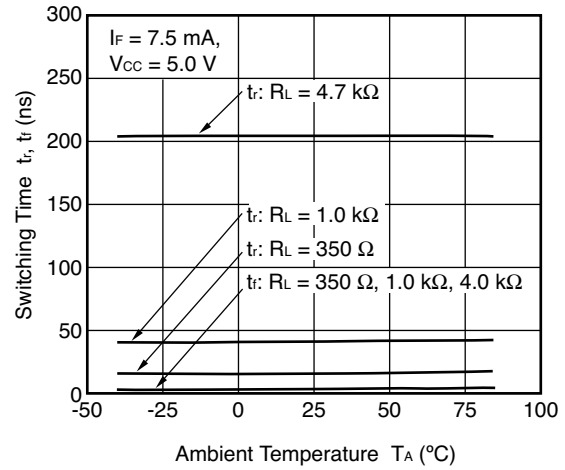

PROPAGATION DELAY TIME vs. INPUT CURRENT

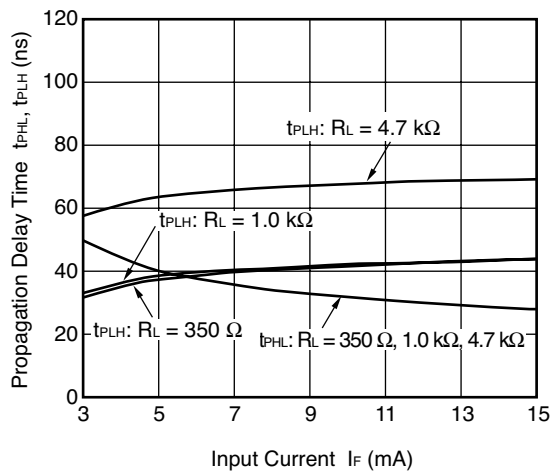

TAPING SPECIFICATIONS (UNIT:mm)

Outline and Dimensions (Tape)

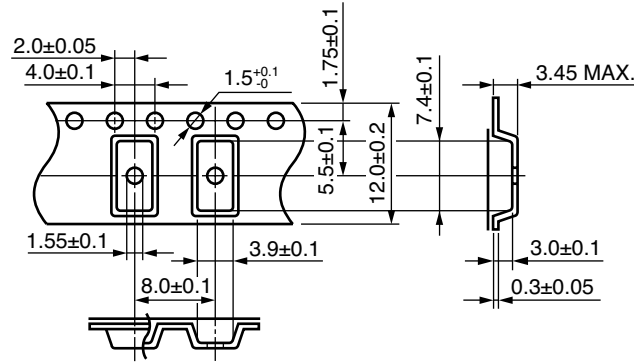

Tape Direction

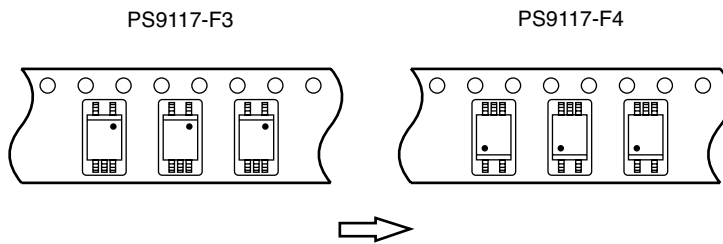

Outline and Dimensions (Reel)

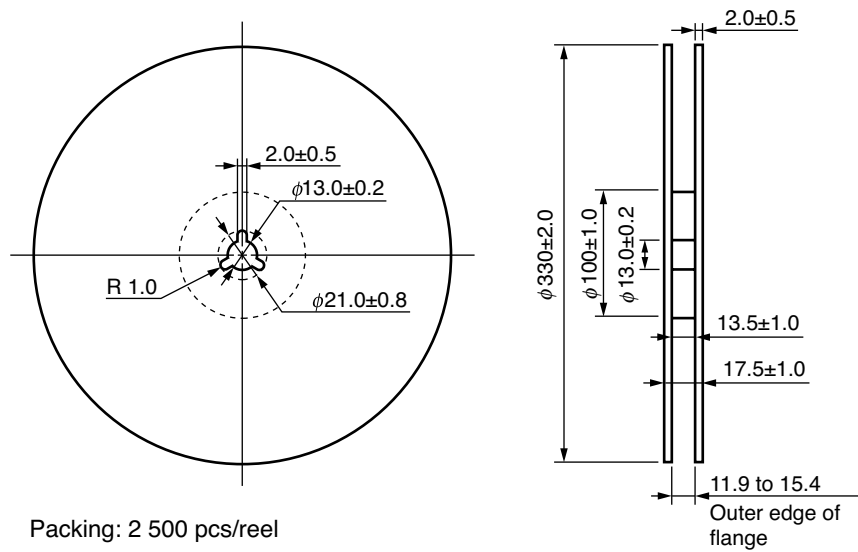

NOTES ON HANDLING

1. Recommended soldering conditions

(1) Infrared reflow soldering

- Peak reflow temperature 260°C or below (package surface temperature)
- Time of peak reflow temperature 10 seconds or less
- Time of temperature higher than 220°C 60 seconds or less
- Time to preheat temperature from 120 to 180°C 120±30 s
- Number of reflows Three
- Flux Rosin flux containing small amount of chlorine (The flux with a maximum chlorine content of 0.2 Wt% is recommended.)

Recommended Temperature Profile of Infrared Reflow

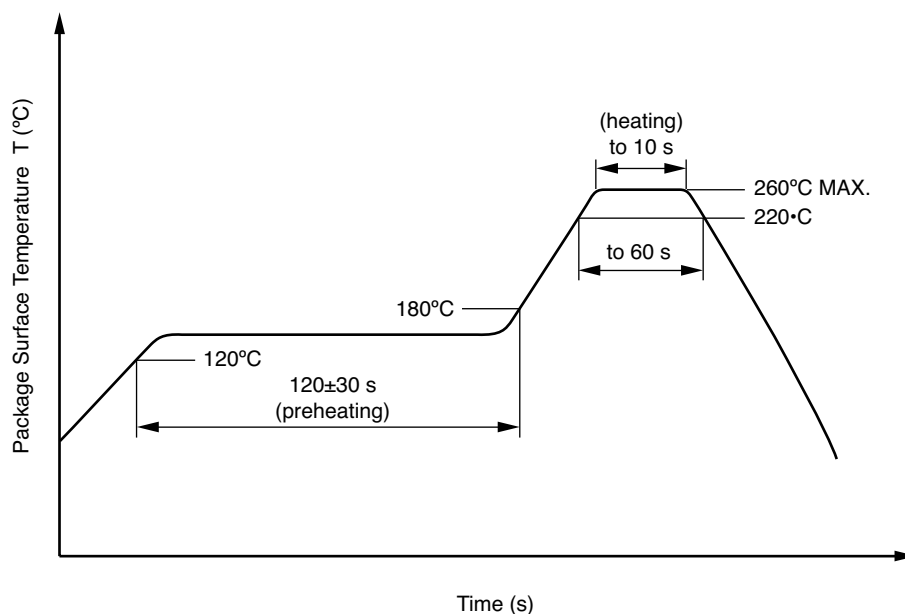

(2) Wave soldering

- Temperature 260°C or below (molten solder temperature)
- Time 10 seconds or less
- Preheating conditions 120°C or below (package surface temperature)
- Number of times One (Allowed to be dipped in solder including plastic mold portion.)
- Flux Rosin flux containing small amount of chlorine (The flux with a maximum chlorine content of 0.2 Wt% is recommended.)

(3) Soldering by Soldering Iron

- Peak Temperature (lead part temperature) 350°C or below
- Time (each pins) 3 seconds or less
- Flux Rosin flux containing small amount of chlorine (The flux with a maximum chlorine content of 0.2 Wt% is recommended.)

- (a) Soldering of leads should be made at the point 1.5 to 2.0 mm from the root of the lead
- (b) Please be sure that the temperature of the package would not be heated over 100°C

(4) Cautions

- Fluxes

Avoid removing the residual flux with freon-based and chlorine-based cleaning solvent.

2. Cautions regarding noise

Be aware that when voltage is applied suddenly between the photocoupler's input and output or between collector-emitters at startup, the output transistor may enter the on state, even if the voltage is within the absolute maximum ratings.

USAGE CAUTIONS

1. Protect against static electricity when handling.
2. Avoid storage at a high temperature and high humidity.

Life Support Applications

These NEC products are not intended for use in life support devices, appliances, or systems where the malfunction of these products can reasonably be expected to result in personal injury. The customers of CEL using or selling these products for use in such applications do so at their own risk and agree to fully indemnify CEL for all damages resulting from such improper use or sale.

CEL California Eastern Laboratories, Your source for NEC RF, Microwave, Optoelectronic, and Fiber Optic Semiconductor Devices.
4590 Patrick Henry Drive • Santa Clara, CA 95054-1817 • (408) 988-3500 • FAX (408) 988-0279 • www.cel.com

DATA SUBJECT TO CHANGE WITHOUT NOTICE

04/04/2005