

T-75-33-09



AY58116/8116T AY58136/8136T

Dual Baud Rate Generator

FEATURES

- Single +5V power supply
- On-chip crystal oscillator 8116/8136 or external frequency input 8116/8116T/8136/8136T
- Direct compatibility with UART/USRT
- Dual selectable 16x clock outputs
- High frequency reference output (Available only on 8136/8136T)
- Reprogrammable ROM allowing generation of non-standard frequencies
- TTL, MOS compatibility
- Pin for pin and functionally compatible with SMC's COM 8116/8116T/8136/8136T
- Microchip Technology Advanced N-Channel Silicon Gate Process

DESCRIPTION

The Microchip Technology AY58116/8136 Series is a very versatile family of Dual Baud Rate Generators. The AY58116/8116T and AY58136/8136T are pin for pin functionally equivalent to SMC's COM 8116/8116T and COM 8136/8136T, respectively.

The AY58116/8136 is designed to generate the full spectrum of 16 asynchronous /synchronous data communication frequencies for use with 16x and 32x UART/USRT devices.

An on-chip crystal oscillator available on the 8116 and 8136 is capable of providing a master reference frequency. Alternatively, complimentary TTL level clock signals can be input to pins 1 and 18. The 8116T and 8136T are only suitable for this external TTL reference. When using TTL outputs to drive the XTAL/EXT inputs, they should not be used to drive other TTL inputs due to excessive loading which may result in a reduction of noise immunity.

Dividers are used on the output of the oscillator/buffer which generate the output frequencies f_1 and f_2 . These dividers can divide any integer from 6 to $2^{19} + 1$, inclusive. When using an even divisor, the output will be square; an odd divisor will cause the output to be high longer than it is low by one clock period ($1/f_x$). The clock

PIN CONFIGURATIONS

18 LEAD DUAL INLINE

AY58116/8116T

Top View

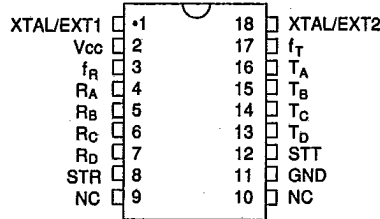

Top View

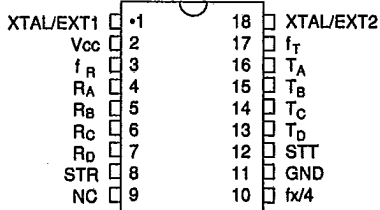

frequency (f_x) is used by the 8136/8136T to provide a high frequency output ($f_x/4$).

The 8116/8136 family allows generation of other frequencies with the use of its two divisor ROMs which contain 16 divisors, each 19 bits wide, allowing for up to 32 different divisors on custom parts.

Externally strobed data latches are used to hold the divisor select bits, $R_A - R_D$ and $T_A - T_D$. The strobe inputs, STR or STT, allow data to pass directly through the data latch when in the high state. A new frequency is initiated within 3.5 μ sec of a change in any of the four divisor select bits read by the device. Pull-up resistors are provided on the divisor select inputs which are not present on the strobe inputs.

5

PIN FUNCTIONS

Pin Number	Signal	Function
1	XTAL/EXT1	Input is either one pin of the crystal package or one polarity of the external input.
2	V _{CC}	Positive power supply - normally +5V.
3	f _R	This output runs at a frequency selected by the Receiver divisor select data bits.
4-7	R _A , R _B , R _C , R _D	These inputs, as shown in Table 1, select the receiver output frequency, f _R .
8	STR	A high level input strobe loads the receiver data (R _A , R _B , R _C , R _D) into the receiver divisor select register. This input may be strobed or hard-wired to a high level.
9	NC	
10	NC or f _x /4	NC (8116/8116T), f _x /4 (8136/8136T).
11	GND	Ground.
12	STT	A high level input strobe loads the transmitter data (T _A , T _B , T _C , T _D) into the transmitter divisor select register. This input may be strobed or hard-wired to a high level.
13-16	T _D , T _C , T _B , T _A	These inputs, as shown in Table 1, select the transmitter output frequency, f _T .
17	f _T	This output runs at a frequency selected by the transmitter divisor select data bits.
18	XTAL/EXT2	This input is either the other pin of the crystal package or the other polarity of the external input.

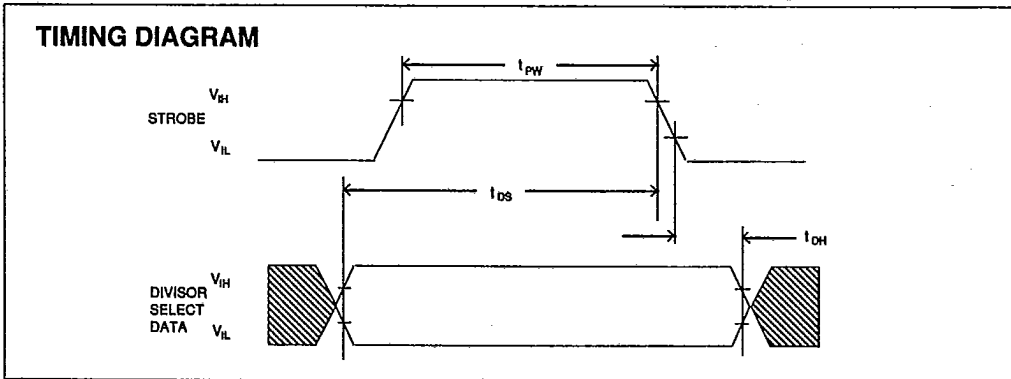

T-75-33-09

ELECTRICAL CHARACTERISTICS

Maximum Ratings*

Operating Temperature Range 0°C to +70°C
 Storage Temperature Range -55°C to +150°C
 Positive Voltage on any Pin,
 with respect to ground +8.0V
 Negative Voltage on any Pin,
 with respect to ground -0.3V

* Exceeding these ratings could cause permanent damage to the device. This is a stress rating only and functional operation of this device at these conditions is not implied. Operating ranges are specified in Standard Conditions. Exposure to absolute maximum rating conditions for extended periods may affect device reliability.

Data labeled "typical" is presented for design guidance only and is not guaranteed.

Standard Conditions (unless otherwise noted):

T_A = 0°C to +70°C, V_{CC} = +5V ±5%

DC CHARACTERISTICS

Characteristic	Sym	Min	Typ	Max	Unit	Conditions
Input Voltage Levels						
Low Level	V _{IL}	-	-	0.8	V	excluding XTAL inputs
High Level	V _{IH}	2.0	-	-	V	
Output Voltage Levels						
Low Level	V _{OL}	-	-	0.4	V	I _{OL} = 1.6mA, for f _X /4, I _{OL} = 3.2mA, for f _R , f _T I _{OH} = -100µA
				0.4	V	
High Level	V _{OH}	3.5	-	-	V	
Input Current						
Low Level	I _{IL}	-	-	-0.1	mA	V _{IN} = GND, R _A -R _D & T _A -T _D only
Input Capacitance All inputs			5	10	pF	V _{IN} = GND, excluding XTAL inputs
Power Supply Current	I _{CC}	-	-	50	mA	

AC CHARACTERISTICS

Characteristic	Sym	Min	Typ	Max	Unit	Conditions
Clock Frequency	f _X	0.01	-	5.1	MHz	XTAL/EXT, 50% Duty Cycle ±5%
Strobe Pulse Width	t _{PW}	150	-	DC	ns	
Input Set-up Time	t _{DS}	200	-	-	ns	
Input Hold Time	t _{DH}	50	-	-	ns	
Strobe to new Frequency Delay		-	-	3.5	µs	

CRYSTAL SPECIFICATIONS

Temperature range 0°C to +70°C
 Series resistance ≤50Ω
 Series resonant
 Overall tolerance ± 0.01%



AY58116/8116T
AY58136/8136T

T-75-33-09

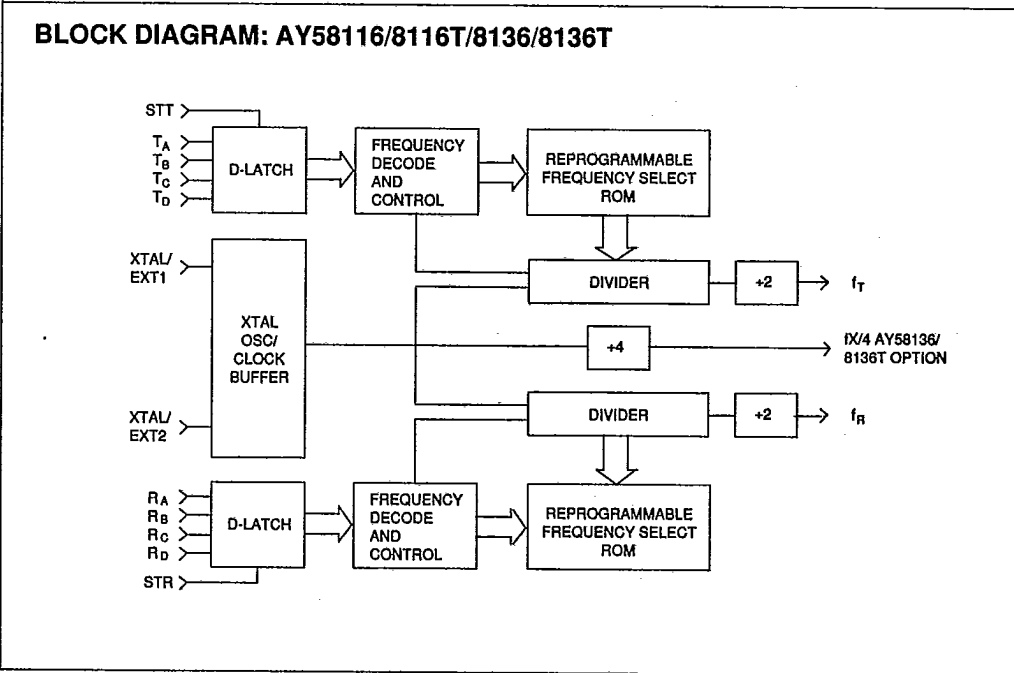
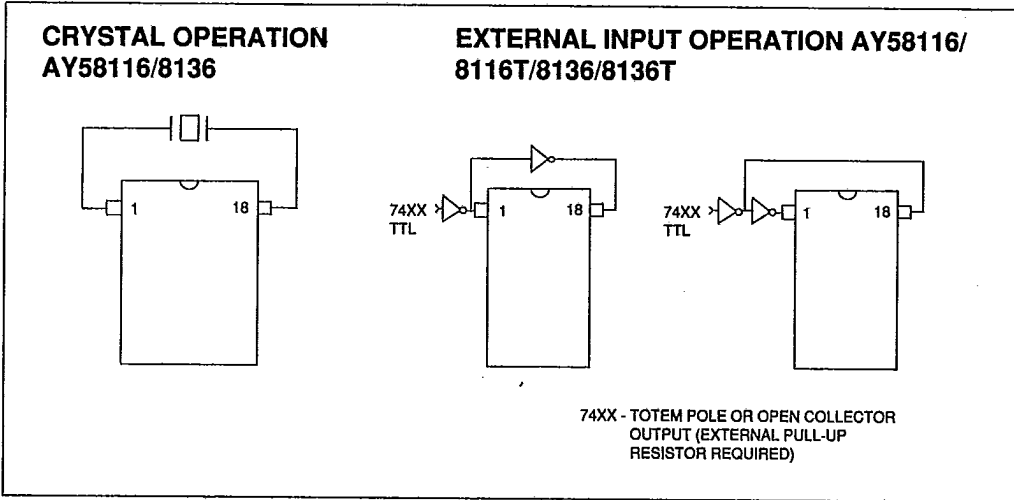

Table 1 Output Frequency AY58116/8116T/8136/8136T
REFERENCE FREQUENCY = 5.068800 MHz

Divisor Select DCBA	Desired Baud Rate	Clock Factor	Desired Frequency (KHz)	Divisor	Actual Baud Rate	Actual Frequency (KHz)	Deviation
0000	50.00	16X	0.80000	6336	50.00	0.800000	0.0000%
0001	75.00	16X	1.20000	4224	75.00	1.200000	0.0000%
0010	110.00	16X	1.76000	2880	110.00	1.760000	0.0000%
0011	134.50	16X	2.15200	2355	134.52	2.152357	0.0166%
0100	150.00	16X	2.40000	2112	150.00	2.400000	0.0000%
0101	300.00	16X	4.80000	1056	300.00	4.800000	0.0000%
0110	600.00	16X	9.60000	528	600.00	9.600000	0.0000%
0111	1200.00	16X	19.20000	264	1200.00	19.200000	0.0000%
1000	1800.00	16X	28.80000	176	1800.00	28.800000	0.0000%
1001	2000.00	16X	32.00000	158	2005.06	32.081013	0.2532%
1010	2400.00	16X	38.40000	132	2400.00	38.400000	0.0000%
1011	3600.00	16X	57.60000	88	3600.00	57.600000	0.0000%
1100	4800.00	16X	76.80000	66	4800.00	76.800000	0.0000%
1101	7200.00	16X	115.20000	44	7200.00	115.200000	0.0000%
1110	9600.00	16X	153.60000	33	9600.00	153.600000	0.0000%
1111	19200.00	16X	307.20000	16	19800.00	316.800000	3.1250%

5

Table 1 (Cont.) Output Frequency AY58116/8116T/8136/8136T-005 *T-75-33-09*
REFERENCE FREQUENCY = 4.915200 MHz

Divisor Select DCBA	Desired Baud Rate	Clock Factor	Desired Frequency (KHz)	Divisor	Actual Baud Rate	Actual Frequency (KHz)	Deviation
0000	50.00	16X	0.80000	6144	50.00	0.800000	0.0000%
0001	75.00	16X	1.20000	4096	75.00	1.200000	0.0000%
0010	110.00	16X	1.76000	2793	109.93	1.758983	0.0100%
0011	134.50	16X	2.15200	2284	134.50	2.152000	0.0000%
0100	150.00	16X	2.40000	2048	150.00	2.400000	0.0000%
0101	300.00	16X	4.80000	1024	300.00	4.800000	0.0000%
0110	600.00	16X	9.60000	512	600.00	9.600000	0.0000%
0111	1200.00	16X	19.20000	256	1200.00	19.200000	0.0000%
1000	1800.00	16X	28.80000	171	1796.49	28.743859	0.1949%
1001	2000.00	16X	32.00000	154	1994.81	31.916883	0.2597%
1010	2400.00	16X	38.40000	128	2400.00	32.000000	0.0000%
1011	3600.00	16X	57.60000	85	3614.11	57.825882	0.3921%
1100	4800.00	16X	76.80000	64	4800.00	76.800000	0.0000%
1101	7200.00	16X	115.20000	43	7144.19	114.306976	0.7751%
1110	9600.00	16X	153.60000	32	9600.00	153.600000	0.0000%
1111	19200.00	16X	307.20000	16	19200.00	307.200000	0.0000%

T-75-33-09

Table 1 (Cont.) Output Frequency AY58116/8116T/8136/8136T-006

REFERENCE FREQUENCY = 5.068800 MHz

Divisor Select DCBA	Desired Baud Rate	Clock Factor	Desired Frequency (KHz)	Divisor	Actual Baud Rate	Actual Frequency (KHz)	Deviation
0000	50.00	32X	1.60000	3168	50.00	1.60000	0.0000%
0001	75.00	32X	2.40000	2112	75.00	2.40000	0.0000%
0010	110.00	32X	3.52000	1440	110.00	3.52000	0.0000%
0011	134.50	32X	4.30400	1177	134.52	4.30600	0.0600%
0100	150.00	32X	4.80000	1056	150.00	4.80000	0.0000%
0101	200.00	32X	6.40000	792	200.00	6.40000	0.0000%
0110	300.00	32X	9.60000	528	300.00	9.60000	0.0000%
0111	600.00	32X	19.20000	264	600.00	19.20000	0.0000%
1000	1200.00	32X	38.40000	132	1200.00	38.40000	0.0000%
1001	1800.00	32X	57.60000	88	1800.00	57.60000	0.0000%
1010	2400.00	32X	76.80000	66	2400.00	76.80000	0.0000%
1011	3600.00	32X	115.20000	44	3600.00	115.20000	0.0000%
1100	4800.00	32X	153.60000	33	4800.00	153.60000	0.0000%
1101	7200.00	32X	230.40000	22	7200.00	230.40000	0.0000%
1110	9600.00	32X	307.20000	16	9900.00	316.80000	3.1250%
1111	19200.00	32X	614.40000	8	19800.00	633.60000	3.1250%

5

AY58116/8116T
AY58136/8136T

6103201 0004966 5 T-75-33-09

MICROCHIP TECHNOLOGY INC 22E D

SALES AND SUPPORT

To order or to obtain information, e.g., on pricing or delivery, please use the listed part numbers, and refer to the factory or the listed sales offices.

PART NUMBERS

AY5 81X6 T/P XXX

