

Description

The YB1517 is a Current-mode PWM step-up DC-DC converter. It can drive up to 18V at 3.0V input and 30V at 5.0V input. The 1 MHz switching frequency allows it to work with tiny external components, therefore minimize the footprint and cost in space consideration products.

One of the major applications for YB1517 is in the dc to dc converter and OLED power supply and TFT panel power supply.

When using YB1517 for white LED driving, it is not recommended to control LED brightness by applying a PWM signal to the CTRL pin, because the built-in soft-start circuit might interfere the start-up operation of YB1517 and cause lower brightness. It operates as current source to drive up to 5 white LEDs in series at 3.0V input and up to 8 white LEDs at 5.0V input. Series connecting of the LEDs provides identical LED currents resulting in uniform brightness and eliminating the need for ballast resistors. The light intensity of these LEDs is proportional to the current passing through them.

YB1517 has integrated Latched Over Voltage Protection that prevents damage to the device in case of a high impedance output due to faulty LED or open circuit caused by abnormal conditions.

Features

- 900 KHz current-mode PWM converter
- Built-in internal switch
- Adjustable output voltage up to 30V
- 2.7V to 16V input range
- <1uA shutdown current
- Internal Soft Start
- Drives up to 5 white LEDs
- Tiny Inductor and Capacitors allowed
- Small 5-Lead SOT-23 package
- 220mV Low Reference Voltage

Applications

- LCD Display Module
- White LED Backlighting
- PDAs, GPS terminals
- Digital Cameras
- Cellular Phone
- Electronic Books
- Portable Applications

Typical Application Circuit

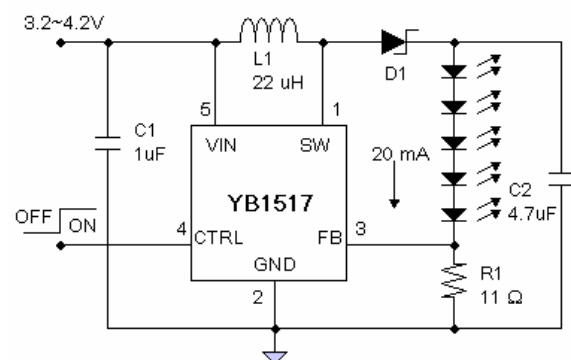

Figure 1 : White LED Driver

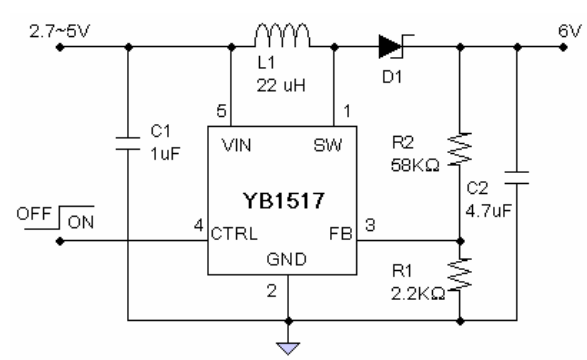

Figure 2 : DC-to-DC Converter

Pin Configuration

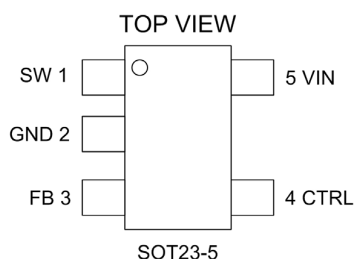

Figure 3 : YB1517 Pin Configuration

Pin Description

Table 1

Pin	NAME	Description
1	SW	Switching Pin. This is the collector of the internal NPN power switch. Connect to inductor and diode. Minimize the metal trace area connected to this pin to reduce EMI.
2	GND	Ground Pin. Connect directly to local ground plane.
3	FB	Feedback Pin. Reference voltage is 220mV. When connecting LEDs and a resistor at this pin, LED current is determined by the resistance and CTRL voltage.
4	CTRL	Shutdown Pin and Dimming Control pin. VCTRL > 1.8V generates full-scale LED current VCTRL < 0.4V chip is off Switching from 0.4V to 2.0V, PWM duty cycle controls the LED current
5	VIN	Input Supply Pin. Bypass this pin with a capacitor as close to the device as possible

Ordering Information

Table 2

Order Number	Supplied as	Package Marking
YB1517ST25	3000 units Tape & Reel	Y58 F

Absolute Maximum Ratings

VIN	20V
SW Voltage	35V
FB Voltage	5V
CTRL Voltage.....	5V
Maximum Junction Temp,TJ (not 2)	150°C
Lead Temperature (Soldering 10 sec).....	250°C
Thermal Resistance (SOT-25, θ JA).....	250°C/W
Internal Power Dissipation (SOT-25, PD).....	0.4W

Recommended Operating Conditions

Operating Temperature (note 3)	-40°C~85°C
Supply Voltage	2.7 V~16V
SW Voltage	30V
ESD Susceptibility (HBM).....	2KV
ESD Susceptibility (MM).....	200V

Electricity Characteristics

Table 3 (TA=25°C, Vin=3.3V, L=22uH, Cin=1uF, Cout=4.7uF unless otherwise noted)

Symbol	Function Parameter	Test Conditions	Min	Typ	Max	Units
Vin	Input Voltage Range		2.7		16	V
IQ (Quiescent Current)	Not Switching	VFB = 0.5V	1.2	1.5	1.7	mA
	Shutdown	CTRL = 0V		0.3	1	uA
VFB	Feedback Voltage	Iout=20mA, Vout = 6V Circuit of Figure 2	210	220	230	mV
ICL	Switch Current Limit	100% duty cycle	850	900	1000	mA
		40% duty cycle		400		mA
IB	FB Pin Bias Current	VFB=220mV			1	uA
FRSW	Switching Frequency		850	900	950	KHz
DTMX	Maximum Duty Cycle				85	%
DTMN	Minimum duty cycle		20		25	%
VSAT	Switch Vcesat	At Isw = 200mA			180	mV
ILKG	Switch Leakage Current	Ctrl = 0.5V			1	uA
VCTL	VCTRL for Full LED current	Full On	1.7			V
		Full Off			0.3	V
ICTL	CTRL Pin Bias Current	Ctrl = 2V		40		uA
OVP	Over Voltage Protection			34		V
θ JA	Thermal Resistance			220		°C/W

Note:

Absolute maximum ratings are limits beyond which damage to the device may occur. The maximum allowable, power dissipation at any ambient temperature is calculated using: PD(MAX)= [TJ(max)-TA]/ θ JA .

Typical Characteristics

Output Voltage vs Output Load

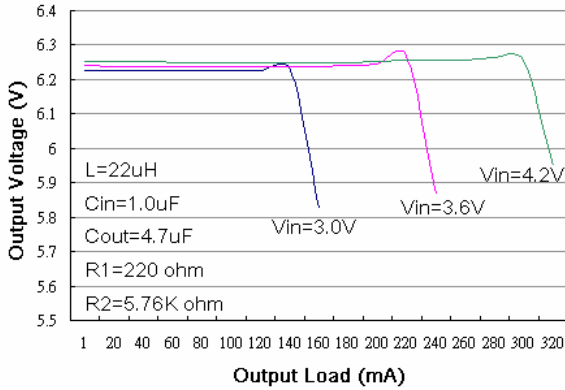

Output Voltage vs Input Voltage

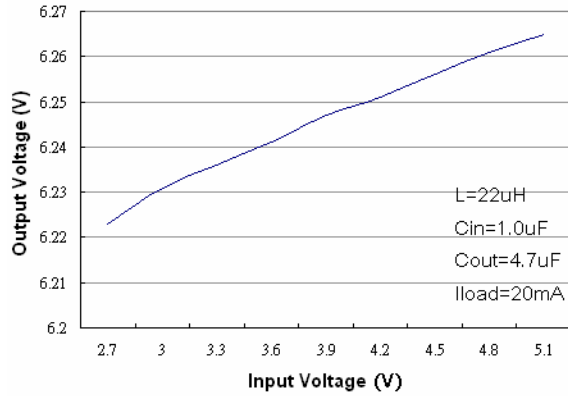

Efficiency vs Output Load (1)

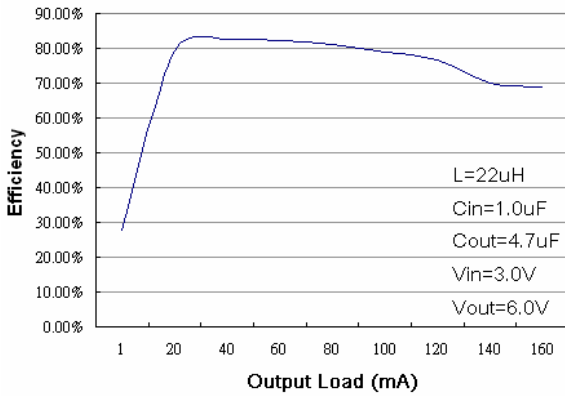

Efficiency vs Output Load (2)

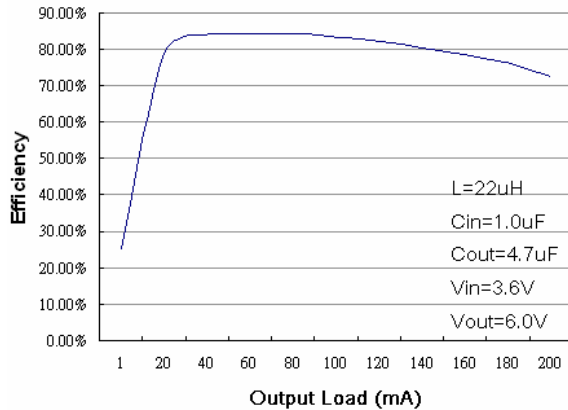

Efficiency vs Output Load (3)

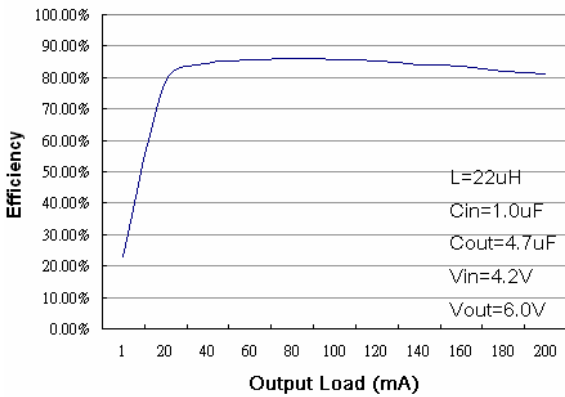

Frequency vs Input Voltage

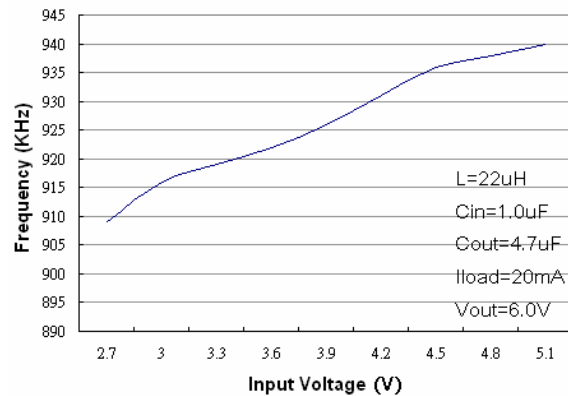

Output Voltage vs Output Load

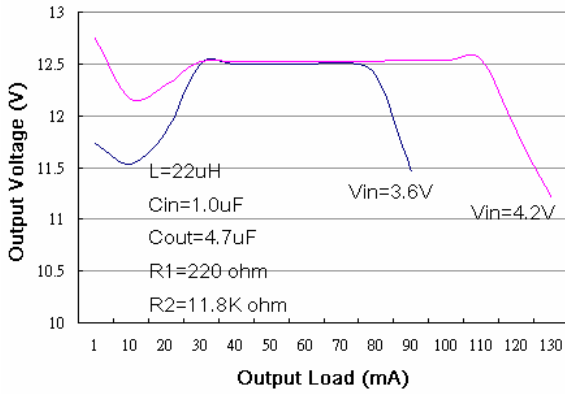

Frequency vs Input Voltage

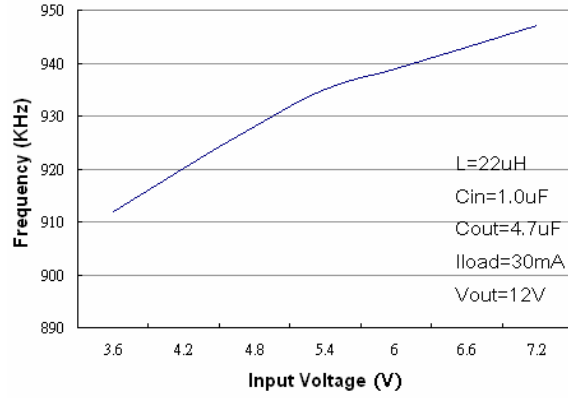

Efficiency vs Output Load (1)

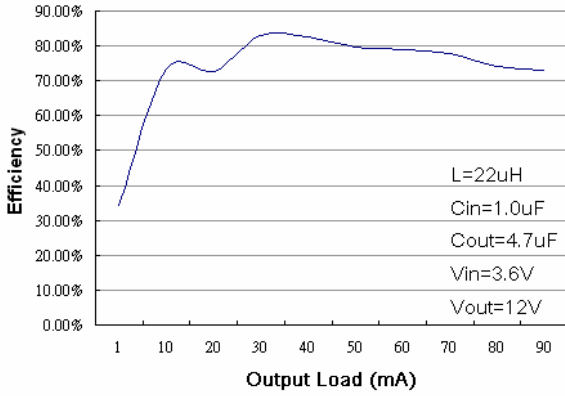

Output Voltage vs Input Voltage

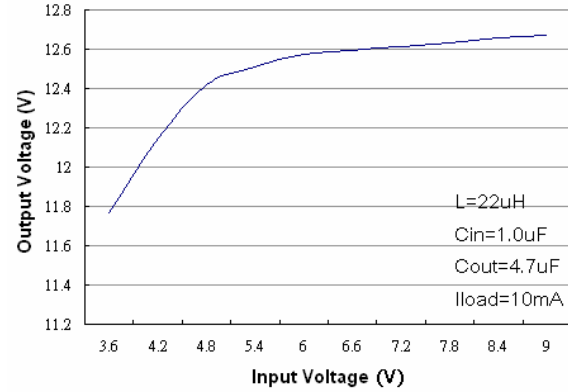

Efficiency vs Output Load (2)

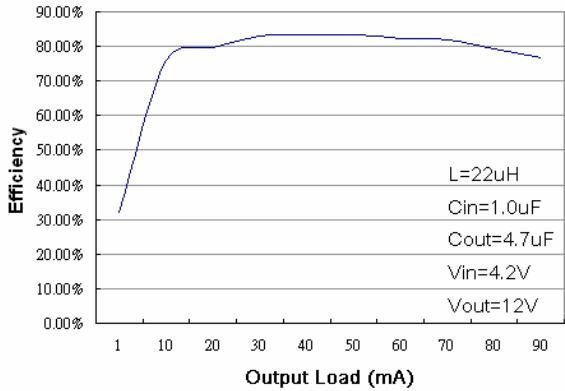

VFB Voltage vs Temperature

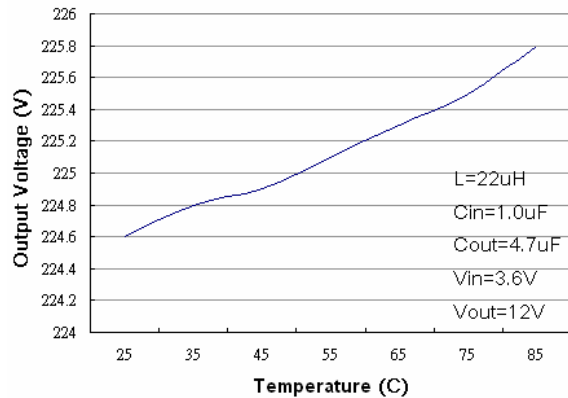

Output Waveform at 20 mA Load (1)

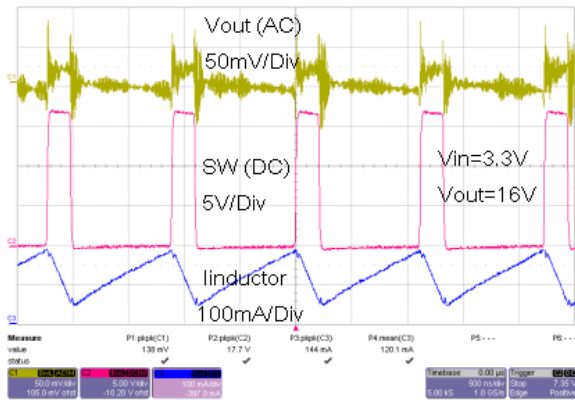

Output Waveform at 20 mA Load (2)

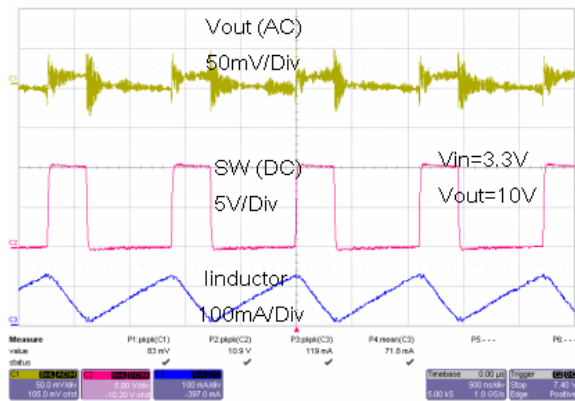

Soft-Start Waveform

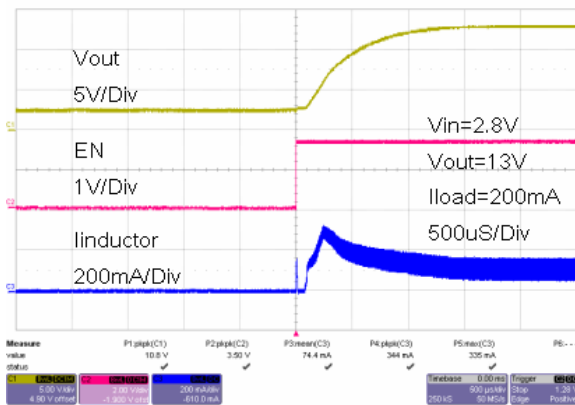

Functional Block

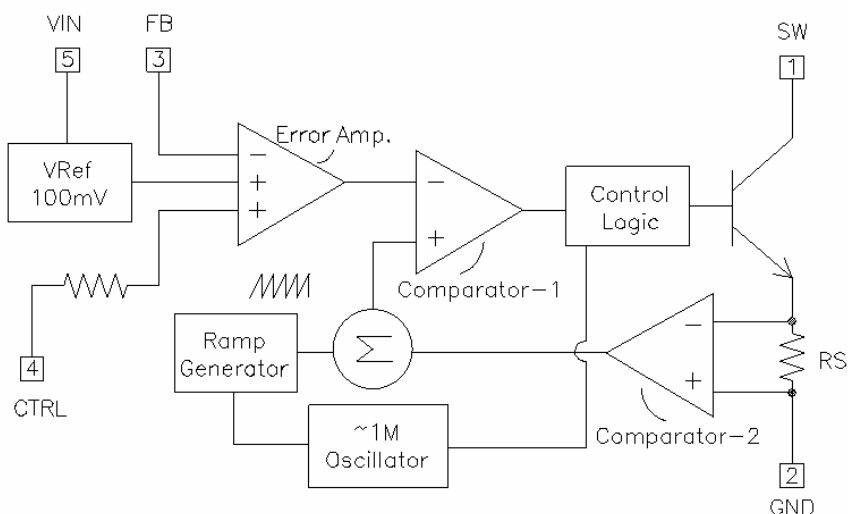

Figure 3: YB1517 Block Diagram

Operation

The YB1517 uses a constant frequency, current mode control scheme to regulate the output voltage. Its operation can be understood by referring to the block diagram in Figure 3. At the start of each oscillator cycle, a voltage proportional to the switch current is added to a ramp output and the resulting sum is fed into the positive terminal of the PWM comparator (comparator-1). When this voltage exceeds the level of the comparator negative input, the peak current has been reached, and the SR latch (in Control Logic) is reset and turns off the power switch. The voltage at the negative input of the comparator comes from the output of the error amplifier. The error amplifier sets the correct peak current level to keep the output in regulation. If the error amplifier's output increases, more current is delivered to the output; if it decreases, less current is delivered.

Application Information

Soft Start and Current Limit

The internal soft start circuit minimizes the inrush current during turning on YB1517. The maximum switch current is limited to about 900 mA by the chip.

Over Voltage Protection

The YB1517 has an internal over voltage protection circuit which also acts as an open-circuit protection. In the cases of open circuit or the LEDs failure, the LEDs are disconnected from the circuit, and the feedback voltage will be zero. The YB1517 will then switch to a high duty cycle resulting in a high output voltage, which may cause SW pin voltage to exceed its maximum 34V rating. The YB1517 will shutdown automatically until

input condition changes to bring it out of the shutdown mode.

Inductor Selection

A 22 μ H inductor is recommended for most applications to the dc to dc converter and OLED supply and TFT panel power supply . Although small size and high efficiency are major concerns, the inductor should have low core losses at 1MHz and low DCR (copper wire resistance).

Diode Selection

To maintain high efficiency, the average current rating of the Schottky diode should be large than the peak inductor current, IPK. Schottky diode with a low forward drop and fast switching speeds are ideal for increase efficiency in portable application. Choose a reverse breakdown of the Schottky diode large than the output voltage.

Capacitor Selection

Choose low ESR capacitors for the output to minimize output voltage ripple. Multilayer capacitors are a good choice for this as well. A 4.7 μ F capacitor is sufficient for most applications. For additional bypassing, a 100nF ceramic capacitor can be used to shunt high frequency ripple on the input. The input bypass capacitor Cin, as shown in Figure 1, must be placed close to the IC. This will reduce copper trace resistance which affects input voltage ripple of the IC. For additional input voltage filtering, a 100nF bypass capacitor can be placed in

parallel with Cin to shunt any high frequency noise to ground. The output capacitor, Cout, should also be placed close to the IC. Any copper trace connections for the Cout capacitor can increase the series resistance, which directly effect output voltage ripple.

The feedback network, resistor R2 should be kept close to the FB pin to minimize copper trace connections that can inject noise into the system. The ground connection for the feedback resistor network should connect directly to an analog ground plane. The analog ground plane should tie directly to the GND pin. If no analog ground plane is available, the ground connection for the feedback network should tie directly to the GND pin. Trace connections made to the inductor and Schottky diode should be minimized to reduce power dissipation and increase overall efficiency.

Figure 4 : Typical Application Circuit

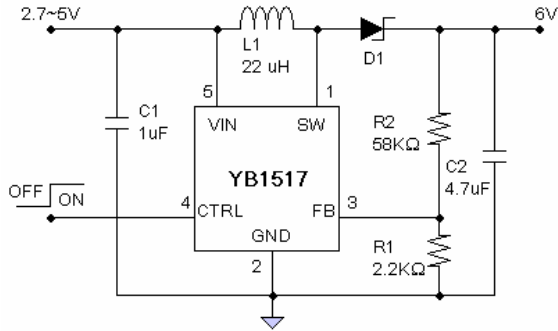
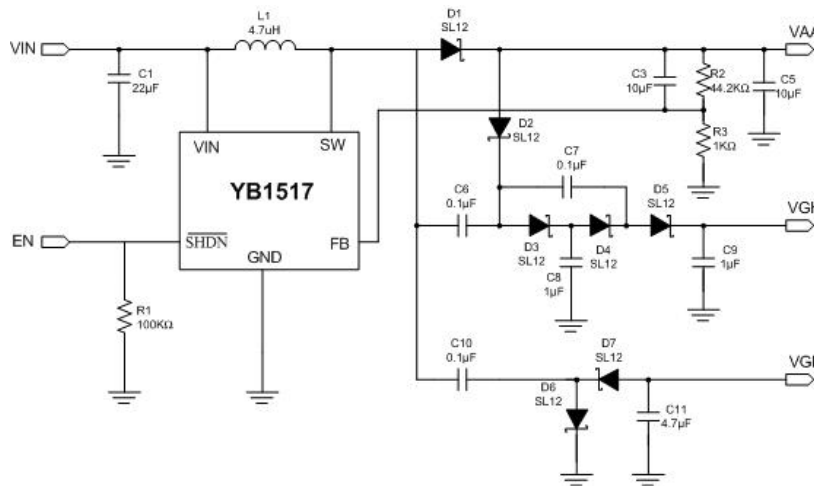
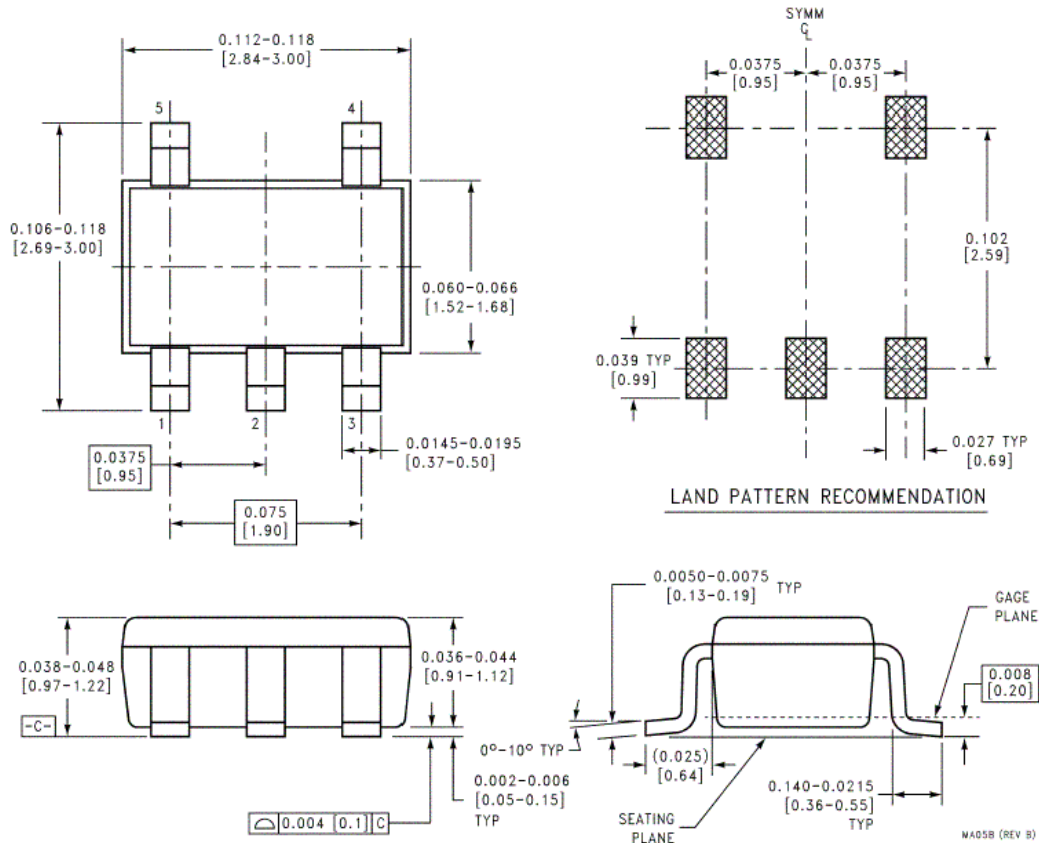

Figure 5 : TFT Panel Power Application Circuit



Package Description



All the contains in this datasheet are not assuming any responsibility for use of any circuitry described no circuit patent license are implied and Yobon reserves the right at any time without notice to change said circuitry and specifications.

Yobon Inc. would like to receive your feedback with your recommends and suggestions that is always welcome and with our appreciations.