

## Dual and Quad, JFET Input Precision High Speed Op Amps

### FEATURES

- 14V/μs Slew Rate 10V/μs Min.
- 5MHz Gain-Bandwidth Product
- Fast Settling Time 1.3μs to 0.02%
- 150μV Offset Voltage (LT1057) 450μV Max.
- 180μV Offset Voltage (LT1058) 600μV Max.
- 2μV/°C V<sub>OS</sub> Drift 7μV/°C Max.
- 50pA Bias Current at 70°C
- Low Voltage Noise 13nV/√Hz @ 1kHz  
26nV/√Hz @ 10Hz

### APPLICATIONS

- Precision, High Speed Instrumentation
- Fast, Precision Sample and Hold
- Logarithmic Amplifiers
- D/A Output Amplifiers
- Photodiode Amplifiers
- Voltage to Frequency Converters
- Frequency to Voltage Converters

### DESCRIPTION

The LT1057 is a matched JFET input dual op amp in the industry standard 8 pin configuration, featuring a combination of outstanding high speed and precision specifications. It replaces all the popular bipolar and JFET input dual op amps. In particular, the LT1057 upgrades the performance of systems using the LF412A and OP-215 JFET input duals.

The LT1058 is the lowest offset quad JFET input operational amplifier in the standard 14 pin configuration. It offers significant accuracy improvement over presently available JFET input quad operational amplifiers. It can replace four single precision JFET input op amps, while saving board space, power dissipation and cost.

Both the LT1057 and LT1058 are available in all standard packages: plastic and hermetic DIP and (LT1057 only) metal can.

**2**

**Current Output, High Speed, High Input Impedance Instrumentation Amplifier**

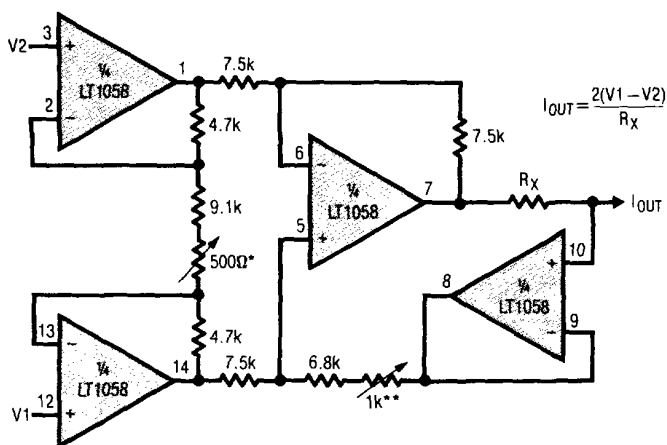

\*GAIN ADJUST  
 \*\*COMMON-MODE REJECTION ADJUST  
 BANDWIDTH ≈ 2MHz

**Distribution of Offset Voltage (All Packages, LT1057 and LT1058)**

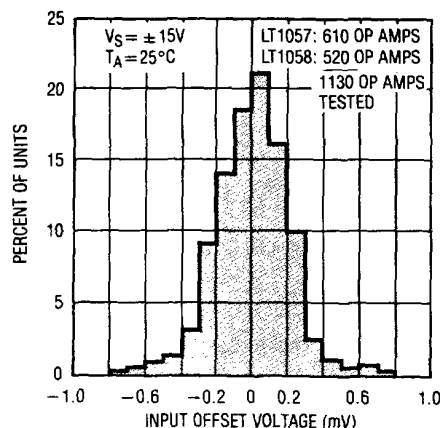

**ABSOLUTE MAXIMUM RATINGS**

Supply Voltage ..... ± 20V  
 Differential Input Voltage ..... ± 40V  
 Input Voltage ..... ± 20V  
 Output Short Circuit Duration ..... Indefinite  
 Operating Temperature Range  
   LT1057AM/LT1057M/  
   LT1058AM/LT1058M ..... - 55°C to 125°C  
   LT1057AC/LT1057C/  
   LT1058AC/LT1058C ..... 0°C to 70°C  
 Storage Temperature Range  
   All Devices ..... - 65°C to 150°C  
 Lead Temperature (Soldering, 10 sec.) ..... 300°C

**PACKAGE/ORDER INFORMATION**

TOP VIEW	ORDER PART NO.
<p>METAL CAN H PACKAGE</p>	LT1057AMH LT1057MH LT1057ACH LT1057CH
<p>HERMETIC DIP J8 PACKAGE PLASTIC DIP N8 PACKAGE</p>	LT1057AMJ8 LT1057MJ8 LT1057ACJ8 LT1057CJ8 LT1057ACN8 LT1057CN8
<p>HERMETIC DIP J14 PACKAGE PLASTIC DIP N14 PACKAGE</p>	LT1058AMJ LT1058MJ LT1058ACJ LT1058CJ LT1058ACN LT1058CN

**ELECTRICAL CHARACTERISTICS**  $V_S = \pm 15V, T_A = 25^\circ C, V_{CM} = 0V$  unless otherwise noted. (Note 1)

SYMBOL	PARAMETER	CONDITIONS	LT1057AM/LT1058AM LT1057AC/LT1058AC			LT1057M/LT1058M LT1057C/LT1058C			UNITS
			MIN	TYP	MAX	MIN	TYP	MAX	
$V_{OS}$	Input Offset Voltage			150 180	450 600		200 250	800 1000	$\mu V$ $\mu V$
$I_{OS}$	Input Offset Current	Fully Warmd Up		3	40		4	50	pA
$I_b$	Input Bias Current	Fully Warmd Up		± 5	± 50		± 7	± 75	pA
	Input Resistance-Differential			10 <sup>12</sup>			10 <sup>12</sup>		$\Omega$
	-Common-Mode	$V_{CM} = -11V$ to 8V $V_{CM} = 8V$ to 11V		10 <sup>12</sup> 10 <sup>11</sup>			10 <sup>12</sup> 10 <sup>11</sup>		$\Omega$ $\Omega$
	Input Capacitance			4			4		pF
$e_n$	Input Noise Voltage	0.1Hz to 10Hz		2.0 2.4			2.1 2.5		$\mu V_{p-p}$ $\mu V_{p-p}$
$e_n$	Input Noise Voltage Density	$f_0 = 10Hz$ $f_0 = 1kHz$ (Note 2)		26 13	22		28 14	24	$nV/\sqrt{Hz}$ $nV/\sqrt{Hz}$
$i_n$	Input Noise Current Density	$f_0 = 10Hz, 1kHz$ (Note 3)		1.5	4		1.8	6	$fA/\sqrt{Hz}$
$A_{VOL}$	Large Signal Voltage Gain	$V_O = \pm 10V, R_L = 2k$ $V_O = \pm 10V, R_L = 1k$	150 120	350 250		100 80	300 220		V/mV V/mV
	Input Voltage Range		± 10.5	14.3 - 11.5		± 10.5	14.3 - 11.5		V
CMRR	Common-Mode Rejection Ratio		86 84	100 98		82 80	98 96		dB dB
PSRR	Power Supply Rejection Ratio	$V_S = \pm 10V$ to ± 18V	88	103		86	102		dB
$V_{OUT}$	Output Voltage Swing	$R_L = 2k$	± 12	± 13		± 12	± 13		V

**ELECTRICAL CHARACTERISTICS**  $V_S = \pm 15V, T_A = 25^\circ C, V_{CM} = 0V$  unless otherwise noted. (Note 1)

SYMBOL	PARAMETER	CONDITIONS	LT1057AM/LT1058AM LT1057AC/LT1058AC			LT1057M/LT1058M LT1057C/LT1058C			UNITS
			MIN	TYP	MAX	MIN	TYP	MAX	
SR	Slew Rate		10	14		8	13		V/ $\mu$ s
GBW	Gain-Bandwidth Product	f = 1MHz (Note 5)	3.5	5		3	5		MHz
$I_S$	Supply Current Per Amplifier			1.6	2.5		1.7	2.8	mA
	Channel Separation	DC to 5kHz, $V_{IN} = \pm 10V$		132			130		dB

**ELECTRICAL CHARACTERISTICS**  $V_S = \pm 15V, V_{CM} = 0V, 0^\circ C \leq T_A \leq 70^\circ C$ , unless otherwise noted.

SYMBOL	PARAMETER	CONDITIONS	LT1057AC LT1058AC			LT1057C LT1058C			UNITS
			MIN	TYP	MAX	MIN	TYP	MAX	
$V_{OS}$	Input Offset Voltage	LT1057	●	250	800		330	1400	$\mu$ V
		LT1058	●	300	1200		400	1800	$\mu$ V
	Average Temperature Coefficient of Input Offset Voltage	LT1057 H/J8 Package	●	1.8	7		2.3	12	$\mu$ V/ $^\circ$ C
		N8 Package	●	3	10		4	16	$\mu$ V/ $^\circ$ C
		LT1058 J Package (Note 4)	●	2.5	10		3	15	$\mu$ V/ $^\circ$ C
		N Package (Note 4)	●	4	15		5	22	$\mu$ V/ $^\circ$ C
$I_{OS}$	Input Offset Current	Warmed Up, $T_A = 70^\circ C$		18	150		20	250	pA
$I_b$	Input Bias Current	Warmed Up, $T_A = 70^\circ C$		$\pm 50$	$\pm 250$		$\pm 60$	$\pm 350$	pA
$A_{VOL}$	Large Signal Voltage Gain	$V_O = \pm 10V, R_L = 2k$	●	70	220		50	200	V/mV
CMRR	Common-Mode Rejection Ratio	$V_{CM} = \pm 10.4V$	●	85	98		80	96	dB
PSRR	Power Supply Rejection Ratio	$V_S = \pm 10V$ to $\pm 18V$	●	87	102		84	100	dB
$V_{OUT}$	Output Voltage Swing	$R_L = 2k$	●	$\pm 12$	$\pm 12.8$		$\pm 12$	$\pm 12.8$	V
$I_S$	Supply Current Per Amplifier	$T_A = 70^\circ C$	●		2.8			3.2	mA
				1.4			1.5		mA

2

**ELECTRICAL CHARACTERISTICS**  $V_S = \pm 15V, V_{CM} = 0V, -55^\circ C \leq T_A \leq 125^\circ C$ , unless otherwise noted.

SYMBOL	PARAMETER	CONDITIONS	LT1057AM LT1058AM			LT1057M LT1058M			UNITS
			MIN	TYP	MAX	MIN	TYP	MAX	
$V_{OS}$	Input Offset Voltage	LT1057	●	300	1100		400	2000	$\mu$ V
		LT1058	●	380	1600		550	2500	$\mu$ V
	Average Temperature Coefficient of Input Offset Voltage	LT1057	●	2.0	7		2.5	12	$\mu$ V/ $^\circ$ C
		LT1058 (Note 4)	●	2.5	10		3	15	$\mu$ V/ $^\circ$ C
$I_{OS}$	Input Offset Current	Warmed Up, $T_A = 125^\circ C$		0.15	2		0.2	3	nA
$I_b$	Input Bias Current	Warmed Up, $T_A = 125^\circ C$		$\pm 0.6$	$\pm 4.5$		$\pm 0.7$	$\pm 6$	nA
$A_{VOL}$	Large Signal Voltage Gain	$V_O = \pm 10V, R_L = 2k$	●	40	120		30	110	V/mV
CMRR	Common-Mode Rejection Ratio	$V_{CM} = \pm 10.4V$	●	84	97		80	95	dB
PSRR	Power Supply Rejection Ratio	$V_S = \pm 10V$ to $\pm 17V$	●	86	100		83	98	dB
$V_{OUT}$	Output Voltage Swing	$R_L = 2k$	●	$\pm 12$	$\pm 12.7$		$\pm 12$	$\pm 12.6$	V
$I_S$	Supply Current Per Amplifier	$T_A = 125^\circ C$		1.25	1.9		1.3	2.2	mA

The ● denotes the specifications which apply over the full operating temperature range.

**Note 1:** Typical parameters are defined as the 60% yield of distributions of individual amplifiers; i.e., out of 100 LT1058s or (100 LT1057s), typically 240 op amps (or 120 for the LT1057) will be better than the indicated specification.

**Note 2:** This parameter is tested on a sample basis only.

**Note 3:** Current noise is calculated from the formula:

$$i_n = (2qI_b)^{1/2}$$

where  $q = 1.6 \times 10^{-19}$  coulomb. The noise of source resistors up to 1G $\Omega$  swamps the contribution of current noise.

**Note 4:** This parameter is not 100% tested.

**Note 5:** Gain-bandwidth product is not tested. It is guaranteed by design and by inference from the slew rate measurement.

# TYPICAL PERFORMANCE CHARACTERISTICS

**Input Bias and Offset Currents vs Temperature**

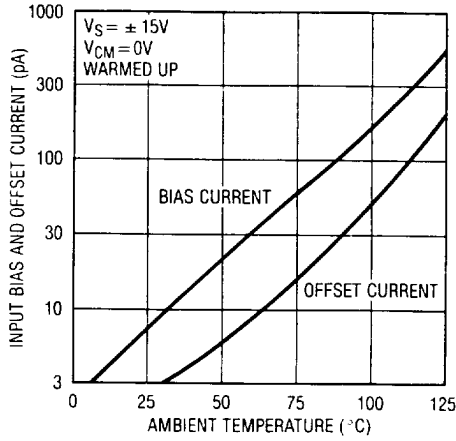

**Input Bias Current Over the Common-Mode Range**

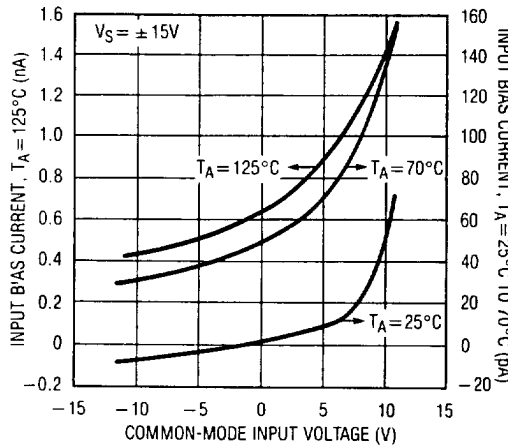

**Warm-Up Drift**

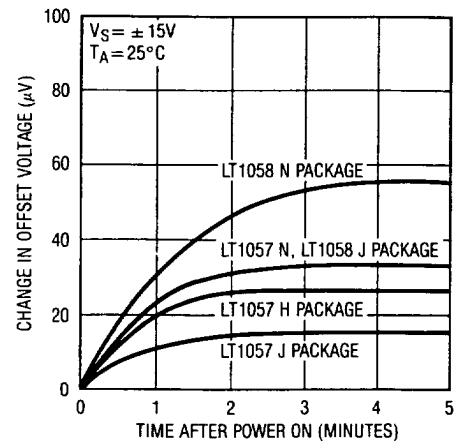

**Distribution of Offset Voltage Drift with Temperature (H and J Package)**

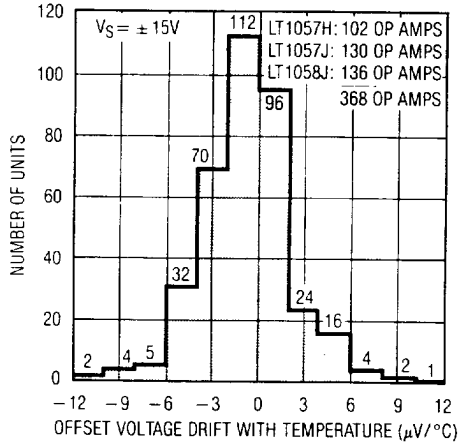

**Distribution of Offset Voltage Drift with Temperature (Plastic N Package)**

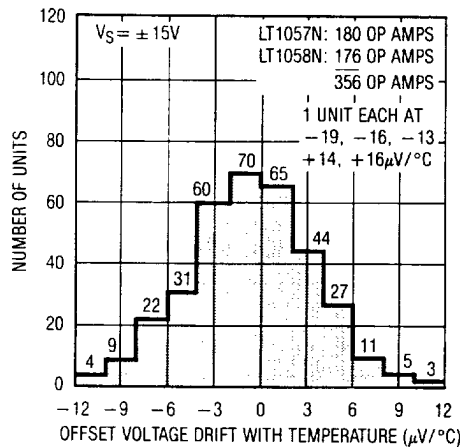

**Long Term Drift of Representative Units**

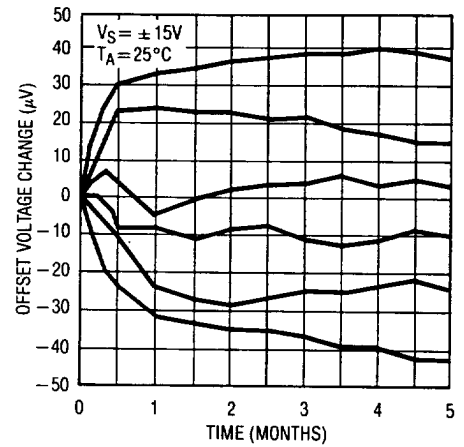

**Voltage Noise vs Frequency**

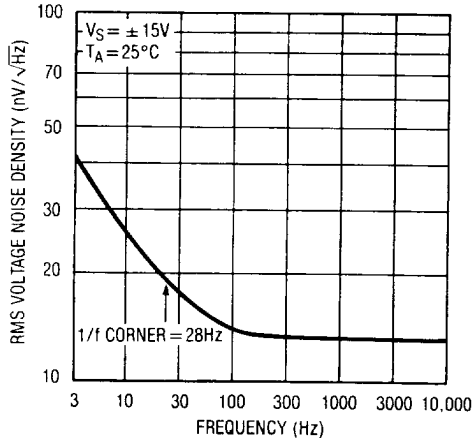

**0.1Hz to 10Hz Noise**

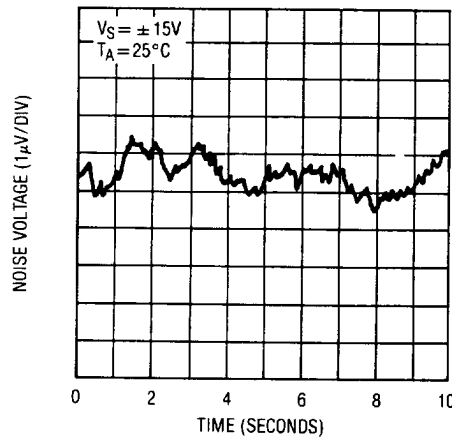

**Voltage Gain vs Temperature**

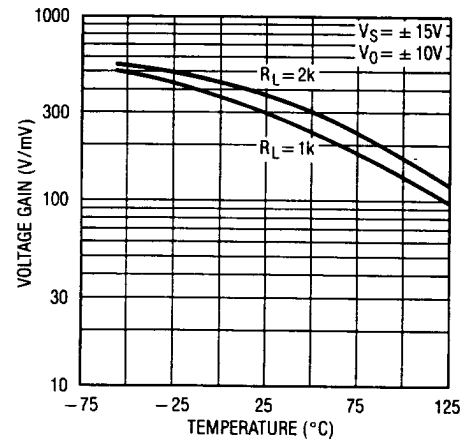

# TYPICAL PERFORMANCE CHARACTERISTICS

Large Signal Response

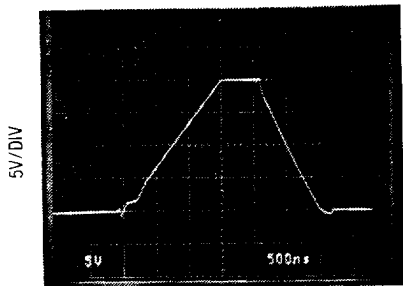

$A_V = +1$ ,  $C_L = 100\text{pF}$ ,  $0.5\mu\text{s}/\text{DIV}$

Slew Rate, Gain-Bandwidth Product vs Temperature

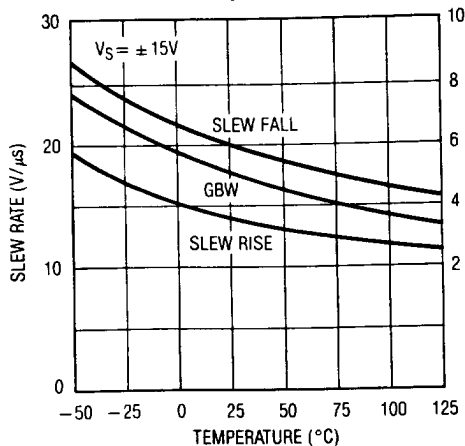

Undistorted Output Swing vs Frequency

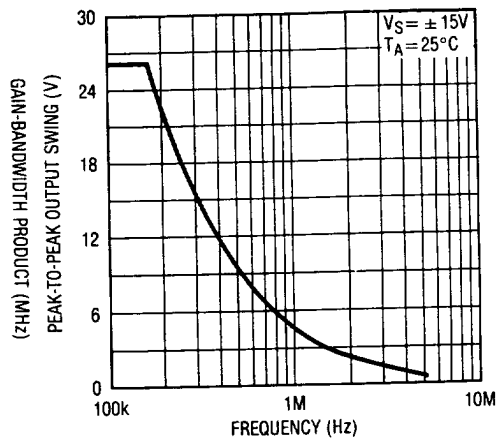

Small Signal Response

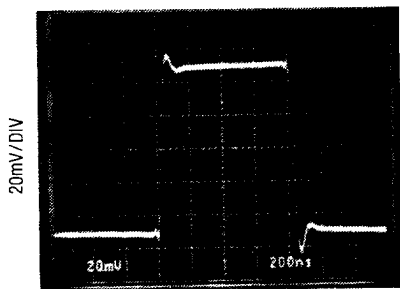

$A_V = +1$ ,  $C_L = 100\text{pF}$ ,  $0.2\mu\text{s}/\text{DIV}$

Gain, Phase Shift vs Frequency

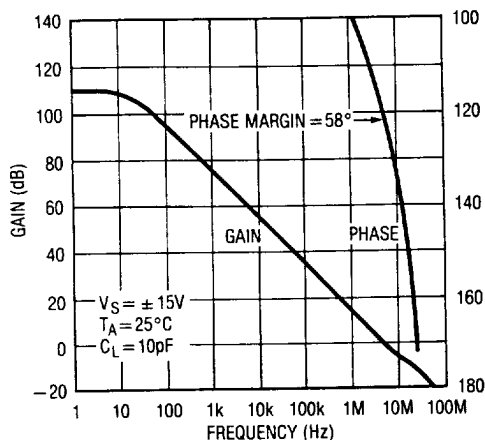

Capacitive Load Handling

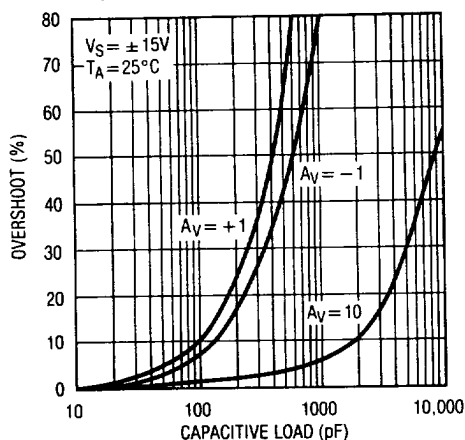

Settling Time

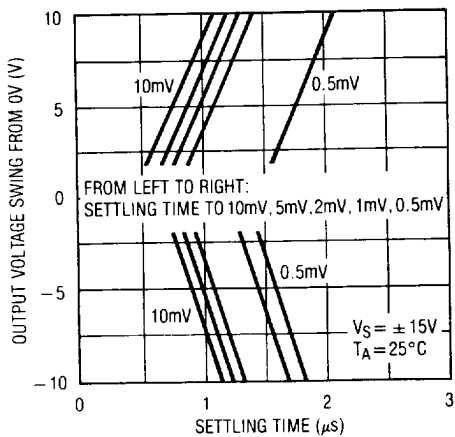

Channel Separation vs Frequency

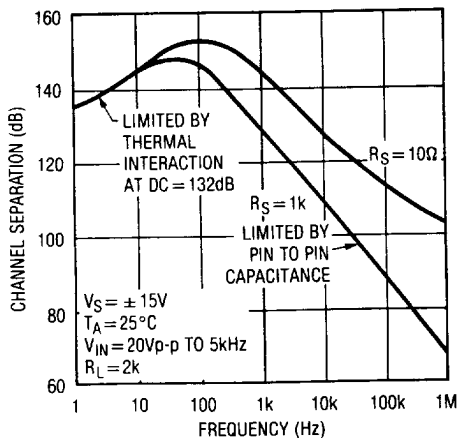

Output Impedance vs Frequency

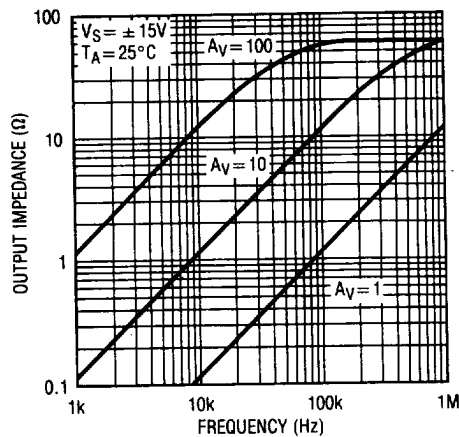

2

# TYPICAL PERFORMANCE CHARACTERISTICS

**Common-Mode Rejection Ratio vs Frequency**

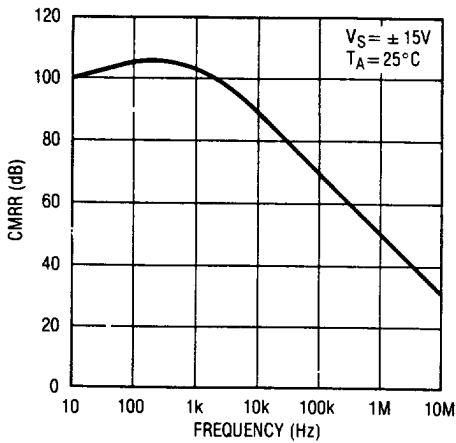

**Common-Mode Range vs Temperature**

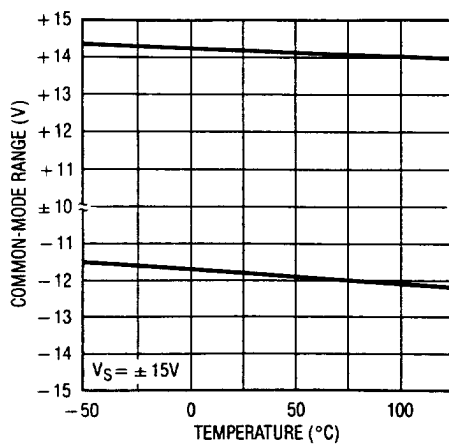

**Common-Mode and Power Supply Rejections vs Temperature**

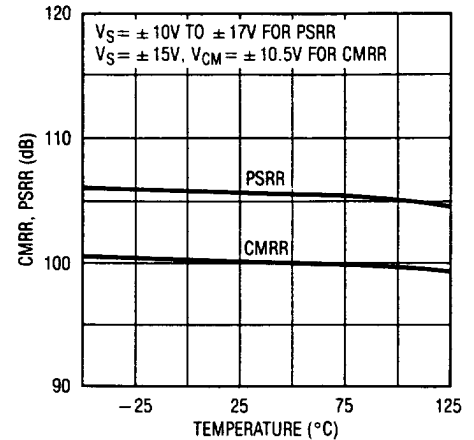

**Power Supply Rejection Ratio vs Frequency**

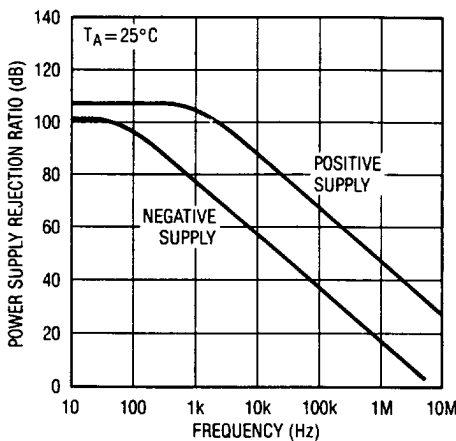

**Supply Current vs Temperature**

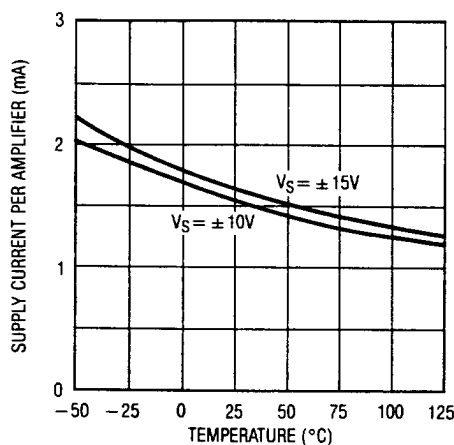

**Short Circuit Current vs Time (One Output Shorted to Ground)**

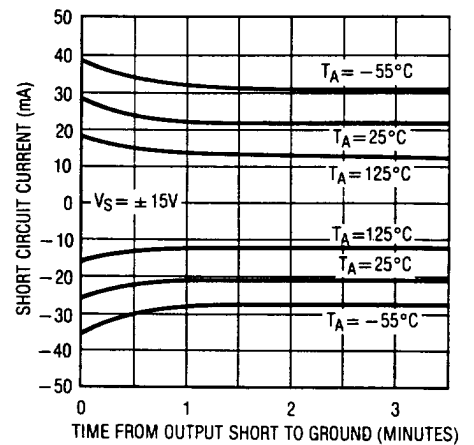

## APPLICATIONS INFORMATION

The LT1057 may be inserted directly into LF353, LF412, LF442, TL072, TL082 and OP-215 sockets. The LT1058 plugs into LF347, LF444, TL074, TL084 sockets. Of course, all standard dual and quad bipolar op amps can also be replaced by these devices.

### High Speed Operation

When the feedback around the op amp is resistive ( $R_F$ ), a pole will be created with  $R_F$ , the source resistance and capacitance ( $R_S, C_S$ ), and the amplifier input capacitance ( $C_{IN} \approx 4\text{pF}$ ). In low closed loop gain configurations and with  $R_S$  and  $R_F$  in the kilohm range, this pole can create excess phase shift and even oscillation. A small capacitor

( $C_F$ ) in parallel with  $R_F$  eliminates this problem. With  $R_S(C_S + C_{IN}) = R_F C_F$ , the effect of the feedback pole is completely removed.

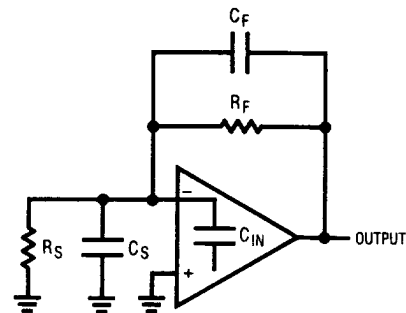

## APPLICATIONS INFORMATION

Settling time is measured in a test circuit which can be found in the LT1055/LT1056 data sheet and in Application Note 10.

### Achieving Picoampere/Microvolt Performance

In order to realize the picoampere/microvolt level accuracy of the LT1057/LT1058, proper care must be exercised. For example, leakage currents in circuitry external to the op amp can significantly degrade performance. High quality insulation should be used (e.g., Teflon™, Kel-F); cleaning of all insulating surfaces to remove fluxes and other residues will probably be required. Surface coating may be necessary to provide a moisture barrier in high humidity environments.

Board leakage can be minimized by encircling the input circuitry with a guard ring operated at a potential close to that of the inputs; in inverting configurations the guard ring should be tied to ground, in non-inverting connections to the inverting input. Guarding both sides of the printed circuit board is required. Bulk leakage reduction depends on the guard ring width.

The LT1057/LT1058 have the lowest offset voltage of any dual and quad JFET input op amps available today. However, the offset voltage and its drift with time and temperature are still not as good as on the best bipolar amplifiers because the transconductance of FETs is considerably lower than that of bipolar transistors. Conversely, this lower transconductance is the main cause of the significantly faster speed performance of FET input op amps.

Teflon™ is a trademark of DuPont.

Offset voltage also changes somewhat with temperature cycling. The AM grades show a typical  $40\mu\text{V}$  hysteresis ( $50\mu\text{V}$  on the M grades) when cycled over the  $-55^\circ\text{C}$  to  $125^\circ\text{C}$  temperature range. Temperature cycling from  $0^\circ\text{C}$  to  $70^\circ\text{C}$  has a negligible (less than  $20\mu\text{V}$ ) hysteresis effect.

The offset voltage and drift performance are also affected by packaging. In the plastic N package the molding compound is in direct contact with the chip, exerting pressure on the surface. While NPN input transistors are largely unaffected by this pressure, JFET device drift is degraded. Consequently, for best drift performance, as shown in the typical performance distribution plots, the J or H packages are recommended.

In applications where speed and picoampere bias currents are not necessary, Linear Technology offers the bipolar input, pin compatible LT1013 and LT1014 dual and quad op amps. These devices have significantly better DC specifications than any JFET input device.

### Phase Reversal Protection

Most industry standard JFET input single, dual and quad op amps (e.g., LF156, LF351, LF353, LF411, LF412, OP-15, OP-16, OP-215, TL084) exhibit phase reversal at the output when the negative common-mode limit at the input is exceeded (i.e., below  $-12\text{V}$  with  $\pm 15\text{V}$  supplies). The photos show a  $\pm 16\text{V}$  sine wave input (A), the response of an LF412A in the unity gain follower mode (B), and the response of the LT1057/LT1058 (C).

The phase reversal of photo (B) can cause lock-up in servo systems. The LT1057/LT1058 does not phase-reverse due to a unique phase reversal protection circuit.

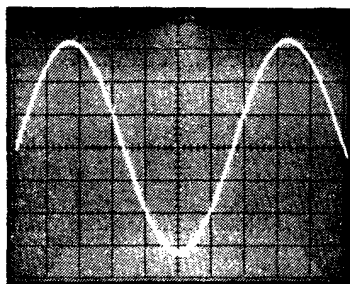

A

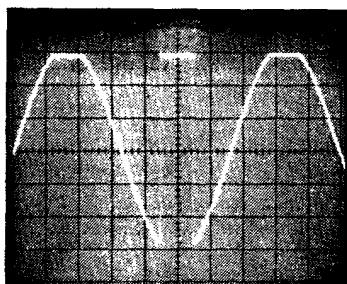
(A)  $\pm 16\text{V}$  Sine Wave Input

B

(B) LF412A Output

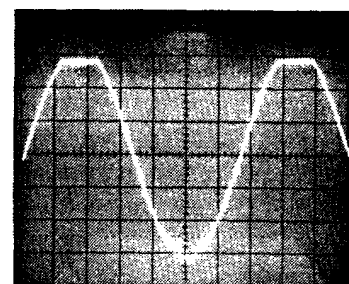

C

(C) LT1057/LT1058 Output

All Photos 5V/Div Vertical Scale, 50 $\mu\text{s}$ /Div Horizontal Scale

**APPLICATIONS**

**Low Noise, Wideband, Gain = 100 Amplifier with High Input Impedance**

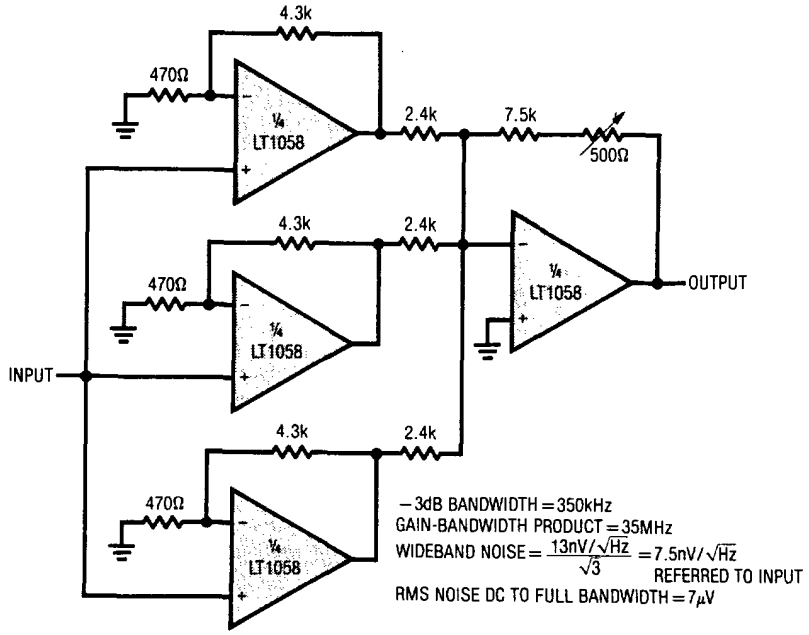

**Wideband, High Input Impedance, Gain = 1000 Amplifier**

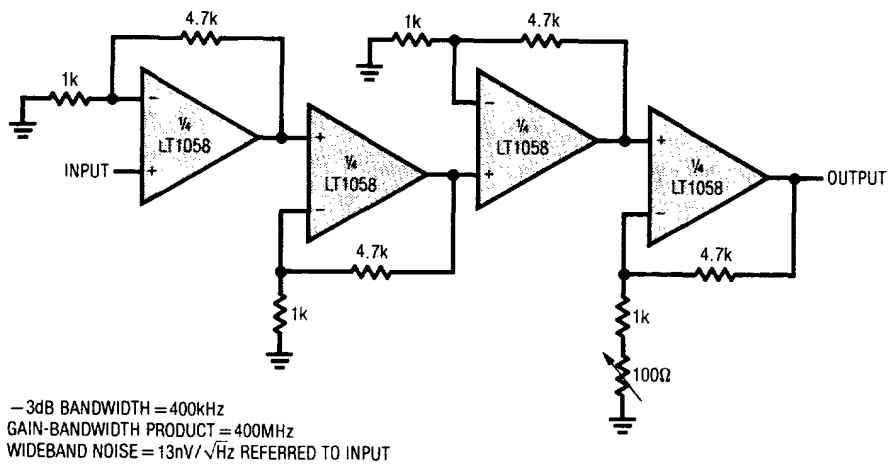

**Low Distortion, Crystal Stabilized Oscillator**

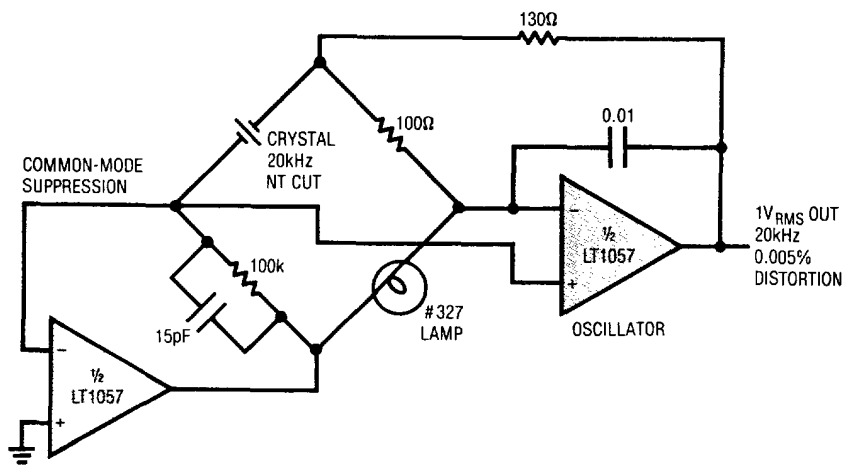



APPLICATIONS

Fast, Precision Bridge Amplifier

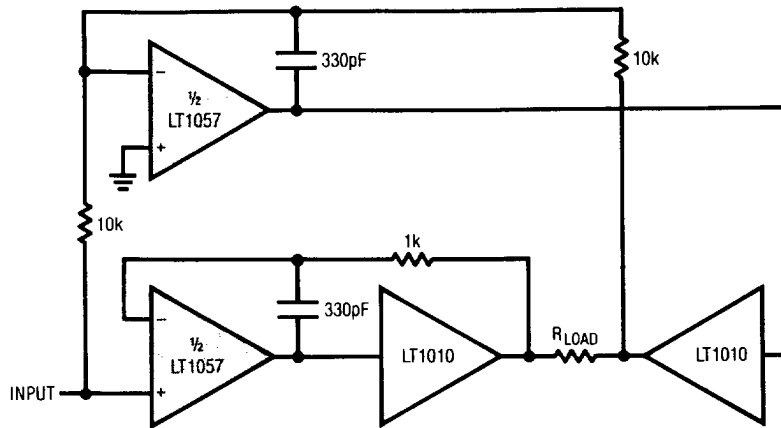

SLEW RATE = 14V/ $\mu$ s  
 OUTPUT CURRENT TO LOAD = 150mA  
 LOAD CAPACITANCE: UP TO 1 $\mu$ F

2

Analog Divider

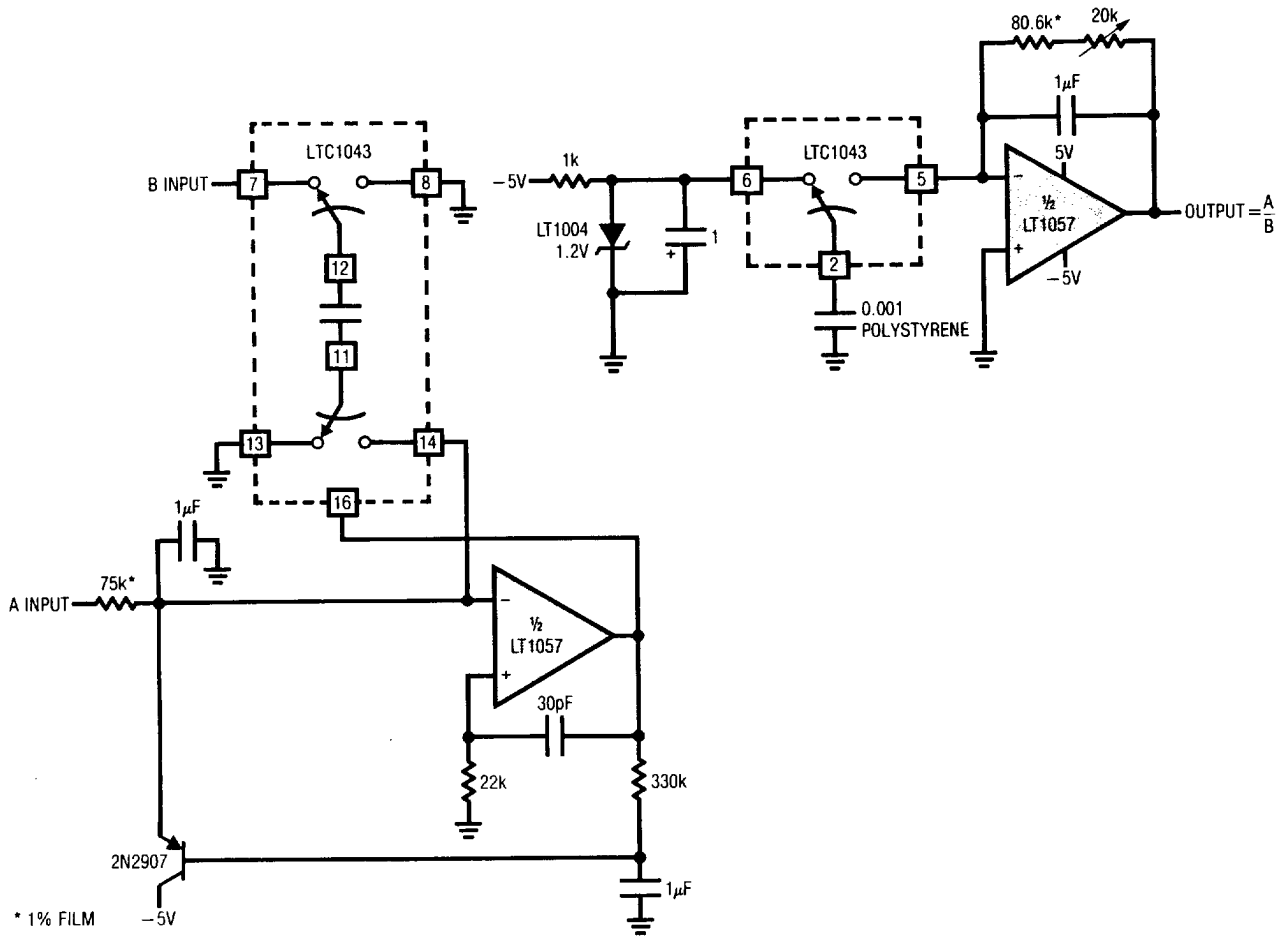

\* 1% FILM

APPLICATIONS

Bipolar Input (AC) V-F Converter

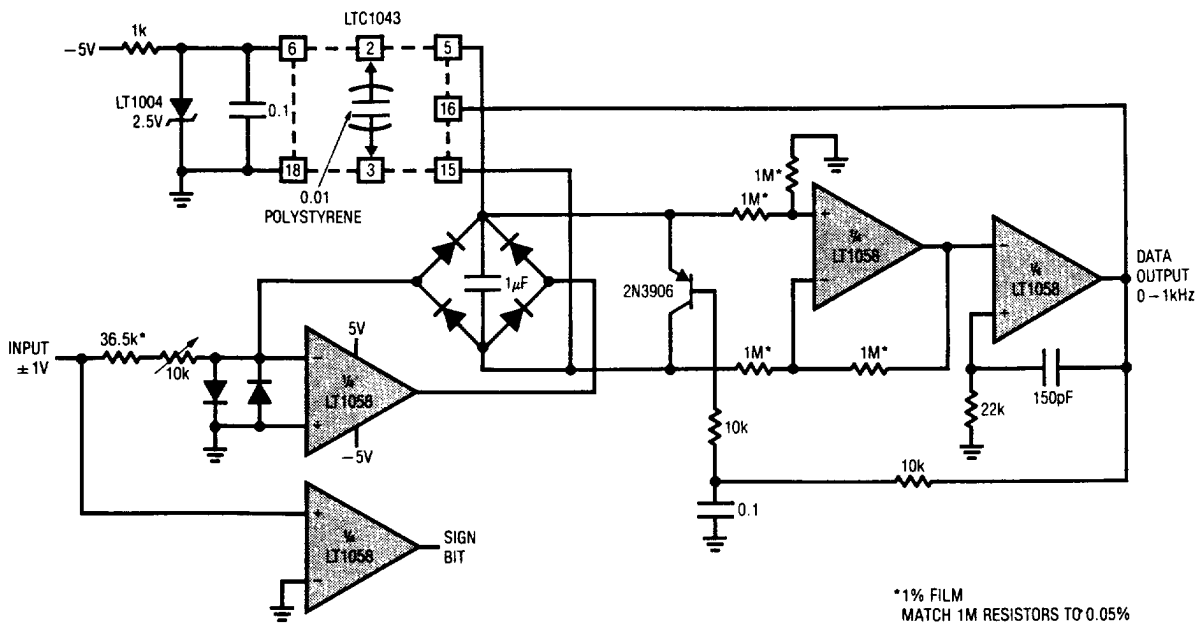

12 Bit A-D Converter

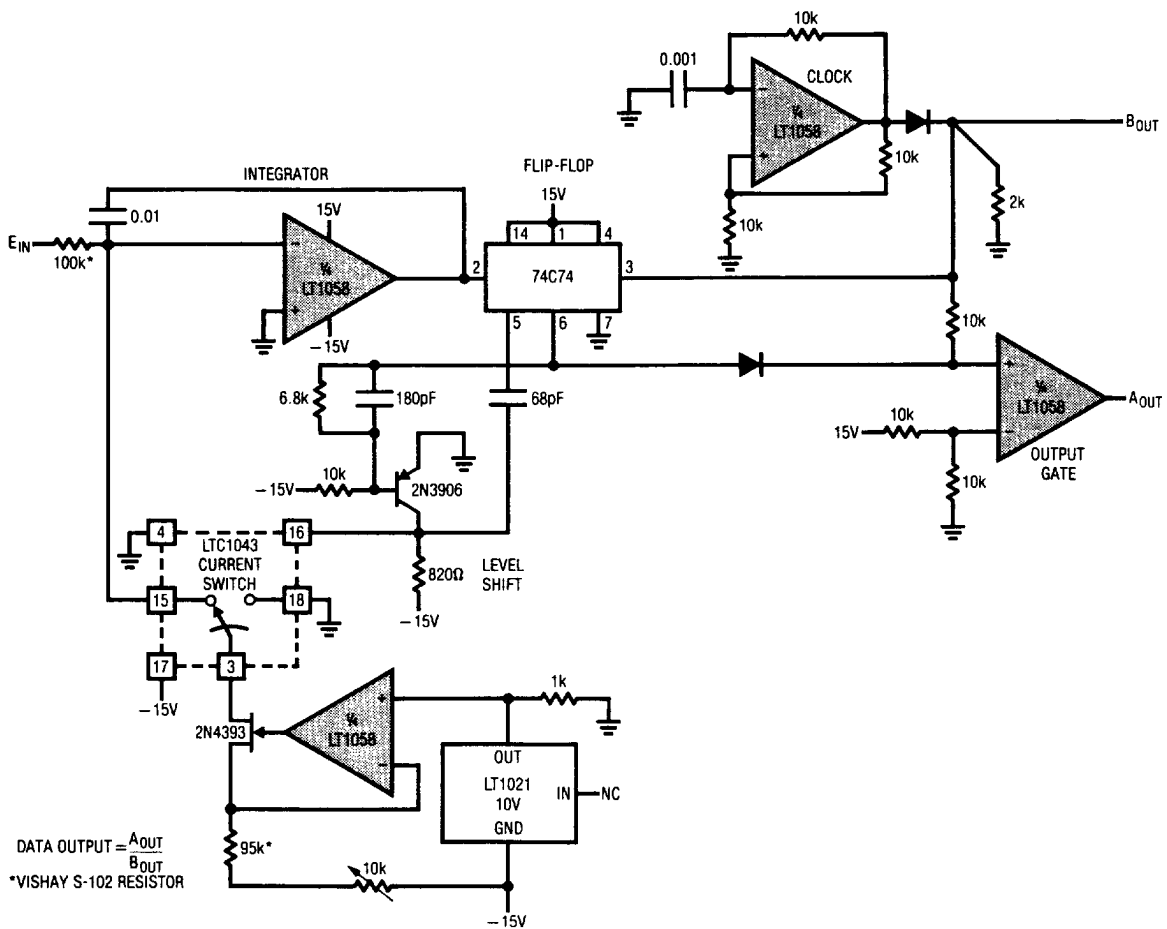

APPLICATIONS

Instrumentation Amplifier with Shield Driver

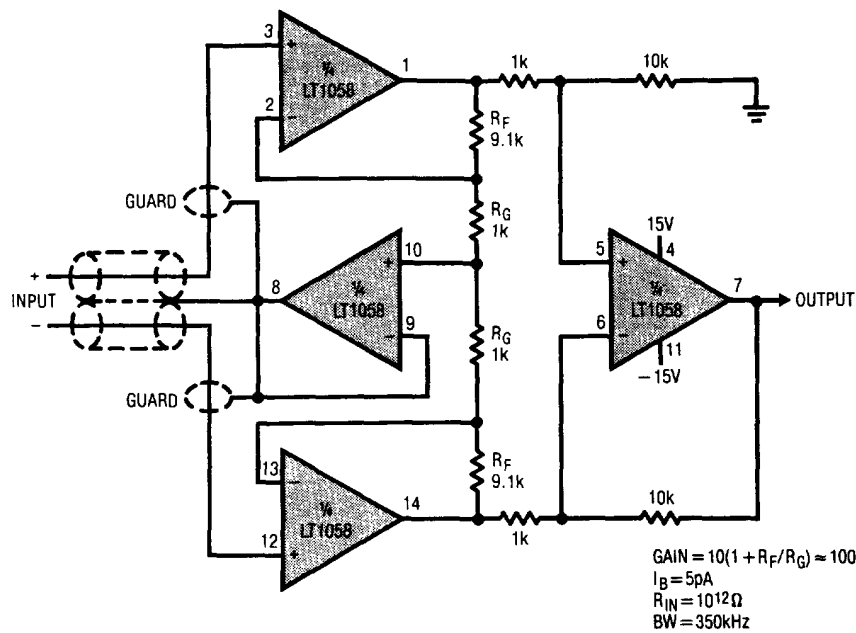

2

100dB Range Logarithmic Photodiode Amplifier

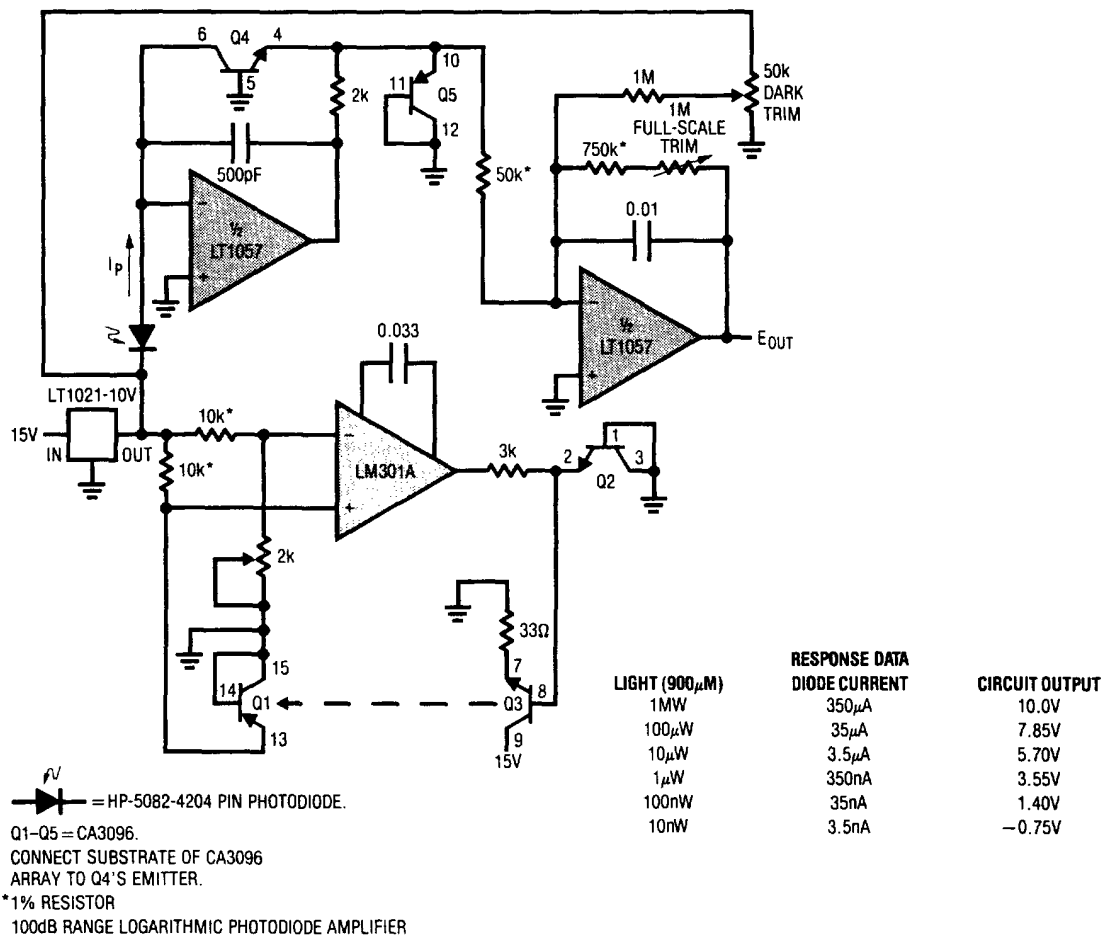

**PACKAGE DESCRIPTION** Dimensions in inches (millimeters) unless otherwise noted.

**H Package  
Metal Can**

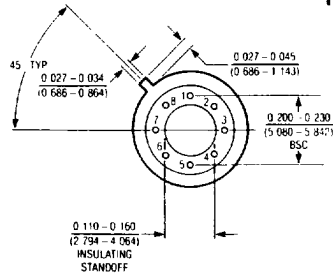

NOTE LEAD DIAMETER IS UNCONTROLLED BETWEEN THE REFERENCE PLANE AND SEATING PLANE

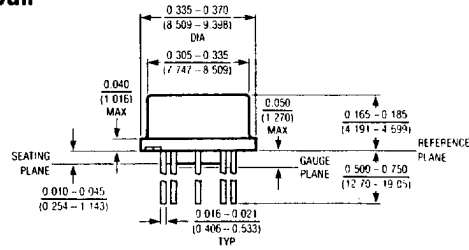

$T_{jmax}$	$\theta_{ja}$	$\theta_{jc}$
150°C	150°C/W	45°C/W

**J8 Package  
8 Lead Hermetic Dip**

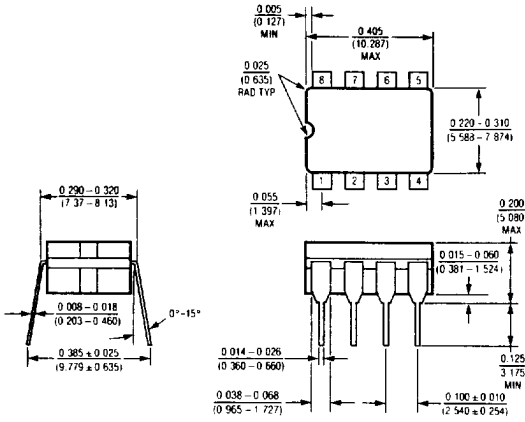

$T_{jmax}$	$\theta_{ja}$
150°C	100°C/W

**N8 Package  
8 Lead Plastic**

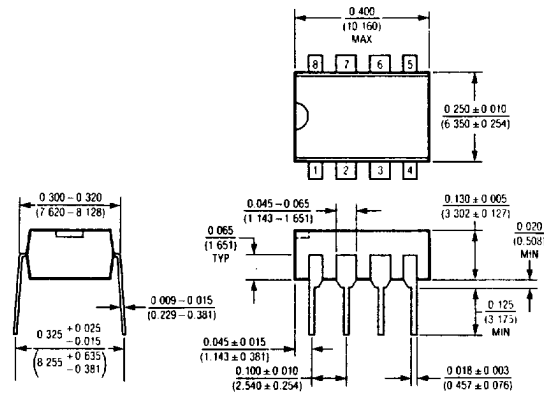

$T_{jmax}$	$\theta_{ja}$
100°C	130°C/W

**J Package  
14-Lead Hermetic DIP**

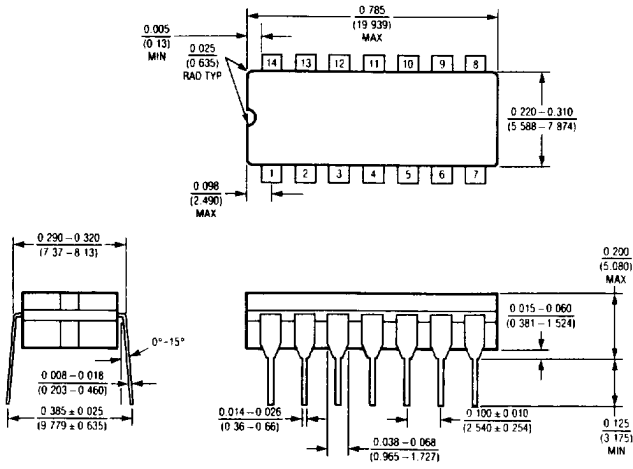

$T_{jmax}$	$\theta_{ja}$
150°C	100°C/W

**N Package  
14-Lead Plastic**

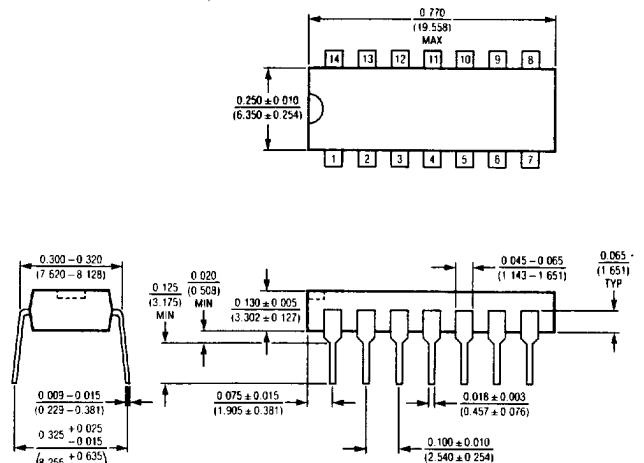

$T_{jmax}$	$\theta_{ja}$
110°C	130°C/W