

98 dB, 96 kHz, Multi-Bit Audio A/D Converter

Features

- ◆ Advanced Multi-Bit $\Delta\Sigma$ Architecture
- ◆ 24-bit Conversion
- ◆ Supports Audio Sample Rates Up to 108 kHz
- ◆ 98 dB Dynamic Range at 5 V
- ◆ -90 dB THD+N
- ◆ Low-Latency Digital Filter
- ◆ High-Pass Filter to Remove DC Offsets
- ◆ Single +3.3 V or +5 V Power Supply
- ◆ Power Consumption Less Than 50 mW
- ◆ Master or Slave Operation
- ◆ Slave Mode Speed Auto-Detect
- ◆ Master Mode Default Settings
- ◆ 256x or 384x MCLK/LRCK Ratio
- ◆ CS5343 Supports I²S Audio Format
- ◆ CS5344 Supports Left-Justified Audio Format

General Description

The CS5343/4 is a complete analog-to-digital converter for digital audio systems. It performs sampling, analog-to-digital conversion, and anti-alias filtering, generating 24-bit values for both left and right inputs in serial form at sample rates up to 108 kHz per channel.

The CS5343/4 uses a 3rd-order, multi-bit Delta-Sigma modulator followed by a digital filter, which removes the need for an external anti-alias filter.

The CS5343/4 also features a high-impedance sampling network which eliminates costly external components such as op-amps.

The CS5343/4 is available in a 10-pin TSSOP package for both Commercial (-10° to +70° C) and Automotive grades (-40° to +85° C). The CDB5343 Customer Demonstration Board is also available for device evaluation and implementation suggestions. Please refer to the "Ordering Information" on page 21 for complete details.

The CS5343/4 is ideal for audio systems requiring wide dynamic range, negligible distortion and low noise, such as set-top boxes, DVD-karaoke players, DVD recorders, A/V receivers, and automotive applications.

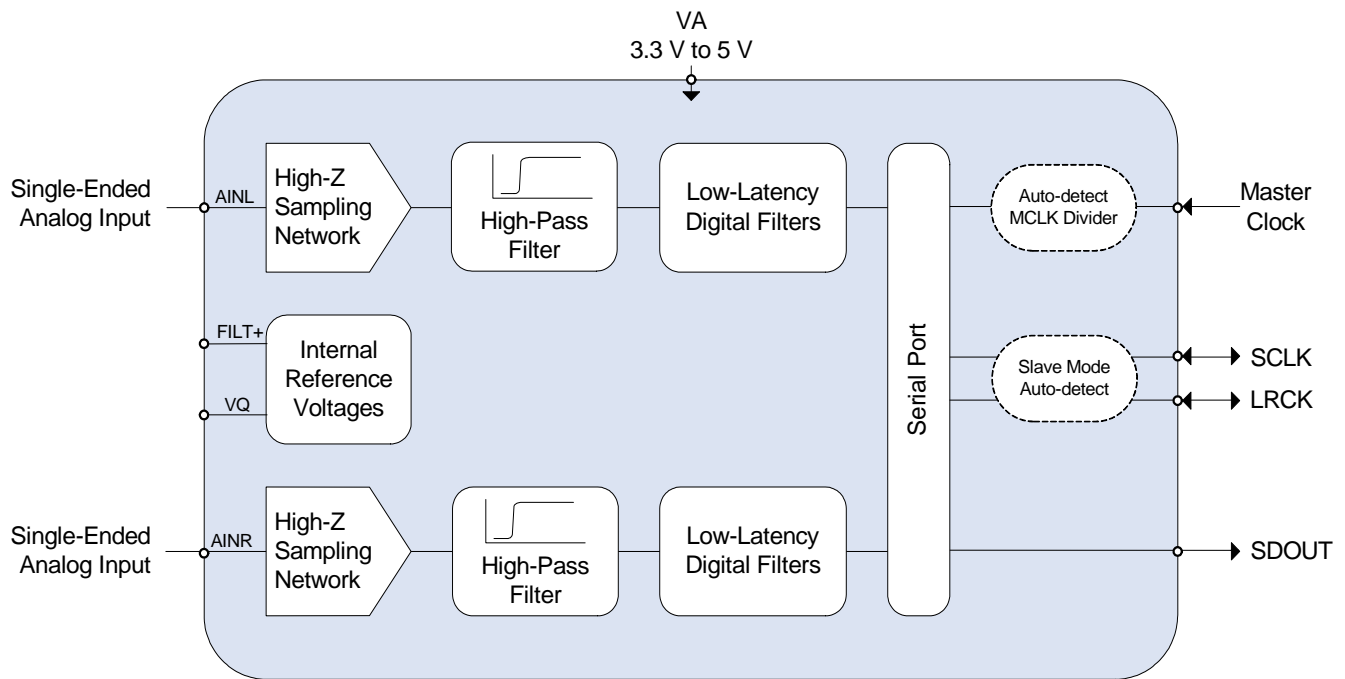

Advance Product Information

This document contains information for a new product. Cirrus Logic reserves the right to modify this product without notice.

TABLE OF CONTENTS

1. PIN DESCRIPTIONS	4
2. CHARACTERISTICS AND SPECIFICATIONS	5
SPECIFIED OPERATING CONDITIONS	5
ABSOLUTE MAXIMUM RATINGS	5
ANALOG CHARACTERISTICS - COMMERCIAL GRADE	6
ANALOG CHARACTERISTICS - AUTOMOTIVE GRADE	7
DIGITAL FILTER CHARACTERISTICS	8
DC ELECTRICAL CHARACTERISTICS	8
DIGITAL CHARACTERISTICS	9
SYSTEM CLOCKING AND SERIAL AUDIO INTERFACE	10
3. TYPICAL CONNECTION DIAGRAM	12
4. APPLICATIONS	13
4.1 Operation as Clock Master or Slave	13
4.1.1 Slave Mode Operation	13
4.1.2 Master Mode Operation	14
4.1.2.1 Master Mode Speed Selection	14
4.1.3 Master Clock	14
4.2 Serial Audio Interface	15
4.3 Digital Interface	15
4.4 Analog Connections	15
4.4.1 Component Values	16
4.5 Grounding and Power Supply Decoupling	16
4.6 Synchronization of Multiple Devices	17
5. FILTER PLOTS	17
6. PARAMETER DEFINITIONS	19
7. PACKAGE DIMENSIONS	20
THERMAL CHARACTERISTICS	20
8. ORDERING INFORMATION	21
9. REVISION HISTORY	21

LIST OF FIGURES

Figure 1. CS5343 I ² S Serial Audio Interface	11
Figure 2. CS5344 Left-Justified Serial Audio Interface	11
Figure 3. Typical Connection Diagram	12
Figure 4. I ² S Serial Audio Interface	15
Figure 5. Left-Justified Serial Audio Interface	15
Figure 6. CS5343/4 Analog Input Network	15
Figure 7. CS5343/4 Example Analog Input Network	16
Figure 8. Single-Speed Mode Stopband Rejection	17
Figure 9. Single-Speed Mode Transition Band	17
Figure 10. Single-Speed Mode Transition Band (Detail)	17
Figure 11. Single-Speed Mode Passband Ripple	17
Figure 12. Double-Speed Mode Stopband Rejection	18
Figure 13. Double-Speed Mode Transition Band	18
Figure 14. Double-Speed Mode Transition Band (Detail)	18
Figure 15. Double-Speed Mode Passband Ripple	18

LIST OF TABLES

Table 1. Master/Slave Mode Selection	13
Table 2. Speed Modes and the Associated Sample Rates (Fs) in Slave Mode.....	13
Table 3. Speed Modes and the Associated Sample Rates (Fs) in Master Mode.....	14
Table 4. Speed Mode Selection in Master Mode	14
Table 5. Common MCLK Frequencies in Master and Slave Modes	14
Table 6. Analog Input Design Parameters	16

1. PIN DESCRIPTIONS

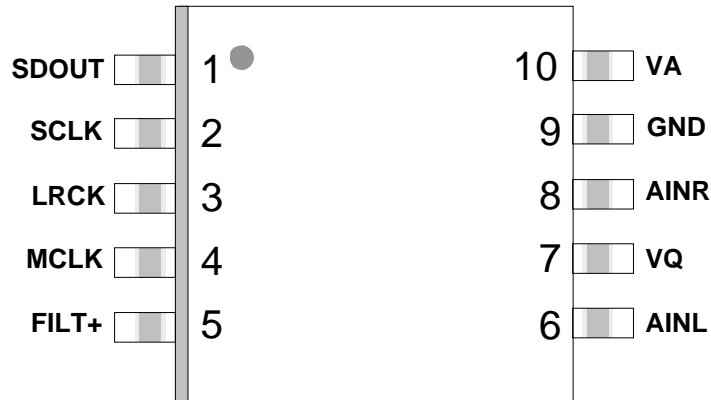

Pin Name	Pin #	Pin Description
SDOUT	1	Serial Audio Data Output (<i>Output</i>) - Output for two's complement serial audio data. Also selects Master or Slave Mode.
SCLK	2	Serial Clock (<i>Input/Output</i>) - Serial clock for the serial audio interface.
LRCK	3	Left Right Clock (<i>Input/Output</i>) - Determines which channel, Left or Right, is currently active on the serial audio data line.
MCLK	4	Master Clock (<i>Input</i>) - Clock source for the delta-sigma modulator and digital filters.
FILT+	5	Positive Voltage Reference (<i>Output</i>) - Positive reference voltage for the internal sampling circuits.
AINL AINR	6 8	Analog Input (<i>Input</i>) - The full-scale analog input level is specified in the Analog Characteristics specification table.
VQ	7	Quiescent Voltage (<i>Output</i>) - Filter connection for the internal quiescent reference voltage.
GND	9	Ground (<i>Input</i>) - Ground reference. Must be connected to analog ground.
VA	10	Power (<i>Input</i>) - Positive power supply for the digital and analog sections.

2. CHARACTERISTICS AND SPECIFICATIONS

(All Min/Max characteristics and specifications are guaranteed over the [Specified Operating Conditions](#). Typical performance characteristics and specifications are derived from measurements taken at typical supply voltages and $T_A = 25^\circ\text{C}$.)

SPECIFIED OPERATING CONDITIONS

(GND = 0 V, all voltages with respect to GND.)

Parameter	Symbol	Min	Typ	Max	Unit	
Power Supplies	VA	3.1	3.3	3.5	V	
		4.75	5.0	5.25	V	
Ambient Operating Temperature	Commercial	T_{AC}	-10	-	70	$^\circ\text{C}$
	Automotive	T_{AD}	-40	-	85	$^\circ\text{C}$

ABSOLUTE MAXIMUM RATINGS

(GND = 0 V, all voltages with respect to GND.) ([Note 1](#))

Parameter	Symbol	Min	Max	Unit
DC Power Supplies	VA	-0.3	+6.0	V
Input Current	I_{in} (Note 2)	-10	+10	mA
Input Voltage	V_{IN} (Note 3)	-0.7	VA+0.7	V
Ambient Operating Temperature (Power Applied)	T_A	-50	+115	$^\circ\text{C}$
Storage Temperature	T_{stg}	-65	+150	$^\circ\text{C}$

Notes:

1. Operation beyond these limits may result in permanent damage to the device. Normal operation is not guaranteed at these extremes.
2. Any pin except supplies. Transient currents of up to ± 100 mA on the analog input pins will not cause SCR latch-up.
3. The maximum over/under voltage is limited by the input current.

ANALOG CHARACTERISTICS - COMMERCIAL GRADE

Test conditions (unless otherwise specified): Input test signal is a 1 kHz sine wave; measurement bandwidth is 10 Hz to 20 kHz; source impedance less than or equal to 2.5 kΩ.

Dynamic Performance for Commercial Grade			VA = 3.3 V			VA = 5.0 V			
Single-Speed Mode	Fs = 48 kHz	Symbol	Min	Typ	Max	Min	Typ	Max	Unit
Dynamic Range	A-weighted		89	95	-	92	98	-	dB
	unweighted		86	92	-	89	95	-	dB
Total Harmonic Distortion + Noise	(Note 4)	THD+N	-	-86	-80	-	-90	-84	dB
	-1 dB		-	-75	-	-	-78	-	dB
	-20 dB		-	-35	-	-	-38	-	dB
	-60 dB		-	-35	-	-	-38	-	dB
Double-Speed Mode	Fs = 96 kHz		Min	Typ	Max	Min	Typ	Max	Unit
Dynamic Range	A-weighted		89	95	-	92	98	-	dB
	unweighted		86	92	-	89	95	-	dB
Total Harmonic Distortion + Noise	(Note 4)	THD+N	-	-86	-80	-	-90	-84	dB
	-1 dB		-	-75	-	-	-78	-	dB
	-20 dB		-	-35	-	-	-38	-	dB
	-60 dB		-	-35	-	-	-38	-	dB
Dynamic Performance for Commercial Grade - All Modes									
			Min	Typ	Max				Unit
Interchannel Isolation			-	90	-				dB
DC Accuracy									
Interchannel Gain Mismatch			-	-	0.1				dB
Gain Error			-3	-	+3				%
Gain Drift			-	±100	-				ppm/°C
Analog Input Characteristics									
Full-scale Input Voltage			0.51*VA	0.56*VA	0.57*VA				Vpp
Input Impedance			-	7.5	-				MΩ

Notes:

4. Referred to the typical full-scale input voltage

ANALOG CHARACTERISTICS - AUTOMOTIVE GRADE

Test conditions (unless otherwise specified): Input test signal is a 1 kHz sine wave; measurement bandwidth is 10 Hz to 20 kHz; source impedance less than or equal to 2.5 k Ω .

Dynamic Performance for Automotive Grade			VA = 3.3 V			VA = 5.0 V			
Single-Speed Mode	Fs = 48 kHz	Symbol	Min	Typ	Max	Min	Typ	Max	Unit
Dynamic Range	A-weighted		87	95	-	90	98	-	dB
	unweighted		84	92	-	87	95	-	dB
Total Harmonic Distortion + Noise	(Note 5)	THD+N	-	-86	-78	-	-90	-82	dB
	-1 dB		-	-75	-	-	-78	-	dB
	-20 dB		-	-35	-	-	-38	-	dB
	-60 dB		-	-35	-	-	-38	-	dB
Double-Speed Mode	Fs = 96 kHz		Min	Typ	Max	Min	Typ	Max	Unit
Dynamic Range	A-weighted		87	95	-	90	98	-	dB
	unweighted		84	92	-	87	95	-	dB
Total Harmonic Distortion + Noise	(Note 5)	THD+N	-	-86	-78	-	-90	-82	dB
	-1 dB		-	-75	-	-	-78	-	dB
	-20 dB		-	-35	-	-	-38	-	dB
	-60 dB		-	-35	-	-	-38	-	dB
Dynamic Performance for Automotive Grade - All Modes									
			Min	Typ	Max				Unit
Interchannel Isolation			-	90	-				dB
DC Accuracy									
Interchannel Gain Mismatch			-	-	0.1				dB
Gain Error			-3	-	+3				%
Gain Drift			-	± 100	-				ppm/ $^{\circ}$ C
Analog Input Characteristics									
Full-scale Input Voltage			0.51*VA	0.56*VA	0.57*VA				Vpp
Input Impedance			-	7.5	-				M Ω

Notes:

5. Referred to the typical full-scale input voltage

DIGITAL FILTER CHARACTERISTICS

Parameter	Symbol	Min	Typ	Max	Unit
Single-Speed Mode $F_s = 4 - 54 \text{ kHz}$					
Passband (-0.1 dB)		0	-	0.489	F _s
Passband Ripple		-0.025	-	0.025	dB
Stopband		0.560	-	-	F _s
Stopband Attenuation		69	-	-	dB
Total Group Delay (F _s = Output Sample Rate)	t _{gd}	-	12/F _s	-	s
Double-Speed Mode $F_s = 86 - 108 \text{ kHz}$					
Passband (-0.1 dB)		0	-	0.489	F _s
Passband Ripple		-0.025	-	0.025	dB
Stopband		0.560	-	-	F _s
Stopband Attenuation		69	-	-	dB
Total Group Delay (F _s = Output Sample Rate)	t _{gd}	-	9/F _s	-	s
High-Pass Filter Characteristics					
Frequency Response	-3.0 dB -0.13 dB	-	1 20	-	Hz Hz
Phase Deviation	@ 20 Hz	-	10	-	Deg
Passband Ripple		-	-	0	dB

Notes:

- Response shown is for F_s equal to 48 kHz. Filter characteristics scale with F_s.

DC ELECTRICAL CHARACTERISTICS

(GND = 0 V, all voltages with respect to 0 V. MCLK=12.288 MHz; Master Mode)

Parameter	Symbol	VA = 3.3 V			VA = 5.0 V			Unit
		Min	Typ	Max	Min	Typ	Max	
DC Power Supplies:	VA	3.1	3.3	-	-	5	5.25	V
Power Supply Current (Normal Operation)	I _A	-	15	-	-	15	-	mA
Power Supply Current (Power-Down Mode) (Note 7)	I _A	-	1.1	-	-	1.1	-	mA
Power Consumption (Normal Operation)	-	-	50	-	-	75	-	mW
Power Consumption (Power-Down Mode) (Note 7)	-	-	3.6	-	-	5.5	-	mW
Parameter	Symbol	Min	Typ	Max	Unit			
Power Supply Rejection Ratio (1 kHz) (Note 8)	PSRR	-	65	-	dB			
V _Q Nominal Voltage		-	0.44xVA	-	V			
Output Impedance		-	25	-	kΩ			
Filt+ Nominal Voltage		-	VA	-	V			
Output Impedance		-	220	-	kΩ			
Maximum allowable DC current source/sink		-	2.5	-	uA			

Notes:

- Device enters power-down mode when MCLK is held static.
- Valid with the recommended capacitor values on Filt+ and V_Q as shown in the Typical Connection Diagram.

DIGITAL CHARACTERISTICS

Parameter	Symbol	Min	Typ	Max	Units
High-Level Input Voltage (% of VA)	V_{IH}	70	-	-	%
Low-Level Input Voltage (% of VA)	V_{IL}	-	-	30	%
High-Level Output Voltage at $I_o = 500 \mu A$ (% of VA)	V_{OH}	70	-	-	%
Low-Level Output Voltage at $I_o = 500 \mu A$ (% of VA)	V_{OL}	-	-	15	%
Input Leakage Current	I_{in}	-10	-	10	μA

SYSTEM CLOCKING AND SERIAL AUDIO INTERFACE

 (Logic "0" = GND = 0 V; Logic "1" = VA, C_L = 20 pF)

Parameter	Symbol	Min	Typ	Max	Unit
Master Mode					
MCLK Period	t _{clkw}	24	-	30	ns
(Double-Speed, 384x Mode)		48	-	60	ns
(Double-Speed, 192x Mode)		36	-	45	ns
(Double-Speed, 256x Mode)		72	-	90	ns
(Double-Speed, 128x Mode)		24	-	325	ns
(Single-Speed, 768x Mode)		48	-	651	ns
(Single-Speed, 384x Mode)		36	-	488	ns
(Single-Speed, 512x Mode)		72	-	976	ns
(Single-Speed, 256x Mode)					
MCLK Duty Cycle		40	50	60	%
Output Sample Rate	F _s	4	-	54	kHz
(Single-Speed)		86	-	108	kHz
(Double-Speed)					
LRCK Duty Cycle		-	50	-	%
SCLK Duty Cycle		-	50	-	%
SDOUT valid before SCLK rising	t _{stp}	10	-	-	ns
SDOUT valid after SCLK rising	t _{hld}	40	-	-	ns
SCLK falling to LRCK edge	t _{slrd}	-20	-	20	ns
Slave Mode					
MCLK Period	t _{clkw}	24	-	30	ns
(Double-Speed, 384x Mode)		48	-	60	ns
(Double-Speed, 192x Mode)		36	-	45	ns
(Double-Speed, 256x Mode)		72	-	90	ns
(Double-Speed, 128x Mode)		24	-	325	ns
(Single-Speed, 768x Mode)		48	-	651	ns
(Single-Speed, 384x Mode)		36	-	488	ns
(Single-Speed, 512x Mode)		72	-	976	ns
(Single-Speed, 256x Mode)					
MCLK Duty Cycle		40	50	60	%
Input Sample Rate	F _s	4	-	54	kHz
(Single-Speed)		86	-	108	kHz
(Double-Speed)					
LRCK Duty Cycle		40	50	60	%
SCLK Period	t _{sclkw}	$\frac{1}{64 \times F_s}$	-	-	ns
SCLK Duty Cycle		45	50	55	%
SDOUT valid before SCLK rising	t _{stp}	10	-	-	ns
SDOUT valid after SCLK rising	t _{hld}	10	-	-	ns
SCLK falling to LRCK edge	t _{slrd}	-20	-	20	ns

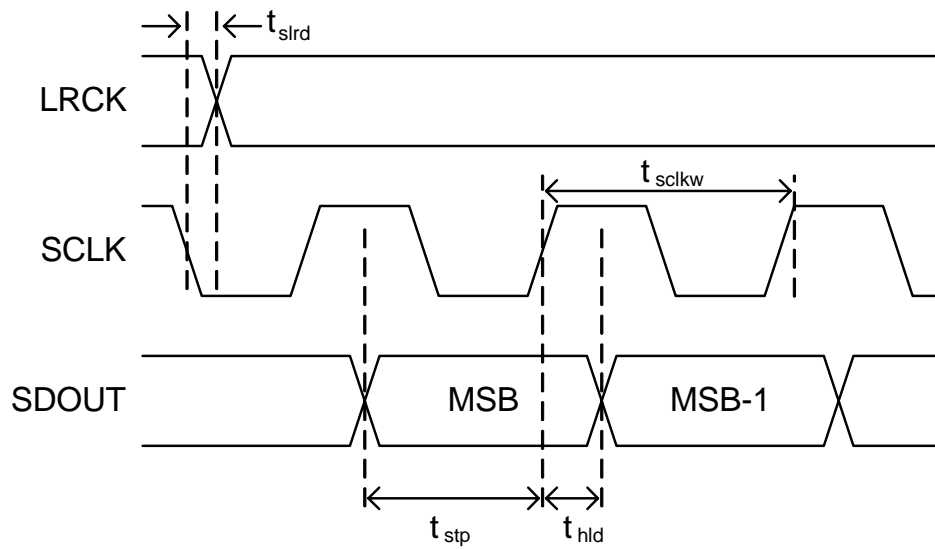

Figure 1. CS5343 I²S Serial Audio Interface

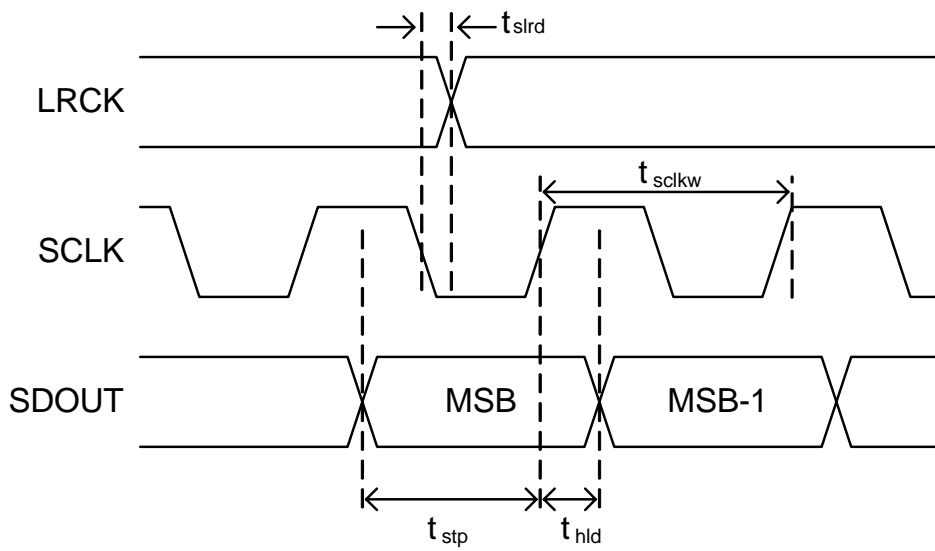
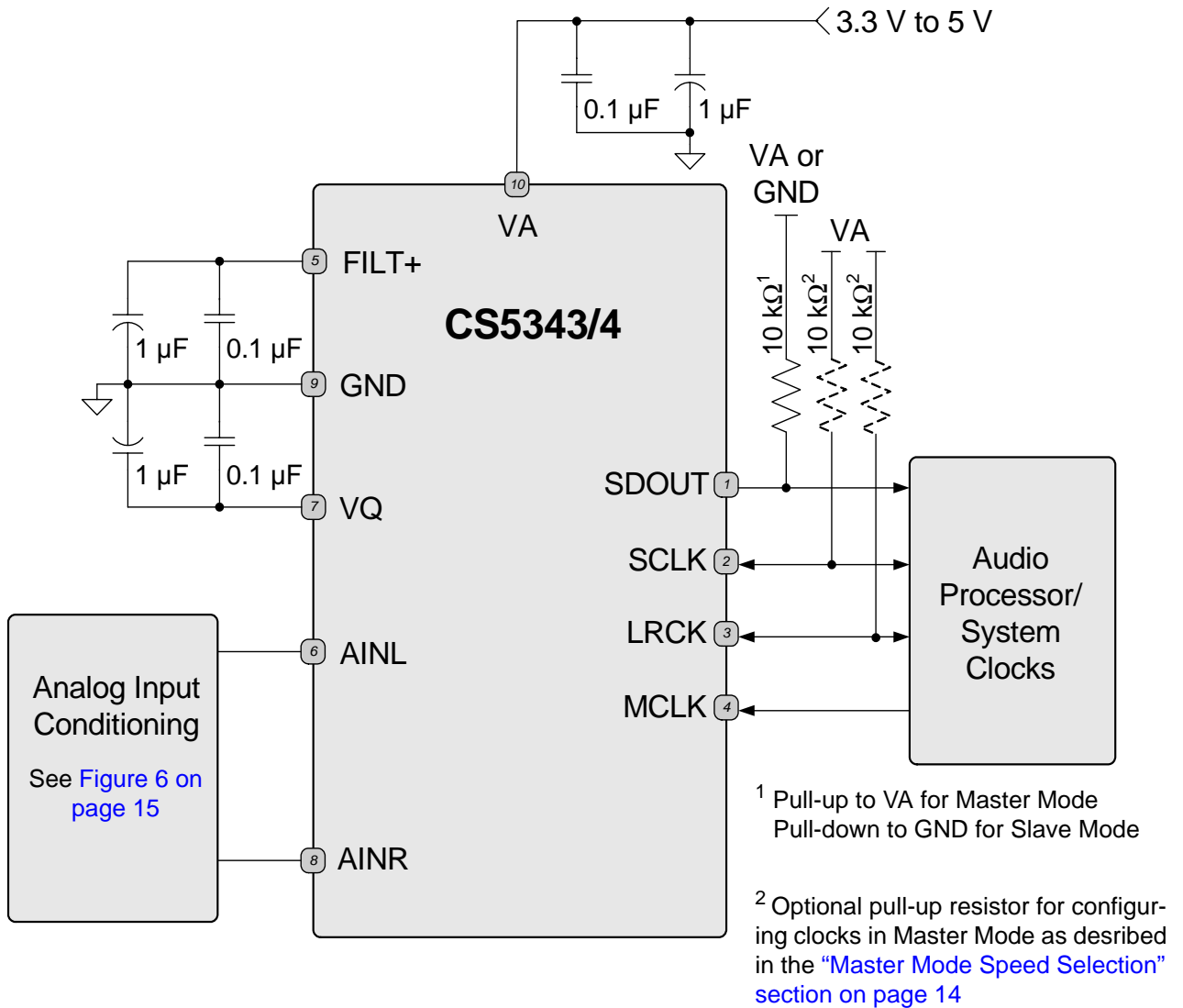

Figure 2. CS5344 Left-Justified Serial Audio Interface

3. TYPICAL CONNECTION DIAGRAM

Figure 3. Typical Connection Diagram

4. APPLICATIONS

4.1 Operation as Clock Master or Slave

The CS5343/4 supports operation as either a clock master or slave. As a clock master, the left/right and serial clocks are synchronously generated on-chip and output on the LRCK and SCLK pins, respectively. As a clock slave, the LRCK and SCLK pins are always inputs and require external generation of the left/right and serial clocks. The selection of clock master or slave is made via a 10 kΩ pull-up resistor from SDOUT to VA for Master Mode selection or via a 10 kΩ pull-down resistor from SDOUT to GND for Slave Mode selection, as shown in [Table 1](#).

Mode	Selection
Master Mode	10 kΩ pull-up resistor from SDOUT to VA
Slave Mode	10 kΩ pull-down resistor from SDOUT to GND

Table 1. Master/Slave Mode Selection

4.1.1 Slave Mode Operation

A unique feature of the CS5343/4 is the automatic selection of either Single- or Double-Speed Mode when acting as a clock slave. The auto-mode selection feature supports all standard audio sample rates from 4 to 108 kHz. Please refer to [Table 2](#) for supported sample rate ranges in Slave Mode.

Speed Mode	MCLK/LRCK Ratio	SCLK/LRCK Ratio	Input Sample Rate Range (kHz)
Single-Speed Mode	256x	64	4 - 54
	512x	64	4 - 54
	384x	48, 64	4 - 54
	768x	48, 64	4 - 54
Double-Speed Mode	128x	64	86 - 108
	256x	64	86 - 108
	192x	48, 64	86 - 108
	384x	48, 64	86 - 108

Table 2. Speed Modes and the Associated Sample Rates (Fs) in Slave Mode

4.1.2 Master Mode Operation

As clock Master, the CS5343/4 generates LRCK and SCLK synchronously on-chip. [Table 3](#) shows the available sample rates and associated clock ratios in Master Mode.

Speed Mode	MCLK/LRCK Ratio	SCLK/LRCK Ratio	Input Sample Rate Range (kHz)
Single-Speed Mode	256x	64	4 - 54
	512x	64	4 - 54
	384x	64	4 - 54
	768x	64	4 - 54
Double-Speed Mode	128x	64	86 - 108
	256x	64	86 - 108
	192x	64	86 - 108
	384x	64	86 - 108

Table 3. Speed Modes and the Associated Sample Rates (Fs) in Master Mode

4.1.2.1 Master Mode Speed Selection

During power-up in Master Mode, the LRCK and SCLK pins are inputs to configure speed mode and the output clock ratio. The LRCK pin is pulled low internally to select Single-Speed Mode by default, but Double-Speed Mode is accessed with a 10 kΩ pull-up resistor from LRCK to VA as shown in [Table 4](#). Similarly, the SCLK pin is internally pulled-low by default to select a 256x MCLK/LRCK ratio, but a MCLK/LRCK ratio of 384x is accessed with a 10 kΩ pull-up resistor from SCLK to VA as shown in [Table 4](#). Following the power-up routine, the LRCK and SCLK pins become clock outputs.

Pin	Resistor Option	Clock Configuration
LRCK	Internal Pull-Down to GND (100 kΩ)	Single-Speed Mode (default)
	External Pull-Up to VA (10 kΩ)	Double-Speed Mode
SCLK	Internal Pull-Down to GND (100 kΩ)	256x MCLK/LRCK (default)
	External Pull-Up to VA (10 kΩ)	384x MCLK/LRCK

Table 4. Speed Mode Selection in Master Mode

4.1.3 Master Clock

The CS5343/4 requires a Master clock (MCLK) which runs the internal sampling circuits and digital filters. There is also an internal MCLK divider which is automatically activated based on the frequency of the MCLK. [Table 4](#) lists some common audio output sample rates and the required MCLK frequency.

Master and Slave Mode					
Sample Rate (kHz)	Speed Mode	MCLK(MHz)		MCLK (MHz)	
		256x	512x	384x	768x
32	SSM	8.912	16.384	12.288	24.576
44.1	SSM	11.289	22.579	16.934	33.868
48	SSM	12.288	24.576	18.432	36.864
Sample Rate (kHz)	Speed Mode	MCLK(MHz)		MCLK (MHz)	
		128x	256x	192x	384x
88.2	DSM	11.289	22.579	16.934	33.868
96	DSM	12.288	24.576	18.432	36.864

Table 5. Common MCLK Frequencies in Master and Slave Modes

4.2 Serial Audio Interface

The CS5343 output is serial data in I²S audio format and the CS5344 output is serial data in Left-Justified audio format. [Figures 4](#) and [5](#) show the I²S and Left-Justified data relative to SCLK and LRCK. Additionally, [Figures 1](#) and [2](#) display more information on the required timing for the serial audio interface format. For an overview of serial audio interface formats, please refer to Cirrus Application Note AN282.

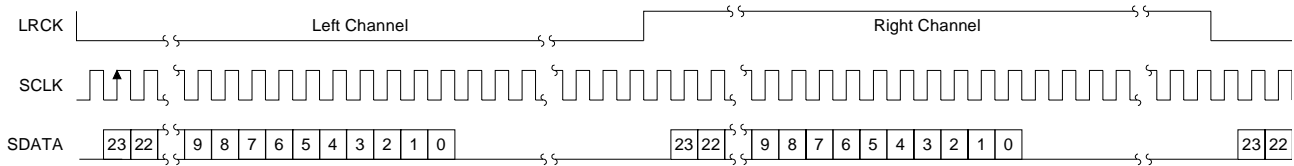

Figure 4. I²S Serial Audio Interface

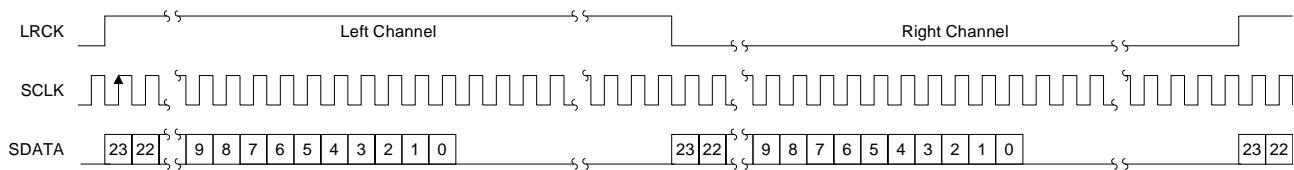

Figure 5. Left-Justified Serial Audio Interface

4.3 Digital Interface

VA supplies power to both the analog and digital sections of the ADC, and also powers the serial port. Consequently, the digital interface logic level must equal VA to within the limits specified under [“Digital Characteristics”](#) on [page 9](#).

4.4 Analog Connections

The analog modulator samples the input signal at half of the internal master clock rate, or 6.144 MHz when MCLK = 12.288 MHz. The digital filter will reject signals within the stopband of the filter. However, there is no rejection for input signals which are multiples of the input sampling frequency ($n \times 6.144$ MHz), where $n=0,1,2,\dots$. Refer to [Figure 6](#) which shows the recommended topology of the analog input network. The external shunt capacitor and internal input impedance form a single-pole RC filter to provide the appropriate filtering of noise at the modulator sampling frequency. Additionally, the 180 pF capacitor acts as a charge source for the internal sampling circuits. Capacitors of NPO or other high-quality dielectric will produce the best results while capacitors with a large voltage coefficient (such as general-purpose ceramics) can degrade signal linearity.

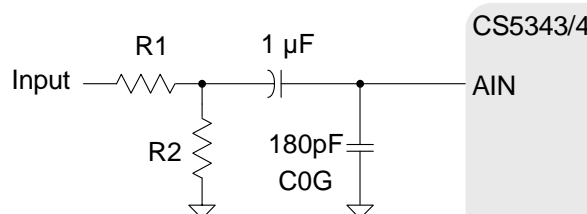

Figure 6. CS5343/4 Analog Input Network

4.4.1 Component Values

Three parameters determine the values of resistors R1 and R2 as shown in [Figure 6](#): source impedance, attenuation, and input impedance. [Table 6](#) shows the design equation used to determine these values.

- **Source Impedance:** Source impedance is defined as the impedance as seen from the ADC looking back into the signal network. The ADC achieves optimal THD+N performance with a source impedance less than or equal to 2.5 kΩ.
- **Attenuation:** The required attenuation factor depends on the magnitude of the input signal. The full-scale input voltage is specified under “[Analog Characteristics - Commercial Grade](#)” on [page 6](#). The user should select values for R1 and R2 such that the magnitude of the incoming signal multiplied by the attenuation factor is less than or equal to the full-scale input voltage of the device.
- **Input Impedance:** Input impedance is the impedance from the signal source to the ADC analog input pins. [Table 6](#) shows the input parameters and the associated design equations.

Source Impedance	$\frac{(R1 \times R2)}{R1 + R2}$
Attenuation Factor	$\frac{(R2)}{(R1 + R2)}$
Input Impedance	$(R1 + R2)$

Table 6. Analog Input Design Parameters

[Figure 7](#) illustrates an example configuration using two 4.99 kΩ resistors in place of R1 and R2. Based on the discussion above, this circuit provides an optimal interface for both the ADC and the signal source. First, consumer equipment frequently requires an input impedance of 10 kΩ, which the 4.99 kΩ resistors provide. Second, this circuit will attenuate a typical line level voltage, 2 V_{rms}, to the full-scale input of the ADC, 1 V_{rms} when V_A = 5 V. Finally, at 2.5 kΩ, the source impedance optimizes analog performance of the ADC.

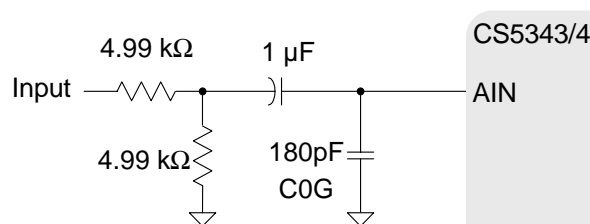

Figure 7. CS5343/4 Example Analog Input Network

4.5 Grounding and Power Supply Decoupling

As with any high-resolution converter, designing with the CS5343/4 requires careful attention to power supply and grounding arrangements if its potential performance is to be realized. [Figure 3](#) shows the recommended power arrangements, with V_A connected to a clean supply. Decoupling capacitors should be as near to the ADC as possible, with the low value ceramic capacitor being the nearest. All signals, especially clocks, should be kept away from the FILT+ and VQ pins in order to avoid unwanted coupling into the modulators. The FILT+ and VQ decoupling capacitors, particularly the 0.01 μF, must be positioned to minimize the electrical path from FILT+ to GND. The CDB5343 evaluation board demonstrates the optimum layout and power supply arrangements. To minimize digital noise, connect the ADC digital outputs only to CMOS inputs.

4.6 Synchronization of Multiple Devices

In systems where multiple ADCs are required, care must be taken to achieve simultaneous sampling. To ensure synchronous sampling, the MCLK, SCLK, and LRCK must be the same for all of the CS5343 and CS5344 devices in the system.

5. FILTER PLOTS

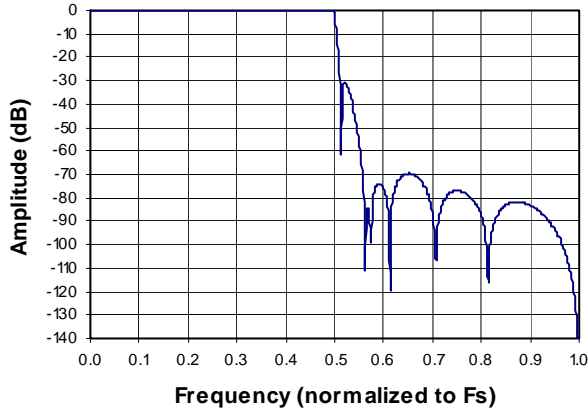

Figure 8. Single-Speed Mode Stopband Rejection

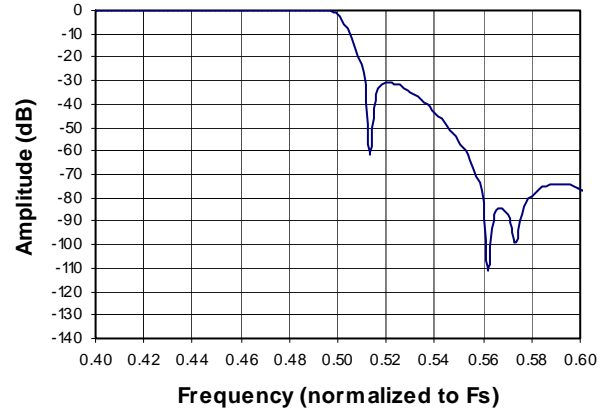

Figure 9. Single-Speed Mode Transition Band

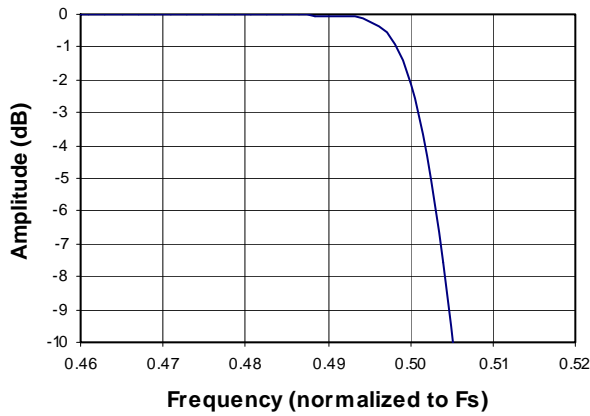

Figure 10. Single-Speed Mode Transition Band (Detail)

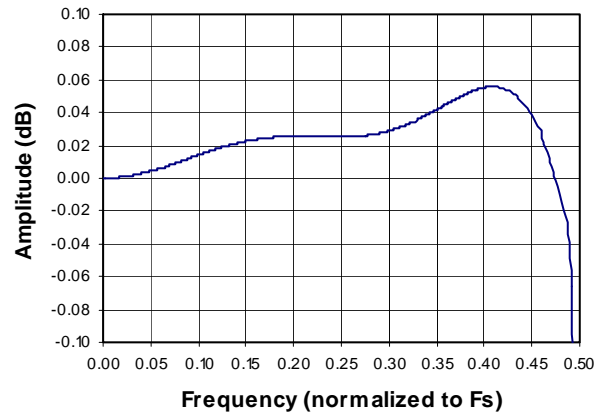
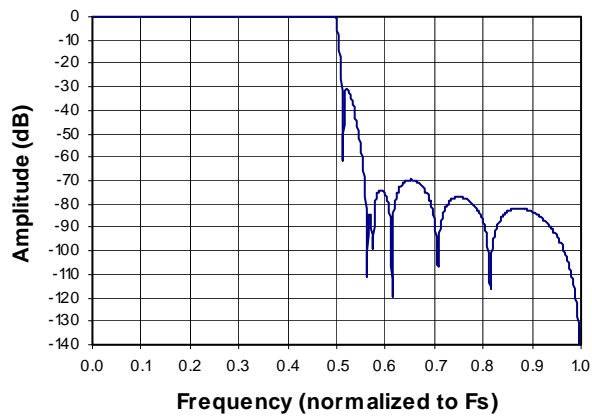
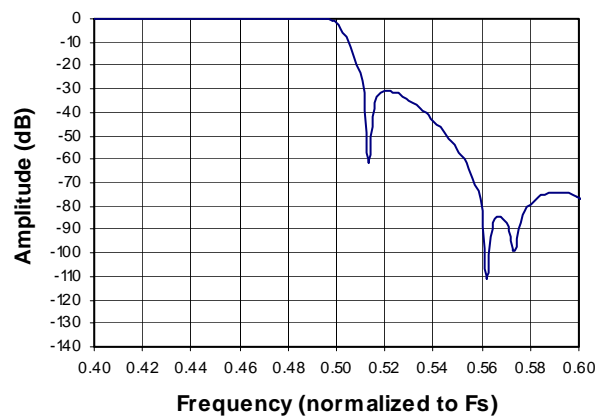
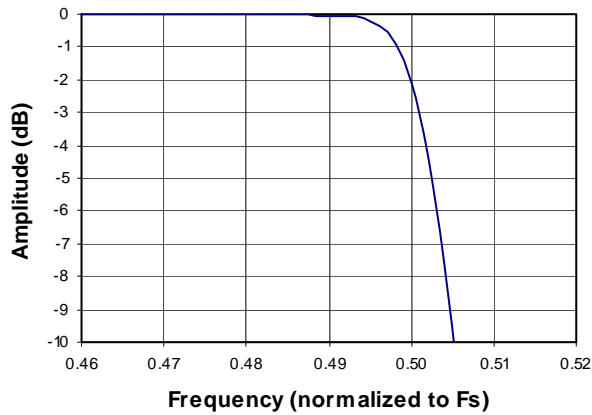
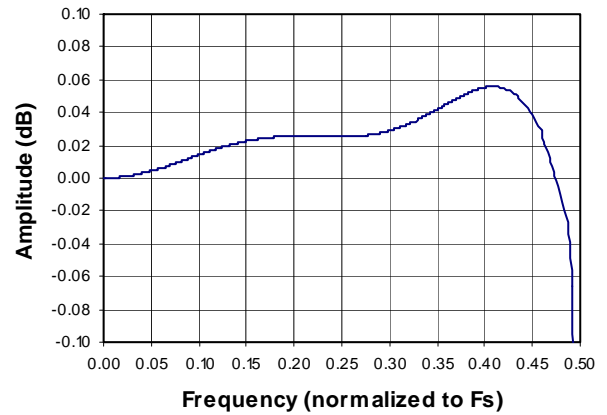

Figure 11. Single-Speed Mode Passband Ripple

Figure 12. Double-Speed Mode Stopband Rejection

Figure 13. Double-Speed Mode Transition Band

Figure 14. Double-Speed Mode Transition Band (Detail)

Figure 15. Double-Speed Mode Passband Ripple

6. PARAMETER DEFINITIONS

Dynamic Range

The ratio of the rms value of the signal to the rms sum of all other spectral components over the specified bandwidth. Dynamic Range is a signal-to-noise ratio measurement over the specified bandwidth made with a -60 dBFS signal. 60 dB is added to resulting measurement to refer the measurement to full-scale. This technique ensures that the distortion components are below the noise level and do not affect the measurement. This measurement technique has been accepted by the Audio Engineering Society, AES17-1991, and the Electronic Industries Association of Japan, EIAJ CP-307. Expressed in decibels.

Total Harmonic Distortion + Noise

The ratio of the rms value of the signal to the rms sum of all other spectral components over the specified bandwidth (typically 10 Hz to 20 kHz), including distortion components. Expressed in decibels. Measured at -1 and -20 dBFS as suggested in AES17-1991 Annex A.

Frequency Response

A measure of the amplitude response variation from 10 Hz to 20 kHz relative to the amplitude response at 1 kHz. Units in decibels.

Interchannel Isolation

A measure of crosstalk between the left and right channels. Measured for each channel at the converter's output with no signal to the input under test and a full-scale signal applied to the other channel. Units in decibels.

Interchannel Gain Mismatch

The gain difference between left and right channels. Units in decibels.

Gain Error

The deviation from the nominal full-scale analog input for a full-scale digital output.

Gain Drift

The change in gain value with temperature. Units in ppm/°C.

Offset Error

The deviation of the mid-scale transition (111...111 to 000...000) from the ideal. Units in mV.

7. PACKAGE DIMENSIONS

10LD TSSOP (3 mm BODY) PACKAGE DRAWING (Note 1)

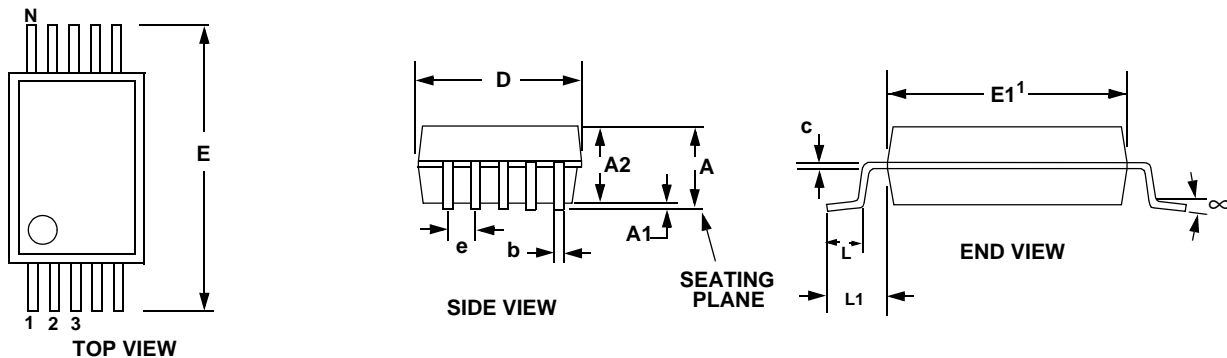

DIM	INCHES			MILLIMETERS			NOTE
	MIN	NOM	MAX	MIN	NOM	MAX	
A	--	--	0.0433	--	--	1.10	
A1	0	--	0.0059	0	--	0.15	
A2	0.0295	--	0.0374	0.75	--	0.95	
b	0.0059	--	0.0118	0.15	--	0.30	4, 5
c	0.0031	--	0.0091	0.08	--	0.23	
D	--	0.1181 BSC	--	--	3.00 BSC	--	2
E	--	0.1929 BSC	--	--	4.90 BSC	--	
E1	--	0.1181 BSC	--	--	3.00 BSC	--	3
e	--	0.0197 BSC	--	--	0.50 BSC	--	
L	0.0157	0.0236	0.0315	0.40	0.60	0.80	
L1	--	0.0374 REF	--	--	0.95 REF	--	
μ	0°	--	8°	0°	--	8°	

Controlling Dimension is Millimeters

Notes:

- Reference document: JEDEC MO-187
- D does not include mold flash or protrusions which is 0.15 mm max. per side.
- E1 does not include inter-lead flash or protrusions which is 0.15 mm max per side.
- Dimension b does not include a total allowable dambar protrusion of 0.08 mm max.
- Exceptions to JEDEC dimension.

THERMAL CHARACTERISTICS

Parameter	Symbol	Min	Typ	Max	Unit
Allowable Junction Temperature	T_J	-	-	135	°C
Junction to Ambient Thermal Impedance	(4-layer PCB) θ_{JA-4}	-	100	-	°C/W
	(2-layer PCB) θ_{JA-2}	-	170	-	°C/W

8. ORDERING INFORMATION

Product	Description	Package	Pb-Free	Grade	Temp Range	Container	Order #
CS5343	98 dB, Multi-Bit Audio A/D Converter, I ² S Audio Format	10-TSSOP	Yes	Commercial	-10° to +70° C	Rail	CS5343-CZZ
						Tape & Reel	CS5343-CZZR
CS5343	98 dB, Multi-Bit Audio A/D Converter, I ² S Audio Format	10-TSSOP	Yes	Automotive	-40° to +85° C	Rail	CS5343-DZZ
						Tape & Reel	CS5343-DZZR
CS5344	98 dB, Multi-Bit Audio A/D Converter, Left-Justified Audio Format	10-TSSOP	Yes	Commercial	-10° to +70° C	Rail	CS5344-CZZ
						Tape & Reel	CS5344-CZZR
CS5344	98 dB, Multi-Bit Audio A/D Converter, Left-Justified Audio Format	10-TSSOP	Yes	Automotive	-40° to +85° C	Rail	CS5344-DZZ
						Tape & Reel	CS5344-DZZR
CDB5343	CS5343 Evaluation Board	-	No	-	-	-	CDB5343

9. REVISION HISTORY

Release	Changes
A2	Changes made to Serial Port diagrams. See Figure 1 and Figure 2 on page 11.
A3	Replaced block diagram on cover page. Increased minimum hold time (Thld) specification on page 10 . Updated Table 4 , "Speed Mode Selection in Master Mode," on page 14 .
A4	Corrected MCLK timing specifications on page 10 Corrected "Typical Connection Diagram" on page 12 Corrected Table 3 , "Speed Modes and the Associated Sample Rates (Fs) in Master Mode," on page 14

Contacting Cirrus Logic Support

For all product questions and inquiries, contact a Cirrus Logic Sales Representative.
To find one nearest you, go to www.cirrus.com.

IMPORTANT NOTICE

"Advance" product information describes products that are in development and subject to development changes. Cirrus Logic, Inc. and its subsidiaries ("Cirrus") believe that the information contained in this document is accurate and reliable. However, the information is subject to change without notice and is provided "AS IS" without warranty of any kind (express or implied). Customers are advised to obtain the latest version of relevant information to verify, before placing orders, that information being relied on is current and complete. All products are sold subject to the terms and conditions of sale supplied at the time of order acknowledgment, including those pertaining to warranty, indemnification, and limitation of liability. No responsibility is assumed by Cirrus for the use of this information, including use of this information as the basis for manufacture or sale of any items, or for infringement of patents or other rights of third parties. This document is the property of Cirrus and by furnishing this information, Cirrus grants no license, express or implied under any patents, mask work rights, copyrights, trademarks, trade secrets or other intellectual property rights. Cirrus owns the copyrights associated with the information contained herein and gives consent for copies to be made of the information only for use within your organization with respect to Cirrus integrated circuits or other products of Cirrus. This consent does not extend to other copying such as copying for general distribution, advertising or promotional purposes, or for creating any work for resale.

CERTAIN APPLICATIONS USING SEMICONDUCTOR PRODUCTS MAY INVOLVE POTENTIAL RISKS OF DEATH, PERSONAL INJURY, OR SEVERE PROPERTY OR ENVIRONMENTAL DAMAGE ("CRITICAL APPLICATIONS"). CIRRUS PRODUCTS ARE NOT DESIGNED, AUTHORIZED OR WARRANTED FOR USE IN AIRCRAFT SYSTEMS, MILITARY APPLICATIONS, PRODUCTS SURGICALLY IMPLANTED INTO THE BODY, AUTOMOTIVE SAFETY OR SECURITY DEVICES, LIFE SUPPORT PRODUCTS OR OTHER CRITICAL APPLICATIONS. INCLUSION OF CIRRUS PRODUCTS IN SUCH APPLICATIONS IS UNDERSTOOD TO BE FULLY AT THE CUSTOMER'S RISK AND CIRRUS DISCLAIMS AND MAKES NO WARRANTY, EXPRESS, STATUTORY OR IMPLIED, INCLUDING THE IMPLIED WARRANTIES OF MERCHANTABILITY AND FITNESS FOR PARTICULAR PURPOSE, WITH REGARD TO ANY CIRRUS PRODUCT THAT IS USED IN SUCH A MANNER. IF THE CUSTOMER OR CUSTOMER'S CUSTOMER USES OR PERMITS THE USE OF CIRRUS PRODUCTS IN CRITICAL APPLICATIONS, CUSTOMER AGREES, BY SUCH USE, TO FULLY INDEMNIFY CIRRUS, ITS OFFICERS, DIRECTORS, EMPLOYEES, DISTRIBUTORS AND OTHER AGENTS FROM ANY AND ALL LIABILITY, INCLUDING ATTORNEYS' FEES AND COSTS, THAT MAY RESULT FROM OR ARISE IN CONNECTION WITH THESE USES.

Cirrus Logic, Cirrus, and the Cirrus Logic logo designs are trademarks of Cirrus Logic, Inc. All other brand and product names in this document may be trademarks or service marks of their respective owners.