

Self-Calibrating TPOS Speed Sensor Optimized for Automotive Cam Sensing Applications

Features and Benefits

- Chopper stabilized; optimized for automotive cam sensing applications
- Optimized absolute timing accuracy step size through gradual transition from TPOS to Running Mode
- High immunity to signal anomalies resulting from magnetic overshoot and peak-to-peak field variation
- Tight timing accuracy over full operating temperature range
- True zero-speed operation
- Automatic Gain Control circuitry for air gap independent switchpoints
- Operation at supply voltages down to 3.3 V
- Digital output representing target profile
- Undervoltage lockout (UVLO)
- Patented Hall IC-magnet system
- Increased output fall time for improved radiated emissions performance

Package: 4-pin SIP module (suffix SE)

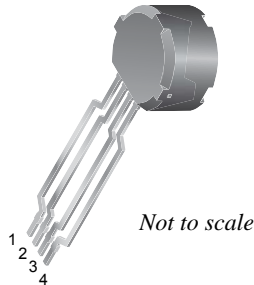

Description

The ATS675 is the next generation of the Allegro® True Power-On State (TPOS) sensor family, offering improved accuracy compared to prior generations, gradual TPOS to Running Mode adjustment for accuracy-shift reduction, and longer output fall time for improved radiated emissions performance. The ATS675 provides absolute zero-speed performance and TPOS information.

The sensor incorporates a single-element Hall IC with an optimized custom magnetic circuit that switches in response to magnetic signals created by a ferromagnetic target. The IC contains a sophisticated digital circuit designed to eliminate the detrimental effects of magnet and system offsets. Signal processing is used to provide device performance at zero target speed, independent of air gap, and which adapts dynamically to the typical operating conditions found in automotive applications, particularly camshaft-sensing applications.

High resolution peak-detecting DACs are used to set the adaptive switching thresholds of the device, ensuring high accuracy despite target eccentricity. Internal hysteresis in the thresholds reduces the negative effects of anomalies in the magnetic signal (such as magnetic overshoot) associated with targets used in many automotive applications. The resulting output of the device is a digital representation of the ferromagnetic target profile. The ATS675 also includes a low bandwidth filter that increases the noise immunity and the signal-to-noise ratio of the sensor.

The device package is lead (Pb) free, with 100% matte tin leadframe plating.

Typical Application

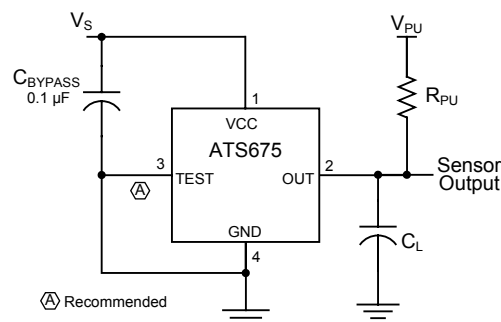

Figure 1. Operational circuit for the ATS675

ATS675LSE

Self-Calibrating TPOS Speed Sensor Optimized for Automotive Cam Sensing Applications

Selection Guide

Part Number	Output Protocol	Packing*
ATS675LSETN-LT-T	Output low opposite target tooth	13-in. reel, 450 pieces per reel
ATS675LSETN-HT-T	Output high opposite target tooth	



*Contact Allegro for additional packing options

Absolute Maximum Ratings

Characteristic	Symbol	Notes	Rating	Units
Supply Voltage	V_{CC}		28	V
Reverse Supply Voltage	V_{RCC}		-18	V
Reverse Supply Current	I_{RCC}		-50	mA
Output Current	$I_{OUT(sink)}$	Internal current limiting is intended to protect the device from output short circuits, but is not intended for continuous operation.	20	mA
Operating Ambient Temperature	T_A	Range L	-40 to 150	°C
Maximum Junction Temperature	$T_J(max)$		165	°C
Storage Temperature	T_{stg}		-65 to 170	°C

Thermal Characteristics may require derating at maximum conditions, see application information

Characteristic	Symbol	Test Conditions*	Value	Units
Package Thermal Resistance	$R_{\theta JA}$	1-layer PCB with copper limited to solder pads	101	°C/W
		2-layer PCB with copper limited to solder pads and 3.57 in. ² of copper area each side	77	°C/W

*Additional thermal information available on the Allegro website

Power Derating Curve

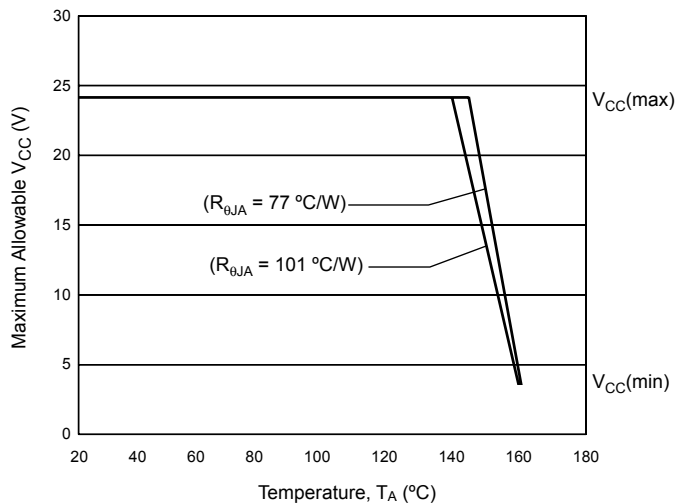

Power Dissipation versus Ambient Temperature

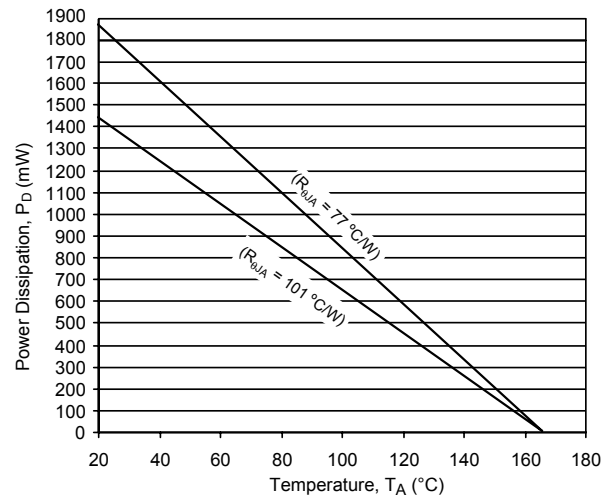

Allegro MicroSystems, Inc.
115 Northeast Cutoff
Worcester, Massachusetts 01615-0036 U.S.A.
1.508.853.5000; www.allegromicro.com

Functional Block Diagram

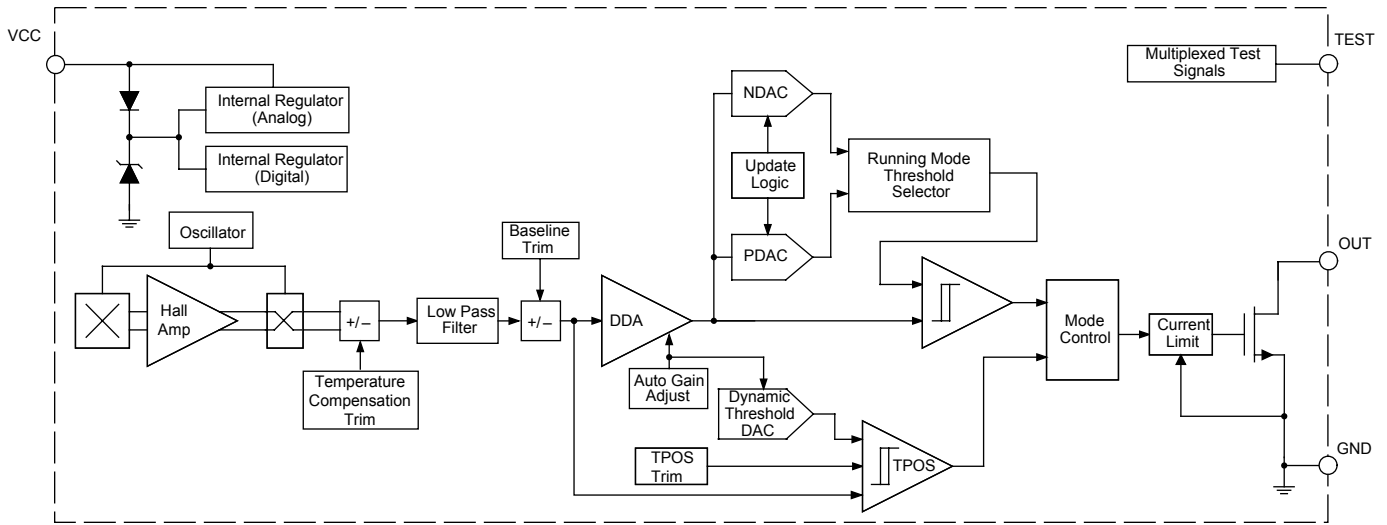

Pin-out Diagram

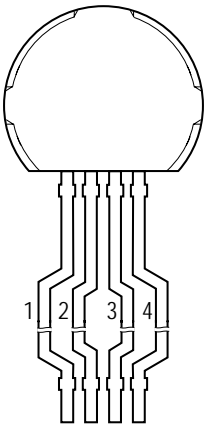

Terminal List

Number	Name	Function
1	VCC	Supply voltage
2	OUT	Open drain output
3	TEST	Test pin; connection to GND recommended
4	GND	Ground

OPERATING CHARACTERISTICS Valid using reference target 8X, T_A, T_J , and V_{CC} within specification, unless otherwise noted							
Characteristics	Symbol	Test Conditions	Min.	Typ. ¹	Max.	Unit	
Electrical Characteristics							
Supply Voltage ²	V_{CC}	Operating, $T_J < T_{J(max)}$	3.3	–	24	V	
Undervoltage Lockout	V_{CCUV}	$V_{CC} = 0 \rightarrow 5\text{ V}$ or $5 \rightarrow 0\text{ V}$	–	–	3.3	V	
Supply Zener Clamp Voltage	$V_{Zsupply}$	$I_{CC} = I_{CC(max)} + 3\text{ mA}$, $T_A = 25^\circ\text{C}$	28	33	40	V	
Supply Zener Current ³	$I_{Zsupply}$	$V_S = 28\text{ V}$	–	–	13	mA	
Supply Current	I_{CC}		–	6.5	10	mA	
Reverse Battery Current ⁴	I_{RCC}	$V_{RCC} = -18\text{ V}$	–	-5	-10	mA	
Chopping Frequency	f_c		–	500	–	kHz	
Power-On Characteristics							
Power-On Time ⁵	t_{PO}	$V_{CC} > V_{CC(min)}$, $f_{SIG} < 200\text{ Hz}$	–	–	1	ms	
Output Stage Characteristics							
Output On Voltage	$V_{OUT(SAT)}$	$I_{OUT} = 10\text{ mA}$, output in on-state	–	–	400	mV	
		$I_{OUT} = 15\text{ mA}$, output in on-state	–	–	450	mV	
Output Zener Voltage	V_{ZOUT}	$I_{OUT} = 3\text{ mA}$, $T_A = 25^\circ\text{C}$	30	–	–	V	
Output Current Limit	I_{OUTLIM}	Output in on-state	30	50	80	mA	
Output Leakage Current	I_{OUTOFF}	$V_{OUT} = 24\text{ V}$, output in off-state	–	0.1	10	μA	
Output Delay Time ⁶	t_d	4 kHz sinusoidal signal, falling electrical edge	–	22	–	μs	
Output Rise Time	t_r	$R_{PU} = 1\text{ k}\Omega$, $C_L = 4.7\text{ nF}$, $V_{PU} = 5\text{ V}$	–	10.3	–	μs	
Output Fall Time ⁷	t_f	$T_A = 25^\circ\text{C}$, $R_{PU} = 1\text{ k}\Omega$, $C_L = 4.7\text{ nF}$	$V_{PU} = 5\text{ V}$	5	8	15	μs
			$V_{PU} = 12\text{ V}$	–	15	–	μs
Output Fall Time Variation Over Temperature Range	Δt_f	Maximum variation from $T_A = 25^\circ\text{C}$	–	± 0.2	–	$\% / ^\circ\text{C}$	
Output Polarity	V_{OUT}	HT device package option	Opposite target tooth	–	High	–	V
			Opposite target valley	–	Low	–	V
		LT device package option	Opposite target tooth	–	Low	–	V
			Opposite target valley	–	High	–	V
Performance Characteristics							
Operational Air Gap Range ⁸	AG_{TPOS}	TPOS functionality guaranteed	0.5	–	3.0	mm	
Extended Air Gap Range ⁹	AG_{EXTMAX}	Output switching in Running Mode, TPOS function not guaranteed	3.0	–	4.5	mm	
Relative Timing Accuracy ^{10,11}	Err_{RELR}	Rising mechanical edges after initial calibration, gear speed = 1000 rpm, target eccentricity < 0.1 mm	–	0.4	0.8	deg.	
	Err_{RELF}	Falling mechanical edges after initial calibration, gear speed = 1000 rpm, target eccentricity < 0.1 mm	–	0.5	1.0	deg.	

Continued on the next page...

OPERATING CHARACTERISTICS (continued) Valid using reference target 8X, T_A , T_J , and V_{CC} within specification, unless otherwise noted

Characteristics	Symbol	Test Conditions	Min.	Typ. ¹	Max.	Unit
Tooth Speed	f_{SIG}	Tooth signal frequency, sinusoidal input signal	0	–	8000	Hz
Analog Signal Bandwidth	BW	Equivalent to –3 dB cutoff frequency	–	20	–	kHz
Switchpoint Characteristics						
Switchpoint	B_{ST}	% of peak-to-peak, referenced to tooth signal (see figure 4)	–	30	–	%
Internal Hysteresis ¹²	B_{HYS}	% of peak-to-peak signal	–	10	–	%
Calibration						
Initial Calibration ¹³	CAL_I	Quantity of mechanical falling edges during which device is in full TPOS Mode	–	–	4	Edges
TPO to Running Mode Adjustment	CAL_{TPORM}	Quantity of target teeth after CAL_I over which TPOS to Running Mode threshold adjustment occurs	1	–	16	Teeth
Signal Characteristics						
Maximum Allowable Signal Reduction ¹⁴	$B_{reduce(G)}$	Reduction in V_{PROC} amplitude from $V_{PROC(high)}$ to lowest peak $V_{PROC(reduce)}$; all specifications within range (see figure 5)	–	–	15	%pk-pk
	$B_{reduce(NG)}$	Reduction in V_{PROC} amplitude from $V_{PROC(high)}$ to lowest peak $V_{PROC(reduce)}$; output switches, other specifications may be out of range (see figure 5)	–	–	25	%pk-pk

¹Typical values are at $T_A = 25^\circ\text{C}$ and $V_{CC} = 12\text{ V}$. Performance may vary for individual units, within the specified maximum and minimum limits.

²Maximum voltage must be adjusted for power dissipation and junction temperature; see Power Derating section.

³Maximum current limit is equal to $I_{CC(max)} + 3\text{ mA}$.

⁴Negative current is defined as conventional current coming out of (sourced from) the specified device terminal.

⁵Power-On Time is the duration from when V_{CC} rises above $V_{CC(min)}$ until a valid output state is realized.

⁶Output Delay Time is the duration from when a crossing of the magnetic signal switchpoint, B_{ST} , occurs to when the electrical output signal, V_{OUT} , reaches 90% of $V_{OUT(high)}$.

⁷Characterization data shows 12 V fall time to be 1.5 times longer than 5 V fall time. See figure 2.

⁸The Operational Air Gap Range is the range of installation air gaps within which the TPOS (True Power-On State) function is guaranteed to correctly detect a tooth when powered-on opposite a tooth and correctly detecting a valley when powered-on opposite a valley, using reference target 8X.

⁹The Extended Air Gap Range is a range of installation air gaps, larger than AG_{TPOS} , within which the device will accurately detect target features in Running Mode, but TPOS functionality is NOT guaranteed, possibly resulting in undetected target features during Initial Calibration. Relative Timing Accuracy (Err_{REL}) not guaranteed in Extended Air Gap Range.

¹⁰The term *mechanical edge* refers to a target feature, such as the side of a gear tooth, passing opposite the device. A rising edge is a transition from a valley to a tooth, and a falling edge is a transition from a tooth to a valley. See figure 7.

¹¹Relative Timing Accuracy refers to the difference in accuracy, relative to a 0.5 mm air gap, through the entire Operational Air Gap Range. See figure 7.

¹²Refer to Functional Description section for a description of Internal Hysteresis.

¹³Signal frequency, $f_{SIG} < 200\text{ Hz}$.

¹⁴Running Mode; 4X target used. The Operational Signal Amplitude, V_{PROC} , is the internal signal generated by the Hall detection circuitry and normalized by Automatic Gain Calibration.

Signal Processing Characteristics

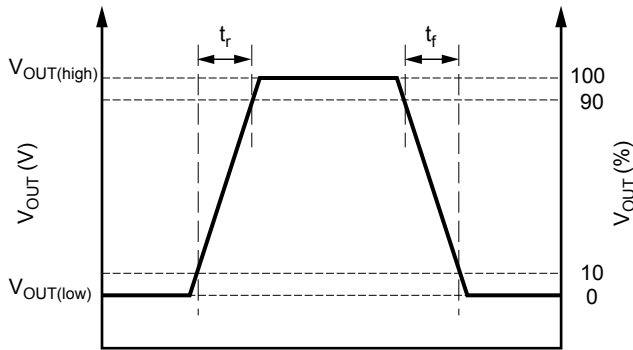

Figure 2. Output Rise Time and Output Fall Time

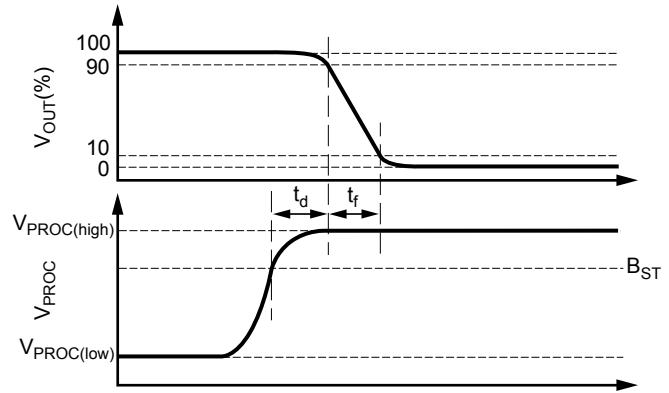

Figure 3. Output Delay Time and Output Fall Time

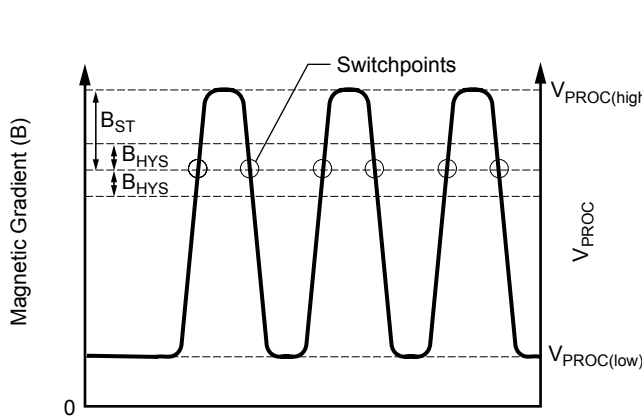

Figure 4. Switchpoint and Internal Hysteresis

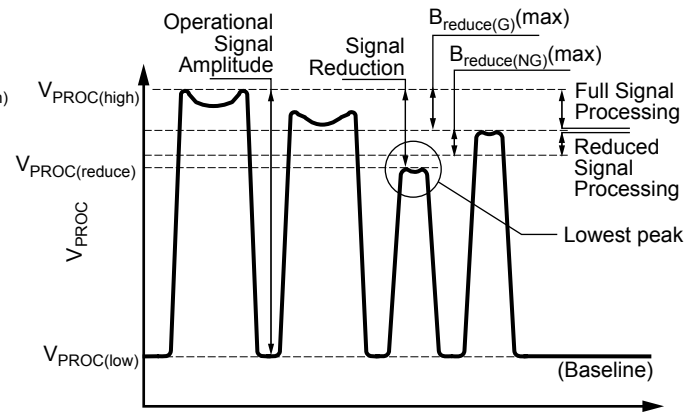
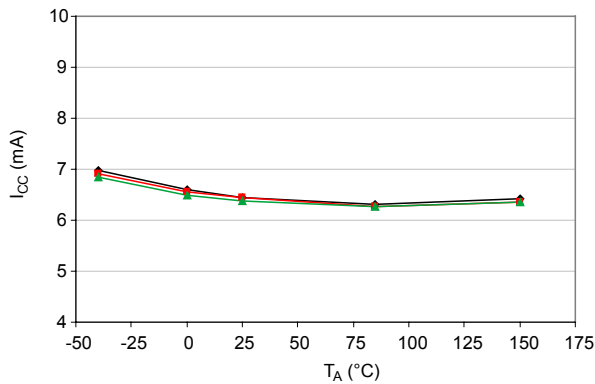

Figure 5. Maximum Allowable Signal Reduction. B_{reduce} for a given tooth signal is calculated as follows:

$$B_{\text{reduce}} = \frac{\text{Signal Reduction}}{\text{Operational Signal Amplitude}} \times 100\%$$

Characteristic Performance

Supply Current versus Ambient Temperature



Output Fall Time Versus Ambient Temperature

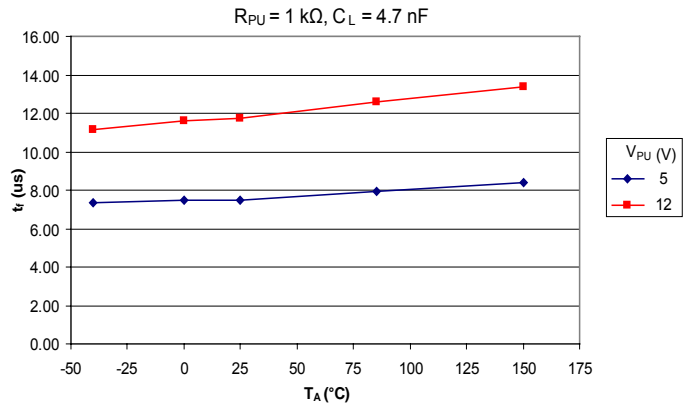

Output Voltage (Low) versus Ambient Temperature

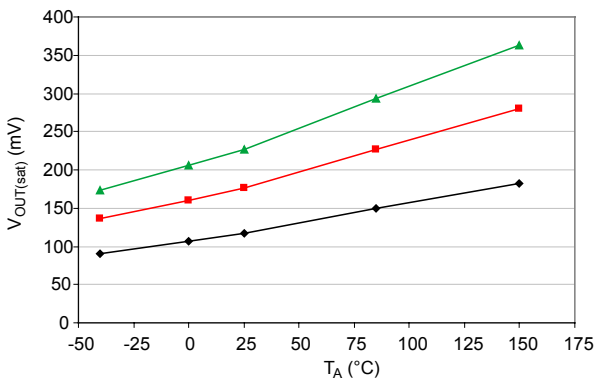

Relative Timing Accuracy versus Air Gap
Falling Mechanical Edge, 1000 rpm, Relative to 0.5 mm Air Gap

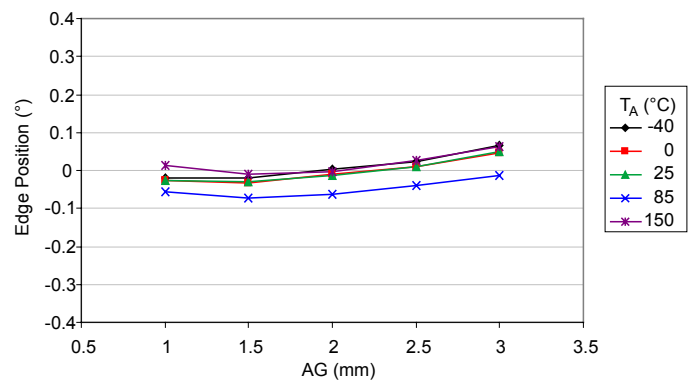

Relative Timing Accuracy versus Air Gap
Rising Mechanical Edge, 1000 rpm, Relative to 0.5 mm Air Gap

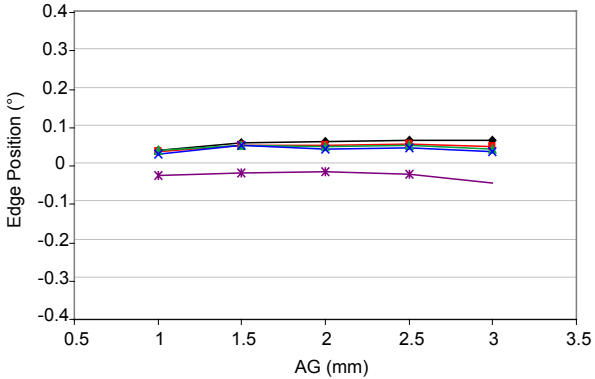

Relative Timing Accuracy versus Speed
T_A = 25°C, 1.5 mm Air Gap, Relative to 0.5 mm Air Gap

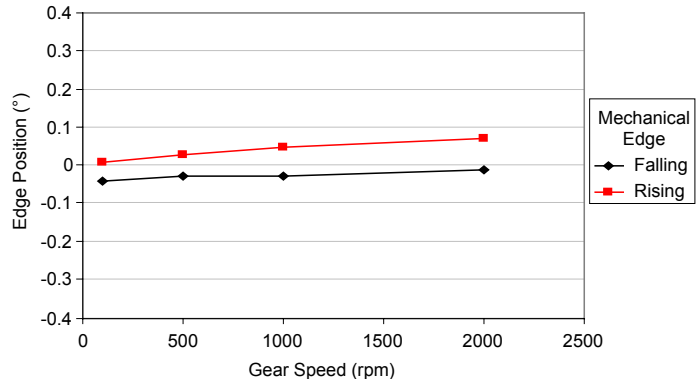

Reference Target 8x

Characteristic	Symbol	Test Conditions	Typ.	Units	Symbol Key
Outside Diameter	D_o	Outside diameter of target	120	mm	
Face Width	F	Breadth of tooth, with respect to sensor	6	mm	
Circular Tooth Length	t	Length of tooth, with respect to sensor; measured at D_o	23.6	mm	
Circular Valley Length	t_v	Length of valley, with respect to sensor; measured at D_o	23.6	mm	
Tooth Whole Depth	h_t		5	mm	
Material		CRS 1018	-	-	

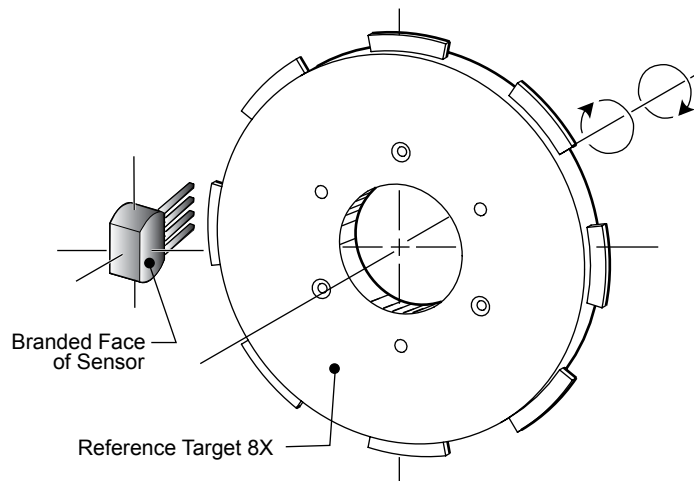

Figure 6. Configuration with Reference Target

Functional Description

Internal Electronics

This device contains a self-calibrating Hall effect IC that provides a Hall element, a temperature compensated amplifier, and offset cancellation circuitry. The IC also contains a voltage regulator that provides supply noise rejection over the operating voltage range. The Hall transducers and the electronics are integrated on the same silicon substrate by a proprietary BiCMOS process. Changes in temperature do not greatly affect this device, due to the stable amplifier design and the offset rejection circuitry.

Sensing Technology

The ATS675 gear tooth sensor contains a single-chip Hall effect sensor IC, a 4-pin leadframe, and a specially designed rare-earth magnet. The Hall IC supports a chopper stabilized Hall element that measures the magnetic gradient created by the passing of a ferrous object. This is illustrated in figure 7. The difference in the magnetic gradients created by teeth and valleys allows the devices to generate a digital output signal that is representative of the target features.

Undervoltage Lockout

When the supply voltage falls below the undervoltage lockout level, V_{CCUV} , the device switches to the off-state. The device remains in that state until the voltage level is restored to the V_{CC} operating range. Changes in the target magnetic profile have no effect until voltage is restored. This prevents false signals caused

by undervoltage conditions from propagating to the output of the sensor.

Power Supply Protection

The ATS675 contains an on-chip regulator and can operate over a wide range of supply voltage levels. For applications using an unregulated power supply, transient protection may be added externally. For applications using a regulated supply line, EMI and RFI protection may still be required. Contact Allegro for information on EMC specification compliance.

Output

After proper power is applied to the device, it is then capable of providing digital information that is representative of the profile of a rotating gear, as illustrated in figure 8. No additional optimization is needed and minimal processing circuitry is required. This ease of use reduces design time and incremental assembly costs for most applications.

Output Polarity

With the LT device option, the polarity of the output is low when the Hall element is opposite a target tooth, and high when opposite a target valley. The output polarity is opposite in the HT option.. This is illustrated in figure 8.

TPOS (True Power-On State) Operation

Under specified operating conditions, the ATS675 is guaranteed

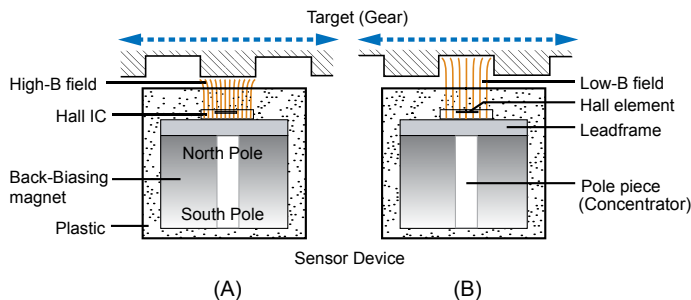

Figure 7. Application cross-section: (A) target tooth opposite device, and (B) target valley opposite device

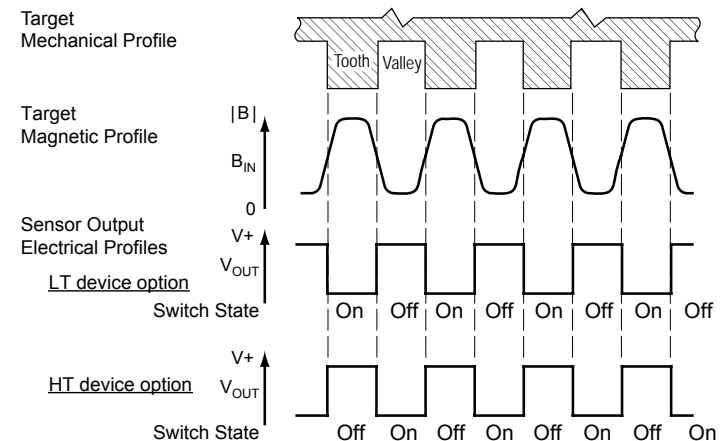

Figure 8. Sensor output polarity and switch state (with device connected as shown in figure 1): with LT option, output is low when a target tooth is opposite the Hall element (device on), and high when a target valley is opposite (device off)—polarity response inverts with the HT option.

to attain the specified output voltage polarity at power-on, in relation to the target feature nearest the device at that time. The TPOS switchpoint is programmed by Allegro to the datasheet specifications.

Start-Up Detection

The ATS675 provides an output polarity transition at the first target mechanical edge that is opposite the device after power-on.

Calibration

The Automatic Gain Calibration (AGC) feature is implemented by a unique patented self-calibrating circuitry. After each power-on, the device measures the peak-to-peak magnetic signal. The gain of the sensor is then adjusted, keeping the internal signal, V_{PROC} , at a constant amplitude throughout the air gap range of the device. This feature ensures that operational characteristics are isolated from the effects of changes in effective air gap. The Initial Calibration process allows the peak detecting DACs to properly acquire the magnetic signal, so that a Running Mode switchpoint can be accurately computed.

TPOS to Running Mode

After the Initial Calibration process is completed (CAL_I), the device transitions to Running Mode. As shown in figure 9, the device dynamically adjusts the relative edge position from the TPOS edge location to the Running Mode location over several target teeth (C_{TPORM}), significantly reducing the maximum tim-

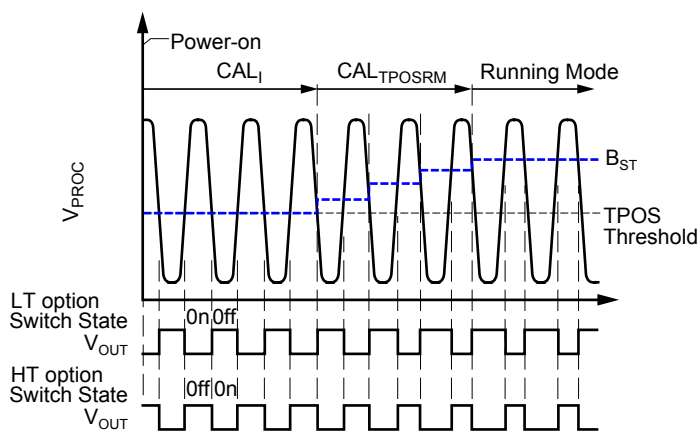

Figure 9. Startup calibration order

ing accuracy step size during startup conditions. A single large jump in edge position is not allowed; instead, any change in edge position from TPOS to Running Mode is spread over several output transitions.

Switchpoints

The Running Mode switchpoints in the ATS675 are established dynamically as a percentage of the amplitude of the signal, V_{PROC} , after normalization with AGC. Two DACs track the peaks of V_{PROC} .

The switching threshold is established at a fixed percentage of the values held in the two DACs. The ATS675 uses a single switching threshold (operate and release points identical) with internal hysteresis.

Internal Hysteresis

The Internal Hysteresis, B_{HYS} , provides high performance over various air gaps while maintaining immunity to false switching on noise, vibration, backlash, or other transient events. Figure 10 demonstrates the function of this hysteresis when switching on an anomalous peak.

Peak and Valley DAC Update

The peak and valley DACs have an algorithm that allows tracking of drift over temperature changes, but provides immunity to target particularities, such as small mechanical valleys.

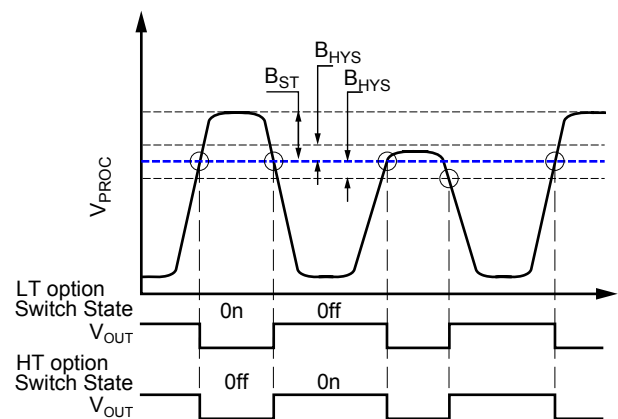

Figure 10. Output switching can accommodate an anomalous peak, such as the middle peak in this figure, by using the Internal Hysteresis value.

Sensor and Target Evaluation

Magnetic Profile

In order to establish the proper operating specification for a particular sensor device and target system, a systematic evaluation of the magnetic circuit should be performed. The first step is the generation of a magnetic map of the target. By using a calibrated device, a magnetic profile of the system is made. Figure 11 is a magnetic map of the 8X reference target.

A pair of curves can be derived from this map data, and be used to describe the tooth and valley magnetic field strength, B , versus the size of the air gap, AG . This allows determination of the minimum amount of magnetic flux density that guarantees operation of the sensor, so the system designer can determine the maximum allowable AG for the sensor and target system. One can also determine the TPOS air gap capabilities of the sensor by comparing the minimum tooth signal to the maximum valley signal.

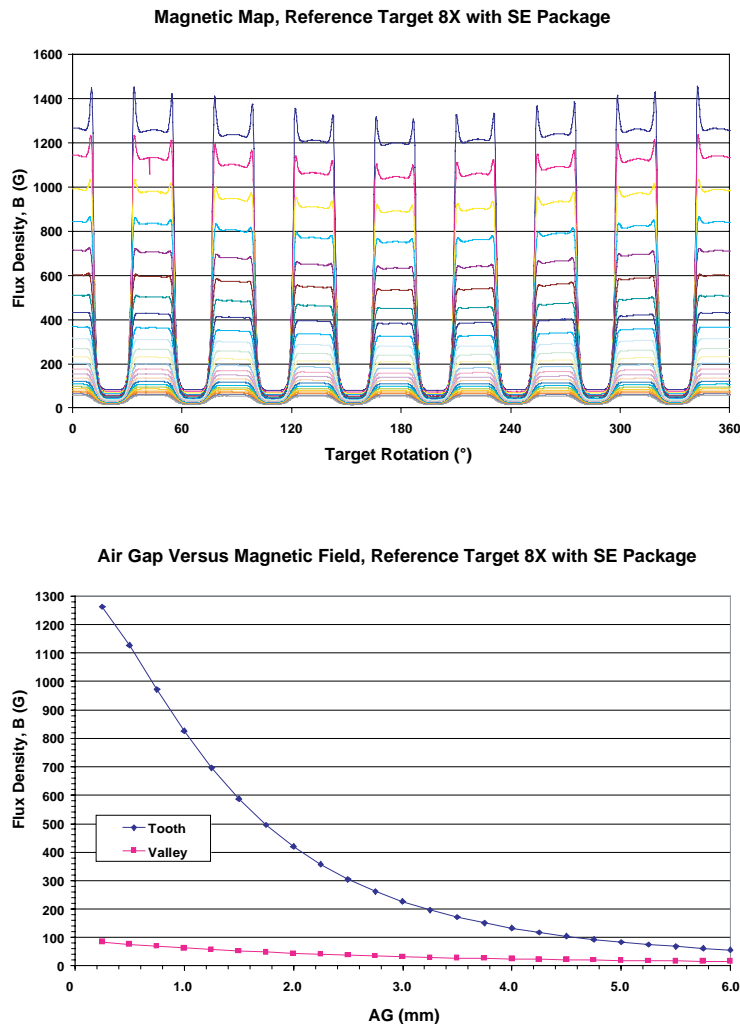

Figure 11. Magnetic Data for the 8X Reference Target and SE package. Flux density measurements are relative to the baseline magnetic field.

Power Derating

The device must be operated below the maximum junction temperature of the device, $T_{J(max)}$. Under certain combinations of peak conditions, reliable operation may require derating supplied power or improving the heat dissipation properties of the application. This section presents a procedure for correlating factors affecting operating T_J . (Thermal data is also available on the Allegro MicroSystems website.)

The Package Thermal Resistance, $R_{\theta JA}$, is a figure of merit summarizing the ability of the application and the device to dissipate heat from the junction (die), through all paths to the ambient air. Its primary component is the Effective Thermal Conductivity, K , of the printed circuit board, including adjacent devices and traces. Radiation from the die through the device case, $R_{\theta JC}$, is relatively small component of $R_{\theta JA}$. Ambient air temperature, T_A , and air motion are significant external factors, damped by overmolding.

The effect of varying power levels (Power Dissipation, P_D), can be estimated. The following formulas represent the fundamental relationships used to estimate T_J , at P_D .

$$P_D = V_{IN} \times I_{IN} \quad (1)$$

$$\Delta T = P_D \times R_{\theta JA} \quad (2)$$

$$T_J = T_A + \Delta T \quad (3)$$

For example, given common conditions such as: $T_A = 25^\circ\text{C}$, $V_{CC} = 12\text{ V}$, $I_{CC} = 7\text{ mA}$, and $R_{\theta JA} = 77\text{ }^\circ\text{C/W}$, then:

$$P_D = V_{CC} \times I_{CC} = 12\text{ V} \times 7\text{ mA} = 84\text{ mW}$$

$$\Delta T = P_D \times R_{\theta JA} = 84\text{ mW} \times 77\text{ }^\circ\text{C/W} = 6.5^\circ\text{C}$$

$$T_J = T_A + \Delta T = 25^\circ\text{C} + 6.5^\circ\text{C} = 31.5^\circ\text{C}$$

A worst-case estimate, $P_{D(max)}$, represents the maximum allowable power level, without exceeding $T_{J(max)}$, at a selected $R_{\theta JA}$ and T_A .

Example: Reliability for V_{CC} at $T_A = 150^\circ\text{C}$.

Observe the worst-case ratings for the device, specifically: $R_{\theta JA} = 101\text{ }^\circ\text{C/W}$, $T_{J(max)} = 165^\circ\text{C}$, $V_{CC(max)} = 24\text{ V}$, and $I_{CC(max)} = 10\text{ mA}$.

Calculate the maximum allowable power level, $P_{D(max)}$. First, invert equation 3:

$$\Delta T(max) = T_{J(max)} - T_A = 165^\circ\text{C} - 150^\circ\text{C} = 15^\circ\text{C}$$

This provides the allowable increase to T_J resulting from internal power dissipation.

Then, invert equation 2:

$$P_{D(max)} = \Delta T(max) \div R_{\theta JA} = 15^\circ\text{C} \div 101\text{ }^\circ\text{C/W} = 148.5\text{ mW}$$

Finally, invert equation 1 with respect to voltage:

$$V_{CC(est)} = P_{D(max)} \div I_{CC(max)} = 148.5\text{ mW} \div 10\text{ mA} = 14.9\text{ V}$$

The result indicates that, at T_A , the application and device can dissipate adequate amounts of heat at voltages $\leq V_{CC(est)}$.

Compare $V_{CC(est)}$ to $V_{CC(max)}$. If $V_{CC(est)} \leq V_{CC(max)}$, then reliable operation between $V_{CC(est)}$ and $V_{CC(max)}$ requires enhanced $R_{\theta JA}$. If $V_{CC(est)} \geq V_{CC(max)}$, then operation between $V_{CC(est)}$ and $V_{CC(max)}$ is reliable under these conditions.

Package SE 4-Pin SIP Module

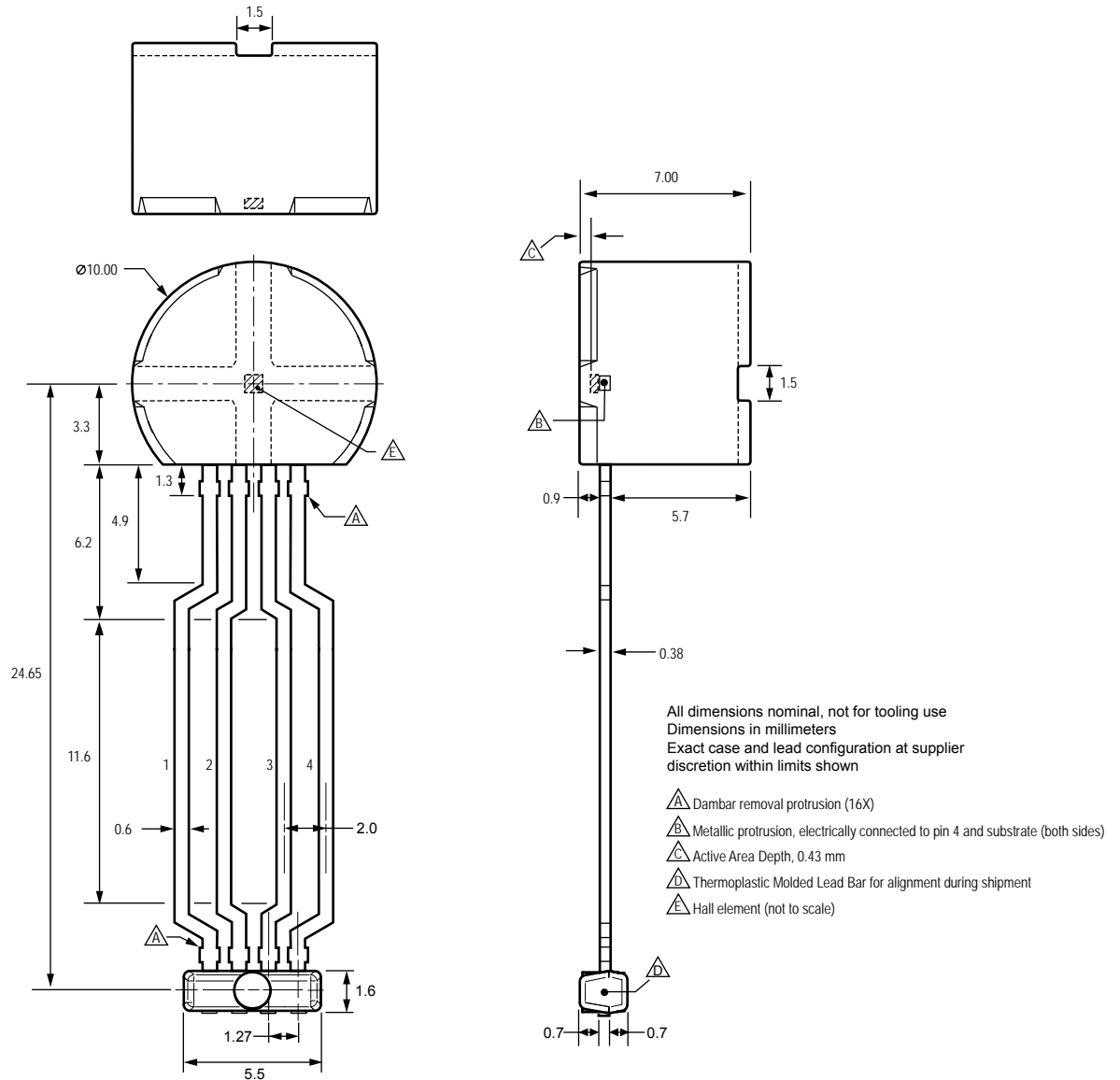

Copyright ©2008, Allegro MicroSystems, Inc.

The products described herein are manufactured under one or more of the following U.S. patents: 5,045,920; 5,264,783; 5,442,283; 5,389,889; 5,581,179; 5,517,112; 5,619,137; 5,621,319; 5,650,719; 5,686,894; 5,694,038; 5,729,130; 5,917,320; and other patents pending.

Allegro MicroSystems, Inc. reserves the right to make, from time to time, such departures from the detail specifications as may be required to permit improvements in the performance, reliability, or manufacturability of its products. Before placing an order, the user is cautioned to verify that the information being relied upon is current.

Allegro's products are not to be used in life support devices or systems, if a failure of an Allegro product can reasonably be expected to cause the failure of that life support device or system, or to affect the safety or effectiveness of that device or system.

The information included herein is believed to be accurate and reliable. However, Allegro MicroSystems, Inc. assumes no responsibility for its use; nor for any infringement of patents or other rights of third parties which may result from its use.

For the latest version of this document, visit our website:

www.allegromicro.com



Allegro MicroSystems, Inc.
115 Northeast Cutoff
Worcester, Massachusetts 01615-0036 U.S.A.
1.508.853.5000; www.allegromicro.com