



DESCRIPTION

The AMS1073 is a monolithic step-down switch mode converter with a built-in power MOSFET. It achieves 1.2A peak output current over a wide input supply range with excellent load and line regulation. Current mode operation provides fast transient response and eases loop stabilization. Fault condition protection includes cycle-by-cycle current limiting and thermal shutdown.

The AMS1073 requires a minimum number of readily available standard external components. The AMS1073 is available in SOT23-6 packages.

FEATURES

- 1.2A Peak Output Current
- 0.35Ω Internal Power MOSFET Switch
- Stable with Low ESR Output Ceramic Capacitors
- Up to 92% Efficiency
- 0.1μA Shutdown Mode
- Fixed 1.4MHz Frequency
- Thermal Shutdown
- Cycle-by-Cycle Over Current Protection
- Wide 4.5V to 24V Operating Input Range
- Output Adjustable from 0.81V to 15V
- Available in SOT23-6 Packages

APPLICATIONS

- Distributed Power Systems
- Battery Charger
- Pre-Regulator for Linear Regulators
- WLED Drivers

TYPICAL APPLICATION

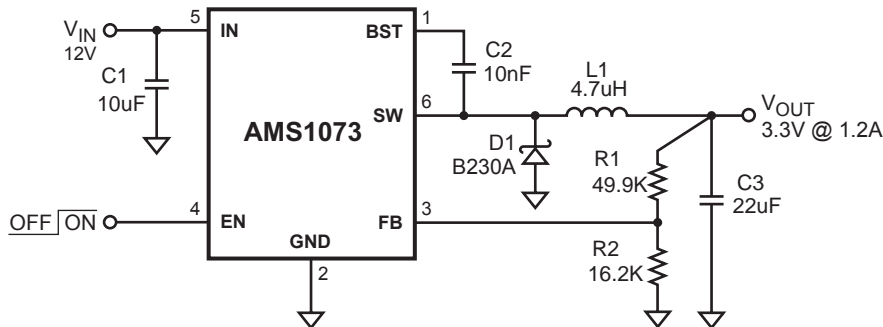



ORDERING INFORMATION

Part Number	Package	Top Marking	Free Air Temperature (T _A)
AMS1073	SOT23-6		-40°C to +85°C

PACKAGE REFERENCE

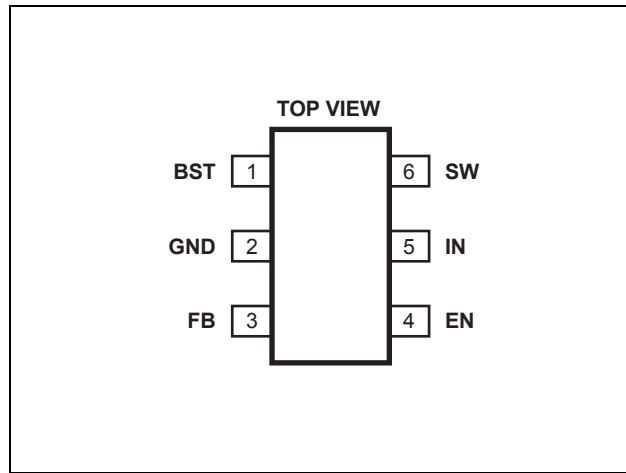

ABSOLUTE MAXIMUM RATINGS ⁽¹⁾

Supply Voltage V _{IN}	-0.3V~ 26V
V _{SW}	-0.3V~Vin+0.3V
V _{BS}	V _{SW} + 6V
All Other Pins	-0.3V to +6V
Continuous Power Dissipation (T _A = +25°C) ⁽²⁾	
SOT23-6	0.568W

Junction Temperature	150°C
Lead Temperature	260°C
Storage Temperature.....	-65°C to +150°C

Recommended Operating Conditions ⁽³⁾

Supply Voltage V _{IN}	4.5V to 24V
Output Voltage V _{OUT}	0.81V to 15V
Ambient Temperature	-40°C to +85°C
Max input current into the EN pin.....	300µA

Thermal Resistance ⁽⁴⁾	θ _{JA}	θ _{JC}
SOT23-6	220	110.. °C/W

Notes:

- 1) Exceeding these ratings may damage the device.
- 2) The maximum allowable power dissipation is a function of the maximum junction temperature T_J(MAX), the junction-to-ambient thermal resistance θ_{JA}, and the ambient temperature T_A. The maximum allowable continuous power dissipation at any ambient temperature is calculated by P_D(MAX)=(T_J(MAX)-T_A)/θ_{JA}. Exceeding the maximum allowable power dissipation will cause excessive die temperature, and the regulator will go into thermal shutdown. Internal thermal shutdown circuitry protects the device from permanent damage.
- 3) The device function is not guaranteed outside of the recommended operating conditions.
- 4) Measured on JESD51-7, 4-layer PCB..



ELECTRICAL CHARACTERISTICS

$V_{IN} = 12V$, $T_A = +25^\circ C$, unless otherwise noted.

Parameters	Symbol	Condition	Min	Typ	Max	Units
Feedback Voltage	V_{FB}	$4.5V \leq V_{IN} \leq 24V$	0.790	0.810	0.830	V
Feedback Current	I_{FB}	$V_{FB} = 0.8V$		0.1		μA
Switch-On Resistance ⁽⁵⁾	$R_{DS(ON)}$			0.35		Ω
Switch Leakage		$V_{EN} = 0V, V_{SW} = 0V$			10	μA
Current Limit ⁽⁵⁾				1.8		A
Oscillator Frequency	f_{SW}	$V_{FB} = 0.6V$	1.2	1.4	1.7	MHz
Fold-back Frequency		$V_{FB} = 0V$		460		kHz
Maximum Duty Cycle		$V_{FB} = 0.6V$		87		%
Minimum On-Time ⁽⁵⁾	t_{ON}			100		ns
Under Voltage Lockout Threshold Rising			2.5	2.8	3.1	V
Under Voltage Lockout Threshold Hysteresis				150		mV
EN Input Low Voltage					0.4	V
EN Input High Voltage			1.2			V
EN Input Current		$V_{EN} = 2V$		2.1		μA
		$V_{EN} = 0V$		0.1		
Supply Current (Shutdown)	I_S	$V_{EN} = 0V$		0.1	1.0	μA
Supply Current (Quiescent)	I_Q	$V_{EN} = 2V, V_{FB} = 1V$		0.8	1.0	mA
Thermal Shutdown ⁽⁵⁾				150		$^\circ C$

Note:

5) Guaranteed by design.

PIN FUNCTIONS

Pin #	Name	Description
1	BST	Bootstrap. A capacitor is connected between SW and BS pins to form a floating supply across the power switch driver. This capacitor is needed to drive the power switch's gate above the supply voltage.
2	GND	Ground. This pin is the voltage reference for the regulated output voltage. For this reason care must be taken in its layout. This node should be placed outside of the D1 to C1 ground path to prevent switching current spikes from inducing voltage noise into the part.
3	FB	Feedback. An external resistor divider from the output to GND, tapped to the FB pin sets the output voltage. To prevent current limit run away during a short circuit fault condition, the frequency foldback comparator lowers the oscillator frequency when the FB voltage is below 250mV.
4	EN	On/Off Control Input. Pull EN above 1.2V to turn the device on. For automatic enable, connect a 100k Ω resistor between this pin and Vin pin.
5	IN	Supply Voltage. The AMS1073 operates from a +4.5V to +24V unregulated input. C1 is needed to prevent large voltage spikes from appearing at the input.
6	SW	Switch Output.



Functional Block Diagram

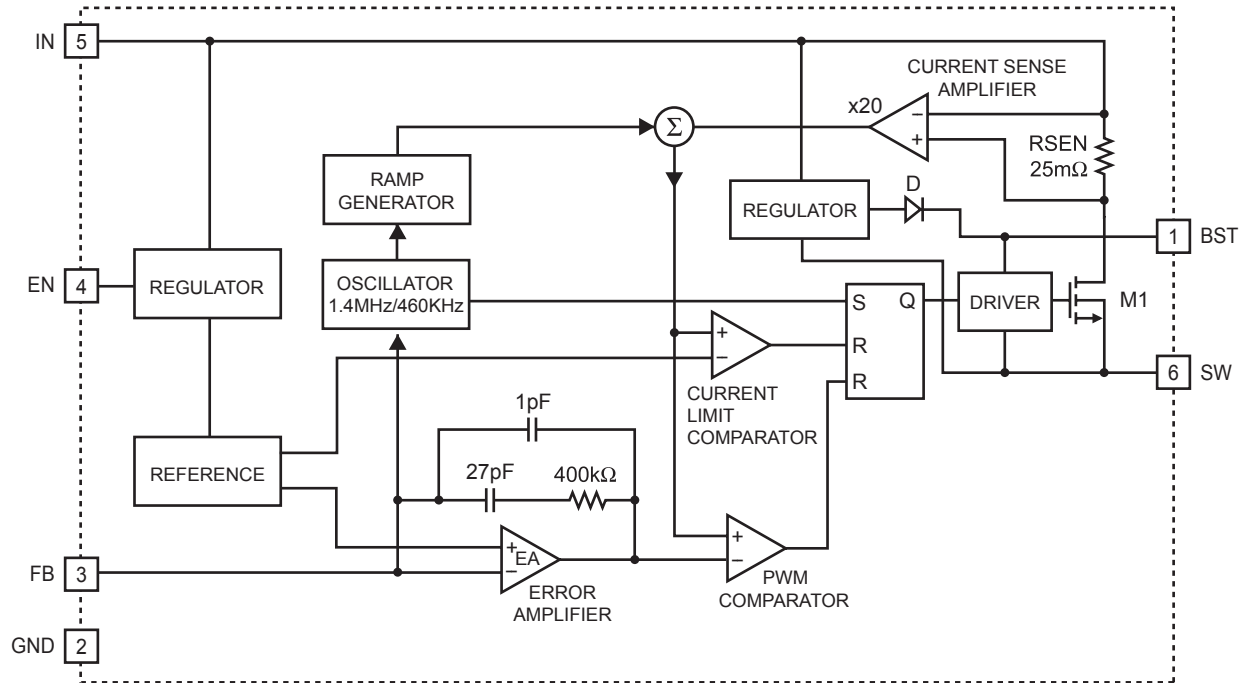



TYPICAL APPLICATION CIRCUITS

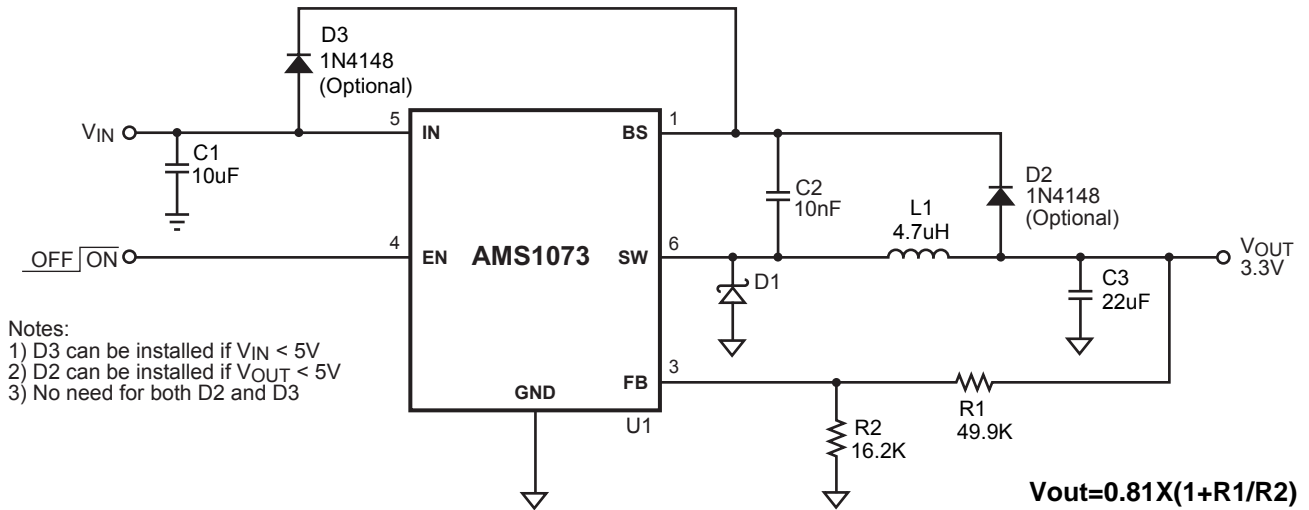

1.4MHz, 3.3V Output at 1A Step-Down Converter

Resistor Selection for Common Output Voltages

V_{OUT} (V)	R1 (k Ω)	R2 (k Ω)
1.8	80.6 (1%)	64.9 (1%)
2.5	49.9 (1%)	23.7 (1%)
3.3	49.9 (1%)	16.2 (1%)
5	49.9 (1%)	9.53 (1%)



SOT23-6

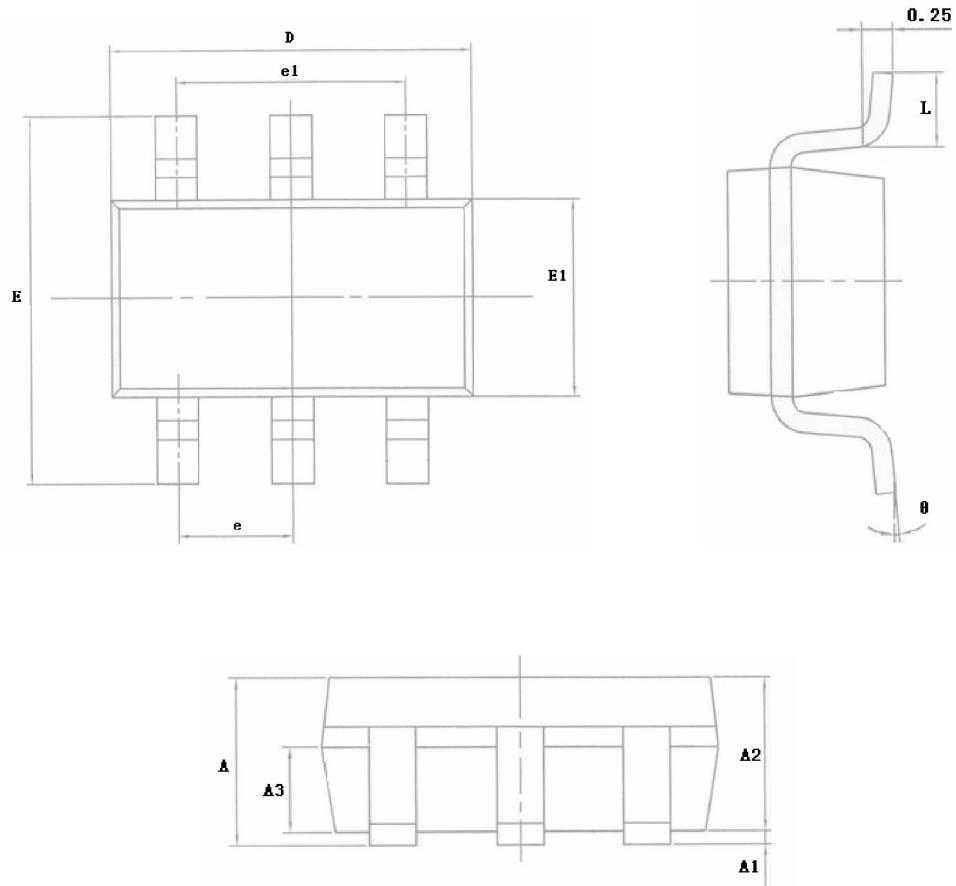

SYMBOL	MILLIMETER		
	MIN	NOR	MAX
A	-	-	1.35
A1	0.04	-	0.15
A2	1.00	1.10	1.20
A3	0.55	0.65	0.75
D	2.72	2.92	3.12
E	2.60	2.80	3.0
E1	1.40	1.60	1.80
e	0.95BSC		
e1	1.90BSC		
L	0.30	-	0.60
θ	0	-	8°