

# P4C1026

## ULTRA HIGH SPEED 256K x 4

### STATIC CMOS RAM



#### FEATURES

- Full CMOS, 6T Cell
- High Speed (Equal Access and Cycle Times)
  - 15/20/25/35 ns (Commercial/Industrial)
  - 20/25/35 ns (Military)
- Low Power
- Single 5V±10% Power Supply
- Data Retention with 2.0V Supply
- Three-State Outputs
- TTL/CMOS Compatible Outputs
- Fully TTL Compatible Inputs
- Standard Pinout (JEDEC Approved)
  - 28-Pin 300 mil SOJ
  - 28-Pin 400 mil SOJ
  - 28-Pin 400 mil Ceramic DIP
  - 32-Pin Ceramic LCC



#### DESCRIPTION

The P4C1026 is a 1 Meg ultra high speed static RAM organized as 256Kx4. The CMOS memory requires no clock or refreshing and has equal access and cycle times. Inputs and outputs are fully TTL-compatible. The RAM operates from a single 5V±10% tolerance power supply. With battery backup, data integrity is maintained for supply voltages down to 2.0V.

Access times as fast as 15 nanoseconds are available, permitting greatly enhanced system speeds. CMOS is utilized to reduce power consumption.

The P4C1026 is available in a 28-pin 300 mil and 400 mil SOJ packages, as well as Ceramic DIP and LCC packages, providing excellent board level densities.



#### FUNCTIONAL BLOCK DIAGRAM

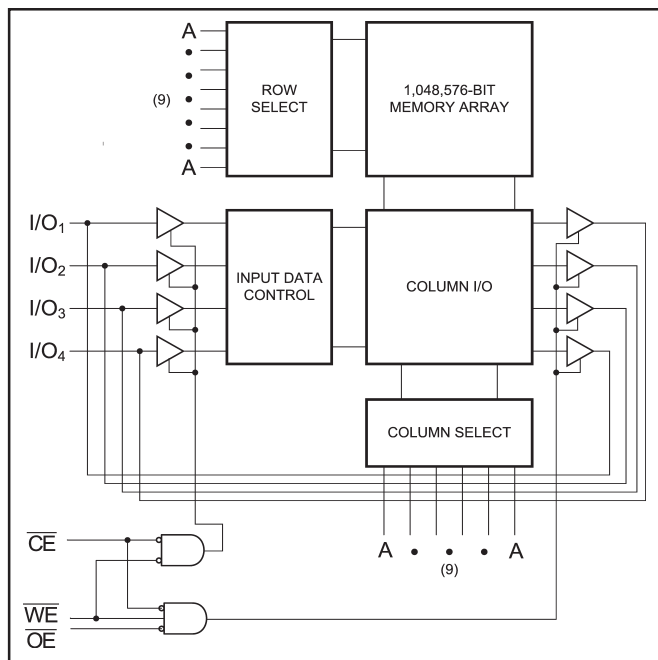

#### PIN CONFIGURATION

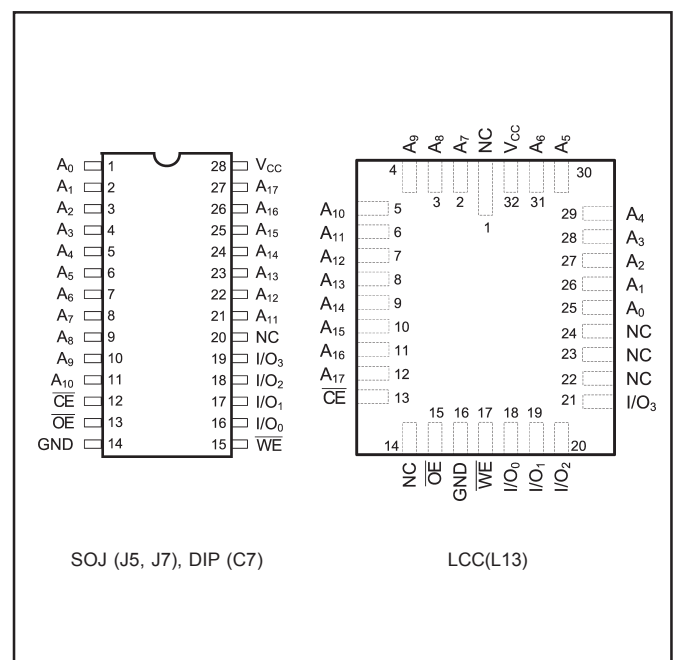

## MAXIMUM RATINGS<sup>(1)</sup>

Symbol	Parameter	Value	Unit
$V_{CC}$	Power Supply Pin with Respect to GND	-0.5 to +7	V
$V_{TERM}$	Terminal Voltage with Respect to GND (up to 7.0V)	-0.5 to $V_{CC} + 0.5$	V
$T_A$	Operating Temperature	-55 to +125	°C

Symbol	Parameter	Value	Unit
$T_{BIAS}$	Temperature Under Bias	-55 to +125	°C
$T_{STG}$	Storage Temperature	-65 to +150	°C
$P_T$	Power Dissipation	1.0	W
$I_{OUT}$	DC Output Current	50	mA

## RECOMMENDED OPERATING TEMPERATURE AND SUPPLY VOLTAGE

Grade(2)	Ambient Temperature	GND	$V_{CC}$
Industrial	-40°C to +85°C	0V	5.0V ± 10%
Commercial	0°C to +70°C	0V	5.0V ± 10%
Military	-55°C to +125°C	0V	5.0V ± 10%

## CAPACITANCES<sup>(4)</sup>

$V_{CC} = 5.0V$ ,  $T_A = 25^\circ C$ ,  $f = 1.0MHz$

Symbol	Parameter	Conditions	Typ.	Unit
$C_{IN}$	Input Capacitance	$V_{IN} = 0V$	7	pF
$C_{OUT}$	Output Capacitance	$V_{OUT} = 0V$	10	pF

## DC ELECTRICAL CHARACTERISTICS

Over recommended operating temperature and supply voltage<sup>(2)</sup>

Symbol	Parameter	Test Conditions	P4C1026		Unit
			Min	Max	
$V_{IH}$	Input High Voltage		2.2	$V_{CC} + 0.5$	V
$V_{IL}$	Input Low Voltage		-0.5 <sup>(3)</sup>	0.8	V
$V_{HC}$	CMOS Input High Voltage		$V_{CC} - 0.2$	$V_{CC} + 0.5$	V
$V_{LC}$	CMOS Input Low Voltage		-0.5 <sup>(3)</sup>	0.2	V
$V_{CD}$	Input Clamp Diode Voltage	$V_{CC} = \text{Min.}, I_{IN} = -18 \text{ mA}$		-1.2	V
$V_{OL}$	Output Low Voltage (TTL Load)	$I_{OL} = +8 \text{ mA}, V_{CC} = \text{Min.}$		0.4	V
$V_{OH}$	Output High Voltage (TTL Load)	$I_{OH} = -4 \text{ mA}, V_{CC} = \text{Min.}$	2.4		V
$I_{LI}$	Input Leakage Current	$V_{CC} = \text{Max.}$ $V_{IN} = \text{GND to } V_{CC}$	-5	+5	μA
$I_{LO}$	Output Leakage Current	$V_{CC} = \text{Max.}, \overline{CE} = V_{IH}$ $V_{OUT} = \text{GND to } V_{CC}$	-5	+5	μA
$I_{SB}$	Standby Power Supply Current (TTL Input Levels)	$\overline{CE} \geq V_{IH}$ $V_{CC} = \text{Max.}, f = \text{Max.}, \text{Outputs Open}$	—	35	mA
$I_{SB1}$	Standby Power Supply Current (CMOS Input Levels)	$\overline{CE} \geq V_{HC}$ $V_{CC} = \text{Max.}, f = 0, \text{Outputs Open}$ $V_{IN} \leq V_{LC} \text{ or } V_{IN} \geq V_{HC}$	—	10	mA

### POWER DISSIPATION CHARACTERISTICS VS. SPEED

Symbol	Parameter	Temperature Range	-15	-20	-25	-35	Unit
			Commercial	75	75	75	
I <sub>CC</sub>	Dynamic Operating Current*	Commercial	80	75	75	75	mA
		Industrial	90	80	80	80	mA

\*V<sub>CC</sub> = 5.5V. Tested with outputs open. f = Max. Switching inputs are 0V and 3V.  $\overline{CE} = V_{IL}$

### DATA RETENTION CHARACTERISTICS

Symbol	Parameter	Test Conditions	Min	Typ.*		Max		Unit
				V <sub>CC</sub> = 2.0V	V <sub>CC</sub> = 3.0V	V <sub>CC</sub> = 2.0V	V <sub>CC</sub> = 3.0V	
V <sub>DR</sub>	V <sub>CC</sub> for Data Retention		2.0					V
I <sub>CCDR</sub>	Data Retention Current	$\overline{CE} \geq V_{CC} - 0.2V,$ $V_{IN} \geq V_{CC} - 0.2V$ or $V_{IN} \leq 0.2V$		10	15	250	500	μA
t <sub>CDR</sub>	Chip Deselect to Data Retention Time		0					ns
t <sub>R</sub> <sup>†</sup>	Operation Recovery Time		t <sub>RC</sub> <sup>§</sup>					ns

\*T<sub>A</sub> = +125°C

§t<sub>RC</sub> = Read Cycle Time

† This parameter is guaranteed but not tested.

### DATA RETENTION WAVEFORM

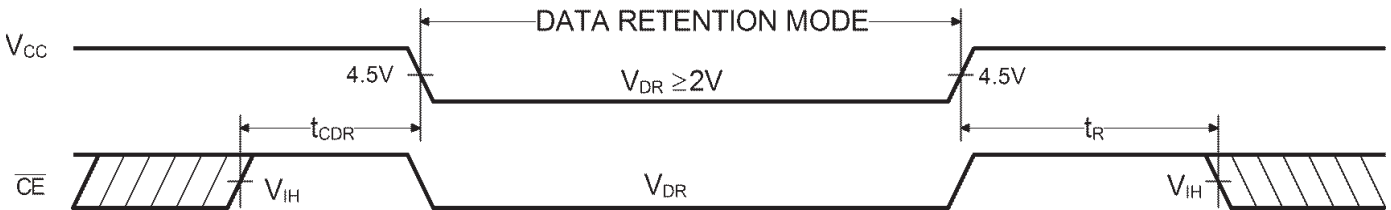

## AC CHARACTERISTICS—READ CYCLE

( $V_{CC} = 5V \pm 10\%$ , All Temperature Ranges)<sup>(2)</sup>

Sym.	Parameter	-15		-20		-25		-35		Unit
		Min	Max	Min	Max	Min	Max	Min	Max	
$t_{RC}$	Read Cycle Time	15		20		25		35		ns
$t_{AA}$	Address Access Time		15		20		25		35	ns
$t_{AC}$	Chip Enable Access Time		15		20		25		35	ns
$t_{OH}$	Output Hold from Address Change	2		2		2		2		ns
$t_{LZ}$	Chip Enable to Output in Low Z	2		3		3		3		ns
$t_{HZ}$	Chip Disable to Output in High Z		8		9		10		11	ns
$t_{PU}$	Chip Enable to Power Up Time	0		0		0		0		ns
$t_{PD}$	Chip Disable to Power Down Time		15		20		25		35	ns

### TIMING WAVEFORM OF READ CYCLE NO. 1 ( $\overline{OE}$ CONTROLLED)<sup>(5)</sup>

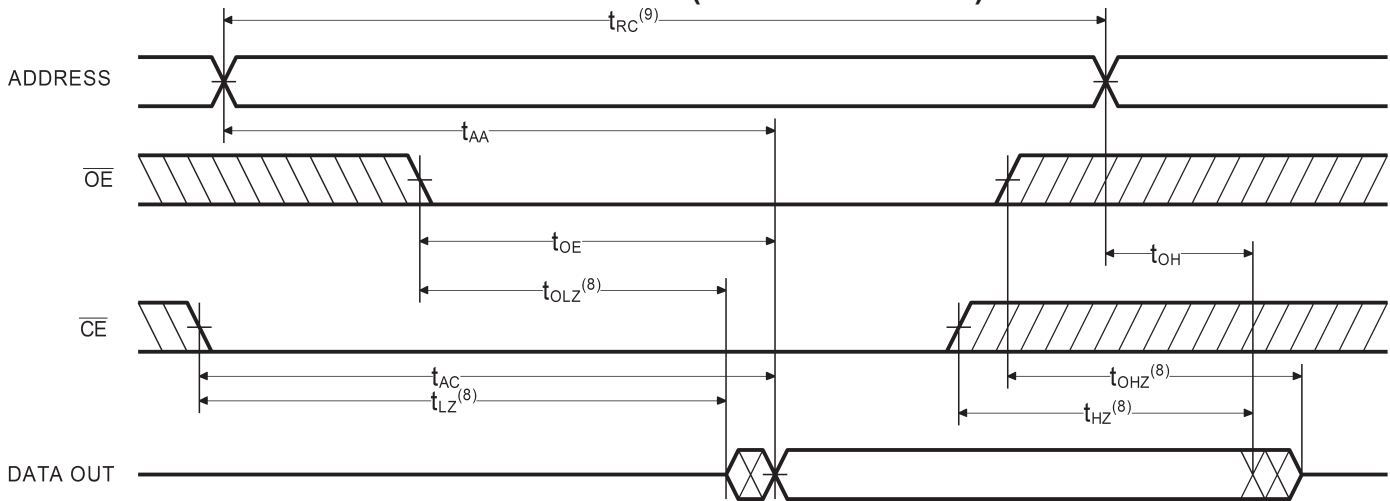

### TIMING WAVEFORM OF READ CYCLE NO. 2 (ADDRESS CONTROLLED)<sup>(5,6)</sup>

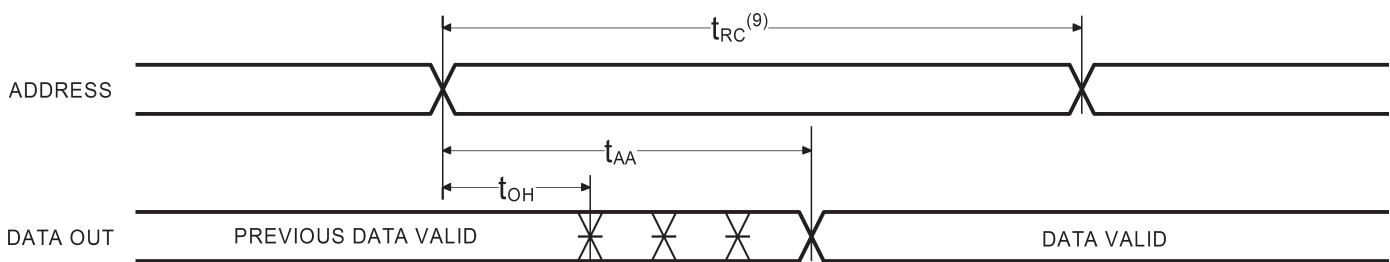

**Notes:**

- Stresses greater than those listed under MAXIMUM RATINGS may cause permanent damage to the device. This is a stress rating only and functional operation of the device at these or any other conditions above those indicated in the operational sections of this specification is not implied. Exposure to MAXIMUM rating conditions for extended periods may affect reliability.
- Extended temperature operation guaranteed with 400 linear feet per minute of air flow.
- Transient inputs with  $V_{IL}$  and  $I_{IL}$  not more negative than  $-3.0V$  and  $-100mA$ , respectively, are permissible for pulse widths up to 20 ns.
- This parameter is sampled and not 100% tested.
- $\overline{WE}$  is HIGH for READ cycle.
- $\overline{CE}$  is LOW and  $\overline{OE}$  is LOW for READ cycle.
- ADDRESS must be valid prior to, or coincident with  $\overline{CE}$  transition LOW.
- Transition is measured  $\pm 200$  mV from steady state voltage prior to change, with loading as specified in Figure 1. This parameter is sampled and not 100% tested.
- Read Cycle Time is measured from the last valid address to the first transitioning address.

**TIMING WAVEFORM OF READ CYCLE NO. 3 (CE CONTROLLED)<sup>(5,7)</sup>**

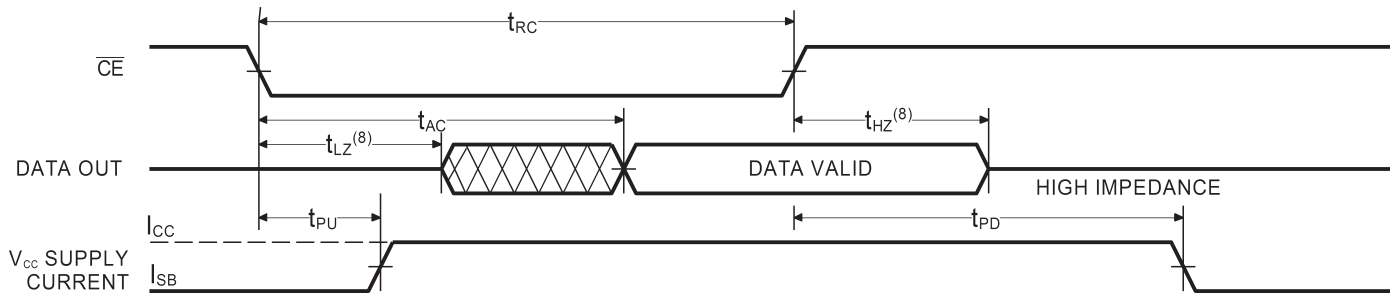

**AC CHARACTERISTICS - WRITE CYCLE**

(V<sub>CC</sub> = 5V ± 10%, All Temperature Ranges)<sup>(2)</sup>

Sym.	Parameter	-15		-20		-25		-35		Unit
		Min	Max	Min	Max	Min	Max	Min	Max	
t <sub>WC</sub>	Write Cycle Time	13		20		25		35		ns
t <sub>CW</sub>	Chip Enable Time to End of Write	12		15		18		25		ns
t <sub>AW</sub>	Address Valid to End of Write	12		15		18		25		ns
t <sub>AS</sub>	Address Set-up Time	0		0		0		0		ns
t <sub>WP</sub>	Write Pulse Width	12		15		18		25		ns
t <sub>AH</sub>	Address Hold Time from End of Write	0		0		0		0		ns
t <sub>DW</sub>	Data Valid to End of Write	7		8		10		15		ns
t <sub>DH</sub>	Data Hold Time	0		0		0		0		ns
t <sub>WZ</sub>	Write Enable to Output in High Z		6		8		10		15	ns
t <sub>DW</sub>	Output Active from End of Write	2		2		2		3		ns

**TIMING WAVEFORM OF WRITE CYCLE NO. 1 (WE CONTROLLED)<sup>(10,11)</sup>**

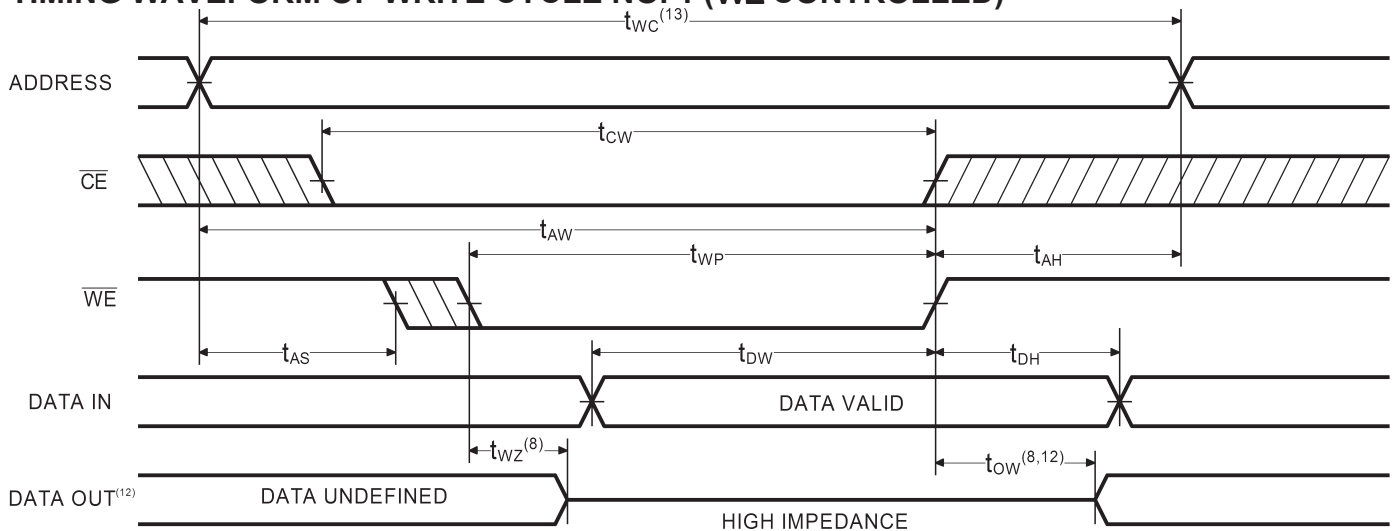

**Notes:**

- 10.  $\overline{CE}$  and  $\overline{WE}$  must be LOW for WRITE cycle.
- 11.  $\overline{OE}$  is LOW for this WRITE cycle to show  $t_{WZ}$  and  $t_{OW}$ .
- 12. If  $\overline{CE}$  goes HIGH simultaneously with  $\overline{WE}$  HIGH, the output remains in a high impedance state

- 13. Write Cycle Time is measured from the last valid address to the first transitioning address.

### TIMING WAVEFORM OF WRITE CYCLE NO. 2 ( $\overline{CE}$ CONTROLLED)<sup>(10)</sup>

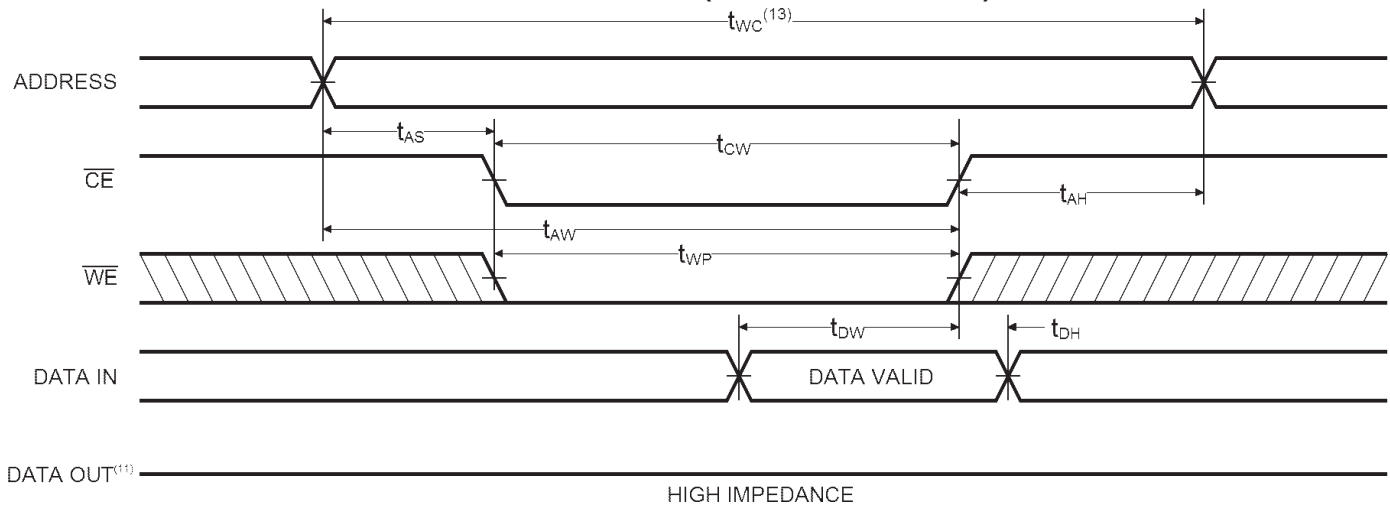

### AC TEST CONDITIONS

Input Pulse Levels	GND to 3.0V
Input Rise and Fall Times	3ns
Input Timing Reference Level	1.5V
Output Timing Reference Level	1.5V
Output Load	See Figures 1 and 2

### TRUTH TABLE

Mode	$\overline{CE}$	$\overline{OE}$	$\overline{WE}$	I/O	Power
Standby	H	X	X	High Z	Standby
$D_{OUT}$ Disabled	L	H	H	High Z	Active
Read	L	L	H	$D_{OUT}$	Active
Write	L	X	L	High Z	Active

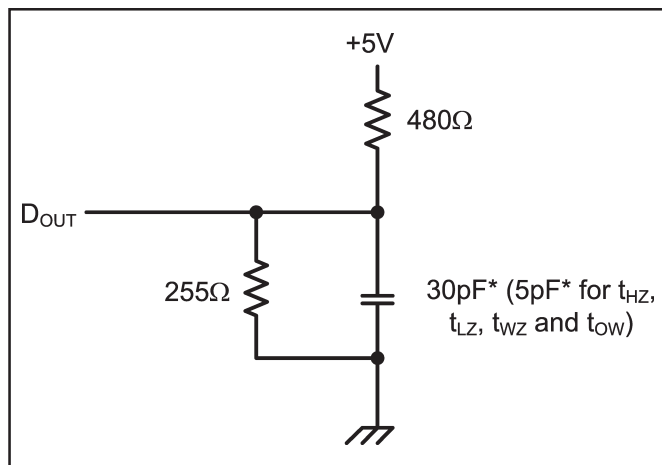

Figure 1. Output Load

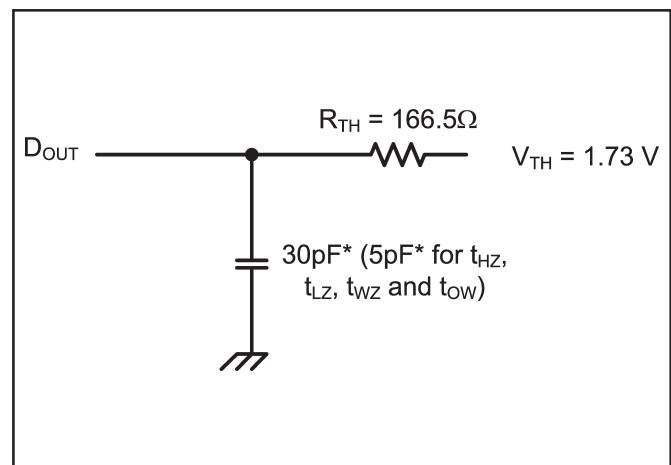

Figure 2. Thevenin Equivalent

\* including scope and test fixture.

**Note:**

Because of the ultra-high speed of the P4C1258, care must be taken when testing this device; an inadequate setup can cause a normal functioning part to be rejected as faulty. Long high-inductance leads that cause supply bounce must be avoided by bringing the  $V_{CC}$  and ground planes directly up to the contactor fingers. A 0.01  $\mu F$  high

frequency capacitor is also required between  $V_{CC}$  and ground. To avoid signal reflections, proper termination must be used; for example, a 50 $\Omega$  test environment should be terminated into a 50 $\Omega$  load with 1.73V (Thevenin Voltage) at the comparator input, and a 116 $\Omega$  resistor must be used in series with  $D_{OUT}$  to match 166 $\Omega$  (Thevenin Resistance).

## ORDERING INFORMATION

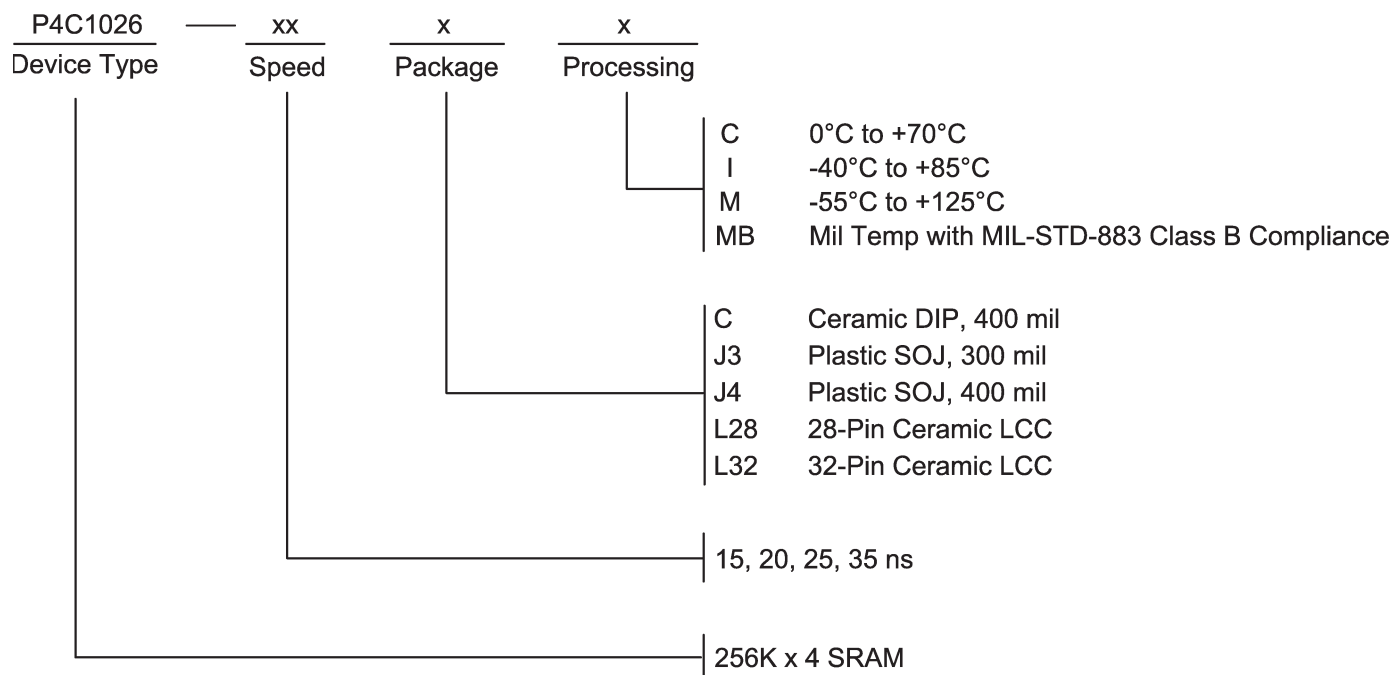

## SELECTION GUIDE

The P4C1026 is available in the following temperature, speed and package options.

Temperature Range	Package	Speed			
		15	20	25	35
Commercial	Plastic SOJ, 300 mil	-15J3C	-20J3C	-25J3C	-35J3C
	Plastic SOJ, 400 mil	-15J4C	-20J4C	-25J4C	-35J4C
Industrial	Plastic SOJ, 300 mil	-15J3I	-20J3I	-25J3I	-35J3I
	Plastic SOJ, 400 mil	-15J4I	-20J4I	-25J4I	-35J4I
Military Temperature	Ceramic DIP, 400 mil	N/A	-20CM	-25CM	-35CM
	28-Pin Ceramic LCC	N/A	-20L28M	-25L28M	-35L28M
	32-Pin Ceramic LCC	N/A	-20L32M	-25L32M	-35L32M
Military Processed*	Ceramic DIP, 400 mil	N/A	-20CMB	-25CMB	-35CMB
	28-Pin Ceramic LCC	N/A	-20L28MB	-25L28MB	-35L28MB
	32-Pin Ceramic LCC	N/A	-20L32MB	-25L32MB	-35L32MB

\* Military temperature range with MIL-STD-883, Class B compliance

N/A = Not Available

Pkg #	<b>J5</b>	
# Pins	28 (300 mil)	
Symbol	Min	Max
A	0.120	0.148
A1	0.078	-
b	0.014	0.020
C	0.007	0.011
D	0.700	0.730
e	0.050 BSC	
E	0.335 BSC	
E1	0.292	0.300
E2	0.267 BSC	
Q	0.025	-

**SOJ SMALL OUTLINE IC PACKAGE**

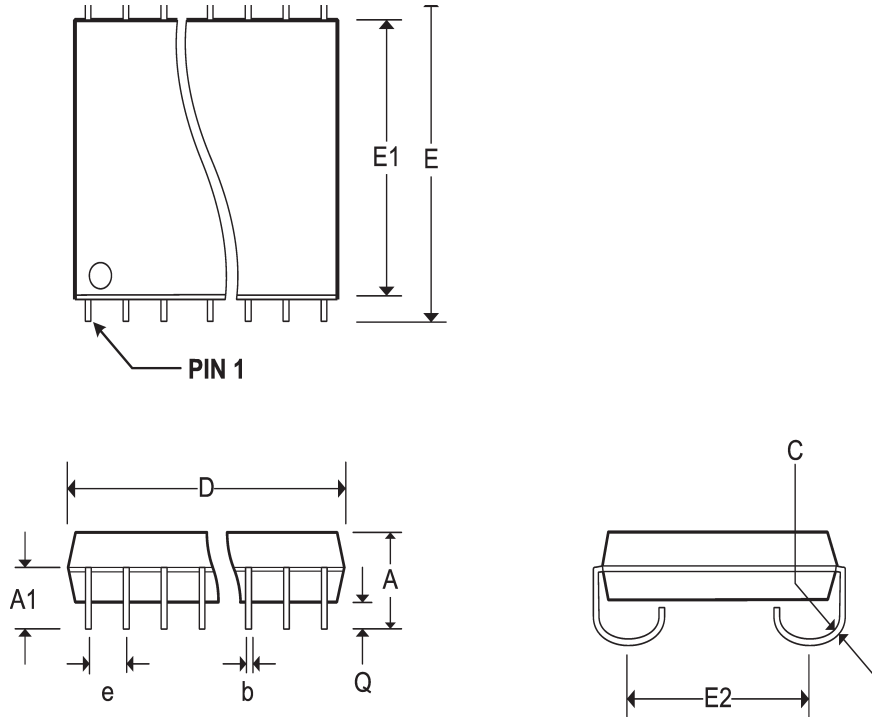

Pkg #	<b>J7</b>	
# Pins	28 (400 mil)	
Symbol	Min	Max
A	0.128	0.148
A1	0.082	-
b	0.013	0.019
C	0.007	0.013
D	0.720	0.730
e	0.050 BSC	
E	0.435	0.445
E1	0.395	0.405
E2	0.360	0.380
Q	0.025	-

**SOJ SMALL OUTLINE IC PACKAGE**

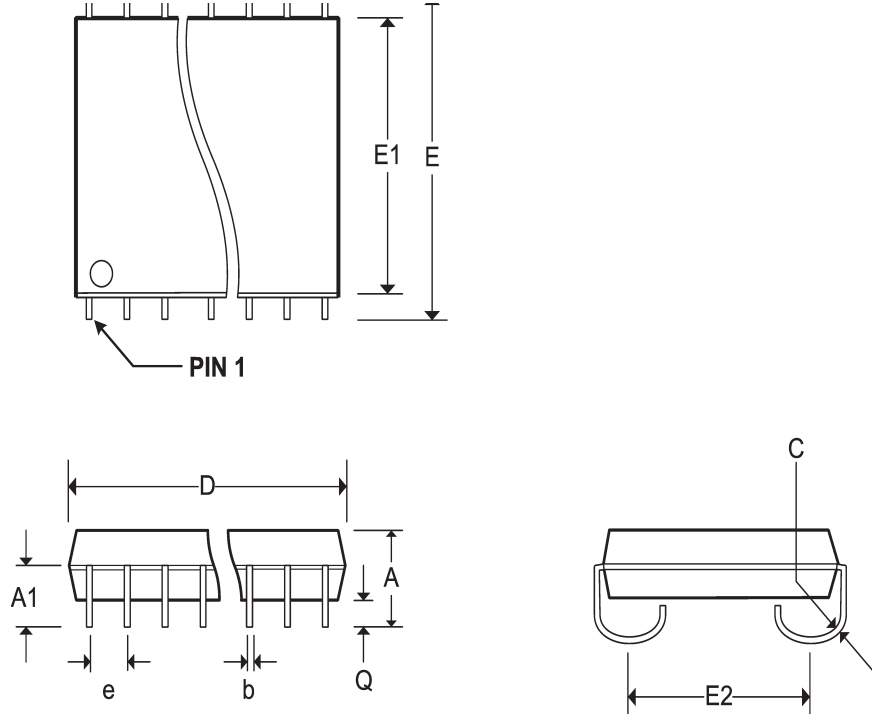



Pkg #	<b>C7</b>	
# Pins	28 (400 mil)	
Symbol	<b>Min</b>	<b>Max</b>
A	0.115	0.255
b	0.016	0.020
b2	0.045	0.065
C	0.008	0.018
D	1.384	1.416
E	0.387	0.403
eA	0.400 BSC	
e	0.100 TYP	
L	0.125	0.200
Q	0.015	0.070
S1	0.005	—
S2	0.005	—

**SIDEBRAZED DUAL IN-LINE PACKAGE**

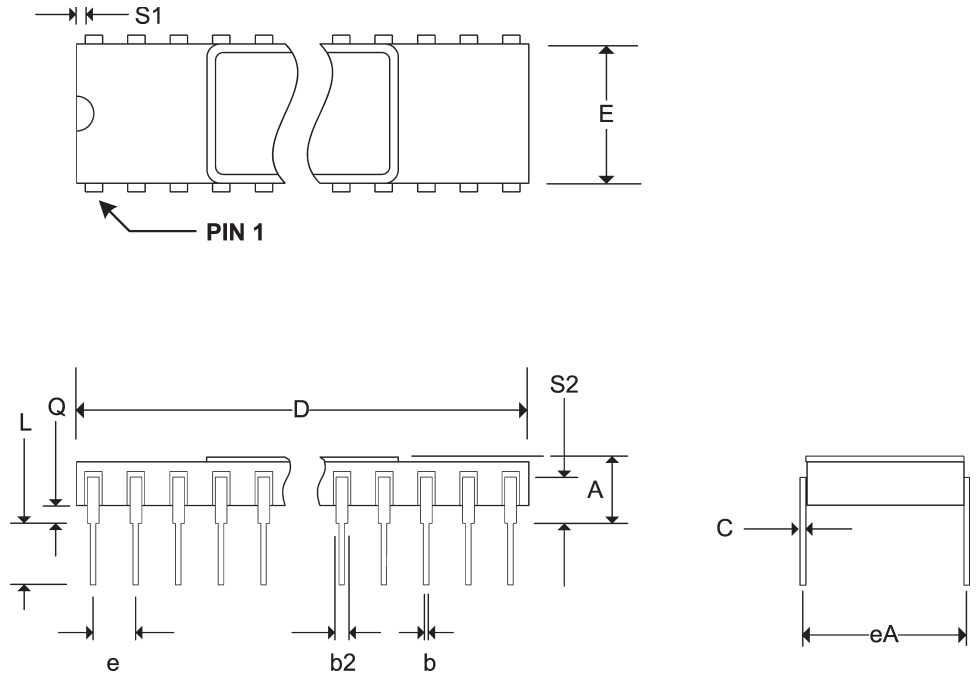

Pkg #	<b>L13</b>	
# Pins	32	
Symbol	<b>Min</b>	<b>Max</b>
A	0.070	0.093
A1	0.054	0.066
B1	0.025	0.031
D	0.442	0.458
D1	0.300 BSC	
D2	0.150 BSC	
D3	—	0.458
E	0.742	0.758
E1	0.400 BSC	
E2	0.200 BSC	
e	0.050 TYP	
h		
j		
L	0.045	0.055
L1	0.045	0.055
L2	0.090 REF	
ND	7	
NE	9	

**RECTANGULAR LEADLESS CHIP CARRIER**

