

### DESCRIPTIONS

The IP4001S is a monolithic integrated circuit, and suitable for 5-ch motor driver which drives focus actuator, tracking actuator, sled motor, spindle motor and tray motor of CDP & V-CD system. Each channel excluding the tray channel driver is a fixed gain driver

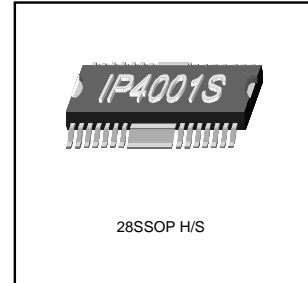

### FEATURES

- Logic controlled 1-CH DC motor driver
- 4-CH BTL(Balanced Transformerless) drivers
- Built-in TSD (Thermal shutdown) circuit
- Built-in 5V regulator with an internal NPN TR
- Built-in mute circuit
- Built-in tray motor speed control circuit
- Wide operating supply voltage range: 6.5V~13.2V

### ORDER INFORMATION

Device	Order Coder	Package	Packing
IP4001S	IP4001S	28SSOPH-375B	Tube
	IP4001S-TF		T&R
	IP4001SL		Tube, Lead Free
	IP4001SL-TF		T&R, Lead Free

### BLOCK DIAGRAM

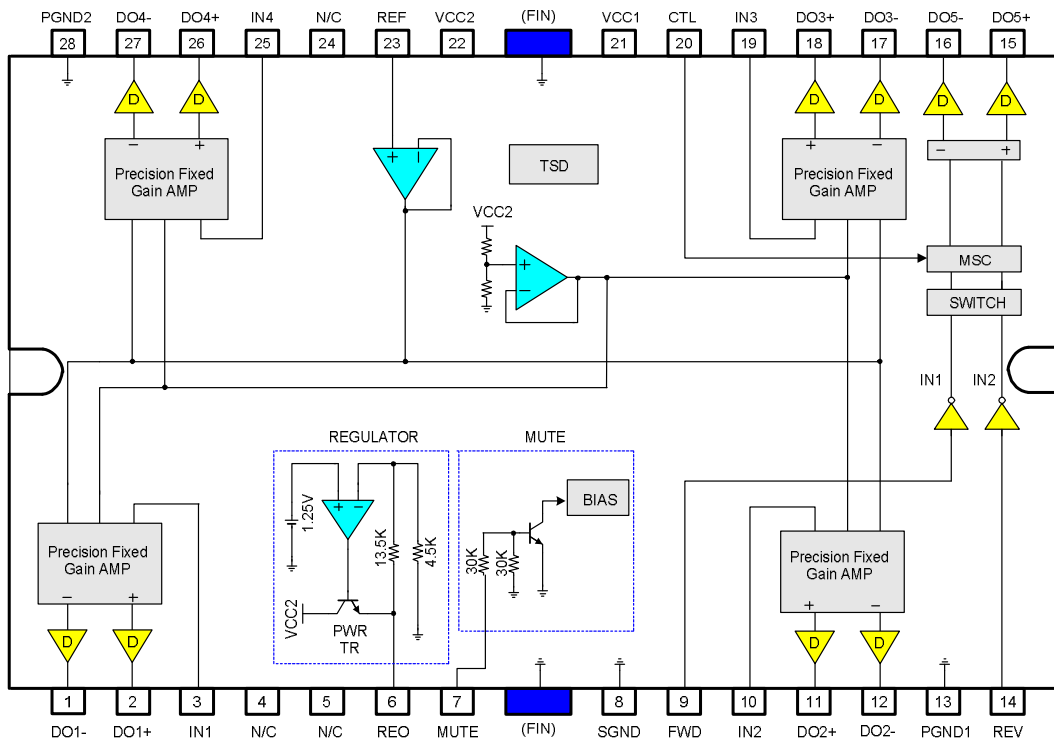

**PIN CONNECTIONS**

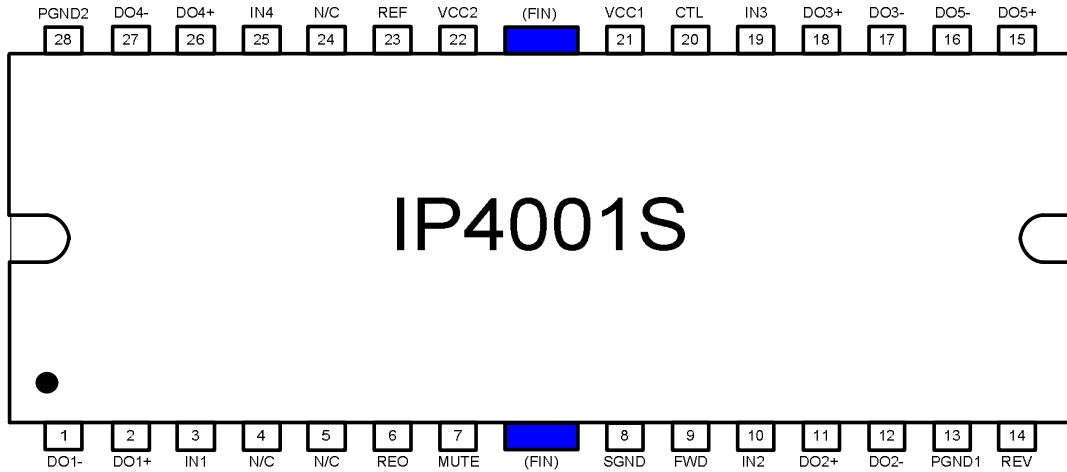

**PIN DESCRIPTIONS**

NO	SYMBOL	I/O	DESCRIPTION	NO	SYMBOL	I/O	DESCRIPTION
1	DO1-	O	CH1 OUTPUT (-)	15	DO5+	O	CH5 OUTPUT (+)
2	DO1+	O	CH1 OUTPUT (+)	16	DO5-	O	CH5 OUTPUT (-)
3	IN1	I	CH1 INPUT	17	DO3-	O	CH3 OUTPUT (-)
4	N/C	-	NO CONNECTION	18	DO3+	O	CH3 OUTPUT (+)
5	N/C	-	NO CONNECTION	19	IN3	I	CH3 INPUT
6	REG	O	REGULATOR OUTPUT	20	CTL	I	CH5 MOTOR SPEED CONTROL INPUT
7	MUTE	I	MUTE INPUT	21	VCC1	-	SUPPLY VOLTAGE 1 (CH2,CH3,CH5)
8	SGND	-	SIGNAL GROUND	22	VCC2	-	SUPPLY VOLTAGE 2 (CH1,CH4,SIGNAL,REG)
9	FWD	I	CH5 INPUT 1	23	REF	I	REFERENCE INPUT
10	IN2	I	CH2 INPUT	24	N/C	-	NO CONNECTION
11	DO2+	O	CH2 OUTPUT (+)	25	IN4	I	CH4 INPUT
12	DO2-	O	CH2 OUTPUT (-)	26	DO4+	O	CH4 OUTPUT (+)
13	PGND1	-	POWER GROUND 1	27	DO4-	O	CH4 OUTPUT (-)
14	REV	I	CH5 INPUT 2	28	PGND2	-	POWER GROUND 2

**ABSOLUTE MAXIMUM RATINGS**

CHARACTERISTICS	SYMBOL	VALUE	UNIT
Maximum supply voltage	Vccmax	18	V
Power dissipation	Pd	2.3 *	W
Operating temperature	Topr	-35 ~ +85	°C
Storage temperature	Tstg	-55 ~ 150	°C
Maximum output current	Iomax	1	A

Note>

1. When mounted on 50mm X 50mm X 1mm PCB (Phenolic resin material).
2. Power dissipation reduces 18.4 mW/°C for using above Ta=25°C
3. Do not exceed Pd and SOA.

**POWER DISSIPATION CURVE**

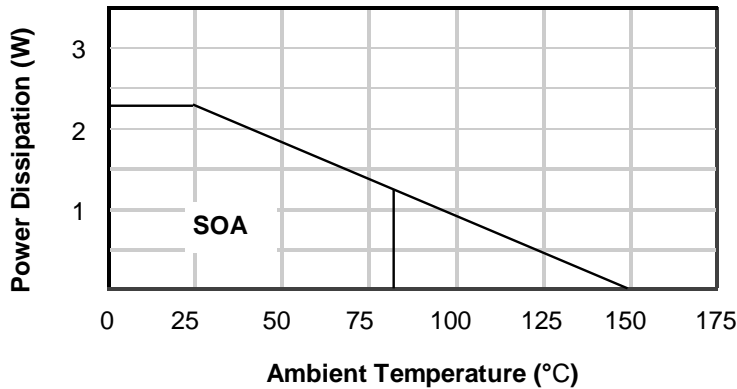

**RECOMMENDED OPERATING CONDITIONS**

CHARACTERISTICS	SYMBOL	VALUE	UNIT
Supply voltage 1	VCC1	*6.5 ~ 13.2	V
Supply voltage 2	VCC2	*6.5 ~ 13.2	V

\* IF you don't use regulator, then the recommended operating voltage is 4.5V ~ 13.2V

**ELECTRICAL CHARACTERISTICS**

(Ta = 25°C, VCC1=VCC2=8V, RL=8ohm, unless otherwise specified.)

CHARACTERISTICS	SYMBOL	CONDITIONS	MIN	TYP	MAX	UNIT
Quiescent circuit current	Icc	RL=open	-	5.5	-	mA
Mute on current	Imute	Pin7=GND	-	2.5	5	mA
Mute on voltage	Vmon	-	-	-	0.5	V
Mute off voltage	Vmoff	-	2	-	-	V
<b>[ BTL DRIVE PART ]</b>						
Output offset voltage	Voo	Vin=2.5V	-80	-	+80	mV
Maximum output voltage	Vom1	Actuator Part (CH1 and CH4)	3.5	4.5	-	V
	Vom2	Spindle and Sled Part (CH2 and CH3)	3.7	4.7	-	
Closed-loop voltage gain	Avf	Vin=0.1Vrms, f=1Khz	5	6.5	8	dB
Ripple rejection ratio	RR	Vin=0.1Vrms, f=120Hz	40	60	-	dB
Slew rate	SR	Vout=4Vp-p, square	-	1.5	-	V/us
<b>[ REGULATOR PART ]</b>						
Output voltage	Vreg	IL=100mA	4.7	5	5.3	V
Load regulation	$\Delta V_{rl}$	IL=0~100mA	-	20	-	mV
Line regulation	$\Delta V_{cc}$	VCC=8V~13.2V, IL=100mA	-	60	-	mV
<b>[ TRAY DRIVE PART ]</b>						
Input high level voltage	Vih	-	2.5	-	-	V
Input low level voltage	Vil	-	-	-	0.5	V
Output voltage	Vo	VCC=8V, RL=45ohm, Pin20=open	2.4	3.1	3.8	V
CTL-to-Output Transfer Gain	Gv	Vcc=8V, RL=45ohm, CTL=3.5V ~ 4.5V	0.6	1	1.4	V
Output offset voltage 1	Voo1	Pin9=Pin14=5V	-50	-	+50	mV
Output offset voltage 2	Voo2	Pin9=Pin14=0V	-50	-	+50	mV

**APPLICATION SUMMARY**

**- All mute function using the REF pin**

When the all mute function is required, you can use the reference pin as follows;

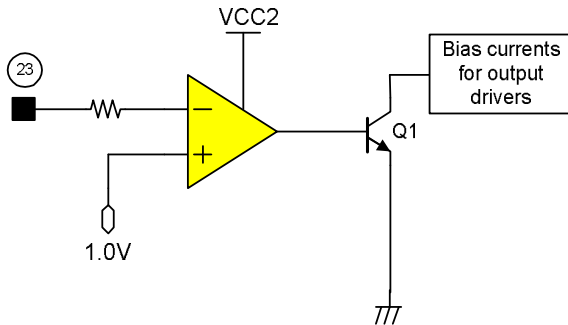

Fig. 1. All mute function using the reference pin

Pin 23	Mute
Above 1.0V	off
Below 1.0V	on

Muting all channel drivers can be obtained using the REF (signal reference) pin. The simplified schematic diagram for reference all mute function is shown in Fig.1. When the input voltage of the signal reference pin (pin23) is below 1.0V, the comparator turns Q1 on and the bias currents of all output drivers are shut down.

**- All mute function using the Mute pin**

All mute function can be also obtained using the MUTE pin as follows;

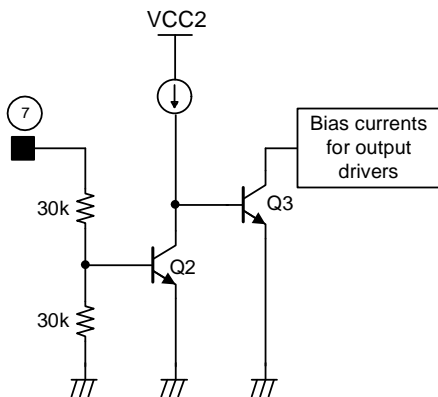

Fig. 2. All mute function using the MUTE pin

Pin 7	Mute
High	off
Low	on

As we can see in Fig. 2, if the voltage of the pin7 becomes low (below 0.5V) or open, the bias currents for all output drivers are shut down. On the contrary, when the voltage of the pin7 becomes high (above 2.0V), the drivers operate normally.

**- Thermal shutdown**

The IP4001S has a thermal protection against the abnormal operation. When the junction temperature rises above 175°C, and channel drivers are muted. This makes the junction temperature be continuously decreased. When the junction temperature falls below 150°C, all channel operate again.

Temperature	mute
Above 175 °C	on
Falls below 150 °C	off

Hysteresis	25 °C
------------	-------

**APPLICATION SUMMARY (Continued)**

**- Tray motor drive part**

CH5 is a forward/reverse controlled DC motor driver for tray motor. The forward or reverse movement of the tray motor is controlled by the pins 9 and 14. The output voltage status according to the control input conditions are shown in the table. The magnitude of the differential output voltage is determined by the control current generator. The control input voltage, VCTL at the pin20 approximately appears across R1 and hence the control current,  $\Delta i$  is  $V_{CTL}/R1$ . This current enters into the control current distributor, which generates two output currents,  $\Delta i1$  and  $\Delta i2$ . The magnitude of  $\Delta i1$  and  $\Delta i2$  are equal each other and is the same as  $\Delta i$ . When the pin9 is high and the pin14 is low, the direction of the current flow of  $\Delta i1$  and  $\Delta i2$  are the same direction as shown in Fig. 5. On the contrary, when the pin9 is low and the pin14 is high, the direction of  $\Delta i1$  and  $\Delta i2$  are reversed. If both the pins 9 and 14 are high or low at the same time,  $\Delta i1$  and  $\Delta i2$  become to be zero and the tray motor is in the brake mode. When the output is not in the brake mode, the magnitude of the differential output voltage and the CTL-to-output transfer gain are given as in the following equations. The resistors, R1 and R2 are selected such that Gv has a typical value of 1.0 V/V. Rb1 and Rb2 are used for setting the output voltage when the pin20 is open circuited. The typical output voltage as the pin20 is opened is about 3.1V for the supply voltage of 8V.

$$V_o = 2 \cdot \frac{R_2}{R_1} \cdot CTL$$

$$G_v = \frac{\partial V_o}{\partial CTL} = 2 \cdot \frac{R_2}{R_1}$$

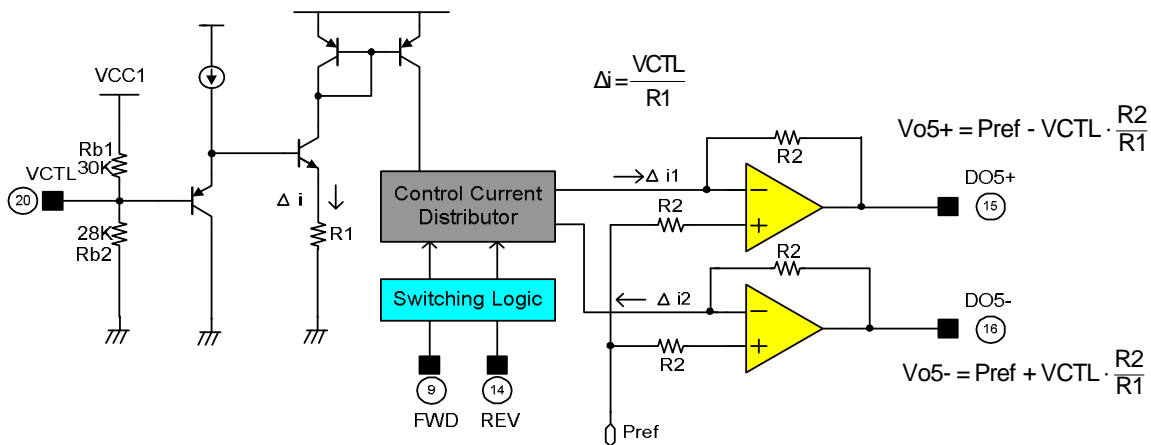

Fig. 3. Tray drive part

INPUT		OUTPUT		
FWD(PIN9)	REV(PIN14)	DO5+(PIN15)	DO5-(PIN16)	STATUS
High	High	Vpref	Vpref	Brake
High	Low	High	Low	Forward
Low	High	Low	High	Reverse
Low	Low	Vpref	Vpref	Brake

**APPLICATION SUMMARY (Continued)**

**- Regulator part**

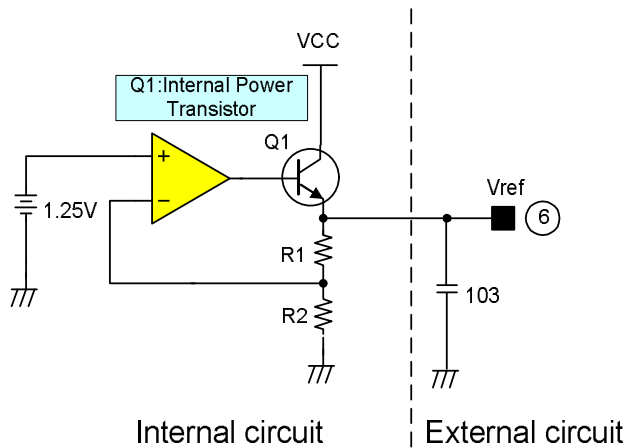
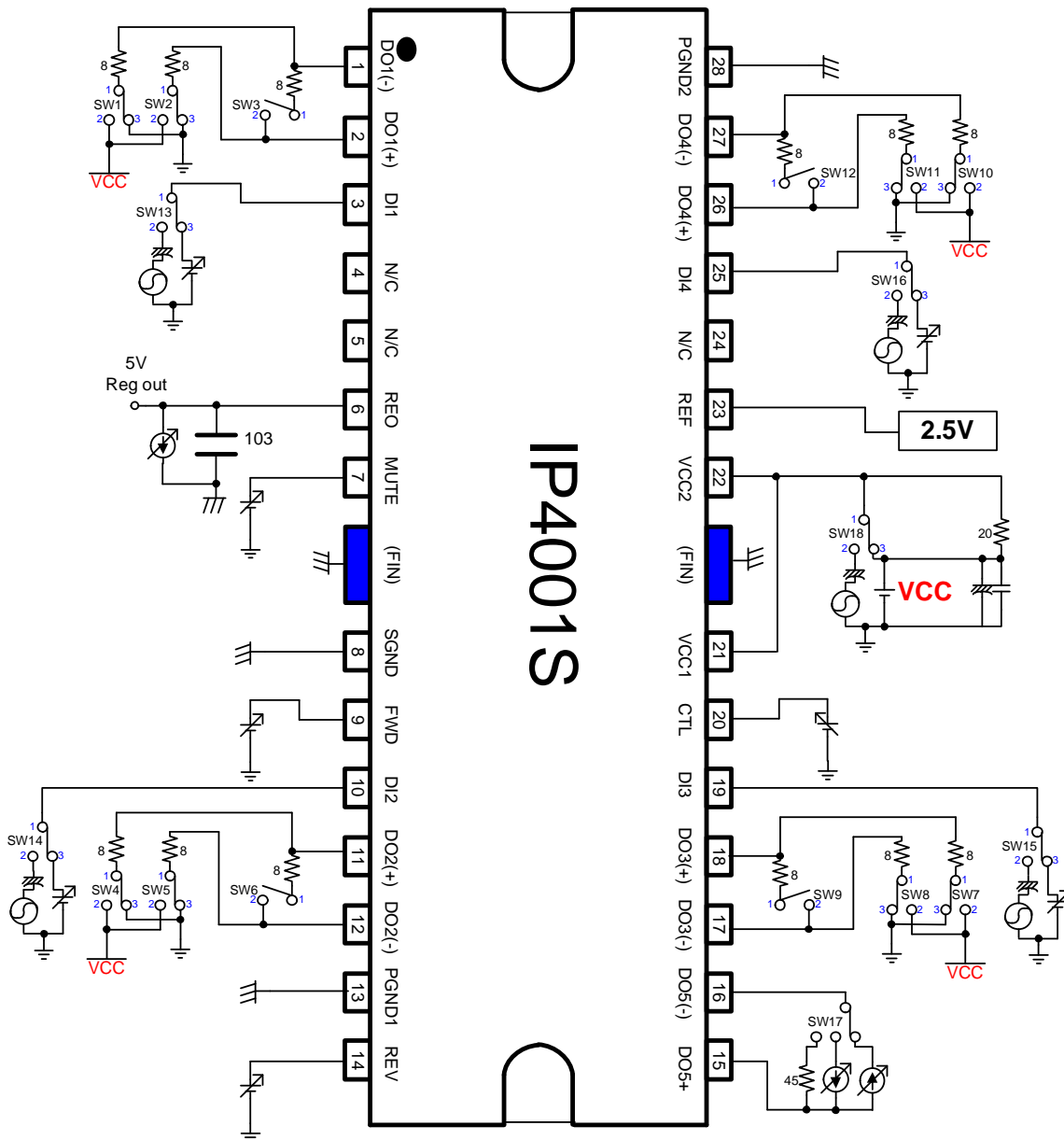

Fig. 4. Regulator

As we can see in Fig. 4, the power transistor of the regulator is internally provided in IP4001S, thus the external power transistor is not needed. Since the regulator output (typical 5V) is provided by the npn transistor, the relatively small capacitor (e.g. 103) is sufficient for eliminating the output ripple or noise voltages.

**TEST CIRCUIT**





**TYPICAL APPLICATION CIRCUIT**

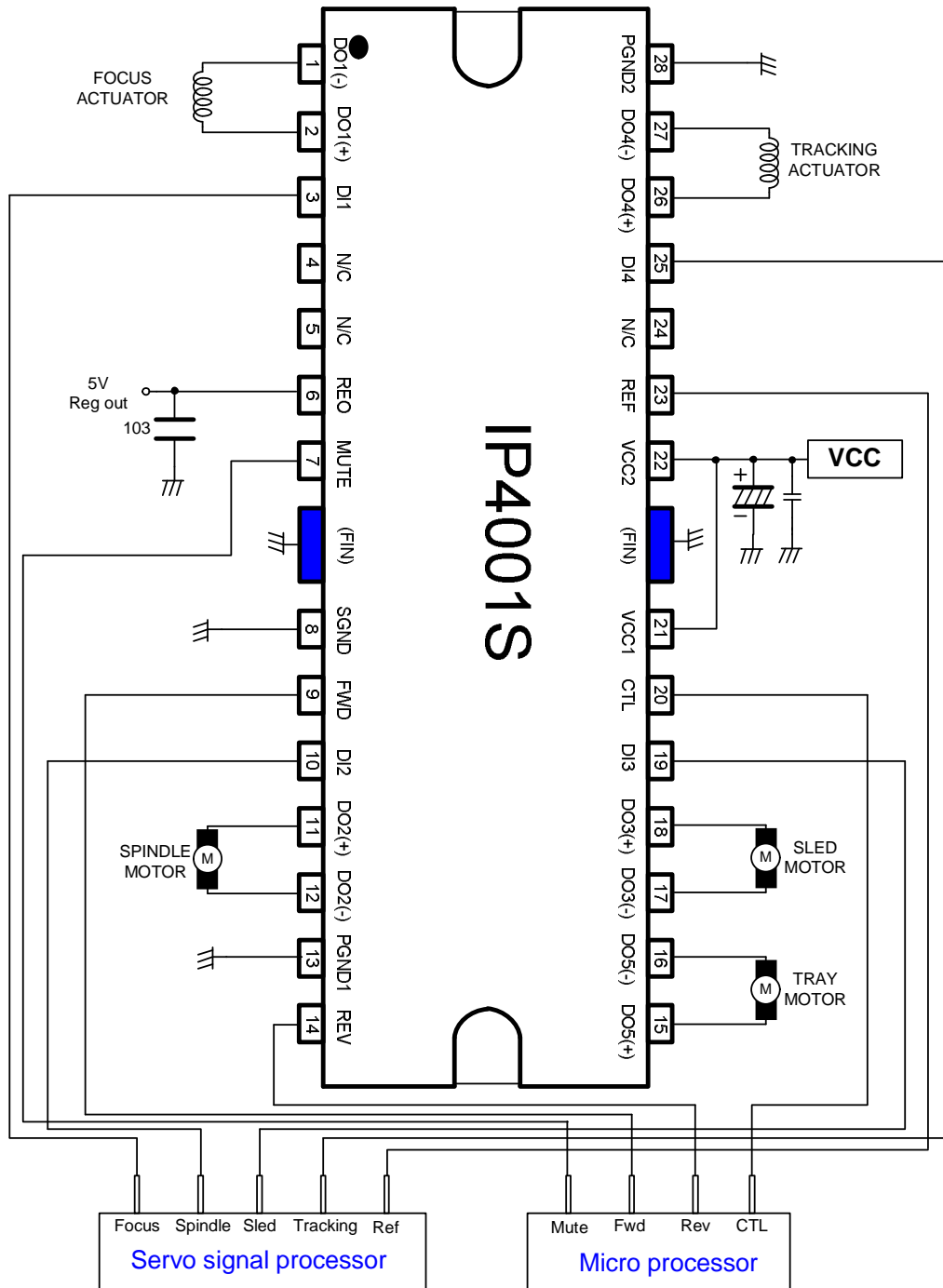

\* Because of the slight difference of the drive capability between CH1/CH4 and CH2/CH3, we recommend that CH1/CH4 should be used as actuator driver and CH2/CH3 as motor driver.

**ELECTRICAL CHARACTERISTICS CURVES**

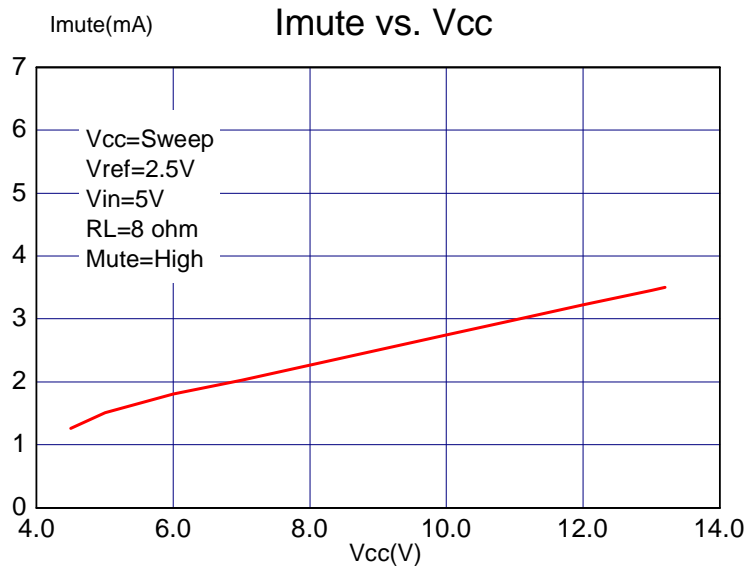
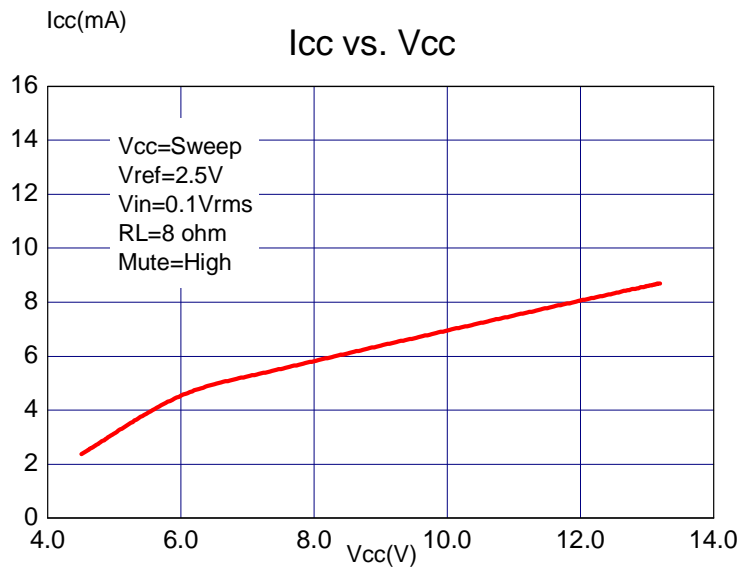

ELECTRICAL CHARACTERISTICS CURVES (Continued)

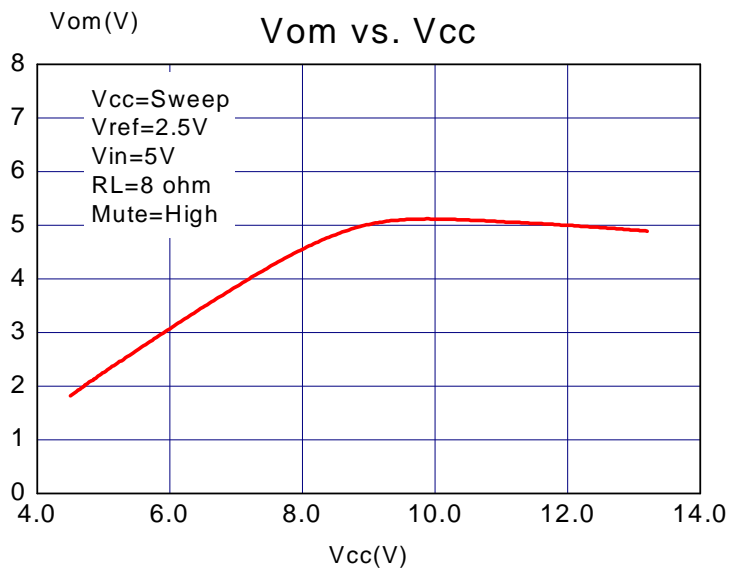
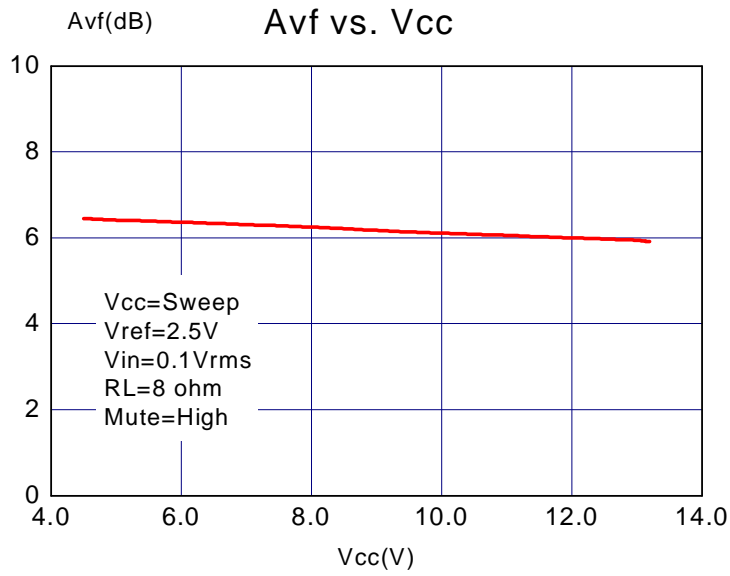

ELECTRICAL CHARACTERISTICS CURVES (Continued)

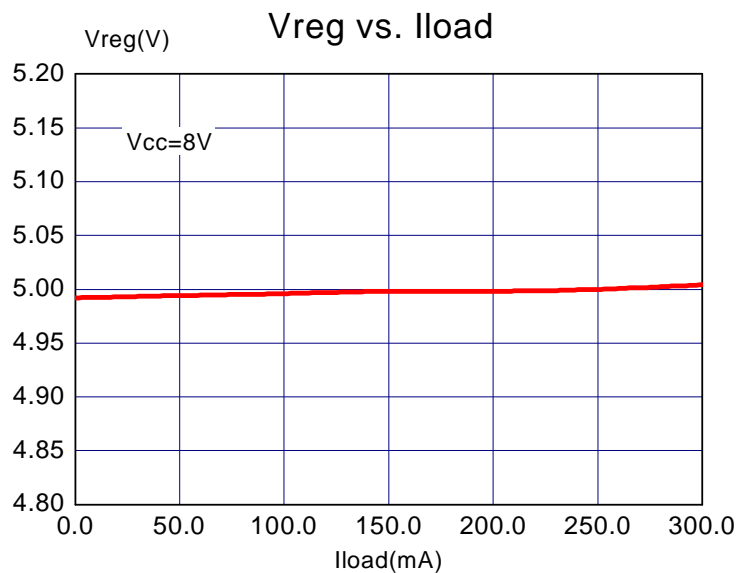
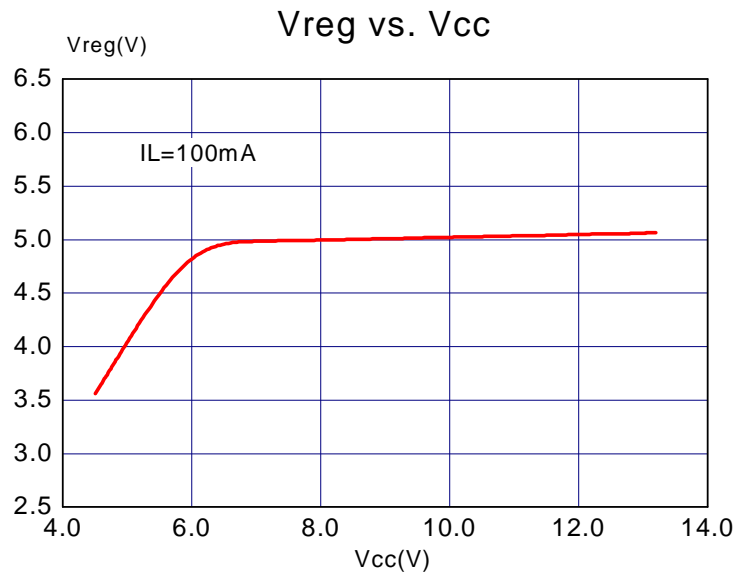

**ELECTRICAL CHARACTERISTICS CURVES (Continued)**

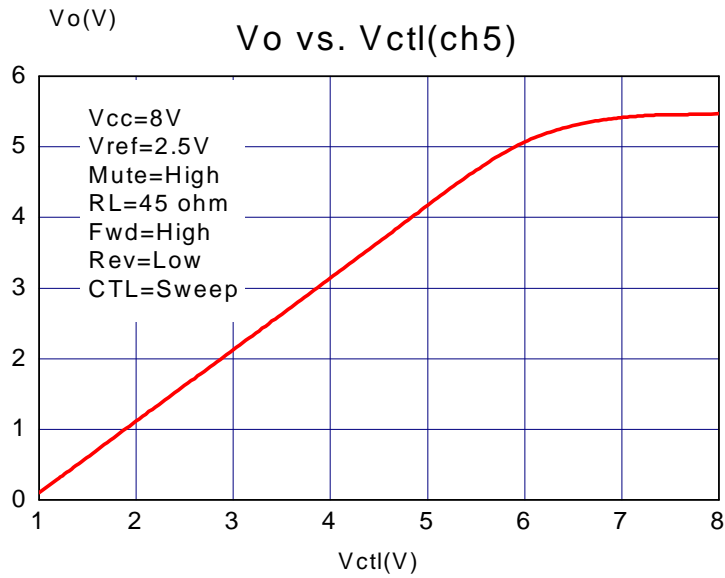
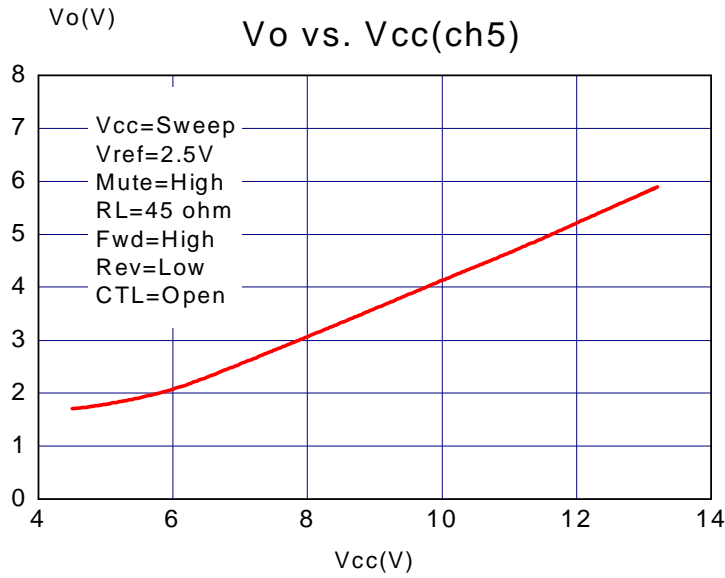

ELECTRICAL CHARACTERISTICS CURVES (Continued)

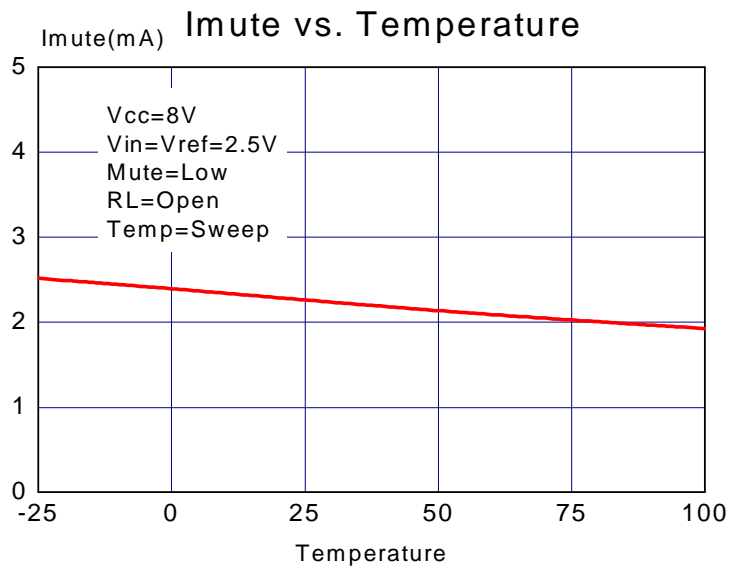
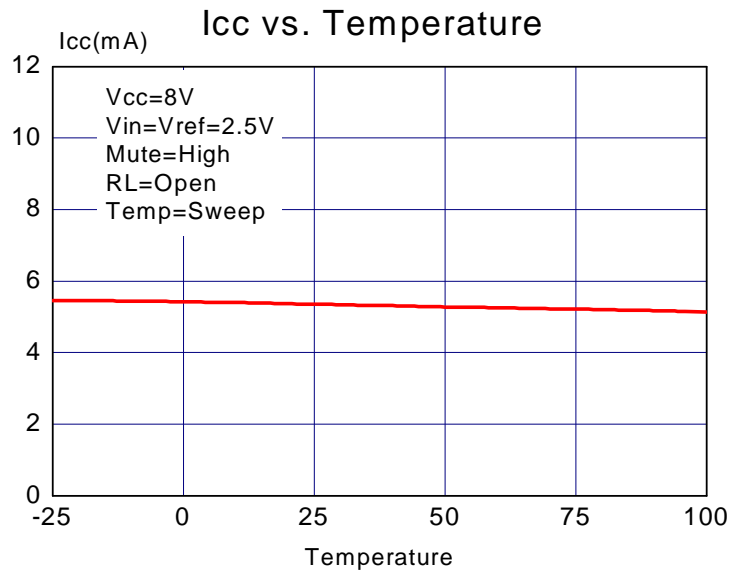

**ELECTRICAL CHARACTERISTICS CURVES (Continued)**

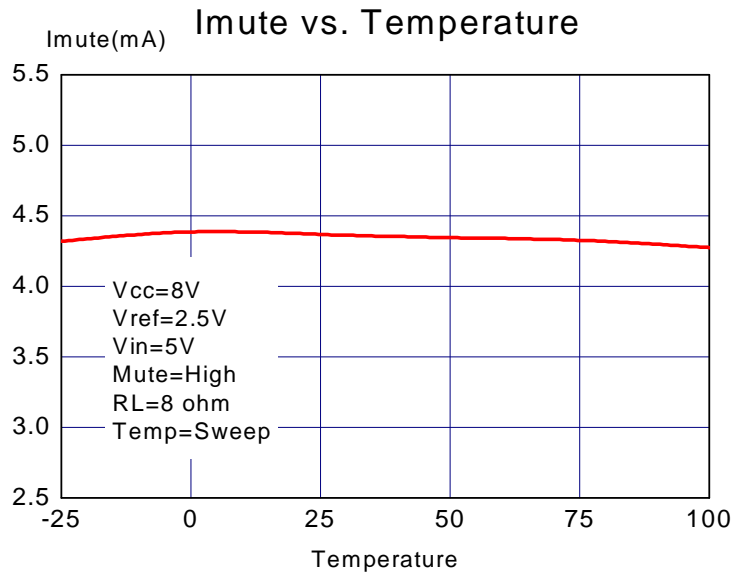
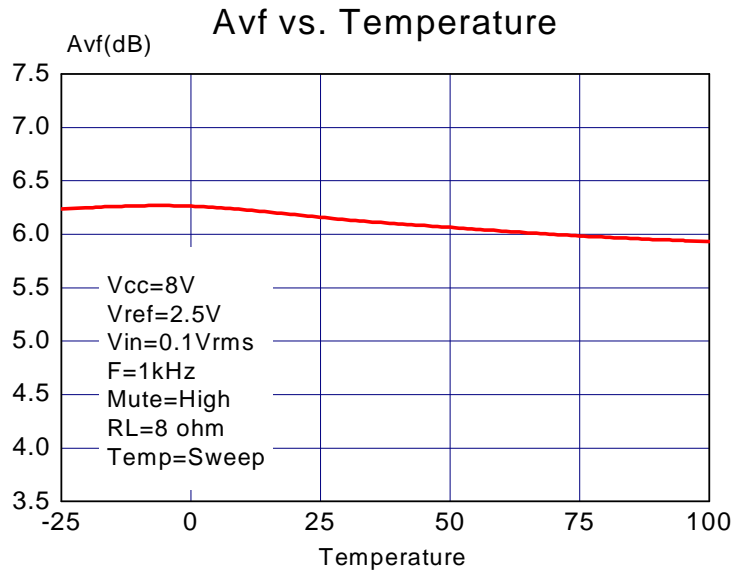

**ELECTRICAL CHARACTERISTICS CURVES (Continued)**

