



CA Series • Common Mode Toroidal Chokes

CA Series common mode toroidal chokes provide an efficient means of filtering supply lines having in-phase signals of equal amplitude thus allowing equipment to meet stringent electrical radiation specifications. Wide frequency ranges can be filtered by using high and low inductance Common Mode toroids in series. Differential mode signals can be attenuated substantially when used together with input and output capacitors.

Features

- Separated windings for minimum capacitance
- Meets requirements of EN138100, VDE 0565, part2: 1997-03 and UL1283
- Competitive pricing due to high volume production
- Manufactured in ISO-9001:2000, TS-16949:2002 and ISO-14001:2004 certified Talema facility
- Fully RoHS compliant



Electrical Specifications @ 25°C

Test frequency: Inductance measured at 0.10VAC @ 10kHz

Test voltage between windings: 1,500 VAC for 60 seconds

Operating temperature: -40°C to +125°C

Climatic category: IEC68-1 40/125/56

Part Number	I _{dc} Amp	L _o (mH) ±30% (2x)	DCR mOhm (2x)	Coil Size O.D. x Ht. (Nominal)	Mtg. Style Size		
					B	V / X	F
CA_-0.4-100	0.4	100	2,807	18 x 7	3	3	3
CA_-0.5-100	0.5	100	2,044	23 x 11	5	4	4
CA_-0.6-100	0.6	100	1,543	29 x 13	5	4A	6
CA_-1.4-100	1.4	100	484	35 x 16	8	9	9
CA_-0.4-82	0.4	82	1,167	15 x 8	3	3	3
CA_-0.5-82	0.5	82	1,851	23 x 11	5	4	4
CA_-0.6-82	0.6	82	1,397	29 x 13	5	4A	6
CA_-1.6-82	1.6	82	350	35 x 16	8	9	9
CA_-0.3-68	0.3	68	3,692	15 x 8	3	2	2
CA_-0.5-68	0.5	68	1,853	18 x 7	3	3	3
CA_-0.6-68	0.6	68	1,353	23 x 11	5	4	4
CA_-0.7-68	0.7	68	1,108	29 x 13	5	4A	6
CA_-1.8-68	1.8	68	277	35 x 16	8	9	9
CA_-0.3-56	0.3	56	3,126	14 x 8	3	2	2
CA_-0.5-56	0.5	56	1,518	18 x 7	3	3	3
CA_-0.6-56	0.6	56	1,378	23 x 11	5	4	4
CA_-0.8-56	0.8	56	807	29 x 13	5	4A	6
CA_-2.0-56	2.0	56	228	35 x 16	8	9	9
CA_-0.4-47	0.4	47	1,942	14 x 8	3	2	2
CA_-0.5-47	0.5	47	1,390	18 x 7	3	3	3
CA_-0.6-47	0.6	47	1,001	23 x 11	5	4	4
CA_-0.9-47	0.9	47	658	29 x 13	5	4A	6
CA_-2.2-47	2.2	47	185	35 x 16	8	9	9
CA_-0.4-39	0.4	39	1,769	14 x 8	3	2	2
CA_-0.5-39	0.5	39	1,267	18 x 7	3	3	3
CA_-0.6-39	0.6	39	912	23 x 11	5	4	4
CA_-1.0-39	1.0	39	537	29 x 13	5	4A	6
CA_-2.5-39	2.5	39	150	36 x 17	8	9	9
CA_-0.4-33	0.4	33	1,628	14 x 8	3	2	2
CA_-0.6-33	0.6	33	837	18 x 7	3	3	3
CA_-0.7-33	0.7	33	751	23 x 11	5	4	4
CA_-1.1-33	1.1	33	434	29 x 13	5	5	6
CA_-2.7-33	2.7	33	124	36 x 17	8	9	9

Part Number	I _{dc} Amp	L _o (mH) ±30% (2x)	DCR mOhm (2x)	Coil Size O.D. x Ht. (Nominal)	Mtg. Style Size		
					B	V / X	F
CA_-0.5-27	0.5	27	1,179	14 x 8	3	2	2
CA_-0.8-27	0.8	27	674	18 x 7	3	3	3
CA_-1.0-27	1.0	27	537	23 x 11	5	4	4
CA_-1.4-27	1.4	27	279	30 x 14	5	4A	6
CA_-3.2-27	3.2	27	87	37 x 17	8	9	9
CA_-0.5-22	0.5	22	960	14 x 8	3	2	2
CA_-0.9-22	0.9	22	542	18 x 7	3	3	3
CA_-1.0-22	1.0	22	485	23 x 11	5	4	4
CA_-1.5-22	1.5	22	227	30 x 14	5	4A	6
CA_-3.6-22	3.6	22	70	37 x 17	8	9	9
CA_-0.6-18	0.6	18	868	14 x 8	3	2	2
CA_-1.0-18	1.0	18	439	18 x 7	3	3	3
CA_-1.1-18	1.1	18	388	23 x 11	5	4	4
CA_-1.6-18	1.6	18	205	30 x 14	5	4A	6
CA_-3.9-18	3.9	18	57	36 x 17	8	9	9
CA_-0.6-15	0.6	15	793	14 x 8	3	2	2
CA_-1.0-15	1.0	15	401	18 x 7	3	3	3
CA_-1.2-15	1.2	15	315	23 x 11	5	4	4
CA_-1.8-15	1.8	15	167	30 x 14	5	4A	6
CA_-4.3-15	4.3	15	47	36 x 17	8	9	9
CA_-0.7-12	0.7	12	709	14 x 8	3	2	2
CA_-1.1-12	1.1	12	358	18 x 7	3	3	3
CA_-1.4-12	1.4	12	253	23 x 11	5	4	4
CA_-1.9-12	1.9	12	149	30 x 13	5	4A	6
CA_-4.9-12	4.9	12	37	36 x 17	8	9	9
CA_-0.7-10	0.7	10	647	14 x 8	3	2	2
CA_-1.2-10	1.2	10	285	18 x 7	3	3	3
CA_-1.6-10	1.6	10	203	23 x 11	5	4	4
CA_-2.0-10	2.0	10	136	29 x 13	5	4A	6
CA_-5.0-10	5.0	10	34	36 x 17	8	9	9
CA_-1.1-6.8	1.1	6.8	342	14 x 8	3	2	2
CA_-1.3-6.8	1.3	6.8	235	18 x 7	3	3	3
CA_-2.0-6.8	2.0	6.8	148	23 x 11	5	4	4
CA_-2.6-6.8	2.6	6.8	79	30 x 13	5	4A	6
CA_-5.5-6.8	5.5	6.9	28	35 x 16	8	9	9

THE TALEMA GROUP • Magnetic Components for Universal Applications



CA Series • Common Mode Toroidal Chokes

Part Number	I _{DC} Amp	L _O (mH) ±30% (2x)	DCR mOhm (2x)	Coil Size O.D. x Ht. (Nominal)	Mtg. Style Size			Part Number	I _{DC} Amp	L _O (mH) ±30% (2x)	DCR mOhm (2x)	Coil Size O.D. x Ht. (Nominal)	Mtg. Style Size		
					B	V / X	F						B	V / X	F
CA_-1.2-5.6	1.2	5.6	276	14 x 8	3	2	2	CA_-1.9-1.2	1.9	1.2	71	14 X 8	3	2	2
CA_-1.5-5.6	1.5	5.6	193	18 x 7	3	3	3	CA_-3.1-1.2	3.1	1.2	44	18 X 7	3	3	3
CA_-2.0-5.6	2.0	5.6	120	23 x 11	5	4	4	CA_-5.0-1.2	5.0	1.2	20	23 X 11	5	4	4
CA_-2.8-5.6	2.8	5.6	72	29 x 13	5	4A	6	CA_-7.5-1.2	7.5	1.2	10	30 X 41	5	5	6
CA_-5.9-5.6	5.9	5.6	26	35 x 16	8	9	9	CA_-9.6-1.2	9.6	1.2	10	33 x 14	8	9	9
CA_-1.2-4.7	1.2	4.7	253	14 x 8	3	2	2	CA_-2.0-1.0	2.0	1.0	65	14 X 8	3	2	2
CA_-1.6-4.7	1.6	4.7	110	18 x 7	3	3	3	CA_-3.5-1.0	3.5	1.0	32	18 X 6	3	3	3
CA_-1.9-4.7	1.9	4.7	99	23 x 11	5	4	4	CA_-5.0-1.0	5.0	1.0	18	23 X 11	5	4	4
CA_-3.0-4.7	3.0	4.7	58	29 x 13	5	5	6	CA_-7.8-1.0	7.8	1.0	9	30 X 14	5	5	6
CA_-6.2-4.7	6.2	4.7	23	34 x 15	8	9	9	CA_-10-1.0	10	1.0	9	33 x 14	8	9	9
CA_-1.3-3.9	1.3	3.9	230	14 x 8	3	2	2	CA_-2.8-0.68	2.8	0.68	37	14 X 8	3	2	2
CA_-1.8-3.9	1.8	3.9	100	18 x 7	3	3	3	CA_-4.2-0.68	4.2	0.68	21	18 X 7	3	3	3
CA_-2.1-3.9	2.1	3.9	81	23 x 11	5	4	4	CA_-6.0-0.68	6.0	0.68	13	23 X 11	5	4	4
CA_-3.5-3.9	3.5	3.9	42	30 x 14	5	5	6	CA_-8.5-0.68	8.5	0.68	7	30 X 14	5	4A	6
CA_-6.8-3.9	6.8	3.9	19	34 x 15	8	9	9	CA_-11-0.68	11	0.68	7	33 x 14	8	9	9
CA_-1.5-3.3	1.5	3.3	165	14 x 8	3	2	2	CA_-3.6-0.47	3.6	0.47	28	14 X 8	3	2	2
CA_-2.0-3.3	2.0	3.3	92	18 x 7	3	3	3	CA_-6.0-0.47	6.0	0.47	11	18 X 7	3	3	3
CA_-3.0-3.3	3.0	3.3	52	23 x 11	5	4	4	CA_-7.0-0.47	7.0	0.47	10	23 X 11	5	4	4
CA_-4.0-3.3	4.0	3.3	34	30 x 14	5	5	6	CA_-9.5-0.47	9.5	0.47	6	29 X 13	5	5	6
CA_-7.5-3.3	7.5	3.3	16	34 x 15	8	9	9	CA_-12-0.47	12	0.47	6	32 x 13	8	9	9
CA_-1.5-2.7	1.5	2.7	172	14 x 8	3	2	2	CA_-3.2-0.33	3.2	0.33	17	14 X 8	3	2	2
CA_-2.2-2.7	2.2	2.7	83	18 x 7	3	3	3	CA_-6.1-0.33	6.1	0.33	7	18 X 6	3	3	3
CA_-3.5-2.7	3.5	2.7	47	23 x 11	5	4	4	CA_-7.2-0.33	7.2	0.33	7	23 X 11	5	4	4
CA_-4.8-2.7	4.8	2.7	22	30 x 14	5	5	6	CA_-10-0.33	10	0.33	5	29 X 13	5	4A	6
CA_-7.8-2.7	7.8	2.7	14	34 x 15	8	9	9	CA_-13-0.33	13	0.33	5	32 x 13	8	9	9
CA_-1.6-2.2	1.6	2.2	135	14 x 7	3	2	2	CA_-3.7-0.22	3.7	0.22	12	14 X 8	3	2	2
CA_-2.3-2.2	2.3	2.2	75	18 x 7	3	3	3	CA_-7.6-0.22	7.6	0.22	5	18 X 7	3	3	3
CA_-4.0-2.2	4.0	2.2	30	23 x 11	5	4	4	CA_-8.9-0.22	8.9	0.22	4	23 X 11	5	4	4
CA_-5.8-2.2	5.8	2.2	16	31 x 15	5	5	6	CA_-11-0.22	11	0.22	4	29 X 12	5	5	6
CA_-8.2-2.2	8.2	2.2	13	34 x 15	8	9	9	CA_-13-0.22	13	0.22	4	32 x 13	8	9	9
CA_-1.6-1.8	1.6	1.8	111	14 x 8	3	2	2	CA_-4.6-0.15	4.6	0.15	8	14 X 8	3	2	2
CA_-2.5-1.8	2.5	1.8	60	18 x 7	3	3	3	CA_-9.3-0.15	9.3	0.15	3	18 X 7	3	3	3
CA_-4.5-1.8	4.5	1.8	27	23 x 11	5	4	4	CA_-10-0.15	10	0.15	3	23 X 11	5	4	4
CA_-6.0-1.8	6.0	1.8	14	30 x 14	5	5	6	CA_-12-0.15	12	0.15	3	29 X 12	5	5	6
CA_-8.7-1.8	8.7	1.8	12	34 x 15	8	9	9	CA_-16-0.15	16	0.15	3	32 x 13	8	9	9
CA_-1.8-1.5	1.8	1.5	89	14 X 8	3	2	2	CA_-5.7-0.10	5.7	0.10	5	14 X 8	3	2	2
CA_-2.8-1.5	2.8	1.5	49	18 X 7	3	3	3	CA_-10-0.10	10	0.10	2	18 X 7	3	3	3
CA_-5.0-1.5	5.0	1.5	22	23 X 11	5	4	4	CA_-12-0.10	12	0.10	2	22 X 11	5	4	4
CA_-7.0-1.5	7.0	1.5	11	31 X 15	5	5	6	CA_-13-0.10	13	0.10	3	28 X 12	5	5	6
CA_-9.1-1.5	9.1	1.5	11	33 x 14	8	9	9	CA_-17-0.10	17	0.10	3	32 X 13	8	9	9

Talema's Engineering staff can assist in the design of other inductance values and sizes.

Notes:

- Inductance measured at 25°C and 10 kHz.
L < 2mH test level < 2.5mA
L > 2mH test level < 250mV
- Inductance loss <10% by DC preload with I_N (current compensated).
- DC Resistance measured at 25°C ±5°C.
- Test voltage per VDE 0565/2
- 250 VAC Nominal Operating Voltage
- Maximum Ambient Temperature: 60°C

Ordering Key

CA B - 0.5 - 10mH

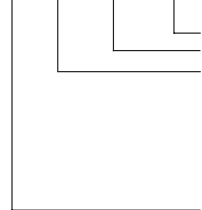

Inductance Value per Winding

Current Rating (Amps)

Mounting Style

O = Open: 'OV' - Vertical & 'OH' - Horizontal Mount

B = Base Mount

V = Vertical Encapsulated - Pins 7 - 2 and 6 - 3

X = Vertical Encapsulated - Pins 8 - 1 and 5 - 4

F = Flat Encapsulated

Basic Series Designation

Mounting Style • CA Series • Common Mode Toroidal Chokes

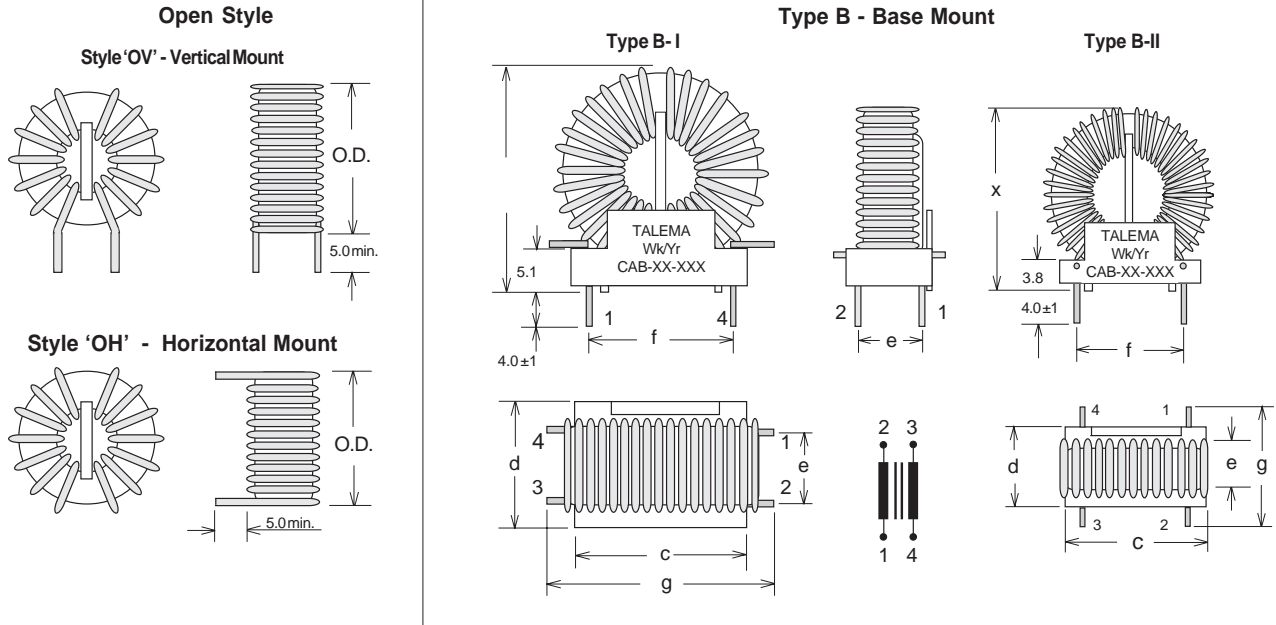

Mounting Style	Size Code	Dimensions Nominal (mm)									
		c	d	e	f	g	h	i	x	Pin Ø	
Base Mount	B- II	3	19.1	10.8	6.4	15.2	15.9	--	--	Coil O.D. + 3.8	1.02
	B- I	5	25.4	16.0	10.2	20.3	34.3	--	--	Coil O.D. + 3.5	1.27
		8	27.9	20.3	15.2	22.9	36.8	--	--		
Vertical Mount	"V"	2	17.8	12.8	20.0	10.0	5.0	15.0	5.0	--	0.60 x 0.88
	Pins	3	23.0	15.5	25.0	12.5	10.0	20.0	5.0	--	0.60 x 0.88
	7-2 & 6-3	4	27.0	18.0	30.0	15.0	12.5	22.5	5.0	--	0.60 x 0.88
	"X"	4A	32.5	18.0	35.0	15.0	12.5	--	--	--	0.60 x 0.88
	Pins	5	32.0	20.5	35.0	17.5	12.5	27.5	7.5	--	0.75 x 1.10
	8-1 & 5-4	9	43.0	28.0	47.5	25.0	25.0	40.0	7.5	--	0.75 x 1.10
Flat Mount	F	2	17.5	17.0	12.5	10.0	15.0	--	--	--	0.60 x 0.88
		3	22.5	22.0	15.0	12.5	20.0	--	--	--	0.60 x 0.88
		4	27.5	27.0	17.5	15.0	25.0	--	--	--	0.60 x 0.88
		6	32.5	32.0	20.0	20.0	30.0	--	--	--	0.60 x 0.88
		9	42.5	42.0	28.5	25.0	35.0	--	--	--	0.60 x 0.88

Germany: Int.+4989-841 00-0 • Ireland: Int.+35 374 - 954 8666 • Czech Rep: Int.+420 377 - 338 351 • India: Int.+91 427 - 244 1325
<http://www.talema-nuotem.com>