

FEATURES

- Pin-compatible with the CL-PD6832
- PC 98 v1.0 and PC 97 compliant
- Supports the *PCI Bus Power Management Interface for PCI to CardBus Bridges* (PCMCIA equivalent of ACPI) including PME# support
- High-performance support for 133-Mbyte-per-second transfers
- ZV (zoomed video) port support for multimedia applications using bypass mode
- Programmable interrupt protocol: External Hardware, PCI/Way, PCI, or PC/PCI interrupt signalling modes
- Up to four multiplexed general-purpose I/O pins
- Seven fully programmable memory or I/O windows per socket
- Programmable per-socket activity indicators
- Bus master capability
- PCI 2.1, PCI 2.2 draft, PC Card Standard (March 1997), ExCA™, and JEIDA 4.2 compliant
- CL-PD672X register set compatible
- Mixed-voltage support
- Support for 5-V and 3.3-V PC Cards

PCI-to-CardBus Host Adapter

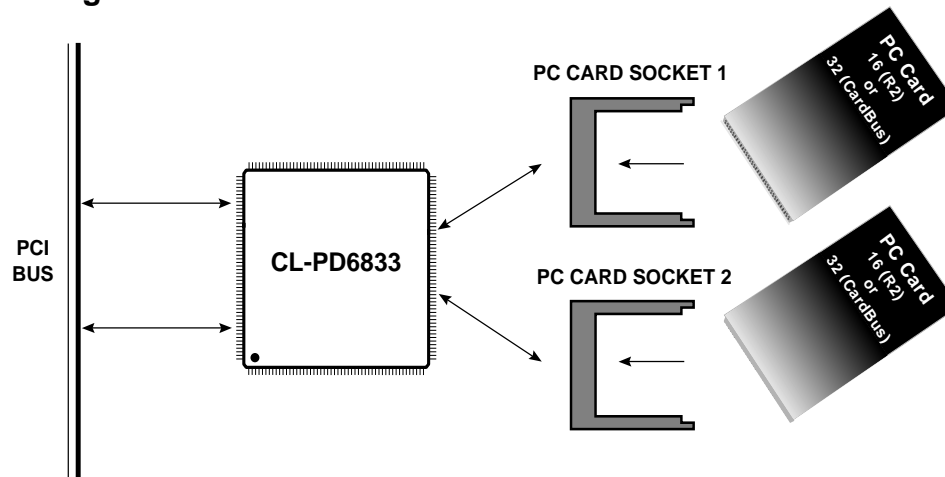
OVERVIEW

The CL-PD6833 easily interfaces with the 8- and 16-bit R2 PC Cards and the 32-bit CardBus PC Cards. It is the third device to be developed in Cirrus Logic's family of CardBus controllers. The CL-PD6833 gives system designers of portable, notebook, and handheld computers the most integrated solution for their needs. Providing high performance, low-power consumption, and a highly compatible and flexible interface, the CL-PD6833 enables easy functionality for PC Card and CardBus applications such as LANs, modems, and multimedia applications.

The CL-PD6833 is a single-chip CardBus controller capable of controlling two independent PC Card and/or CardBus sockets. Featuring enhanced bus traffic management and cycle pipelining technology, the CL-PD6833 supports transactions at the PCI specification limit of 133 Mbytes per second. This significantly improves the performance over previous Cirrus Logic controllers.

(cont.)

System Block Diagram



OVERVIEW (cont.)

The CL-PD6833 is compliant with the latest PC 97 and PC 98 design guidelines. The CL-PD6833 is also compliant with PCI 2.1, PCI 2.2 draft, PC Card Standard (March 1997), ExCA™, and JEIDA 4.2 standards. Like the CL-PD6834, the register set of the CL-PD6833 is a superset of the Intel® 365-SL, the CL-PD672X, and the CL-PD6832 register sets; this ensures full compatibility with existing card and socket services software, thus maximizing PC software compatibility.

The CL-PD6833 is compliant with the *PCI Bus Power Management Interface for PCI to CardBus Bridges*, which is the PCMCIA industry's document for ACPI compatibility. The device is also compliant with the PC Card controller Device Class Specification.

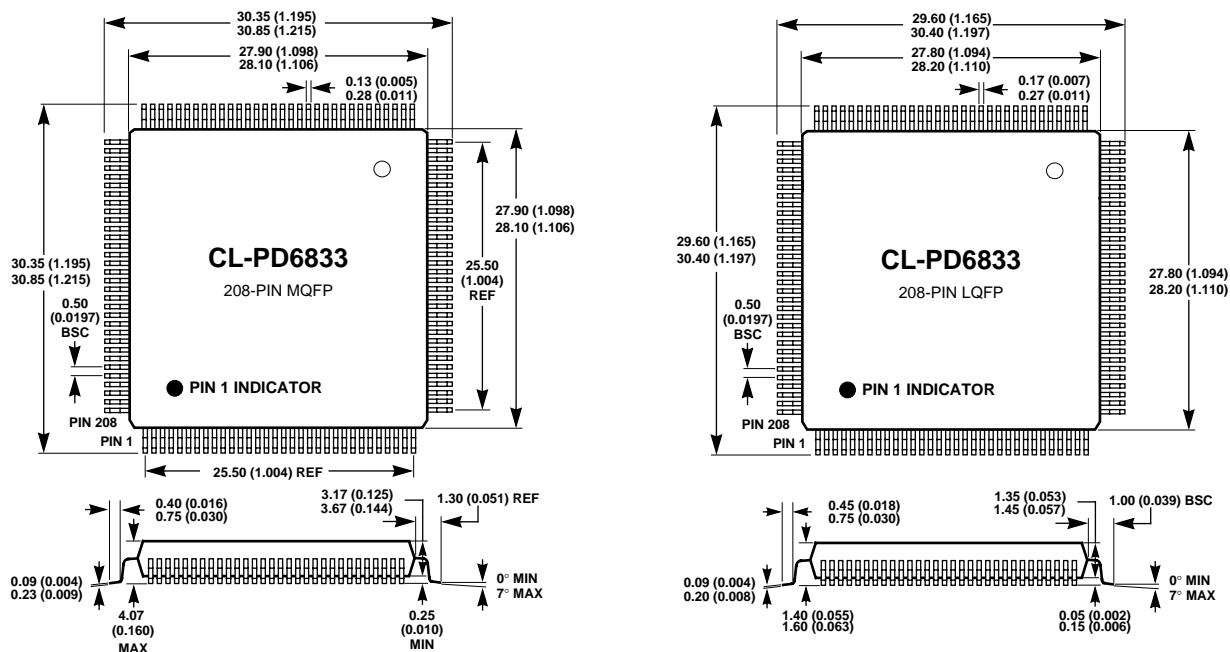
The CL-PD6833 uses state-of-the-art clock control to satisfy industry power consumption targets, thereby assuring minimum power consumption during the various operational and suspend states. The device also offers a Hardware Suspend mode, which is a method of powering down the host controller to the minimum power consumption levels in addition to ACPI-compatible power management features.

The ACPI-compatible power management features of the CL-PD6833 plus its state-of-the-art clock management and hardware suspend modes ensure that the system designer is provided with all the power management control needed to implement an energy-efficient, mixed-voltage CardBus controller.

Zoomed video support had become an important consideration for system designers since 1996. The CL-PD6833 can be programmed to tristate its PC Card interface so that graphics and audio signals from a zoomed video-capable PC Card can be sent to the respective graphics and audio controller zoomed video ports. This solution is practical for multimedia applications such as DVD, full-motion video, and video conferencing.

The CL-PD6833 provides flexibility in non-PC compatible applications by allowing easy translation of PCI bus memory cycles to PC Card 16 I/O cycles for processors with memory cycles only. In addition, the CL-PD6833 has up to four multiplexed GPIO (general-purpose I/O) pins to interface with external devices that the system designer may wish to implement.

Package Outline Drawings



NOTES:

- 1) Dimensions are in millimeters (inches), and controlling dimension is millimeter.
- 2) The drawing above does not reflect exact package pin count.
- 3) Before beginning any new design with this device, please contact Cirrus Logic for the latest package information.

Table of Contents

1. CONVENTIONS	7
2. PIN INFORMATION	9
2.1 Pin Diagrams	10
2.2 Pin Description Conventions	12
2.3 Pin Descriptions	13
3. INTRODUCTION TO THE CL-PD6833	25
3.1 System Architecture	25
3.1.1 PC Card Basics	25
3.1.2 CL-PD6833 R2 Windowing Capabilities	26
3.1.3 Zoomed Video Port	29
3.1.4 Interrupts	30
3.1.5 PCI/Way DMA	34
3.1.6 Power Management	34
3.1.7 Socket Power Management Features	35
3.1.8 Bus Sizing	37
3.1.9 Programmable PC Card Timing	37
3.1.10 ATA Mode Operation	37
3.1.11 PC Card Sensing	37
3.2 Upgrading from the CL-PD6832 to the CL-PD6833	38
3.2.1 Added Registers	39
3.3 Host Access to Registers	42
3.4 Power-On Setup	44
4. REGISTER DESCRIPTION CONVENTIONS	45
5. PCI CONFIGURATION REGISTERS	47
5.1 Vendor ID and Device ID	48
5.2 Command and Status	49
5.3 Revision ID and Class Code	52
5.4 Cache Line Size, Latency Timer, Header Type, and BIST	53
5.5 Memory Base Address	54
5.6 CardBus Status	55
5.7 PCI Bus Number, CardBus Number, Subordinate Bus Number, and CardBus Latency Timer	57
5.8 Memory Base 0-1	58
5.9 Memory Limit 0-1	59
5.10 I/O Base 0-1	60
5.11 I/O Limit 0-1	61
5.12 Interrupt Line, Interrupt Pin, and Bridge Control	62
5.13 Subsystem Vendor ID and Subsystem Device ID	65
5.14 PC Card 16-Bit IF Legacy Mode Base Address	66
5.15 Power Management Registers	67
5.16 Power Management Control and Status	68
5.17 DMA Slave Configuration Register	70
5.18 Socket Number	71
5.19 Configuration Miscellaneous 1	73

6.	CARDBUS REGISTERS	75
6.1	Status Event — PME_CXT	75
6.2	Status Mask — PME_CXT	77
6.3	Present State	78
6.4	Event Force	80
6.5	Control — PME_CXT	82
7.	OPERATION REGISTERS	85
7.1	Index	85
7.2	Data	90
8.	DEVICE CONTROL REGISTERS	91
8.1	Chip Revision	91
8.2	Interface Status	92
8.3	Power Control — PME_CXT	94
8.4	Interrupt and General Control — PME_CXT	96
8.5	Card Status Change — PME_CXT	98
8.6	Management Interrupt Configuration — PME_CXT	99
8.7	Mapping Enable	101
9.	WINDOW MAPPING REGISTERS	103
9.1	I/O Window Mapping Registers	105
9.1.1	I/O Window Control	105
9.1.2	System I/O Map 0–1 Start Address Low	107
9.1.3	System I/O Map 0–1 Start Address High	107
9.1.4	System I/O Map 0–1 End Address Low	108
9.1.5	System I/O Map 0–1 End Address High	108
9.1.6	Card I/O Map 0–1 Offset Address Low	109
9.1.7	Card I/O Map 0–1 Offset Address High	109
9.2	Memory Window Mapping Registers	110
9.2.1	System Memory Map 0–4 Start Address Low	110
9.2.2	System Memory Map 0–4 Start Address High	111
9.2.3	System Memory Map 0–4 End Address Low	112
9.2.4	System Memory Map 0–4 End Address High	113
9.2.5	Card Memory Map 0–4 Offset Address Low	114
9.2.6	Card Memory Map 0–4 Offset Address High	115
10.	GENERAL WINDOW MAPPING REGISTERS	117
10.1	General Mapping Registers for I/O Mode	119
10.1.1	Gen Map 0–6 Start Address Low (I/O)	119
10.1.2	Gen Map 0–6 Start Address High (I/O)	120
10.1.3	Gen Map 0–6 End Address Low (I/O)	121
10.1.4	Gen Map 0–6 End Address High (I/O)	122
10.1.5	Gen Map 0–6 Offset Address Low (I/O)	123
10.1.6	Gen Map 0–6 Offset Address High (I/O)	124
10.2	General Mapping Register for Memory Mode	125
10.2.1	Gen Map 0–6 Start Address Low (Memory)	125
10.2.2	Gen Map 0–6 Start Address High (Memory)	126
10.2.3	Gen Map 0–6 End Address Low (Memory)	127
10.2.4	Gen Map 0–6 End Address High (Memory)	128
10.2.5	Gen Map 0–6 Offset Address Low (Memory)	129
10.2.6	Gen Map 0–6 Offset Address High (Memory)	130

11. EXTENSION REGISTERS	131
11.1 Misc Control 1	132
11.2 FIFO Control	134
11.3 Misc Control 2	136
11.4 Chip Information	137
11.5 ATA Control	138
11.6 Extended Index	140
11.7 Extended Data	141
11.7.1 Extension Control 1	142
11.7.2 Gen Map 0–6 Upper Address (Memory)	143
11.7.3 Pin Multiplex Control 0 Register — PME_CXT	144
11.7.4 Pin Multiplex Control 1 Register — PME_CXT	146
11.7.5 GPIO Output Control	147
11.7.6 GPIO Input Control	147
11.7.7 GPIO Output Data	148
11.7.8 GPIO Input Data	148
11.8 Prefetch Window Register	149
11.8.1 PCI Space Control	149
11.8.2 PC Card Space Control	150
11.8.3 Window Type Select	150
11.8.4 Misc Control 3	151
11.8.5 SMBus Socket Power Control Address — PME_CXT	153
11.8.6 Gen Map 0–6 Extra Control (I/O)	154
11.8.7 Gen Map 0–6 Extra Control (Memory)	155
11.8.8 Extension Card Status Change	156
11.8.9 Misc Control 4	157
11.8.10 Misc Control 5	158
11.8.11 Misc Control 6	158
11.9 Device Identification and Implementation Scheme	159
11.9.1 Mask Revision Byte	159
11.9.2 Product ID Byte	160
11.9.3 Device Capability Byte A	161
11.9.4 Device Capability Byte B	162
11.9.5 Device Implementation Byte A	163
11.9.6 Device Implementation Byte B	164
11.9.7 Device Implementation Byte C	165
11.9.8 Device Implementation Byte D	166
12. TIMING REGISTERS	167
12.1 Setup Timing 0–1	167
12.2 Command Timing 0–1	168
12.3 Recovery Timing 0–1	169
13. DMA OPERATION REGISTERS	171
13.1 Low Address	172
13.2 Mid Low Address	172
13.3 Mid High Address	173
13.4 High Address	173
13.5 Low Count	174
13.6 Mid Count	174
13.7 High Count	174

13.8	DMA Command and Status	175
13.9	Request Register	176
13.10	Mode Register.....	177
13.11	Master Clear.....	178
13.12	Mask Register	178
14.	ATA MODE OPERATION	179
15.	ELECTRICAL SPECIFICATIONS	181
15.1	Absolute Maximum Ratings	181
15.2	DC Specifications.....	181
15.3	AC Timing Specifications	185
15.3.1	PCI Bus Timing	186
15.3.2	System Interrupt Timing	191
15.3.3	PC Card (PCMCIA) Bus Timing Calculations.....	192
15.3.4	PC Card (PCMCIA) Bus Timing	193
16.	PACKAGE SPECIFICATIONS.....	199
17.	ORDERING INFORMATION	201
A.	PIN LISTINGS.....	203
	INDEX.....	211

1. CONVENTIONS

This section presents conventions used in this document.

General Conventions

Bits within words and words within various memory spaces are generally numbered with 0 (zero) as the least-significant bit or word. For example, the least-significant bit of a byte is bit 0, and the most-significant bit is bit 7.

In addition, number ranges for bit fields and words are presented with the most-significant value first. Thus, when discussing a bit field within a register, the bit number of the most-significant bit is written first, followed by a colon (:), and then the bit number of the least-significant bit; for example, bits 7:0.

In this document, the names of the CL-PD6833 internal registers are boldface. For example, **Chip Revision** and **Power Control** are register names. The names of bit fields are written with initial uppercase letters. For example, Card Power On and Battery Voltage Detect are bit field names.

Abbreviations and Acronyms

The following table lists abbreviations and acronyms used in this document.

Acronym or Abbreviation	Definition
AC	alternating current
ACPI	advanced configuration and power interface
ATA	AT-attachment
CIS	card information structure
DAC	digital-to-analog converter
DC	direct current
DMA	direct memory access
EEPROM	electrically erasable/programmable read-only memory
EEROM	electrically erasable read-only memory
GPIO	general-purpose I/O
IDE	integrated device electronics
IRQ	interrupt request
ISA	industry standard architecture
JEIDA	Japanese Electronic Industry Development Association

Acronym or Abbreviation	Definition (cont.)
LQFP	low-profile quad flat pack
LSB	least-significant bit
MQFP	metric quad flat pack
MSB	most-significant bit
MUX	multiplexer
PCI	peripheral component interconnect
PCM	pulse coded modulation
PCMCIA	Personal Computer Memory Card International Association
PME	power management enable
R2	Release 2 (PC Card 16)
RFU	reserved for future use
RU	read update
SIC	serial interrupt controller
SMBus™	system management bus
VGA	video graphics array
ZV	zoomed video

Measurement Abbreviations

Symbol	Units of measure
°C	degree Celsius
Gbyte	gigabyte (2^{30} or 1,073,741,824 bytes)
Hz	hertz (cycle per second)
Kbyte	kilobyte (2^{10} or 1,024 bytes)
kHz	kilohertz (1,000 hertz)
Mbyte	megabyte (2^{20} or 1,048,576 bytes)
MHz	megahertz (1,000,000 hertz)
μA	microampere
μs	microsecond (1,000 nanoseconds)
mA	milliampere
ms	millisecond (1,000 microseconds)
ns	nanosecond
pF	picofarad
V	volt

NUMBERS

Hexadecimal numbers are presented with all letters in uppercase and a lowercase h appended. For example, *14h* and *03CAh* are hexadecimal numbers.

Binary numbers are enclosed in single quotation marks when in text. For example, '11' is a binary number.

Numbers not indicated by an *h* or single quotation marks are decimal.

The use of 'tbd' indicates values that are 'to be determined', 'n/a' designates 'not available', and 'n/c' indicates a pin that is a 'no connect'.

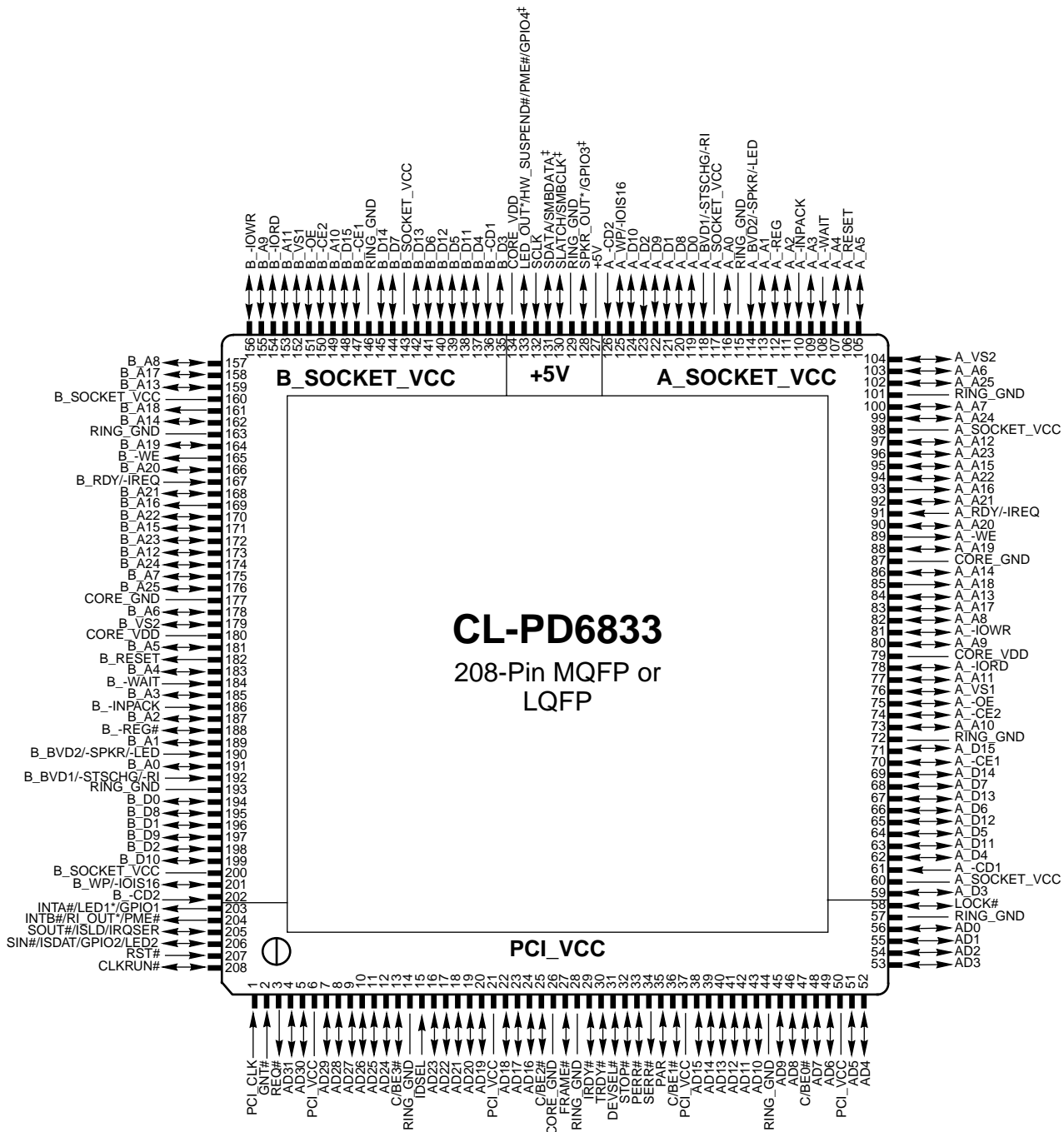
In addition, an uppercase *X* is used within numbers to indicate digits ignored by the CL-PD6833 within the current context. For example, '101XX01' is a binary number with bits 3:2 ignored.

2. PIN INFORMATION

The CL-PD6833 is packaged in a 208-pin MQFP (formerly PQFP) or LQFP (formerly VQFP) component package. The CL-PD6833 interface pins can be divided into four groups:

- PCI bus interface pins
- PC Card socket interface pins (two sets)
- Power control and general interface pins
- Power and ground pins

Refer to Figures [2-1](#) and [2-2](#) for the CL-PD6833 pin diagrams. The pin assignments and descriptions for the four groups of interface pins are shown in [Table 2-1](#) through [Table 2-4](#). Refer to [Appendix A](#) for pin listings using the PC Card 16 (R2) and PC Card 32 (CardBus) signal names in numerical and alphabetical order. Also refer to [Appendix A](#) for the PC Card Socket signal names and PCI Bus pin listing.

2.1 Pin Diagrams


NOTE: A double-dagger superscript (\ddagger) at the end of the pin name indicates signals that are used for power-on configuration switches.

Figure 2-1. Pin Diagram for PC Card 16 (R2)

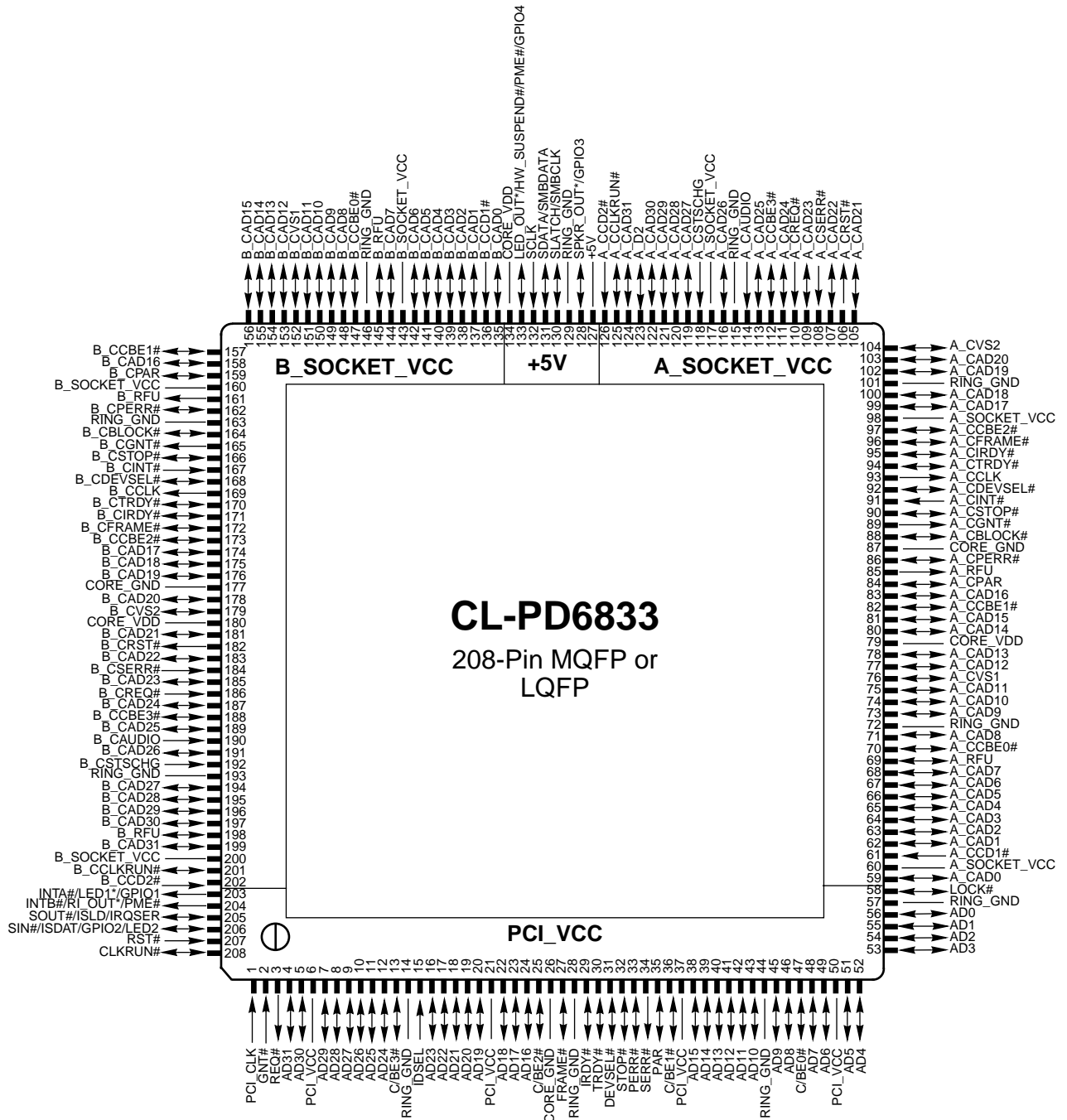


Figure 2-2. Pin Diagram for PC Card 32 (CardBus)

2.2 Pin Description Conventions

The following conventions apply to the pin description tables in [Section 2.3](#):

- A pound sign (#) at the end of a pin name indicates an active-low signal for the PCI bus, CardBus, and PCMCIA bus.
- A dash (-) at the beginning of a pin name indicates an active-low signal for the PCMCIA bus.
- An asterisk (*) at the end of a pin name indicates an active-low signal that is a general interface for the CL-PD6833.
- A double-dagger superscript (‡) at the end of the pin name indicates signals that are used for power-on configuration switches.
- A pin name ending in bracketed digits separated by a colon [n:n] indicates a multi-pin bus.
- The pin number (Pin Number) column indicates the package pin that carries the listed signal. Note that multi-pin buses are listed with the first pin number corresponding to the most-significant bit of the bus. For example, if pin numbers 4, 5, 7–12, 16–20, 22–24, 38–43, 45–46, 48–49, and 51–56 are associated with PCI Bus Address Input and Data Input/Output pins AD[31:0], then the following pins correspond:
 - AD31 is pin 4
 - AD1 is pin 55
 - AD0 is pin 56
- The quantity (Qty.) column indicates the number of pins used (per socket where applicable).
- The I/O-type code (I/O) column indicates the input and output configurations of the pins on the CL-PD6833. The possible types are defined below.
- The power-type code (Pwr.) column indicates the output drive power source for an output pin or the pull-up power source for an input pin on the CL-PD6833. The possible types are defined below.

I/O Type	Description
I	Input pin
I-PU	Input pin with internal pull-up resistor
O	Constant-driven output pin
I/O	Input/output pin
O-OD	Open-drain output pin
O-TS	Tristate output pin
GND	Ground pin
PWR	Power pin

Power Type	Output or Pull-up Power Source
1	+5V: powered from a 5-volt power supply (in most systems, see description of +5V pin in Table 2-4)
2	A_SOCKET_VCC: powered from the Socket A V _{CC} supply connecting to PC Card pins 17 and 51 of Socket A
3	B_SOCKET_VCC: powered from the Socket B V _{CC} supply connecting to PC Card pins 17 and 51 of Socket B
4	PCI_VCC: powered from the PCI bus power supply
5	CORE_VDD: powered from a 3.3-volt power supply

NOTE: All pin inputs are referenced to CORE_VDD, independent of their output supply voltage.

- The drive-type (Drive) column describes the output drive-type of the pin (see DC specifications in [Chapter 15](#) for more information). Note that the drive type listed for an input-only (I) pin is not applicable (–).

2.3 Pin Descriptions

Table 2-1. PCI Bus Interface Pins

Pin Name	Description	Pin Number	Qty.	I/O	Pwr.	Drive
AD[31:0]	PCI Bus Address / Data Input/Outputs: These pins connect to PCI bus signals AD[31:0].	4–5, 7–12, 16–20, 22–24, 38–43, 45–46, 48–49, 51–56	32	I/O	4	PCI Spec.
C/BE[3:0]#	PCI Bus Command / Byte Enables: The command signalling and byte enables are multiplexed on the same pins. During the address phase of a transaction, C/BE[3:0]# are interpreted as the bus commands. During the data phase, C/BE[3:0]# are interpreted as byte enables. The byte enables are valid for the entirety of each data phase, and they indicate which bytes in the 32-bit data path carry meaningful data for the current data phase.	13, 25, 36, 47	4	I/O	4	PCI Spec.
FRAME#	Cycle Frame: This signal, driven by current master, indicates that a bus transaction is beginning. While FRAME# is asserted, data transfers continue. When FRAME# is deasserted, the transaction is in its final phase.	27	1	I/O	4	PCI Spec.
IRDY#	Initiator Ready: This signal indicates the initiating agent's ability to complete the current data phase of the transaction. IRDY# is used in conjunction with TRDY#.	29	1	I/O	4	PCI Spec.
TRDY#	Target Ready: This signal indicates the target agent's ability to complete the current data phase of the transaction. TRDY# is used in conjunction with IRDY#.	30	1	I/O	4	PCI Spec.
STOP#	Stop: This signal indicates the current target is requesting the master to stop the current transaction.	32	1	I/O	4	PCI Spec.
LOCK#	Lock Transaction: This signal is used by a PCI master to perform a locked transaction to a target memory. LOCK# is used to prevent more than one master from using a particular system resource.	58	1	I/O	4	PCI Spec.
IDSEL	Initialization Device Select: This input is used as a chip select during configuration read and write transactions. This is a point-to-point signal. The CL-PD6833 must be connected to its own unique IDSEL line (from the PCI bus arbiter or one of the most-significant AD bus pins).	15	1	I	–	–
DEVSEL#	Device Select: When actively driven, this signal indicates that it has decoded its own PCI address as the target of the current access. As an input, DEVSEL# indicates to the CL-PD6833 whether any device on the bus has been selected.	31	1	I/O	4	PCI Spec.
PERR#	Parity Error: The CL-PD6833 drives this output active (low) if it detects a data parity error during a write phase.	33	1	I/O	4	PCI Spec.

Table 2-1. PCI Bus Interface Pins (cont.)

Pin Name	Description	Pin Number	Qty.	I/O	Pwr.	Drive
SERR#	System Error: This output is pulsed by the CL-PD6833 to indicate an address parity error.	34	1	O-OD	4	PCI Spec.
PAR	Parity: This pin is sampled by the clock cycle after completion of each corresponding address or write data phase. For read operations, this pin is driven from the cycle after TRDY# is asserted until the cycle after completion of each data phase. It ensures even parity across AD[31:0] and C/BE[3:0]#.	35	1	I/O	4	PCI Spec.
PCI_CLK	PCI Clock: This input provides timing for all transactions on the PCI bus to and from the CL-PD6833. All PCI bus interface signals described in this table (Table 2-1), except RST#, INTA#, and INTB# are sampled on the rising edge of PCI_CLK; and all the CL-PD6833 PCI bus interface timing parameters are defined with respect to this edge. This input can be operated at frequencies from 0 to 33 MHz.	1	1	I	–	–
RST#	Device Reset: This input is used to initialize all registers and internal logic to their reset states and place all the CL-PD6833 pins in a high-impedance state.	207	1	I	–	–
INTA#/LED1*/GPIO1	<p>PCI Bus Interrupt A: This output indicates a programmable interrupt request generated from any of a number of card actions.</p> <p>Although there is no specific mapping requirement for connecting interrupt lines from the CL-PD6833 to the system, a common use is to connect this pin to the PCI bus INTA# interrupt line and use PCI Interrupt Signalling mode (see the register at memory offset 930h, Misc Control 5 on page 158).</p> <p>LED1*: This feature is only available in PCI/Way interrupt signalling mode (see the register at memory offset 930h, Misc Control 5 on page 158).</p> <p>General-Purpose Input/Output 1: This pin can also be used for either input or output under the control of the GPIO Input Control and GPIO Output Control registers (see also the Pin Multiplex Control 0 register at memory offset 914h). This pin is grouped with and powered from the PCI_VCC pin.</p>	203	1	O-TS	4	PCI Spec.
INTB#/RI_OUT*/PME#	<p>PCI Bus Interrupt B: In PCI Interrupt Signalling mode, this output can be used as an interrupt output connected to the PCI bus INTB# interrupt line.</p> <p>Ring Indicate Output: If Misc Control 2 register bit 7 is '1', this pin works as a ring indicate output from a socket's BVD1/-STSCHG/-RI input. Ring indicate capability is available in all of the Interrupt Signalling modes. RI_OUT* and INTB# are open-drain outputs.</p> <p>Power Management Event: This signal is used to indicate that a card or the controller needs service when it is in a power state that prohibits the use of an interrupt (see also the Pin Multiplex Control 0 register at memory offset 914h).</p>	204	1	OD, O-TS	4	PCI Spec.

Table 2-1. PCI Bus Interface Pins (cont.)

Pin Name	Description	Pin Number	Qty.	I/O	Pwr.	Drive
CLKRUN#	Clock Run: This pin is an input to indicate the status of PCI_CLK and an open-drain output to request the starting or speeding up of PCI_CLK. This pin complies with the <i>PCI Mobile Design Guide</i> .	208	1	I/O	4	PCI Spec.
GNT#	Grant: This signal indicates that access to the bus has been granted.	2	1	I	–	–
REQ#	Request: This signal indicates to the arbiter that the CL-PD6833 requests use of the bus.	3	1	O	4	PCI Spec.
PCI_VCC	PCI Bus V_{CC}: These pins can be connected to either a 3.3- or 5-V power supply. The PCI bus interface pin outputs listed in this table (Table 2-1) operate at the voltage applied to these pins, independent of the voltage applied to other CL-PD6833 pin groups.	6, 21, 37, 50	4	PWR	–	–

Table 2-2. Socket Interface Pins

Pin Name ¹	Description ²	Pin Number		Qty.	I/O	Pwr.	Drive
		Socket A	Socket B				
-REG/ CCBE3#	Register Access: During PC Card 16 memory cycles, this output chooses between attribute and common memory. During I/O cycles for non-DMA transfers, this signal is active (low). During ATA mode, this signal is always inactive. For DMA cycles on the CL-PD6833 to a DMA-capable card, -REG is inactive during I/O cycles to indicate DACK to the PC Card 16. In CardBus mode, this pin is the command and byte enable 3.	112	188	1	I/O	2 or 3	Card-Bus spec.
A[25:24]/ CAD[19, 17]	PC Card 16 socket address 25:24 outputs. In CardBus mode, these pins are the CardBus address/data bits 19 and 17, respectively.	102, 99	176, 174	2	I/O	2 or 3	Card-Bus spec
A23/ CFRAME#	PC Card 16 socket address 23 output. In CardBus mode, this pin is the CardBus FRAME# signal.	96	172	1	I/O PU	2 or 3	Card-Bus spec
A22/ CTRDY#	PC Card 16 socket address 22 output. In CardBus mode, this pin is the CardBus TRDY# signal.	94	170	1	I/O PU	2 or 3	Card-Bus spec

¹ To differentiate the sockets in the pin diagram, all socket-specific pins have either A_ or B_ prepended to the pin names indicated. For example, A_A[25:0] and B_A[25:0] are the independent address buses to the sockets.

² When a socket is configured as an ATA drive interface, socket interface pin functions change. See Chapter 14.

Table 2-2. Socket Interface Pins (cont.)

Pin Name ¹	Description ²	Pin Number		Qty.	I/O	Pwr.	Drive
		Socket A	Socket B				
A21/ CDEVSEL#	PC Card 16 socket address 21 output. In CardBus mode, this pin is the CardBus DEVSEL# signal.	92	168	1	I/O PU	2 or 3	Card- Bus spec
A20/ CSTOP#	PC Card 16 socket address 20 output. In CardBus mode, this signal is the Card- Bus STOP# signal.	90	166	1	I/O PU	2 or 3	Card- Bus spec
A19/ CBLOCK#	PC Card 16 socket address 19 output. In CardBus mode, this signal is the Card- Bus LOCK# signal used for locked trans- actions.	88	164	1	I/O PU	2 or 3	Card- Bus spec
A18/ RFU	PC Card 16 socket address 18 output. In CardBus mode, this pin is reserved for future use.	85	161	1	O	2 or 3	Card- Bus spec
A17/ CAD16	PC Card 16 socket address 17 output. In CardBus mode, this pin is the CardBus address/data bit 16.	83	158	1	I/O	2 or 3	Card- Bus spec
A16/ CCLK	PC Card 16 socket address 16 output. In CardBus mode, this pin supplies the clock to the inserted card.	93	169	1	O	2 or 3	Clock spec.
A15/ CIRDY#	PC Card 16 socket address 15 output. In CardBus mode, this pin is the CardBus IRDY# signal.	95	171	1	I/O PU	2 or 3	Card- Bus spec.
A14/ CPERR#	PC Card 16 socket address 14 output. In CardBus, this pin is the CardBus PERR# signal.	86	162	1	I/O PU	2 or 3	Card- Bus spec.
A13/ CPAR	PC Card 16 socket address 13 output. In CardBus mode, this pin is the CardBus PAR signal.	84	159	1	I/O	2 or 3	Card- Bus spec.
A12/ CCBE2#	PC Card 16 socket address 12 output. In CardBus mode, this pin is the command and byte enable 2.	97	173	1	I/O	2 or 3	Card- Bus spec.
A[11:9]/ CAD[12, 9, 14]	PC Card 16 socket address 11:9 outputs. In CardBus mode, these pins are the CardBus address/data bits 12, 9, and 14, respectively.	77, 73, 80	153, 149, 155	3	I/O	2 or 3	Card- Bus spec.
A8/ CCBE1#	PC Card 16 socket address 8 output. In CardBus mode, this pin is the command and byte enable 1.	82	157	1	I/O	2 or 3	Card- Bus spec.

¹ To differentiate the sockets in the pin diagram, all socket-specific pins have either A_ or B_ prepended to the pin names indicated. For example, A_A[25:0] and B_A[25:0] are the independent address buses to the sockets.

² When a socket is configured as an ATA drive interface, socket interface pin functions change. See [Chapter 14](#).

Table 2-2. Socket Interface Pins (cont.)

Pin Name ¹	Description ²	Pin Number		Qty.	I/O	Pwr.	Drive
		Socket A	Socket B				
A[7:0]/ CAD[26:20, 18]	PC Card 16 socket address 7:0 outputs. In CardBus mode, these pins are the CardBus address/data bits 18 and 20–26, respectively.	100, 103, 105, 107, 109, 111, 113, 116	175, 178, 181, 183, 185, 187, 189, 191	8	I/O	2 or 3	Card-Bus spec.
D15/ CAD8	PC Card 16 socket data I/O bit 15. In CardBus mode, this pin is the CardBus address/data bit 8.	71	148	1	I/O	2 or 3	Card-Bus spec.
D14/ RFU	PC Card 16 socket data I/O bit 14. In CardBus mode, this pin is reserved for future use.	69	145	1	I/O	2 or 3	Card-Bus spec.
D[13:3]/ CAD[6, 4, 2, 31, 30, 28, 7, 5, 3, 1, 0]	PC Card 16 socket data I/O bits 13:3. In CardBus mode, these pins are the CardBus address/data bits 6, 4, 2, 31, 30, 28, 7, 5, 3, 1, and 0, respectively.	67, 65, 63, 124, 122, 120, 68, 66, 64, 62, 59	142, 140, 138, 199, 197, 195, 144, 141, 139, 137, 135	11	I/O	2 or 3	Card-Bus spec.
D2/ RFU	PC Card 16 socket data I/O bit 2. In CardBus mode, this pin is reserved for future use.	123	198	1	I/O	2 or 3	Card-Bus spec.
D[1:0]/ CAD[29, 27]	PC Card 16 socket data I/O bits 1:0. In CardBus mode, these pins are the CardBus address/data bits 29 and 27, respectively.	121, 119	196, 194	2	I/O	2 or 3	Card-Bus spec.
-OE/ CAD11	Output Enable: This output goes active (low) to indicate a memory read from the PC Card 16 socket to the CL-PD6833. In CardBus mode, this pin is the CardBus address/data bit 11.	75	151	1	I/O	2 or 3	Card-Bus spec.
-WE/ CGNT#	Write Enable: This output goes active (low) to indicate a memory write from the CL-PD6833 to the PC Card 16 socket. In CardBus mode, this pin is the CardBus GNT# signal.	89	165	1	O	2 or 3	Card-Bus spec.
-IORD/ CAD13	I/O Read: This output goes active (low) for I/O reads from the socket to the CL-PD6833. In CardBus mode, this pin is the CardBus address/data bit 13.	78	154	1	O-TS	2 or 3	Card-Bus spec.
-IOWR/ CAD15	I/O Write: This output goes active (low) for I/O writes from the CL-PD6833 to the socket. In CardBus mode, this pin is the CardBus address/data bit 15.	81	156	1	I/O	2 or 3	Card-Bus spec.

¹ To differentiate the sockets in the pin diagram, all socket-specific pins have either A_ or B_ prepended to the pin names indicated. For example, A_A[25:0] and B_A[25:0] are the independent address buses to the sockets.

² When a socket is configured as an ATA drive interface, socket interface pin functions change. See [Chapter 14](#).

Table 2-2. Socket Interface Pins (cont.)

Pin Name ¹	Description ²	Pin Number		Qty.	I/O	Pwr.	Drive
		Socket A	Socket B				
WP/ -IOIS16/ CCLKRUN#	Write Protect / I/O Is 16-Bit: In Memory Card Interface mode, this input is interpreted as the status of the write protect switch on the PC Card 16. In I/O Card Interface mode, this input indicates the size of the I/O data at the current address on the PC Card 16. In CardBus mode, this pin is the CardBus CLKRUN# signal, which starts and stops the CardBus clock (CCLK).	125	201	1	I/O- PU	2 or 3	Card- Bus spec.
-INPACK/ CREQ#	Input Acknowledge: The -INPACK function is not applicable in PCI bus environments. This pin should be connected to the PC Card socket's -INPACK pin, since this can be the DREQ signal during DMA cycles. In CardBus mode, this pin is the CardBus REQ# signal.	110	186	1	I-PU	2 or 3	–
RDY/ -IREQ/ CINT#	Ready / Interrupt Request: In Memory Card Interface mode, this input indicates to the CL-PD6833 that the card is either ready or busy. In I/O Card Interface mode, this input indicates a card interrupt request. In CardBus mode, this pin is the CardBus Interrupt Request signal. This signal is active-low and level-sensitive.	91	167	1	I-PU	2 or 3	–
-WAIT/ CSERR#	Wait: This input indicates a request by the card, to the CL-PD6833, to halt the cycle in progress until this signal is deactivated. In CardBus mode, this pin is the CardBus SERR# signal.	108	184	1	I-PU	2 or 3	–
-CD[2:1]/ CCD[2:1]#	Card Detect: These inputs indicate to the CL-PD6833 that a card is in the socket. They are internally pulled high to the voltage of the +5V power pin. In CardBus mode, these inputs are used in conjunction with CVS[2:1] to detect the presence and type of card.	126, 61	202, 136	2	I-PU	1	–

¹ To differentiate the sockets in the pin diagram, all socket-specific pins have either A_ or B_ prepended to the pin names indicated. For example, A_A[25:0] and B_A[25:0] are the independent address buses to the sockets.

² When a socket is configured as an ATA drive interface, socket interface pin functions change. See [Chapter 14](#).

Table 2-2. Socket Interface Pins (cont.)

Pin Name ¹	Description ²	Pin Number		Qty.	I/O	Pwr.	Drive
		Socket A	Socket B				
-CE2/ CAD10	Card Enable: This pin is driven low by the CL-PD6833 during card access cycles to control byte/word card access. -CE1 enables even-numbered address bytes, and -CE2 enables odd-numbered address bytes. When configured for 8-bit cards, only -CE1 is active and A0 is used to indicate access of odd- or even-numbered bytes. In CardBus mode, this pin is the CardBus address/data bit 10.	74	150	1	I/O	2 or 3	Card-Bus spec.
-CE1/ CCBE0#	Card Enable: This pin is driven low by the CL-PD6833 during card access cycles to control byte/word card access. -CE1 enables even-numbered address bytes, and -CE2 enables odd-numbered address bytes. When configured for 8-bit cards, only -CE1 is active and A0 is used to indicate access of odd- or even-numbered bytes. In CardBus mode, this pin is the command and byte enable 0.	70	147	1	I/O	2 or 3	Card-Bus spec.
RESET/ CRST#	Card Reset: This output is low for normal operation and goes high to reset the card. To prevent reset glitches to a card, this signal is high-impedance unless a card is seated in the socket, card power is applied, and the card's interface signals are enabled. In CardBus mode, this pin is the RST# input to the card, which is active-low.	106	182	1	O-TS	2 or 3	Card-Bus spec.
BVD2/ -SPKR/ -LED/ CAUDIO	Battery Voltage Detect 2 / Speaker / LED: In Memory Card Interface mode, this input serves as the BVD2 (battery warning status) input. In I/O Card Interface mode, this input can be configured as a card's -SPKR binary audio input. For ATA or non-ATA (SFF-68) disk-drive support, this input can also be configured as a drive-status LED input. In CardBus mode, this pin is the AUDIO input from the card.	114	190	1	I-PU	2 or 3	-

¹ To differentiate the sockets in the pin diagram, all socket-specific pins have either A_ or B_ prepended to the pin names indicated. For example, A_A[25:0] and B_A[25:0] are the independent address buses to the sockets.

² When a socket is configured as an ATA drive interface, socket interface pin functions change. See [Chapter 14](#).

Table 2-2. Socket Interface Pins (cont.)

Pin Name ¹	Description ²	Pin Number		Qty.	I/O	Pwr.	Drive
		Socket A	Socket B				
BVD1/ -STSCHG/ -RI / CSTSCHG	<p>Battery Voltage Detect 1 / Status Change / Ring Indicate: In Memory Card Interface mode, this input serves as the BVD1 (battery-dead status) input. In I/O Card Interface mode, this input is the -STSCHG input, which indicates to the CL-PD6833 that the card's internal status has changed. If bit 7 of the Interrupt and General Control register is set to '1', this pin serves as the ring indicate input for wakeup-on-ring system power management support.</p> <p>In CardBus mode, this pin is the CardBus Status Change used by the card to alert the system to changes in READY, WP, and BVD[2:1].</p>	118	192	1	I-PU	2 or 3	–
VS2/ CVS2	<p>Voltage Sense 2: This pin is used in conjunction with VS1 to determine the operating voltage of the card. This pin is internally pulled high to the voltage of the +5V power pin under the combined control of the external data write bits and the CD pull-up control bits. This pin connects to PC Card 16 socket pin 57.</p> <p>In CardBus mode, this is CardBus Voltage Sense 2. It is used in conjunction with CVS1, CCD1, and CCD2 to determine the initial voltage applied to the CardBus PC Card.</p>	104	179	1	I/O	1	2 mA
VS1/ CVS1	<p>Voltage Sense 1: This pin is used in conjunction with VS2 to determine the operating voltage of the card. This pin is internally pulled high to the voltage of the +5V power pin under the combined control of the external data write bits and the CD pull-up control bits. This pin connects to PC Card 16 socket pin 43.</p> <p>In CardBus mode, this is CardBus Voltage Sense 1. It is used in conjunction with CVS2, CCD1, and CCD2 to determine the initial voltage applied to the CardBus PC Card.</p>	76	152	1	I/O	1	2 mA

¹ To differentiate the sockets in the pin diagram, all socket-specific pins have either A_ or B_ prepended to the pin names indicated. For example, A_A[25:0] and B_A[25:0] are the independent address buses to the sockets.

² When a socket is configured as an ATA drive interface, socket interface pin functions change. See [Chapter 14](#).

Table 2-2. Socket Interface Pins (cont.)

Pin Name ¹	Description ²	Pin Number		Qty.	I/O	Pwr.	Drive
		Socket A	Socket B				
SOCKET_VCC	Connect these pins to the V _{CC} supply of the socket (pins 17 and 51 of the respective PC Card 16 socket). These pins can be 0, 3.3, or 5 V, depending on card presence, card type, and system configuration. The socket interface outputs (listed in this table, Table 2-2) operate at the voltage applied to these pins, independent of the voltage applied to other CL-PD6833 pin groups.	117, 98, 60	200, 160, 143	3	PWR	–	–

¹ To differentiate the sockets in the pin diagram, all socket-specific pins have either A_ or B_ prepended to the pin names indicated. For example, A_A[25:0] and B_A[25:0] are the independent address buses to the sockets.

² When a socket is configured as an ATA drive interface, socket interface pin functions change. See [Chapter 14](#).

Table 2-3. Power Control and General Interface Pins

Pin Name	Description	Pin Number	Qty.	I/O	Pwr.	Drive
SPKR_OUT* /GPIO3 [‡]	<p>Speaker Output: This output can be used as a digital output to a speaker to allow a system to support PC Card 16 fax/modem/voice and audio sound output. This output is enabled by setting the socket's Misc Control 1 register bit 4 to '1' (for the socket whose speaker signal is to be directed from BVD2/-SPKR/-LED to this pin). This pin is used for configuration information during hardware reset. Refer to Misc Control 3 register bit 0.</p> <p>General-Purpose Input/Output 3: This pin can also be used for either input or output under the control of the GPIO Input Control and GPIO Output Control registers (see also the Pin Multiplex Control 0 register at memory offset 914h). This pin is grouped with and powered from the +5V pins.</p>	128	1	I/O	1	8 mA

Table 2-3. Power Control and General Interface Pins (*cont.*)

Pin Name	Description	Pin Number	Qty.	I/O	Pwr.	Drive
LED_OUT*/ HW_SUSPEND#/ PME#/GPIO4 [‡]	<p>LED Output: This output can be used as an LED driver to indicate disk activity when a socket's BVD2/-SPKR/-LED pin has been programmed for LED support. The Extension Control 1 register bit 2 must be set to '1' to enable this output (to reflect any activity on BVD2/-SPKR/-LED), and a socket's ATA Control register bit 1 must be set to '1' to allow the level of the BVD2/-SPKR/-LED pin to reflect disk activity.</p> <p>Serves as a HW_SUSPEND# input pin, when Misc Control 3 register bit 4 is set to '1'.</p> <p>This pin is used for configuration information during hardware reset. Refer to Misc Control 3 register bit 1.</p> <p>General-Purpose Input/Output 4: This pin can also be used for either input or output under the control of the GPIO Input Control and GPIO Output Control registers. This pin is grouped with and powered from the +5V pins.</p> <p>Power Management Event: This signal is used to indicate that a card or the controller needs service and is in a power state that prohibits the use of an interrupt (see also the Pin Multiplex Control 0 register at memory offset 914h).</p>	133	1	I/O	1	8 mA
SCLK	<p>Serial Clock: This input is used as a reference clock (10–100 kHz, usually 32 kHz) to control the serial interface of the socket power control chips.</p> <p>CAUTION: This pin must be driven at all times. See Section 3.1.7.1 on page 35 for more information on socket power control.</p>	132	1	I	–	–
SDATA/ SMBDATA [‡]	<p>Serial Data / System Management Bus Data: This pin serves as output pin SDATA when used with the serial interface of Texas Instruments' TPS2206AIDF socket power control chip, and serves as a bidirectional pin SMBDATA when used with Intel's System Management Bus used by Maxim's socket power control chip. This pin is open drain for the SMBus mode of operation and requires an external pull-up.</p> <p>This pin is used to detect power-up during reset (see Section 3.2 on page 38).</p>	131	1	I/O	1	8 mA (for SDATA)

Table 2-3. Power Control and General Interface Pins (cont.)

Pin Name	Description	Pin Number	Qty.	I/O	Pwr.	Drive
SLATCH/ SMBCLK [‡]	<p>Serial Latch / System Management Bus Clock: This pin serves as output pin SLATCH when used with the serial interface of Texas Instruments' TPS2206AIDF socket power control chip, and serves as bidirectional pin SMBCLK when used with Intel's System Management Bus used by Maxim's socket power control chip. This pin is open drain in the SMBus mode of operation. In this mode an external pull up is required.</p> <p>This pin is used for configuration information during hardware reset. Refer to Misc Control 3 register bit 2.</p>	130	1	I/O- PU	1	8 mA (for SLATCH)
SOUT#/ISLD/ IRQSER	<p>Serial Interrupt Output / Serial IRQ Load: In PCI Interrupt Signalling mode, this pin is a no-connect.</p> <p>In PC/PCI Serial Interrupt Signalling mode, this pin is the serial interrupt output, SOUT#.</p> <p>In PCI/Way Interrupt Signalling mode, this pin is the IRQSER signal, which is bidirectional.</p> <p>In External-Hardware Interrupt Signalling mode, this pin is the load signal, ISLD, used to load the serially transmitted interrupt data into the external serial-to-parallel shifters.</p>	205	1	I/O	4	PCI Spec.
SIN#/ISDAT/ GPIO2/LED2	<p>Serial Interrupt Input / Serial IRQ Data: In PCI Interrupt Signalling mode, this pin is a no-connect.</p> <p>In PC/PCI Serial Interrupt Signalling mode, this pin is the serial interrupt input, SIN# (see the register at memory offset 930h, Misc Control 5 on page 158).</p> <p>In External-Hardware Interrupt Signalling mode, this pin is the IRQ vector data, ISDAT, that is serially transmitted to the external serial-to-parallel shifters.</p> <p>General-Purpose Input/Output 2: This pin can also be used for either input or output under the control of the GPIO Input Control and GPIO Output Control registers (see also the Pin Multiplex Control 0 register at memory offset 914h). This pin is grouped with and powered from the PCI_VCC pin.</p> <p>LED2: This feature is only available in PCI/Way interrupt signalling mode (see the register at memory offset 930h, Misc Control 5 on page 158).</p>	206	1	I/O	4	PCI Spec.

Table 2-4. Power and Ground Pins

Pin Name	Description	Pin Number	Qty.	I/O	Pwr.	Drive
+5V	This pin is connected to the system's 5-V power supply.	127	1	PWR	–	–
CORE_VDD	This pin provides power to the core circuitry of the CL-PD6833. This pin must be connected to the 3.3-V supply.	134, 79, 180	3	PWR	–	–
CORE_GND	All the CL-PD6833 ground lines should be connected to system ground.	26, 87, 177	3	GND	–	–
RING_GND	All the CL-PD6833 ground lines should be connected to system ground.	14, 28, 44, 57, 72, 101, 115, 129, 146, 163, 193	11	GND	–	–

3. INTRODUCTION TO THE CL-PD6833

3.1 System Architecture

This section describes the CL-PD6833 basic architecture in terms of PC Card functions. It first introduces PC Cards, the PCMCIA (Personal Computer Memory Card International Association), and the PC Card Standard, and then discusses how the CL-PD6833 complies with the standards. It also describes the windowing capabilities of the CL-PD6833.

3.1.1 PC Card Basics

PC Cards are credit-card-size peripherals that add memory and I/O capabilities to computers in a rugged, compact form factor. The PC Card Standard describes specifications for using these memory and I/O devices as insertable, exchangeable peripherals for personal and handheld computers. The PC Card Standard is published by the PCMCIA, a non-profit trade association that promotes PC Card technology by defining technical standards.

There are two types of PC Cards: PC Card 16 (R2) and PC Card 32 (CardBus). PC Card 16 (R2) cards are 16-bit cards that comply with PCMCIA Standard Releases 2.0, 2.01, and 2.1. In 1995, the PCMCIA released a standard for PC Cards in conjunction with the standard for the PC Card 16 (R2) architecture, and renamed the joint standard as PC Card Standard. This joint standard introduced 32-bit operation and support for PC Card 32 (CardBus) bus mastering cards. PC Card 32 (CardBus) cards are 32-bit cards that comply with the PC Card Standard first released in February 1995.

The CL-PD6833 implements both PC Card 16 (R2) and PC Card 32 (CardBus) functions. The R2 functions of the CL-PD6833 implement the functions described in the PCMCIA Standard Release 2.1, while the CardBus functions of the CL-PD6833 are compatible with the PC Card Standard. Under software control, the CL-PD6833 uses the VS1, VS2, CD1, and CD2 pins in the manner described by the PC Card Standard to identify and power up the PC Card. The PC Card type (R2 or CardBus) determines its voltage requirements.

For simpler end-user and vendor implementation of the standard, systems employing the PC Card Standard should also be backward-compatible with industry-standard PC addressing. The CL-PD6833 is backward-compatible with PCMCIA Standard Releases 1.0, 2.0, 2.01, and 2.1. The CL-PD6833 is also compatible with JEIDA 4.1 and earlier standards corresponding with the PCMCIA standards above.

PC Card 16 (R2) cards can have *attribute* and *common* memory. Attribute memory indicates to host software the capabilities of the PC Card, and it allows host software to change the configuration of the card. Common memory can be used by host software for any purpose such as flash file system, system memory, and floppy emulation.

For memory-type PC Card 16 (R2) cards, the memory information must be mapped into the system memory address space. This is accomplished with a 'windowing' technique that is similar to expanded memory schemes already used in PC systems (for example, LIM 4.0 memory manager).

I/O-type PC Card 16 (R2) cards, such as modems, should also be directly addressable, as if the cards were I/O devices plugged into the PCI bus. For example, it would be highly desirable to have a PC Card modem accessible to standard communications software as if it were at a COM port. For COM1, this would require that the modem be accessed at system I/O address 3F8h–3FFh. The method of mapping a PC Card I/O address into anticipated areas of PCI I/O space is similar to memory windowing.

3.1.2 CL-PD6833 R2 Windowing Capabilities

For full compatibility with existing software and to ensure compatibility with future R2 memory card and R2 multifunction I/O cards, the CL-PD6833 provides seven programmable general-purpose windows per socket. These windows default at reset to two I/O windows and five memory windows.

Any one of the seven windows can be programmed to respond on the PCI primary bus as either a memory or I/O window and to issue either a memory or I/O cycle to the R2-compatible PC Card. For example, in the case of a non-'X86 processor that must memory map I/O devices, a window would be set for memory on the primary PCI side and I/O on the R2-compatible PC Card side. Tables 3-1 and 3-2 show the programming options for each memory and I/O window.

Table 3-1. Memory Window Options

Memory Window Option	Description
Enable	Each of the seven windows can be programmed as a memory window and individually enabled. DEVSEL# is not asserted for disabled windows.
Start Address	This is the start address of the memory window within the selected 16-Mbyte page of PCI memory. The start address can be programmed to reside on any 4-Kbyte boundary within the programmed page of PCI memory.
End Address	This is the end address of the memory window within the selected 16-Mbyte page of PCI memory. The end address can be programmed to reside on any 4-Kbyte boundary within the programmed page of PCI memory. Only memory accesses between the start and end address get a response.
Offset Address	The offset address is added to the PCI address to determine the address for accessing the PC Card. This allows the addresses in the PC Card address space to be different from the PCI address space.
Upper Address	The upper memory address specifies a 16-Mbyte page of PCI memory.
Data Size	The size of accesses can be set manually to either 8 or 16 bits.
Timing	The timing of accesses (setup/command/recovery) can be set by either of two timing register sets: Timer Set 0 or Timer Set 1 .
Register Access Setting	The REG# pin can be enabled on a per-window basis so that any of the windows can be used for accessing attribute memory.
Write Protect	If the window is programmed to be write-protected, then writes to the memory window are ignored (reads are still performed normally).

Table 3-2. I/O Window Options

I/O Window Option	Description
Enable	Each of the seven windows can be programmed as an I/O window and individually enabled.
Start Address	The start address of the window is programmable on single-byte boundaries from 0 to 64 Kbytes.
End Address	The end address of the window is also programmable on single-byte boundaries from 0 to 64 Kbytes.
Offset Address	The offset address is added to the PCI address to determine the address for accessing the PC Card.
Auto Size	The size of accesses can be set automatically, based on the PC Card -IOIS16 signal.
Data Size	The size of accesses can be set manually to either 8 or 16 bits, overriding the auto size option.
Timing	The timing of accesses (setup/command/recovery) can be set by either of two timing register sets: Timer Set 0 or Timer Set 1 .

CAUTION: The windows of the CL-PD6833 should never be allowed to overlap with each other or the other devices in the system. This would cause signal collisions and result in erratic behavior.

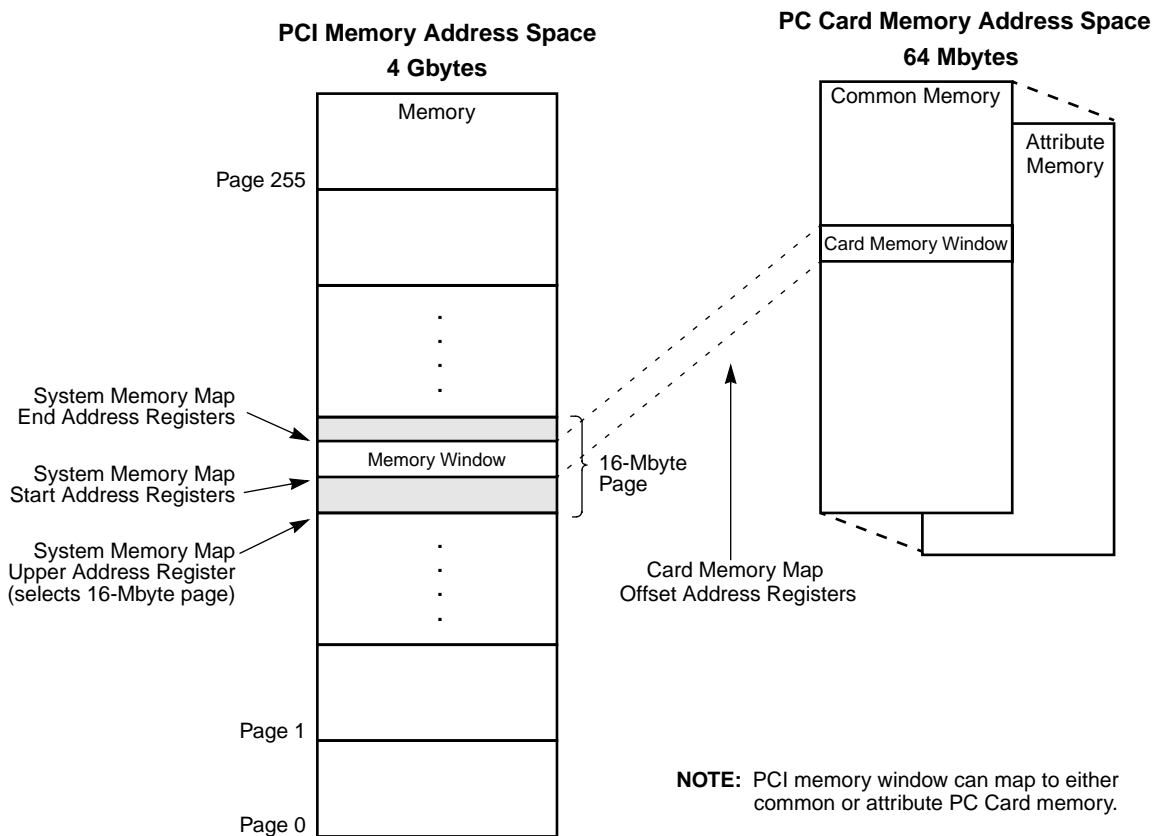


Figure 3-1. Memory-to-Memory Window Organization

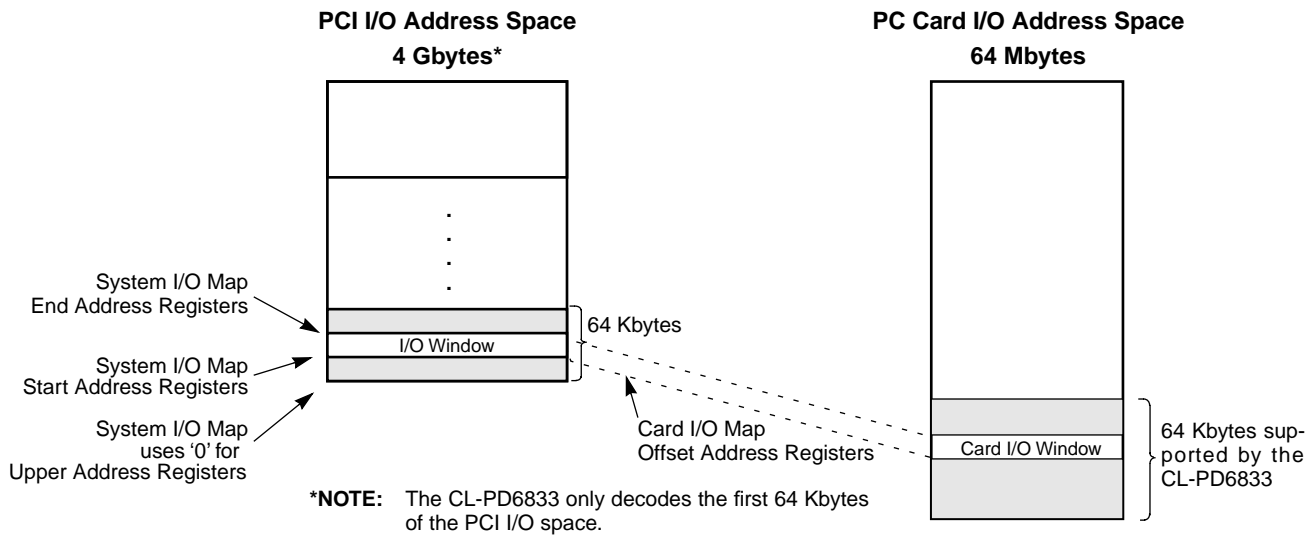


Figure 3-2. R2 I/O-to-I/O Window Organization

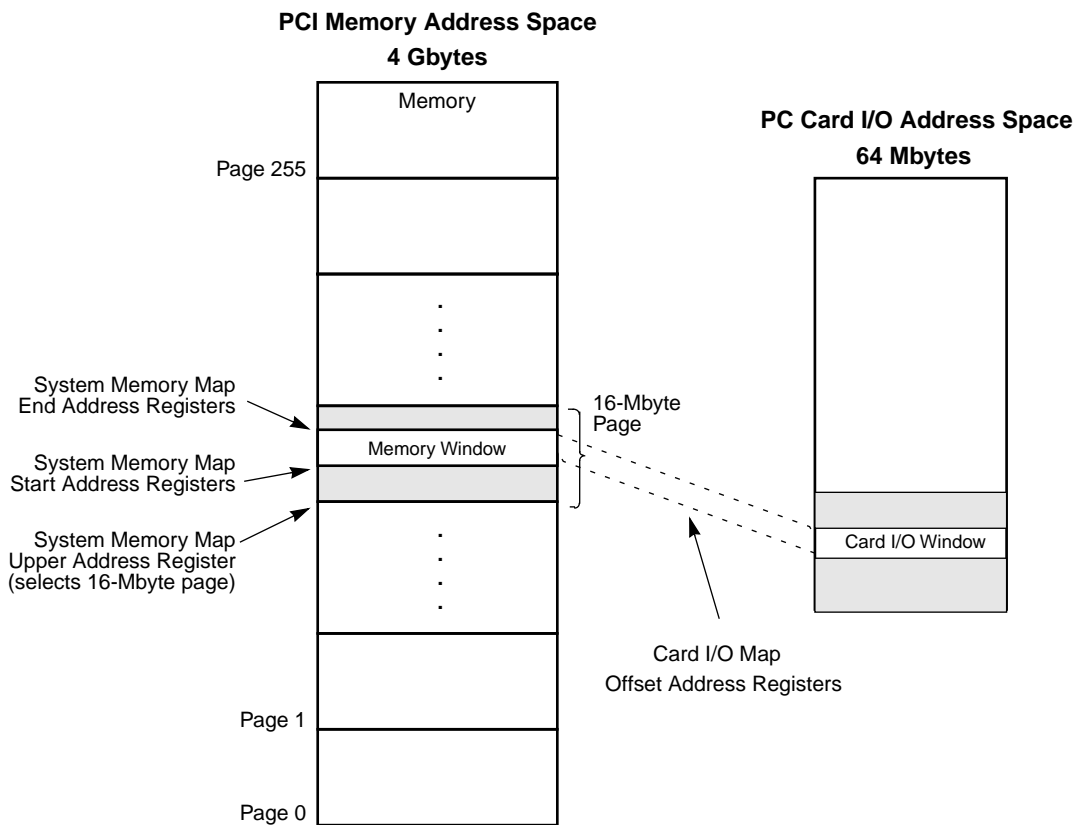


Figure 3-3. Memory-to-I/O Window Organization

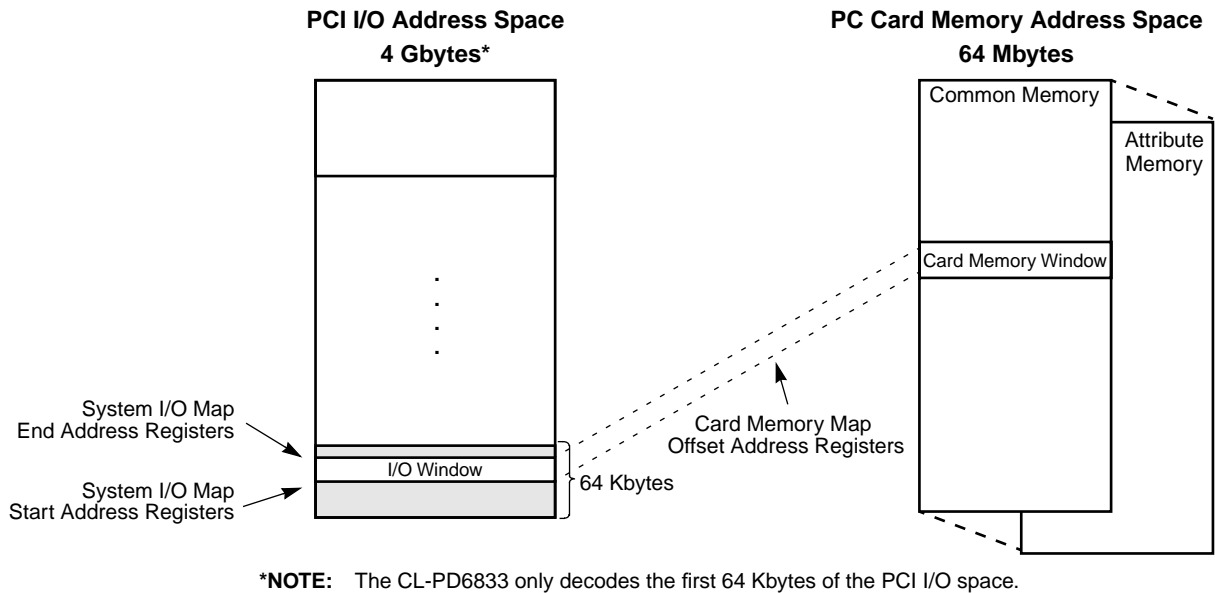


Figure 3-4. R2 I/O-to-Memory Window Organization

3.1.3 Zoomed Video Port

The CL-PD6833 supports the implementation of the ZV (zoomed video) Port at the PC Card interface. The ZV Port provides a direct connection between a PC Card, a VGA controller, and an audio DAC. It allows the PC Card to directly write video data to a graphics controller input port and audio data to a digital-to-analog converter.

The CL-PD6833 supports the ZV Port in the 'bypass' mode, during which the signals are directly routed from the PC Card bus to the video port of the VGA controller. Rerouting is accomplished by tristating address lines A[25:4] from the CL-PD6833. The CL-PD6833 enters the ZV Port mode when the Multimedia Enable bit (bit 0 of the **Misc Control 1** register at index 16h or memory offset 816h) is set to a '1'. The CL-PD6833 has a Multimedia Arm bit (bit 7 of the **Misc Control 3** register at I/O index 2Fh, Extended Index 25h, or memory offset 925h), which works as an overriding control bit. Until the Multimedia Arm bit is set, the Multimedia Enable bit does not tristate the address pins as previously described.

Figure 3-5 shows an example of the ZV Port implementation using the CL-PD6833. For more details, refer to the application note *Zoomed Video Port Implementation (AN-PD10)*.

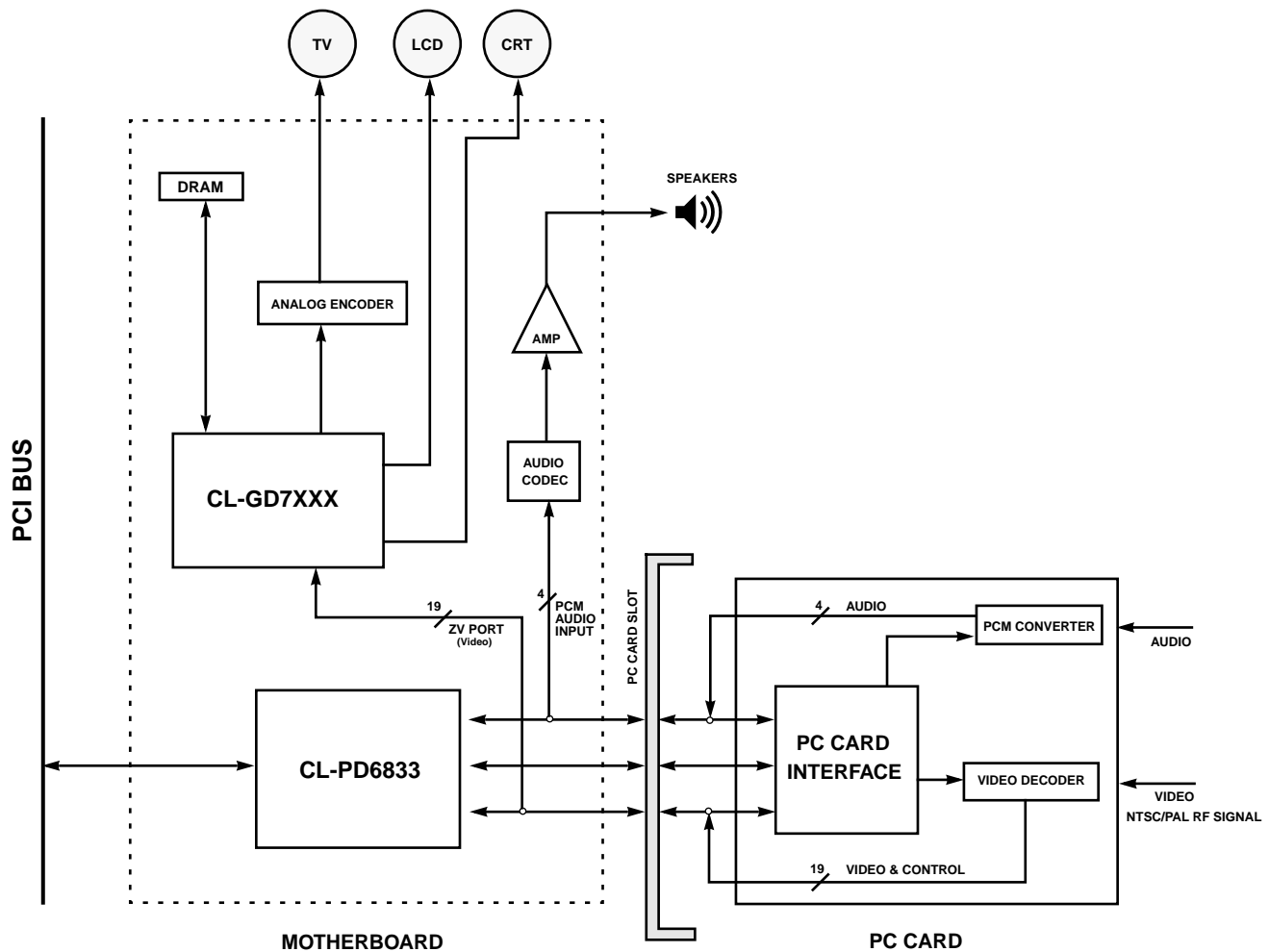


Figure 3-5. A Typical ZV Port Implementation

3.1.4 Interrupts

The I/O-type PC Cards usually have interrupts that need to be serviced by host software. For example, for a modem card accessed as if at COM1, the software would expect the modem to generate interrupts on the IRQ4 line. To be sure all interrupts are routed as expected, the CL-PD6833 can steer the interrupt from the PC Card to one of the four PCI-bus-defined interrupts or to one of several standard PC interrupts. The CL-PD6833 supports four interrupt schemes: PCI Interrupt, Intel's PC/PCI Serial Interrupt, PCI/Way Interrupt, and External-Hardware Interrupt.

The CL-PD6833 allows sharing of interrupts under software control. This is accomplished by programming the CL-PD6833 to alternately pulse and then tristate the desired interrupt pin. In addition, the CL-PD6833 allows two I/O devices to share one interrupt line in systems that have only one interrupt line and all interrupt requests are routed to that one interrupt line. For example, if two fax/modem cards are inserted into the dual-socket PC Card controller, and both are active and share the only interrupt line provided by the host system, then the application software can still identify the requester and the type of the pending interrupt.

The CL-PD6833 supports two classes of interrupts:

- Socket or card functional interrupts (initiated by the PC Card activating its RDY/-IREQ signal)
- Management interrupts (triggered by changes in PC Card status)

There are four changes in PC Card status that can be programmed to cause management interrupts:

- Card insertion or removal
- Battery dead indicator (BVD1) or I/O-type card status change (-STSCHG)
- Battery warning indicator (BVD2) change on a memory-type card
- Ready (RDY) status change on a memory-type card

Any interrupt from either class of interrupts can be steered by the CL-PD6833 to any interrupt output. This is useful because IRQ-type interrupts in PC-compatible systems are not generally shared by hardware. Therefore, each device in the system using IRQ-type interrupts must have a unique interrupt line. Additionally, many software applications assume that certain I/O devices use specific IRQ signals. To allow PC Cards with differing I/O functionality to be connected to appropriate non-conflicting IRQ locations, the CL-PD6833 can steer the interrupt signal from a PC Card to any one of ten interrupt outputs.

The CL-PD6833 provides four pins for interrupts. These pins have multiple functionality to allow the CL-PD6833 to output a number of specific interrupts, depending on which of four interrupt signalling modes is selected:

- PC/PCI Interrupt Signalling mode
- External-Hardware Interrupt Signalling mode
- PCI/Way Interrupt Signalling mode
- PCI Interrupt Signalling mode

The Interrupt Signalling mode is usually established during power-on reset by the level of pins 133 (LED_OUT*/HW_SUSPEND#) and 128 (SPKR_OUT*), but it can also be set by writing to bits 1:0 of the **Misc Control 3** register (memory offset 925h). Refer to [Table 3-3](#) for the interrupt signalling mode configuration.

Table 3-3. Interrupt Signalling Mode Configuration

Mode	LED_OUT*/ HW_SUSPEND#	SPKR_OUT*	Misc Control 3	
	(Pin 133)	(Pin 128)	Bit 1	Bit 0
PC/PCI	Pull-down	Pull-down	0	0
External-Hardware	Pull-down	Pull-up	0	1
PCI/Way	Pull-up	Pull-down	1	0
PCI	Pull-up	Pull-up	1	1

Note that depending on the mode, the INTB#/RI_OUT* pin can be configured to function as a ring indicator output (RI_OUT*) to an 80360-type chip set's -RI input. When configured in Ring Indicate mode by programming bit 7 of the **Misc Control 2** register (memory offset 81Eh) to '1', outputs from an I/O-type card's -STSCHG pin¹ are passed through to the INTB#/RI_OUT* pin of the CL-PD6833.

NOTE: This does not apply if the CL-PD6833 is programmed for PME.

¹ **Interrupt and General Control** register bits 5 and 7 must be set to '1's for a socket interface to accept an -RI input.

External-Hardware Interrupt Signalling Mode

In this mode, up to eight ISA IRQ interrupts and two PCI interrupts are supported. Two pins (pin 205 functioning as ISLD and pin 206 functioning as ISDAT) interface with external hardware, which converts the signals to appropriate ISA-type IRQ totem-pole interrupt outputs.

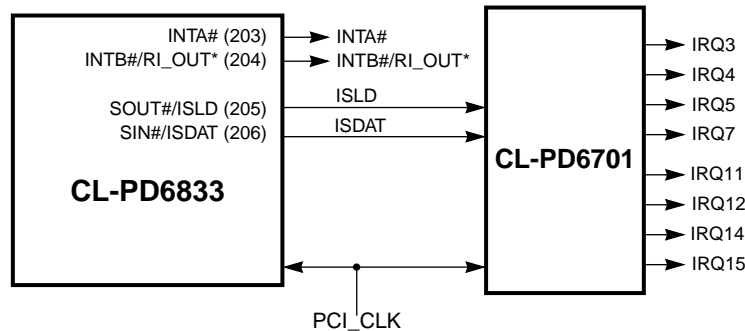


Figure 3-6. External-Hardware Interrupt Signalling Mode

The interrupts are serially passed on the ISDAT pin to the external hardware. The interrupts are shifted into the external serial-to-parallel converter using PCI_CLK. The interrupts are latched using the ISLD signal.

In this mode, pin 203 functions as INTA#, and pin 204 functions as INTB#/RI_OUT*. Refer to application note *Interrupt Signalling Modes for the CL-PD6730 and CL-PD6832 (AN-PD8)*.

This is the only mode that supports pulse mode interrupts. The CL-PD6833 contains unique logic that allows ISA-style, IRQ-type interrupts to be shared under software control. This is accomplished by programming the CL-PD6833 to alternately pulse and then tristate the desired interrupt pin, which is programmed as an IRQ-type output. This unique IRQ interrupt sharing technique requires additional software to allow for the sharing of interrupts.

PCI/Way Interrupt Signalling Mode

This mode of operation uses the PCI/Way single-pin interrupt system. In this mode one pin (pin 205) interfaces with a PCI/Way-compliant motherboard chip set.

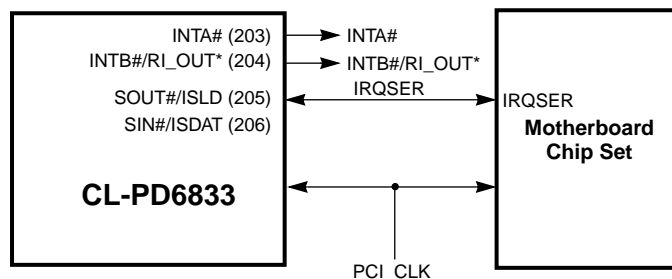
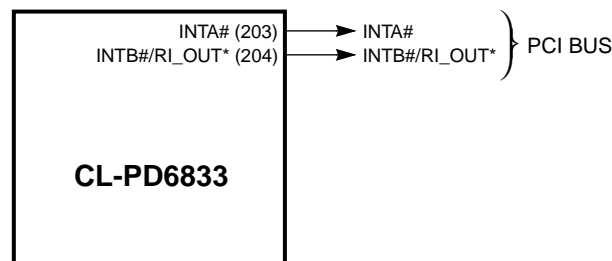


Figure 3-7. PCI/Way Serial Interrupt Signalling Mode

The SOUT#/ISLD/IRQSER pin on the CL-PD6833 is the bidirectional serial interrupt line. In this mode, pin 203 works as INTA# and pin 204 works as INTB#/RI_OUT*. Pin 206 is not used.

PCI Interrupt Signalling Mode

This is the default mode, as per the power-on-reset condition of the **Misc Control 3** register. It uses pins 203 and 204 directly as the PCI-type 'INT#' open-drain interrupts (refer to [Figure 3-8](#)). If the CL-PD6833 is not programmed for Ring Indicate, INTA# is used for function 0 and INTB# is used for function 1. If the CL-PD6833 is programmed for Ring Indicate, INTA# is used for both function 0 and 1. Ring-Indicate output appears on INTB#. Programming PC Card interrupts (**Interrupt and General Control** register, index 3h) or management interrupts (**Management Interrupt Configuration** register, index 5h) does not affect PCI mode.



**Figure 3-8. PCI Interrupt Signalling Mode
 (A Common Interrupt Mapping)**

PC/PCI Serial Interrupt Signalling Mode

This mode supports the Mobile PC/PCI Extended Interrupt Programming Model. In this mode, two pins (pin 205 functioning as SOUT# and 206 functioning as SIN#) interface with an SIC (serial interrupt controller). The number of interrupts supported depends on the SIC configuration.

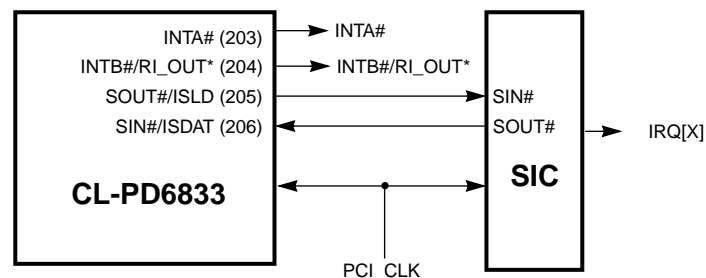


Figure 3-9. PC/PCI Serial Interrupt Signalling Mode

The SIN# pin on the CL-PD6833 is the serial interrupt input line from other devices in the interrupt loop, and the SOUT# pin is the serial interrupt output line containing the logical 'AND' of the interrupt level in the CL-PD6833, along with SIN# interrupts. The SIC is clocked by PCI_CLK, and CLKRUN# is used by the CL-PD6833 to restart PCI_CLK if it has stopped.

In this mode, pin 204 is INTB#/RI_OUT* and pin 203 is INTA#. Program **Misc Control 2** register bit 7 to '1' for ring indicate function.

3.1.5 PCI/Way DMA

The CL-PD6833 supports the PCI/Way DMA (direct memory access). This DMA approach is applicable to a PC system that does not have an ISA bus as its main system bus. The approach requires that two or more devices (on a non-ISA bus) support legacy DMA. Since the PCI/Way DMA specification describes an approach that distributes independent, standard programming model bus-master channels among devices, it is also popularly known as distributed DMA.

The CL-PD6833 provides complete, seamless support for DMA-capable PC Cards on the PCMCIA bus as outlined in the PC Card Standard. When a DMA-capable PC Card requests DMA operation, the CL-PD6833 uses the REQ#, GNT# protocol on the PCI bus to handle the DMA transfer. Programming registers in the CL-PD6833 reflects the functions found in the legacy 8237 DMA controller chip.

3.1.6 Power Management

The CL-PD6833 employs power management techniques to provide long battery life. This is achieved by minimizing the power consumption of the CL-PD6833 and that of the PC Cards. Substantial power is saved by turning off the PCI_CLK to the CL-PD6833 or reducing the frequency of that clock. More power can be saved by putting the CL-PD6833 in the HW (hardware) Suspend mode. To put the CL-PD6833 in the HW Suspend mode, bit 4 of the Miscellaneous Control 3 (extended I/O index 25h) must be set to '1'. Thereafter, the LED_OUT*/HW_SUSPEND# pin can be driven to a '0' logic state. While in the HW Suspend mode, the CL-PD6833 tristates all its outputs except the REQ# signal, which is driven high.

During HW Suspend mode, the PCI bus signals to the CL-PD6833 can be turned off. However, the RST# signal on the PCI bus must always be held high. An inactive state of the RST# signal ensures that the internal state of the CL-PD6833 is maintained during the power-down modes. [Table 3-4](#) illustrates the various power management modes and the corresponding power consumption.

Table 3-4. Power Consumption in Various Modes

Mode Name	RST# level	Measurement Conditions	Typical Power Consumption
Normal Operation	High	CL-PD6833 fully functional PCI Bus active Core_VDD = 3.3 V PCI_VCC,+5V = 5 V Clock = 33 MHz	tbd
PCI_CLK Stopped	High	Only interrupts and RI_OUT* available ^a PCI Bus active Core_VDD = 3.3 V PCI_VCC,+5V = 5V Clock = 0 MHz	tbd
HW Suspend PCI_CLK Stopped	High	Only interrupts and RI_OUT* available ^a PCI bus turned off ^b Core_VDD = 3.3 V +5V = 5V PCI_VCC = 0 V Clock = 0 MHz	tbd

^a The CL-PD6833 uses the CLKRUN mechanism to assert ISA IRQs. PCI interrupts (INTA# and/or INTB#) and RI_OUT* can be asserted while the PCI_CLK is stopped.

^b The CL-PD6833 tristates all PCI bus signals. REQ# is driven high on the PCI bus.

3.1.7 Socket Power Management Features

3.1.7.1 Socket Power Control

The CL-PD6833 provides two pins to serially control the socket power. These pins have multiple functionality to allow the CL-PD6833 to interface with a number of socket power-control chips. Following are the two socket power-control signalling modes supported by the CL-PD6833:

- Texas Instruments TPS2206AIDF Serial Signalling mode
- SMBus™ (system management bus)¹ Signalling mode using the Maxim 1601

The socket power-control signalling mode is usually established during power-on reset by the level of pins 131 (SDATA/SMBDATA) and 130 (SLATCH/SMBCLK), but it can also be set by writing to bit 2 of the **Misc Control 3** register. Refer to [Table 3-5](#) for the configuration of the power-control signalling mode.

Table 3-5. Socket Power Control Configuration

Socket Power Signalling Mode	SLATCH/SMBCLK (Pin 130)	Misc Control 3 Bit 2
Texas Instruments TPS2206AIDF or External Hardware Serial Mode	Pull-down	0
SMBus (system management bus)	Pull-up	1

Texas Instruments TPS2206AIDF Serial Signalling Mode

In this mode, the CL-PD6833 can interface with the Texas Instruments TPS2206AIDF dual-socket PC Card power interface switch, which uses a three-pin interface: SCLK, SDATA, and SLATCH (refer to [Figure 3-10](#)). The pin SCLK is connected to the 10–100-kHz (usually 32-kHz) clock typically available on the system. This serves as a reference clock for the CL-PD6833 and as a clock to the TPS2206AIDF. The data is serially transferred over SDATA and the latch signal is SLATCH.

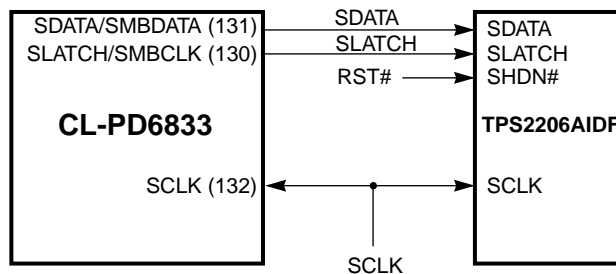


Figure 3-10. Power Control Using Texas Instruments TPS2206AIDF Serial Signalling Mode

¹ SMBus is a trademark of Intel® Corporation.

External-Hardware Serial Signalling Mode

In this mode, the CL-PD6701 is used to establish a parallel power-control interface (refer to [Figure 3-11](#)). This mode enables the use of parallel socket power control chips.

NOTE: In the CL-PD6833, this mode is currently the same as Texas Instruments TPS2206AIDF Serial Signalling mode.

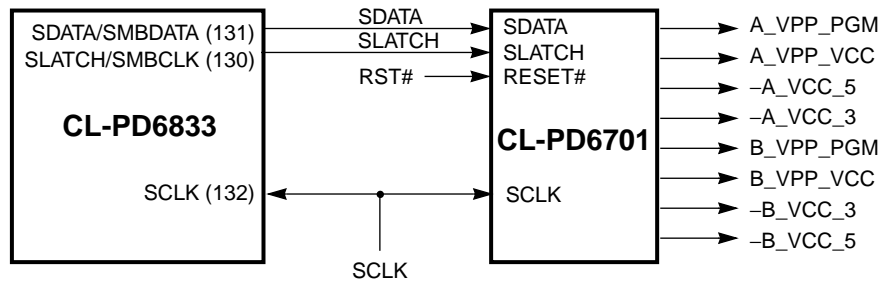


Figure 3-11. Power Control Using External-Hardware Signalling Mode

System Management Bus Signalling Mode

In this mode, the CL-PD6833 supports the Intel[®] SMBus (system management bus) protocol, which uses a two-pin interface: SMBDATA and SMBCLK (refer to [Figure 3-12](#)). The system management bus is a subset of the I²C bus. The serial data is available on the SMBDATA pin and the serial clock is on the SMBCLK pin. The SCLK pin is used as a reference clock for the CL-PD6833. The Maxim MAX1601 dual-channel PC Card V_{CC}/V_{PP} power-switching network supports the SMBus protocol. The PCI bus reset signal can be used to reset the MAX1601 chip.

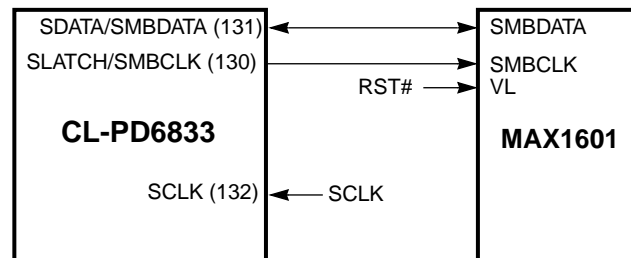


Figure 3-12. Power Control Using SMBus Signalling Mode

3.1.7.2 Card Removal

When a card is removed from a socket, the CL-PD6833 automatically disables the V_{CC} and V_{PP} supplies to the socket. The CL-PD6833 can also be configured to have management interrupts notify software of card removal.

3.1.7.3 Card Insertion

Power to the socket is off at reset and whenever there is no card in a socket. When a card is detected (card detect input pins, CD1# and CD2#, to the CL-PD6833 become asserted low), power is applied by software after sensing card insertion. Card insertion is sensed by allowing any change in state on the CD2# and CD1# pins to generate a management interrupt.

3.1.8 Bus Sizing

The CL-PD6833 supports 32-bit transactions on the PCI bus while supporting 8- or 16-bit PC Cards.

3.1.9 Programmable PC Card Timing

The CL-PD6833 can be programmed to match the timing requirements of any PC Card. The memory command signals (WE#, OE#) and I/O command signals (IOWR#, IORD#) at the PC Card interface have three phases: setup, command, and recovery. These three phases are programmed by the timing registers on a per socket basis. There are two sets of timing registers, **Timer Set 0** and **Timer Set 1**, which can be selected on a per-window basis for both I/O and memory windows.

3.1.10 ATA Mode Operation

The CL-PD6833 supports direct connection to ATA hard drives when in PC Card 16 mode. ATA drives use an interface very similar to the IDE interface found on many popular portable computers.

3.1.11 PC Card Sensing

The CL-PD6833 provides sensing capabilities for all types of cards and voltages compliant with the PC Card Specification. This includes the following card types:

- PC Card 16 (R2) at 5.0 or 3.3 V
- PC Card 32 (CardBus) at 3.3 V

The pins CD2#, CD1#, VS2, and VS1 are used to sense the types and operating voltages of inserted cards, as shown in [Table 3-6](#). The x.x and y.y operating voltages are detected and reflected in the **Present State** register (memory offset 008h). Values of these voltages are not yet defined by the PC Card Specification. The CL-PD6833 assumes a low-voltage key (CardBus-capable socket in system). After PC Card insertion, card type and voltage information is available in the **Socket Present State** register.

Table 3-6. Card Detect and Voltage Sense

CD2#/CCD2#	CD1#/CCD1#	VS2/CVS2	VS1/CVS1	Card Type	Voltage (V)
GND	GND	Open	Open	PC Card 16	5.0
GND	GND	GND	GND	PC Card 16	3.3/x.x
GND	CVS1	Open	CCD1#	PC Card 32	3.3
CVS2	GND	CCD2#	GND	PC Card 32	3.3/x.x
CVS1	GND	GND	CCD2#	PC Card 32	3.3/x.x/y.y
GND	GND	GND	Open	PC Card 16	x.x
CVS2	GND	CCD2#	Open	PC Card 32	x.x
GND	CVS2	CCD1#	Open	PC Card 32	x.x/y.y
CVS1	GND	Open	CCD2#	PC Card 32	y.y
GND	CVS1	GND	CCD1#	Reserved	Reserved
GND	CVS2	CCD1#	GND	Reserved	Reserved

3.2 Upgrading from the CL-PD6832 to the CL-PD6833

The CL-PD6833 is a direct pin replacement for the CL-PD6832. The CL-PD6833 has support for ACPI and GPIO pins to control the external buffers for ZV (zoomed video) port. These features have to be considered when designing a board that can accept the CL-PD6832 or the CL-PD6833 in the same footprint.

Table 3-7 depicts the essence of upgrading. The register bits in Table 3-7 are part of the PME_CXT (PME Context). They do not get reset or initialized if PME enable is true when the CL-PD6833 changes power states from D3 to D0 through a software PCI bus segment reset.

Table 3-7. Upgrading from the CL-PD6832 to the CL-PD6833

Pin Number	CL-PD6832-Only Function	CL-PD6833 Function / Bit Values	CL-PD6833 Function / Bit Values	Register / Bits
128	SPKR_OUT*		GPIO3/01	914h / 5:4
133	LEDOUT*/HW_SUSPEND#	PME#/10	GPIO4/01	914h / 7:6
203	INTA#	LED1*	GPIO1/01	914h / 1:0
204	INTB#/RI_OUT*	PME#/10		915h / 1:0
206	SIN#/ISDAT	LED2*	GPIO2/01	914h / 3:2

The CL-PD6833 powers up in a default state with CL-PD6832 functionality. The only exception is pin 131. For ACPI compliance, the board has to be designed so that during the period before POWERGOOD goes true, pin 131 is held low while PCI_RST# is asserted low. During all other times, this pin behaves as SDATA/SMBDATA output. The following example circuit can be used to provide the PCI_RST# signal to pin 131 only when POWERGOOD is not true. When the POWERGOOD signal is not active, the FET

conducts and connects PCI_RST# to pin 131. During this time, the CL-PD6833 internally ensures that pin 131 is an input. Thereafter, when POWERGOOD is active, pins 131 and 207 are disconnected since the FET is not conducting. Pin 131 can then become an output and drive either SDATA or SMBDATA.

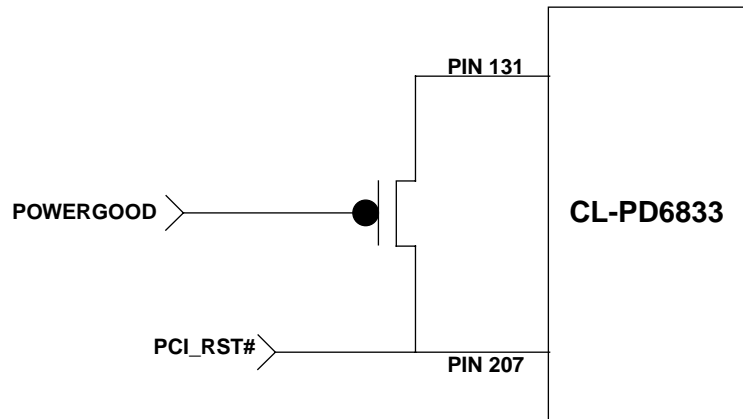


Figure 3-13. Power-on Detection for Power Management

Table 3-7 shows that after power-up, if registers 914h and 915h are programmed correctly, the CL-PD6833 provides the PME# signal for ACPI compliance and/or provides the GPIO signals for ZV port buffers. As shown in Table 3-7, PME# is available either on pin 133 or pin 204. Any illegal values (values other than the ones shown in Table 3-7) programmed in these registers provide default CL-PD6832 pin functionality for the corresponding bits.

Additional features of the CL-PD6833 are:

- In PCI Configuration Space, register 98h (see Configuration Miscellaneous 1 on page 73)
 - bit 2 enables the PCI interrupts (INTA#, INTB#, ...) in the PCI/Way data stream.
 - bit 8, when set to '1' locks registers 914h and 915h.
 - bit 9, when set to '1' disables the Read Prefetch.
 - bit 10, when set to '1' disables Auto PC Card Reset during power state D3. This is a power saving feature.

3.2.1 Added Registers

The following registers have been added to the PCI Configuration space.

NOTE: PME_CXT (PME Context) is a set of register bits that do not get reset or initialized if PME Enable is true when the CL-PD6833 changes power states from D3 to D0 through a software PCI Bus Segment reset.

3.2.1.1 Pin Multiplex Control 0 Register — PME_CXT

Register Name: Pin Multiplex Control 0 Register				PCI Memory Address: 914h			
Bit 7	Bit 6	Bit 5	Bit 4	Bit 3	Bit 2	Bit 1	Bit 0
LED_OUT*/ HW_SUSP*/ PME#/GPIO4 Sel 1	LED_OUT*/ HW_SUSP*/ PME#/GPIO4 Sel 0	SPKR_OUT*/ GPIO3/ Sel 1	SPKR_OUT*/ GPIO3/ Sel 0	SIN#/ISDAT/ LED2*/GPIO2 Sel 1	SIN#/ISDAT/ LED2*/GPIO2 Sel 0	INTA#/LED1*/ GPIO1 Sel 1	INTA#/LED1*/ GPIO1 Sel 0
R/W:0	R/W:0	R/W:0	R/W:0	R/W:0	R/W:0	R/W:0	R/W:0

Bits 1:0 — Pin 203 INTA#/LED1*/GPIO1 Pin Function Select

Bit 1	Bit 0	Pin Function
0	0	INTA# or LED1* ^a
0	1	GPIO1
1	0	Do not program this value.
1	1	Do not program this value.

^a The socket A LED indicator, active-low OD, or LED_OUT* if dual socket = 0.

Bits 3:2 — Pin 206, SIN#/ISDAT/LED2*/GPIO2 Pin Function Select

Bit 3	Bit 2	Pin Function
0	0	SIN#, ISDAT, or LED2* with control of pin characteristics per the CL-PD6832 bits. ^a
0	1	GPIO2
1	0	Do not program this value.
1	1	Do not program this value.

^a The socket B LED indicator, active-low OD, or LED_OUT* if configured for one LED (dual socket = 0).

Bits 5:4 — Pin 128, SPKR_OUT*/GPIO3 Pin Function Select

Bit 5	Bit 4	Pin Function
0	0	SPKR_OUT* with control of pin characteristics per the CL-PD6832.
0	1	GPIO3
1	0	Do not program this value.
1	1	Do not program this value.

Bits 7:6 — Pin 133, LED_OUT*/HW_SUSP*/PME#/GPIO4 Pin Function Select

Bit 7	Bit 6	Pin Function
0	0	LED_OUT* or HW_SUSP* with control of pin characteristics per the CL-PD6832.
0	1	GPIO4
1	0	PME# as defined by PCI specification (PCI power management add-on specification).
1	1	Do not program this value.

3.2.1.2 Pin Multiplex Control 1 Register — PME_CXT

<i>Register Name: Pin Multiplex Control 1 Register</i>						<i>PCI Memory Address: 915h</i>	
<i>Bit 7</i>	<i>Bit 6</i>	<i>Bit 5</i>	<i>Bit 4</i>	<i>Bit 3</i>	<i>Bit 2</i>	<i>Bit 1</i>	<i>Bit 0</i>
		RFU				INTB#/ RI_OUT*/ PME# Sel 1	INTB#/ RI_OUT*/ PME# Sel 0
		R/W:0				R/W:0	R/W:0

Bits 1:0 — Pin 204, INTB#/RI_OUT*/ PME# Pin Function Select

Bit 1	Bit 0	Pin Function
0	0	INTB# or RI_OUT*, using existing CL-PD6832 select bits.
0	1	Do not program this value.
1	0	PME# as defined by PCI specification (PCI power management add-on specification).
1	1	Do not program this value.

Bits 7:2 — Reserved for future use

3.3 Host Access to Registers

The CL-PD6833 CardBus registers can be accessed in Memory-Mapped mode only. Other CL-PD6833 registers can be accessed either in Memory-Mapped mode or I/O-Mapped mode. To access registers in Memory-Mapped mode, program the CL-PD6833 memory base address offset 10h in the configuration space. To access registers in I/O-Mapped mode, program offset 44h in the configuration space accordingly. In I/O-Mapped mode, the CL-PD6833 registers are accessed through an 8-bit indexing mechanism. An **Index** register scheme allows a large number of internal registers to be accessed by the CPU using only two I/O addresses.

The **Index** register (see Chapter 7, "OPERATION REGISTERS") is used to specify which of the internal registers the CPU accesses next. The value in the **Index** register is called the Register Index and is the number that specifies a unique internal register. The **Data** register is used by the CPU to read and write the internal register specified by the **Index** register.

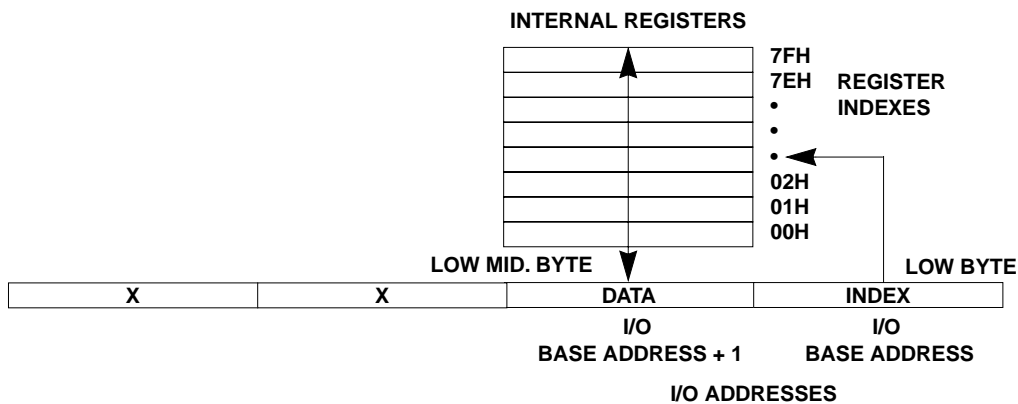


Figure 3-14. Indexed 8-Bit Register Structure

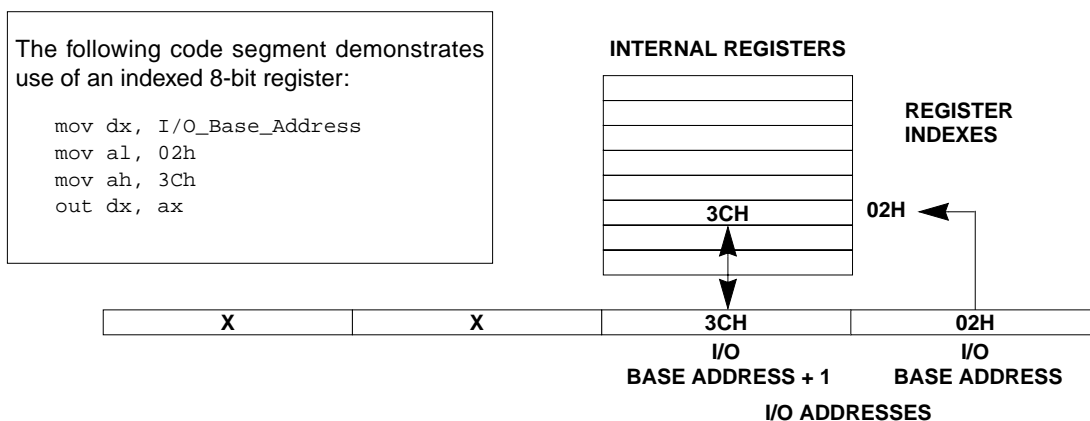


Figure 3-15. Indexed 8-Bit Register Example

The CL-PD6833 has **Extension** registers that add to the functionality of the 82365SL-compatible register set. Within the **Extension** registers is an **Extended Index** register and **Extended Data** register that provide access to more registers. The registers accessed through **Extended Index** and **Extended Data** are thus double-indexed. The example below shows how to access the **Extension Control 1** register, one of the double-indexed registers.

```
;Write to Extension Control 1 register example

;Constants section
Extended_Index EQU 2Eh
Index_Reg      EQU 2Fh
Ext_Cntrl_1    EQU 03h
I/O_Base_Address EQU XXX
                ;The base I/O address for the CL-PD6833
                ;should be obtained through PCI BIOS.

;Code section
mov dx, I/O_Base_Address
mov al, Extended_Index
mov ah, Ext_Cntrl_1
out dx, ax
mov al, Index_Reg
mov ah, user_data ;Desired data to be
out dx, ax        ;written to
                  ;extended index 03h

;Read from Extension Control 1 register example

;Code section
mov dx, I/O_Base_Address
mov al, Extended_Index
mov ah, Ext_Cntrl_1
out dx, ax
mov al, Index_Reg
out dx, al
inc dx        ;al has extended
in al, dx    ;index 03h data
```

The following software code shows a sample of how to access the CL-PD6833 in Memory-Mapped mode.

```
; assume ES Selector points to base address
; 8-bit read access example
mov EBx, 804h
mov al, ES:[BX]

; 16-bit read access example
mov ax, ES: [BX]

; 32-bit read access example
mov Eax, ES: [BX]

; 8-bit write access example
mov al, 6H
MOV ES: [BX], al

; 16-bit write access example
mov ax, 0806h
MOV ES: [BX], ax

; 32-bit write access example
MOV Eax, 090A1206h
MOV ES: [BX], eax
```

3.4 Power-On Setup

Following RST#-activated reset, the CL-PD6833 must be configured by host initialization or BIOS software. The application of the RST# signal on power-up causes initialization of all the CL-PD6833 register bits and fields to their reset values.

4. REGISTER DESCRIPTION CONVENTIONS

Register Headings

The description of each register starts with a header containing the following information:

Header Field	Description
Register Name	This indicates the register name.
Offset	This is added to the base address to generate the total effective address.
Register Per	This indicates whether the register affects both sockets, marked <i>chip</i> , or an individual socket, marked <i>socket</i> . If <i>socket</i> is indicated, there are two registers being described, each with a separate index value (one for each socket, A and B). ^a
Index ^a	This is the index value through which an internal register in an indexed register set is accessed in I/O mode.
Register Compatibility Type	This indicates whether the register is 82365SL-compatible, marked <i>365</i> ; a register extension, marked <i>ext.</i> ; or DMA-compatible for PCI/Way, marked <i>DMA</i> .

^a When the register is socket-specific, the Index value given in the register heading is for Socket A only. For the Socket B register, add 40h to the index value of the Socket A register to obtain the I/O address. The memory address of any socket register is an offset from the memory base address of the configuration space for that socket.

Special Function Bits

Following is a description of bits with special functions:

Bit Type	Description
0 or 1	These read-only bits are forced to either '0' or '1' at reset and cannot be changed.
Compatibility Bit	These bits have no function on the CL-PD6833, but are included for compatibility with the 82365SL register set.
PCI/Way	These bits provide the programming model for the PCI/Way DMA support.
PME_CXT (PME Context)	PME Context is a set of bits that do not get reset or initialized if PME Enable is true when the CL-PD6833 changes power states from D3 to D0 through a software PCI Bus Segment reset.
Reserved	These bits are reserved and should not be changed.
Scratchpad Bit	These read/write bits are available for use as bits of memory.
Sticky Bit	This is a read-only bit and must be cleared by writing a '1' to it.

Bit Naming Conventions

The following keywords are used within bit and field names:

Keyword	Description
Enable	Indicates that the function described in the rest of the bit name is active when the bit is '1'.
Disable	Indicates that the function described in the rest of the bit name is active when the bit is '0'.
Mode	Indicates that the bit alters the interpretation of the values in other registers.
Input	Indicates a bit or field that is read from a pin.
Output	Indicates a bit or field that is driven to a pin.

Bit Naming Conventions (cont.)

The following keywords are used within bit and field names:

Keyword	Description
Select	Indicates that the bit or field selects between multiple alternatives. Fields that contain <i>Select</i> in their names have an indirect mapping between the value of the field and the effect.
Status	Indicates one of two types of bits: either read-only bits used by the CL-PD6833 to report information to the system or bits set by the CL-PD6833 in response to an event that can also be cleared by the system. The system cannot directly cause a Status bit to become '1'.
Value	Indicates that the bit or field value is used as a number.

Register Bit Types

Type	Description
C	Clearable by writing a '1' to the bit
R	Readable
W	Writable

5. PCI CONFIGURATION REGISTERS

The CL-PD6833 has two **PCI Configuration** register sets. Each of these register sets corresponds to a socket. The second socket is the second function and starts at 100h. These register sets occupy configuration offsets 00h–4Fh. The register sets vary only in the function number (see *PCI Bus Specification*, Rev. 2.1 for further information). They control basic PCI bus functionality. **PCMCIA Operation** registers are accessed through either the **Memory Base Address** register or the **I/O Base Address** register. The registers in this section are specific to each socket.

Table 5-1. PCI Configuration Registers Quick Reference

Register Name	Memory Offset	Page Number
Vendor ID and Device ID (Device ID = 1113h and Vendor ID = 1013h)	00h	48
Command and Status	04h	49
Revision ID and Class Code (Revision ID = '11100001' and Class Code = 060700h)	08h	52
Cache Line Size, Latency Timer, Header Type, and BIST (Cache Line Size = 00h, Header Type = 82h, and BIST = 0h)	0Ch	53
Memory Base Address	10h	54
CardBus Status	14h	55
PCI Bus Number, CardBus Number, Subordinate Bus Number, and CardBus Latency Timer	18h	57
Memory Base 0–1	1Ch, 24h	58
Memory Limit 0–1	20h, 28h	59
I/O Base 0–1	2Ch, 34h	60
I/O Limit 0–1	30h, 38h	61
Interrupt Line, Interrupt Pin, and Bridge Control	3Ch	62
Subsystem Vendor ID and Subsystem Device ID	40h	65
PC Card 16-Bit IF Legacy Mode Base Address	44h	66
Reserved	48h–7Fh	—
Power Management Registers	80h	67
Power Management Control and Status	84h	68
DMA Slave Configuration Register	90h	70
Socket Number	94h	71
Configuration Miscellaneous 1	98h	73

5.1 Vendor ID and Device ID

Register Name: Vendor ID and Device ID		Register Per: chip	
Offset: 00h			
Byte 3 Device ID (high)	Bit 31 Bit 30 Bit 29 Bit 28 Bit 27 Bit 26 Bit 25 Bit 24	Device ID (high)	
		R:00010001	
Byte 2 Device ID (low)	Bit 23 Bit 22 Bit 21 Bit 20 Bit 19 Bit 18 Bit 17 Bit 16	Device ID (low)	
		R:00010011	
Byte 1 Vendor ID (high)	Bit 15 Bit 14 Bit 13 Bit 12 Bit 11 Bit 10 Bit 9 Bit 8	Vendor ID (high)	
		R:00010000	
Byte 0 Vendor ID (low)	Bit 7 Bit 6 Bit 5 Bit 4 Bit 3 Bit 2 Bit 1 Bit 0	Vendor ID (low)	
		R:00010011	

Bits 15:0 — Vendor ID

This read-only field is the vendor identification assigned to Cirrus Logic by the PCI Special Interest Group. This field always reads back 1013h.

Bits 31:16 — Device ID

This read-only field is the device identification assigned to this device by Cirrus Logic. This field always reads back 1113h for the CL-PD6833. (Revision number identification for the CL-PD6833 part itself is indicated by the Revision ID field in the **Revision ID and Class Code** register at configuration offset 08h.)

5.2 Command and Status

		Register Name: Command and Status						Register Per: socket	
		Offset: 04h							
Byte 3 Status (high)	Bit 31	Bit 30	Bit 29	Bit 28	Bit 27	Bit 26	Bit 25	Bit 24	
	Address/Data Parity Error Detected RC:0	System Error (SERR#) Generated RC:0	Received Master Abort RC:0	Received Target Abort RC:0	Signalled Target Abort RC:0	DEVSEL# Timing R:01		Master Data Parity Error Reported RC:0	
Byte 2 Status (low)	Bit 23	Bit 22	Bit 21	Bit 20	Bit 19	Bit 18	Bit 17	Bit 16	
	Fast Back-to-Back Capable R:0	UDF Supported R:0	66-MHz Supported R:0	New Capabilities Present R:1	Reserved R:0000				
Byte 1 Command (high)	Bit 15	Bit 14	Bit 13	Bit 12	Bit 11	Bit 10	Bit 9	Bit 8	
	Reserved R:0000000							System Error (SERR#) Enable R/W:0	
Byte 0 Command (low)	Bit 7	Bit 6	Bit 5	Bit 4	Bit 3	Bit 2	Bit 1	Bit 0	
	Wait Cycle Control R:0	Parity Error Check/Report Enable R/W:0	Reserved R:0	Memory Write and Invalidate Enable R:0	Special Cycle Enable R:0	Bus Master Enable R/W:0	PCI Memory Space Enable R/W:0	PCI I/O Space Enable R/W:0	

Bit 0 — PCI I/O Space Enable

This bit does not affect R2 I/O space.

0	If this bit is '0' for both Sockets A and B, any reads or writes to the I/O registers of the CL-PD6833 are ignored. If this bit is a '1', I/O accesses to the registers or CardBus card are carried out. For configuration space 0, I/O accesses to both sockets are disabled.
1	The I/O space for the CL-PD6833 is enabled and responds to the reads and writes to the I/O address range defined in I/O Base Address register as well as any I/O window addresses. For configuration space 0, this bit enables I/O register accesses for both Sockets A and B.

Bit 1 — PCI Memory Space Enable

This bit must be set for the CL-PD6833 to respond to memory transactions. This bit does not affect R2 memory space.

0	The memory space for the CL-PD6833 is disabled. Any reads or writes to the CL-PD6833 memory space are ignored.
1	The memory space for the CL-PD6833 is enabled, allowing access to memory window and memory-mapped CL-PD6833 registers.

Bit 2 — Bus Master Enable

This bit must be set to enable the bus master capability in the CL-PD6833.

0	Bus master capability disabled.
1	Bus master capability enabled.

Bit 3 — Special Cycle Enable

This bit reads back a '0', since a PCI-to-PCI bridge cannot respond to special cycle transactions as a target.

Bit 4 — Memory Write and Invalidate Enable

This bit reads back a '0', since a PCI-to-PCI bridge cannot initiate a memory write and invalidate command.

Bit 5 — Reserved
Bit 6 — Parity Error Check/Report Enable

This bit enables data parity-reporting-related circuitry, except for bit 31 of this register.

0	Data parity checking and reporting is disabled.
1	Data parity checking and reporting is enabled.

Bit 7 — Wait Cycle Control

This bit always reads '0', indicating that the CL-PD6833 does not employ address or data stepping.

Bit 8 — System Error (SERR#) Enable

This bit enables the CL-PD6833 to report system errors by asserting the SERR# pin when address parity errors occur. Bit 6 must also be set to '1' to allow a data parity error to cause SERR# activation. See also the description of bit 30 in this register.

0	Activation of SERR# on address parity error is disabled.
1	SERR# is activated whenever an address parity error is internally detected (slave mode).

Bits 19:9 — Reserved
Bit 20 — New Capabilities Present

A '1' in this location indicates new capabilities in its configuration space (CardBus Controller and Power Management capabilities). The **CardBus Status** register (offset 14h) is a pointer for these capabilities. It defines the locations of the registers described under the new capabilities function.

Bits 23:21 — Fast Back-to-Back Capable, UDF Supported, and 66-MHz Supported

All of these features are not supported and read back '0's.

Bit 24 — Master Data Parity Error Reported

This bit is set when a parity error is generated or detected, bit 6 of this register is set, and the CL-PD6833 is acting as a bus master. To clear this bit, software must write a '1' to it.

Bits 26:25 — DEVSEL# Timing

This field always reads back '01', identifying the CL-PD6833 as a medium-speed device.

Bit 27 — Signalled Target Abort

To clear this bit, software must write a '1' to it.

0	No target device has signalled a target abort.
1	A target device has signalled a target abort.

Bit 28 — Received Target Abort

To clear this bit, software must write a '1' to it.

0	No master transaction has been terminated with a target abort.
1	A master transaction has been terminated with a target abort.

Bit 29 — Received Master Abort

To clear this bit, software must write a '1' to it.

0	No transaction has been terminated due to master abort.
1	A master device has terminated its transaction with master abort.

Bit 30 — System Error (SERR#) Generated

This bit is set whenever the CL-PD6833 asserts SERR# because of internal detection of a PCI address parity error. Bit 8 of this register must be set before system errors can be reported, and bit 6 must be set to allow address parity errors to be detected. The CL-PD6833 only asserts SERR# if address parity errors occur. To clear this bit, software must write a '1' to it.

0	SERR# was not asserted by this device.
1	SERR# was asserted by this device, indicating a PCI address parity error.

Bit 31 — Address/Data Parity Error Detected

This bit indicates whether a parity error was detected, independent of whether bit 6 of this register is '1'. To clear this bit, software must write a '1' to it.

0	No data parity errors detected.
1	Address or data parity error detected.

5.4 Cache Line Size, Latency Timer, Header Type, and BIST

Register Name: Cache Line Size, Latency Timer, Header Type, and BIST		Register Per: socket					
Offset: 0Ch							
Bit 31	Bit 30	Bit 29	Bit 28	Bit 27	Bit 26	Bit 25	Bit 24
Byte 3 BIST		BIST		R:00000000			
Bit 23	Bit 22	Bit 21	Bit 20	Bit 19	Bit 18	Bit 17	Bit 16
Byte 2 Header Type		Header Type		R:10000010			
Bit 15	Bit 14	Bit 13	Bit 12	Bit 11	Bit 10	Bit 9	Bit 8
Byte 1 Latency Timer		Latency Timer 7:3		R/W:00000		Latency Timer 2:0	
Bit 7	Bit 6	Bit 5	Bit 4	Bit 3	Bit 2	Bit 1	Bit 0
Byte 0 Cache Line Size		Cache Line Size		R:00000000			

Bits 7:0 — Cache Line Size

This read-only field is always 00h, indicating that the CL-PD6833 does not participate in PCI-defined caching algorithms, and only generates memory write invalidate as a result of a PC Card 32 master cycle.

Bits 15:8 — Latency Timer 7:0

This field programs the master latency time-out value. If the full byte is available, the latency timer programs in increments of one PCI clock (PCI_CLK), but because bits 10:8 on the CL-PD6833 are read-only and must be programmed to 0h, master latency time-out values are programmable in increments of eight PCI clocks.

Bits 23:16 — Header Type

This read-only field is always 82h, specifying that the CL-PD6833 is a multi-function PCI-to-CardBus bridge.

Bits 31:24 — BIST

This read-only field is reserved for BIST information. If this field returns all '0's on a read, then this device does not contain a BIST.

5.5 Memory Base Address

Register Name: Memory Base Address		Register Per: socket						
Offset: 10h								
Byte 3	Bit 31	Bit 30	Bit 29	Bit 28	Bit 27	Bit 26	Bit 25	Bit 24
	Controller Memory Base Address (high)							
R/W:00000000								
Byte 2	Bit 23	Bit 22	Bit 21	Bit 20	Bit 19	Bit 18	Bit 17	Bit 16
	Controller Memory Base Address (high mid.)							
R/W:00000000								
Byte 1	Bit 15	Bit 14	Bit 13	Bit 12	Bit 11	Bit 10	Bit 9	Bit 8
	Controller Memory Base Address (low mid.)				Controller Memory Base Address (low mid.)			
R/W:0000				R:0000				
Byte 0	Bit 7	Bit 6	Bit 5	Bit 4	Bit 3	Bit 2	Bit 1	Bit 0
	Controller Memory Base Address (low)				Prefetchable	Type		Memory Space Indicator
R:0000				R:0	R:00		R:0	

This is the PCI memory address space base address for the **Operation** registers.

Bit 0 — Memory Space Indicator

This bit always reads back '0', indicating that this base address register defines a PCI memory space.

Bits 2:1 — Type

These bits indicate that the controller can be located anywhere in the 32-bit address space.

Bit 3 — Prefetchable

This bit indicates that the **Controller** registers are not prefetchable.

Bits 31:4 — Controller Memory Base Address

This field specifies the memory-mapped register space of the CL-PD6833. The **Operation** registers can be accessed through this window only after these bits are set to a non-zero value.

5.6 CardBus Status

Register Name: CardBus Status		Register Per: socket						
Offset: 14h								
Byte 3 CardBus Status (high)	Bit 31 Address/Data Parity Error Detected RC:0	Bit 30 Received System Error (SERR#) RC:0	Bit 29 Received Master Abort RC:0	Bit 28 Received Target Abort RC:0	Bit 27 Signalled Target Abort RC:0	Bit 26 Reserved R:00	Bit 25 Reserved	Bit 24 Secondary Bus Data Parity Error Reported RC:0
	Reserved							
Byte 2 CardBus Status (low)	Reserved							
	R:00000000							
Byte 1	Reserved							
	R:00000000							
Byte 0	Power Capabilities Pointer							
	R:10000000							

NOTE: The CardBus (Secondary) Status bytes are similar to the Status bytes in the **Command and Status** register, but contain information relating to the CardBus. Bit 30 is defined differently than in the **Command and Status** register. These bits are reset by PCI reset and by writing '1' to the bit.

Bits 7:0 — Power Capabilities Pointer

This value indicates that the **CardBus Controller Power Management** registers begin at offset 80h in this configuration space.

Bits 23:8 — Reserved

Bit 24 — Secondary Bus Data Parity Error Reported

This bit is used to report the receipt of PERR# on the PC Card 32 bus. Write a '1' to this bit to clear it.

Bits 26:25 — Reserved

Bit 27 — Signalled Target Abort

To clear this bit, software must write a '1' to it.

0	No target device has signalled a target abort.
1	A target device has signalled a target abort.

Bit 28 — Received Target Abort

To clear this bit, software must write a '1' to it.

0	No master transaction has been terminated with a target abort.
1	A master transaction has been terminated with a target abort.

Bit 29 — Received Master Abort

To clear this bit, software must write a '1' to it.

0	No transaction has been terminated due to master abort.
1	A master device has terminated its transaction with master abort.

Bit 30 — Received System Error (SERR#)

This bit is set whenever the CardBus interface detects an address parity error. Bit 17 of the **Interrupt Line, Interrupt Pin, and Bridge Control** register (memory offset 3Ch) must be set before system errors can be reported, and bit 16 of the **Interrupt Line, Interrupt Pin, and Bridge Control** register must be set to allow address parity errors to be detected. The CL-PD6833 only asserts SERR# if address parity errors occur. To clear this bit, software must write a '1' to it.

0	SERR# assertion on the CardBus interface has not been detected.
1	SERR# assertion on the CardBus interface has been detected.

Bit 31 — Address/Data Parity Error Detected

This bit indicates whether a parity error was detected, independent of whether bit 16 of the **Bridge Control** register (memory offset 3Ch) is '1'. To clear this bit, software must write a '1' to it.

0	No data parity errors detected.
1	Address or data parity error detected.

5.7 PCI Bus Number, CardBus Number, Subordinate Bus Number, and CardBus Latency Timer

		Register Name: PCI Bus Number, CardBus Number, Subordinate Bus Number, and CardBus Latency Timer						Register Per: socket	
		Offset: 18h							
		Bit 31	Bit 30	Bit 29	Bit 28	Bit 27	Bit 26	Bit 25	Bit 24
Byte 3 CardBus Latency Timer		CardBus Latency Timer 7:3					CardBus Latency Timer 2:0		
		R/W:00000					R:000		
Byte 2 Subordinate Bus Number		Bit 23	Bit 22	Bit 21	Bit 20	Bit 19	Bit 18	Bit 17	Bit 16
		Subordinate Bus Number							
		R/W:00000000							
Byte 1 CardBus Number		Bit 15	Bit 14	Bit 13	Bit 12	Bit 11	Bit 10	Bit 9	Bit 8
		CardBus Number							
		R/W:00000000							
Byte 0 PCI Bus Number		Bit 7	Bit 6	Bit 5	Bit 4	Bit 3	Bit 2	Bit 1	Bit 0
		PCI Bus Number							
		R/W:00000000							

Bits 7:0 — PCI Bus Number

This byte identifies the number of the PCI bus on the primary side of the bridge. This byte is set by PCI BIOS configuration software.

Bits 15:8 — CardBus Number

This byte identifies the number of the CardBus attached to the socket, and it is set by PCI BIOS configuration software or socket services.

Bits 23:16 — Subordinate Bus Number

This byte is defined for PCI-to-PCI bridges. It identifies the number of the bus at the lowest part of the hierarchy behind the bridge. Normally, a CardBus bridge is at the bottom of the bus hierarchy and this register holds the same value as the **CardBus Number** register.

Bits 31:24 — CardBus Latency Timer 7:0

This byte has the same functionality as the primary PCI Bus Latency Timer, but applies to the CardBus attached to this specific socket. This byte is set by PCI BIOS configuration software or socket services.

5.8 Memory Base 0–1

Register Name: Memory Base 0–1		Register Per: socket						
Offset: 1Ch, 24h								
Byte 3	Bit 31	Bit 30	Bit 29	Bit 28	Bit 27	Bit 26	Bit 25	Bit 24
	Memory Base 31:24 R/W:11111111							
Byte 2	Bit 23	Bit 22	Bit 21	Bit 20	Bit 19	Bit 18	Bit 17	Bit 16
	Memory Base 23:16 R/W:11111111							
Byte 1	Bit 15	Bit 14	Bit 13	Bit 12	Bit 11	Bit 10	Bit 9	Bit 8
	Memory Base 15:12 R/W:1111				Memory Base 11:8 R:0000			
Byte 0	Bit 7	Bit 6	Bit 5	Bit 4	Bit 3	Bit 2	Bit 1	Bit 0
	Memory Base 7:0 R:00000000							

NOTE: **Memory Base 0–1** and **Memory Limit 0–1** are enabled by bit 1 of the **Command and Status** register (memory offset 04h). To disable one window, set bits 31:12 to the limit of that window equal to or below the corresponding base address.

Bits 31:0 — Memory Base 31:0

This register defines the bottom address of a PCI memory window to be mapped to CardBus-capable PC Card memory space. The upper 20 bits correspond to PCI address bits AD[31:12]. The bottom 12 bits (which correspond to PCI address bits AD[11:0]) of this register are read-only and return '0' when read.

5.9 Memory Limit 0–1

Register Name: Memory Limit 0–1		Register Per: socket						
Offset: 20h, 28h								
Byte 3	Bit 31	Bit 30	Bit 29	Bit 28	Bit 27	Bit 26	Bit 25	Bit 24
	Memory Limit 31:24 R/W:00000000							
Byte 2	Bit 23	Bit 22	Bit 21	Bit 20	Bit 19	Bit 18	Bit 17	Bit 16
	Memory Limit 23:16 R/W:00000000							
Byte 1	Bit 15	Bit 14	Bit 13	Bit 12	Bit 11	Bit 10	Bit 9	Bit 8
	Memory Limit 15:12 R/W:0000				Memory Limit 11:8 R:0000			
Byte 0	Bit 7	Bit 6	Bit 5	Bit 4	Bit 3	Bit 2	Bit 1	Bit 0
	Memory Limit 7:0 R:00000000							

NOTE: **Memory Base 0–1** and **Memory Limit 0–1** are enabled by bit 1 of the **Command and Status** register (memory offset 04h). To disable one window, set bits 31:12 to the limit of that window equal to or below the corresponding base address.

Bits 31:0 — Memory Limit 31:0

This register defines the top address of a PCI memory window to be mapped to CardBus-capable PC Card memory space. The upper 20 bits correspond to PCI address bits AD[31:12]. The bottom 12 bits (which correspond to PCI address bits AD[11:0]) are read-only and return '0' when read; however, the bridge assumes PCI address bits AD[11:0] are '1's to determine the range defined, so if **Memory Base 0–1** and **Memory Limit 0–1** registers are set to the same value, a 4-Kbyte window is defined.

5.10 I/O Base 0–1

Register Name: I/O Base 0–1		Register Per: socket						
Offset: 2Ch, 34h								
Byte 3	Bit 31	Bit 30	Bit 29	Bit 28	Bit 27	Bit 26	Bit 25	Bit 24
	I/O Base 31:24 R:00000000							
Byte 2	Bit 23	Bit 22	Bit 21	Bit 20	Bit 19	Bit 18	Bit 17	Bit 16
	I/O Base 23:16 R:00000000							
Byte 1	Bit 15	Bit 14	Bit 13	Bit 12	Bit 11	Bit 10	Bit 9	Bit 8
	I/O Base 15:8 R/W:11111111							
Byte 0	Bit 7	Bit 6	Bit 5	Bit 4	Bit 3	Bit 2	Bit 1	Bit 0
	I/O Base 7:2 R/W:111111						I/O Space Indicator R:00	

Bits 1:0 — I/O Space Indicator 1:0

These bits are an extension to the **I/O Base** register and always read back '00'. The value '00' indicates that the CL-PD6833 supports 16-bit PCI I/O address decoding. As described in the *PCI-to-CardBus Register description specification*, this means I/O access intended for CardBus cards require PCI address bits 31:16 to be '0'.

Bits 15:2 — I/O Base 15:2

These bits define the bottom of an address range of a PCI I/O window to be mapped to a CardBus-capable PCI I/O space. These bits correspond to PCI I/O address bits 15:2.

Bits 31:16 — I/O Base 31:16

These bits read all '0's to be compatible with the CL-PD6832.

NOTE: **I/O Base 0–1** and **I/O Limit 0–1** registers are enabled by bit 0 of the **Command and Status** register. To disable one window, set the limit of that window below the base. For example, if I/O base is equal to I/O limit, the CL-PD6833 does doubleword I/O addressing.

5.11 I/O Limit 0–1

Register Name: I/O Limit 0–1								Register Per: socket		
Offset: 30h, 38h										
Byte 3	Bit 31	Bit 30	Bit 29	Bit 28	Bit 27	Bit 26	Bit 25	Bit 24		
	I/O Limit 31:24 R:00000000									
Byte 2	Bit 23	Bit 22	Bit 21	Bit 20	Bit 19	Bit 18	Bit 17	Bit 16		
	I/O Limit 23:16 R:00000000									
Byte 1	Bit 15	Bit 14	Bit 13	Bit 12	Bit 11	Bit 10	Bit 9	Bit 8		
	I/O Limit 15:8 R/W:00000000									
Byte 0	Bit 7	Bit 6	Bit 5	Bit 4	Bit 3	Bit 2	Bit 1	Bit 0		
	I/O Limit 7:2 R/W:000000							Reserved R:00		

Bits 1:0 — Reserved

These bits are reserved and always read back '00'.

Bits 15:2 — I/O Limit 15:2

These bits define the top of an address range of a PCI I/O window to be mapped to a CardBus-capable PCI I/O space. These bits correspond to PCI I/O address bits 15:2.

Bits 31:16 — I/O Limit 31:16

These bits read all '0's to be compatible with the CL-PD6832.

5.12 Interrupt Line, Interrupt Pin, and Bridge Control

Register Name: Interrupt Line, Interrupt Pin, and Bridge Control		Register Per: socket						
Offset: 3Ch								
Byte 3 Bridge Control (high)	Bit 31	Bit 30	Bit 29	Bit 28	Bit 27	Bit 26	Bit 25	Bit 24
	Reserved					Write Posting Enable	Memory 1 Prefetch Enable	Memory 0 Prefetch Enable
					R:00000			
Byte 2 Bridge Control (low)	Bit 23	Bit 22	Bit 21	Bit 20	Bit 19	Bit 18	Bit 17	Bit 16
	IREQ-INT Enable	CardBus Reset	Master Abort Mode	Reserved	VGA Enable	ISA Enable	CardBus System Error (SERR#) Enable	CardBus Parity Error Response Enable
	R/W:0	R/W:1	R/W:0	R:0	R:0	R:0	R/W:0	R/W:0
Byte 1 Interrupt Pin	Bit 15	Bit 14	Bit 13	Bit 12	Bit 11	Bit 10	Bit 9	Bit 8
	Interrupt Pin							
								R:00000001/00000010
Byte 0 Interrupt Line	Bit 7	Bit 6	Bit 5	Bit 4	Bit 3	Bit 2	Bit 1	Bit 0
	Interrupt Line							
								R/W:00000000

Bits 7:0 — Interrupt Line

This register is used by software to communicate the routing of the interrupts (INTA# for Socket A and INTB# for Socket B).

Bits 15:8 — Interrupt Pin

These read-only registers indicate that the CL-PD6833 requires one interrupt line per function (Socket A and Socket B) and that these lines are INTA# and INTB#.

Bit 16 — CardBus Parity Error Response Enable

This bit determines the response to parity errors on the CardBus interface.

0	Ignore address/data parity errors on the CardBus interface.
1	Enable parity error reporting and detection on the CardBus interface.

Bit 17 — CardBus System Error (SERR#) Enable

This bit controls the forwarding of the CardBus interface SERR# assertions to the primary interface.

0	Disable forwarding of CardBus interface SERR# to the primary interface.
1	Enable forwarding of CardBus interface SERR# to the primary interface.

Bit 18 — ISA Enable

This bit is not implemented.

Bit 19 — VGA Enable

This bit is not implemented.

Bit 20 — Reserved

Bit 21 — Master Abort Mode

This bit controls the behavior of the bridge when a master abort termination occurs on either interface while bridge is the master.

0	Do not report master aborts and return all ones (FFFFFFFFh) on reads and discard data on writes to the secondary master.
1	Report master aborts by signalling target abort, if possible, or by asserting SERR# if enabled.

Bit 22 — CardBus Reset

This bit forces a reset on the CardBus interface whenever it is set. The CardBus interface is also reset whenever the RST# of the primary interface is asserted. Note that when the CRST# pin on the CardBus interface is asserted (low), this *does not* mean the primary interface gets reset too.

Forcing a reset on the CardBus interface causes its configuration registers to reset to their default states.

0	The reset signal to the CardBus card is inactive (high).
1	The reset signal to the CardBus card is active (low).

Bit 23 — IREQ-INT Enable

This bit is used to control the routing of PC Card IREQ (or CIREQ for CardBus cards) interrupts to ISA IRQ or PCI INT pin. This is used only when the CL-PD6833 is programmed for non-PCI style interrupts.

When this bit is set to '1', PC Card IREQ (CIREQ) interrupts are routed to the ISA IRQ line (IRQ3, 4, 5, 7, 11, 12, 14, or 15) as indicated by the **Interrupt and General Control** register (memory offset 803h). When this bit is set to '0', PC Card IREQ (CIREQ) interrupts are routed to the INT pin indicated by the **Interrupt Pin** register (memory offset 3Dh): INTA# for Socket A and INTB# for Socket B. If the CL-PD6833 is programmed for Ring Indicate, then INTB# is used for ring out and INTA# is used for both Sockets A and B, that is, INTB# is not available for function interrupt routing.

0	PC Card interrupts are routed to the INTX# pin indicated by the Interrupt Pin register.
1	PC Card interrupts are routed to the ISA IRQ pin indicated by the Interrupt and General Control register.

Bit 24 — Memory 0 Prefetch Enable

This bit is not implemented.

0	Read Prefetching for memory window 0 is disabled.
1	Read Prefetching for memory window 0 is enabled.

Bit 25 — Memory 1 Prefetch Enable

This bit is not implemented.

0	Read Prefetching for memory window 1 is disabled.
1	Read Prefetching for memory window 0 is enabled.

Bit 26 — Write Posting Enable

This bit enables posting of write data to the socket. If this bit is not set, the bridge must drain any data in its buffers before accepting data for the socket. Each data word must then be accepted by the target before the bridge can accept the next one from the source master. The bridge must not release the source master until the last word is accepted by the target. Operating with write posting disabled inhibits system performance.

0	Write posting is disabled.
1	Write posting is enabled.

Bits 31:27 — Reserved

5.13 Subsystem Vendor ID and Subsystem Device ID

Register Name: Subsystem Vendor ID and Subsystem Device ID		Register Per: socket						
Offset: 40h								
Byte 3 Subsystem Device ID (high)	Bit 31	Bit 30	Bit 29	Bit 28	Bit 27	Bit 26	Bit 25	Bit 24
	Subsystem Device ID (high)							
R/W:00000000								
Byte 2 Subsystem Device ID (low)	Bit 23	Bit 22	Bit 21	Bit 20	Bit 19	Bit 18	Bit 17	Bit 16
	Subsystem Device ID (low)							
R/W:00000000								
Byte 1 Subsystem Vendor ID (high)	Bit 15	Bit 14	Bit 13	Bit 12	Bit 11	Bit 10	Bit 9	Bit 8
	Subsystem Vendor ID (high)							
R/W:00000000								
Byte 0 Subsystem Vendor ID (low)	Bit 7	Bit 6	Bit 5	Bit 4	Bit 3	Bit 2	Bit 1	Bit 0
	Subsystem Vendor ID (low)							
R/W:00000000								

Bits 15:0 — Subsystem Vendor ID

This field is the identification assigned to the subsystem vendor by the PCI Special Interest Group. It must be set by the software.

Bits 31:16 — Subsystem Device ID

This field is the device identification assigned by the subsystem vendor to its device. It must be set by the software.

NOTES:

- 1) After writing to this register, set the Subsystem Vendor ID Lock bit (register 98h, bit 0) to '0'.
- 2) If the Subsystem Vendor ID Lock bit is set, this register becomes read only and cannot be written to.

5.14 PC Card 16-Bit IF Legacy Mode Base Address

Register Name: PC Card 16-Bit IF Legacy Mode Base Address		Register Per: chip	
Offset: 44h			
Byte 3	Bit 31 Bit 30 Bit 29 Bit 28 Bit 27 Bit 26 Bit 25 Bit 24	Controller I/O Base Address (high)	
		R/W:00000000	
Byte 2	Bit 23 Bit 22 Bit 21 Bit 20 Bit 19 Bit 18 Bit 17 Bit 16	Controller I/O Base Address (high mid.)	
		R/W:00000000	
Byte 1	Bit 15 Bit 14 Bit 13 Bit 12 Bit 11 Bit 10 Bit 9 Bit 8	Controller I/O Base Address (low mid.)	
		R/W:00000000	
Byte 0	Bit 7 Bit 6 Bit 5 Bit 4 Bit 3 Bit 2 Bit 1 Bit 0	Controller I/O Base Address (low)	I/O Space Indicator
		R/W:000000	R:01

This is the PCI I/O space base address for the **Operation** registers.

Bits 1:0 — I/O Space Indicator

These bits always read back '01', indicating that this **Base Address** register defines a PCI I/O space.

Bits 31:2 — Controller I/O Base Address

This field specifies the I/O-mapped register space of the CL-PD6833. The **Operation** registers can be accessed through this window only after these bits are set to a non-zero value. The allowable range is anywhere in the I/O map. For legacy software, this register should be set to '000003E1h'.

5.15 Power Management Registers

Register Name: Power Management Registers								Register Per: socket
Offset: 80h								
Byte 3	Bit 31	Bit 30	Bit 29	Bit 28	Bit 27	Bit 26	Bit 25	Bit 24
	PME# from D3 cold R:1	PME# from D3 hot R:1	PME# from D2 R:1	PME# from D1 R:1	PME# from D0 R:1	D2 support R:1	D1 support R:1	Dynamic Data support R:0
Byte 2	Bit 23	Bit 22	Bit 21	Bit 20	Bit 19	Bit 18	Bit 17	Bit 16
	Reserved R:0		Device Specific Initialization R:0	Aux Power Source R:1	PME Clock R:0	PCI Power Management Revision R:001		
Byte 1	Bit 15	Bit 14	Bit 13	Bit 12	Bit 11	Bit 10	Bit 9	Bit 8
	Next Item Pointer R:00000000							
Byte 0	Bit 7	Bit 6	Bit 5	Bit 4	Bit 3	Bit 2	Bit 1	Bit 0
	Capabilities ID R:00000001							

Bits 7:0 — Capabilities ID

This register identifies the rest of the registers in this section as a power management structure.

Bits 15:8 — Next Item Pointer

This register indicates that this section is the last of the capabilities structures.

Bits 18:16 — PCI Power Management Revision

The value '001' indicates that the CL-PD6833 complies with version 1.0 of the *PCI Power Management Interface Specification*.

Bits 31:19 — Power Management Capabilities

These bits indicate the following:

PME# can be asserted in power management state D0, D1, D2, and D3_{sw}.

This device supports power management state D1 and D2.

This device does not require a full speed clock to operate.

This bridge is capable of Dynamic Clock Control and supports the CLK_RUN# protocol.

This device does not require device specific software prior to use.

This device is compliant with version 1.0 of the *PCI Power Management Interface Specification*.

5.16 Power Management Control and Status

Register Name: Power Management Control and Status		Register Per: socket						
Offset: 84h								
Byte 3	Bit 31	Bit 30	Bit 29	Bit 28	Bit 27	Bit 26	Bit 25	Bit 24
	Data R:00000000							
Byte 2	Bit 23	Bit 22	Bit 21	Bit 20	Bit 19	Bit 18	Bit 17	Bit 16
	BPCC_EN R:0	B2_B3# R:0	Reserved R:0000000					
Byte 1	Bit 15	Bit 14	Bit 13	Bit 12	Bit 11	Bit 10	Bit 9	Bit 8
	PME Status R/W:Sticky	Data Scale R:00		Data Select R:0000			PME Enable (PME_En) R/W:Sticky	
Byte 0	Bit 7	Bit 6	Bit 5	Bit 4	Bit 3	Bit 2	Bit 1	Bit 0
	Reserved R:0000000						Power State R/W:00	

Bits 1:0 — Power State

These two bits define the ACPI-defined power state of the socket interface.

Bit 1	Bit 0	Power State of Socket Interface
0	0	D0
0	1	D1
1	0	D2
1	1	D3

Bits 7:2 — Reserved

Bit 8 — PME Enable (PME_En)

This bit enables the wake-up function of the CL-PD6833. When this bit is set, wake-ups are signalled on the PME pin. When this bit is reset, no wake-ups are issued.

Bits 12:9 — Data Select

These bits read back '0's to indicate that data selection is not supported.

Bits 14:13 — Data Scale

These bits read back '0's to indicate that data readback is not supported.

Bit 15— PME Status

This bit indicates that an event has occurred that, if the **PME Enable** bit is set, would cause PME to be signalled. Writing a '1' to this bit clears it to '0', and writing '0' to this bit has no effect.

Bits 21:16 — Reserved

Bit 22 — B2_B3# (B2/B3 Support for D3_{hot})

This bit set to '0' and is not meaningful because bit 23 (BPCC_EN) is set to '0'.

Bit 23 — BPCC_EN (Bus Power / Clock Control Enable)

This bit is set to '0'. A '0' indicates that the bus power/clock control policies have been disabled.

NOTE: Bits 23:16 always read back '0's to indicate that the data register is not supported.

Bits 31:24 — Data

5.17 DMA Slave Configuration Register

<i>Register Name:</i> DMA Slave Configuration Register								<i>Register Per:</i> socket		
<i>Offset:</i> 90h										
Byte 3	Bit 31	Bit 30	Bit 29	Bit 28	Bit 27	Bit 26	Bit 25	Bit 24	DMA I/O Base Address (high)	
	R/W:00000000									
Byte 2	Bit 23	Bit 22	Bit 21	Bit 20	Bit 19	Bit 18	Bit 17	Bit 16	DMA I/O Base Address (high mid.)	
	R/W:00000000									
Byte 1	Bit 15	Bit 14	Bit 13	Bit 12	Bit 11	Bit 10	Bit 9	Bit 8	DMA I/O Base Address (low mid.)	
	R/W:00000000									
Byte 0	Bit 7	Bit 6	Bit 5	Bit 4	Bit 3	Bit 2	Bit 1	Bit 0	DMA I/O Base Address (low)	
	R/W:0000				Non-Legacy Extended Addressing R/W:0		Transfer Size R/W:00		Channel Enable R/W:0	

This is the DMA I/O base address for the **DMA** registers.

Bit 0 — Channel Enable

This bit, along with the DREQ Enable bits in **Extension Control 1**, enables the DMA channel. When this bit is '0', DMA operations are not allowed. If both of the DREQ Enable bits in **Extension Control 1** are '0's, DMA operations are not allowed.

Bits 2:1 — Transfer Size

These bits define the size of the DMA transfer at the PC Card 16 (R2) socket.

Bit 2	Bit 1	Size of DMA Transfer at the PC Card 16 (R2) Socket
0	0	8-bit transfer at the PC Card
0	1	16-bit transfers at the PC Card
1	0	16-bit transfers at the PC Card ^a
1	1	16-bit transfers at the PC Card ^a

^a These two settings are implemented for compatibility with current R2 conventions.

Bit 3 — Non-Legacy Extended Addressing

When this bit is set to '1', it enables use of the DMA extended addressing.

Bits 31:4 — DMA I/O Base Address

These bits are used to define the I/O address where the **DMA Operation** registers can be located.

5.18 Socket Number

<i>Register Name: Socket Number</i>								<i>Register Per: socket</i>	
<i>Offset: 94h</i>									
<i>Byte 3</i>	<i>Bit 31</i>	<i>Bit 30</i>	<i>Bit 29</i>	<i>Bit 28</i>	<i>Bit 27</i>	<i>Bit 26</i>	<i>Bit 25</i>	<i>Bit 24</i>	
	<i>Reserved</i>								R:00000000
<i>Byte 2</i>	<i>Bit 23</i>	<i>Bit 22</i>	<i>Bit 21</i>	<i>Bit 20</i>	<i>Bit 19</i>	<i>Bit 18</i>	<i>Bit 17</i>	<i>Bit 16</i>	
	<i>Reserved</i>								R:00000000
<i>Byte 1</i>	<i>Bit 15</i>	<i>Bit 14</i>	<i>Bit 13</i>	<i>Bit 12</i>	<i>Bit 11</i>	<i>Bit 10</i>	<i>Bit 9</i>	<i>Bit 8</i>	
	<i>Reserved</i>								R:00000000
<i>Byte 0</i>	<i>Bit 7</i>	<i>Bit 6</i>	<i>Bit 5</i>	<i>Bit 4</i>	<i>Bit 3</i>	<i>Bit 2</i>	<i>Bit 1</i>	<i>Bit 0</i>	
	<i>Reserved</i>						Socket Number		
R:00000						R/W:000 / 001			

This is the socket number used for backward-compatible addressing in the I/O space.

Bits 2:0 — Socket Number

These bits define the socket number that is used for the I/O addressing mode of operation. Sockets A and B must have the same address, and therefore bit 2 of this register must be the same for each configuration space.

Bit 2	Bit 1	Bit 0	Socket Number	Index Range	Example PCI I/O Address (If PCI I/O Base Address Is Programmed to 03E0)
0	0	0	0	00h—3Fh	Index Register at 03E0, Data at 03E1
0	0	1	1	40h—7Fh	Index Register at 03E0, Data at 03E1
0	1	0	2	80h—BFh	Index Register at 03E0, Data at 03E1
0	1	1	3	C0h—FFh	Index Register at 03E0, Data at 03E1
1	0	0	4	00h—3Fh	Index Register at 03E2, Data at 03E3
1	0	1	5	40h—7Fh	Index Register at 03E2, Data at 03E3
1	1	0	6	80h—BFh	Index Register at 03E2, Data at 03E3
1	1	1	7	C0h—FFh	Index Register at 03E2, Data at 03E3

For software compatibility with earlier CL-PD67XX PC Card host adapters, many of the CL-PD6833 internal registers are accessible at the I/O address pair 03E0h and 03E1h by setting a register index at one address, and then accessing the 8-bit register data at the next address.

With this organization, bits 7:6 of the index value are used to select access to Socket A or Socket B registers. In an ISA environment, bits 7:6 of the index value can also be used to select one of four sockets when two PC Card host adapters are paired in a system.

Some older PC Card host adapters also allow setting of its older address pair to 03E2h and 03E3h instead of the default 03E0h and 03E1h. This could allow up to eight sockets to be supported in a system: four at the I/O address pair 03E0/03E1h and four at the I/O address pair 03E2/03E3h.

Bits 2:0 of this register can be used to map I/O space-accessible internal registers for a socket into an I/O address pair and index range so that it appears as a particular socket number out of the eight possible socket number locations found in older ISA-based PC Card host adapters.

Refer to [Chapter 7](#) for information about the organization of the **Index** register.

Bits 31:3 — Reserved

5.19 Configuration Miscellaneous 1

Register Name: Configuration Miscellaneous 1		Register Per: socket						
Offset: 98h								
Byte 3	Bit 31	Bit 30	Bit 29	Bit 28	Bit 27	Bit 26	Bit 25	Bit 24
	Reserved R:00000000							
Byte 2	Bit 23	Bit 22	Bit 21	Bit 20	Bit 19	Bit 18	Bit 17	Bit 16
	Reserved R:00000000							
Byte 1	Bit 15	Bit 14	Bit 13	Bit 12	Bit 11	Bit 10	Bit 9	Bit 8
	Reserved R:000000					D3 Disable Auto Reset — PME_CXT R/W:0	Disable Master Prefetch R/W:0	Pin Mapping Lock R/W:0
Byte 0	Bit 7	Bit 6	Bit 5	Bit 4	Bit 3	Bit 2	Bit 1	Bit 0
	Reserved R:00000					Enable INTA#, INTB# in PCI/Way R/W:0	Management Enable R/W:0	Subsystem Vendor ID Lock R/W:0

Bit 0 — Subsystem Vendor ID Lock

This bit defaults to '0'. When this bit is set to '1', the **Subsystem Vendor ID and Subsystem Device ID** registers (memory offset 40h) become read only. This register is per chip.

Bit 1 — Management Enable

This bit is used to control the routing of management interrupts to the ISA IRQ or PCI INT pin. This is used only when the CL-PD6833 is programmed for non-PCI style interrupts.

0	Management interrupts are routed to the INT pin indicated by the Interrupt Pin register (memory offset 3Dh): INTA# for Socket A and INTB# for Socket B.
1	Management interrupts are routed to the ISA IRQ line (IRQ3, 4, 5, 7, 11, 12, 14, or 15) as indicated by the Management Interrupt Configuration register (memory offset 805h).

Bit 2 — Enable INTA#, INTB# in PCI/Way

This register is per chip.

0	PCI/Way data stream is compatible with the CL-PD6832.
1	INTA# and INTB# are included in the PCI/Way data stream.

Bits 7:3 — Reserved

Bit 8 — Pin Mapping Lock

This bit determines the PCI memory space 914h–915h pin mapping register accessibility. (Bit position is R/W for each socket: chip-level function, programmable in function 0 only.)

0	Pin mapping can be programmed in register 914–915h.
1	Write access to register 914–915h is disabled.

Bit 9 — Disable Master Prefetch

This bit determines the CardBus Master Prefetch behavior. (Bit position is R/W for each socket: chip-level function, programmable in function 0 only.)

0	CardBus master prefetching from PCI memory is allowed.
1	CardBus master prefetching from PCI is disabled.

Bit 10 — D3 Disable Auto Reset — PME_CXT

This bit determines the CL-PD6833 action when the socket's PCI function is in D3 power state. This bit is part of the PME_CXT, a set of register bits that do not get reset or initialized if PME Enable is true when the CL-PD6833 changes power states from D3 to D0 through a software PCI Bus Segment reset.

0	Reset signal to cards is activated in D3 if card is powered.
1	Automatic Card Reset in D3 is disabled.

Bits 31:11 — Reserved

6. CARDBUS REGISTERS

The CardBus registers occupy offsets 000h–7FFh from the **Memory Base Address** register. These registers are reset by RST#.

Table 6-1. CardBus Registers Quick Reference

Register Name	Memory Offset	Page Number
Status Event — PME_CXT	000h	75
Status Mask — PME_CXT	004h	77
Present State	008h	78
Event Force	00Ch	80
Control — PME_CXT	010h	82

6.1 Status Event — PME_CXT

Register Name: Status Event — PME_CXT								Register Per: socket
Memory Offset: 000h								
Bit 31	Bit 30	Bit 29	Bit 28	Bit 27	Bit 26	Bit 25	Bit 24	
<i>Reserved</i>								
R:00000000								
Bit 23	Bit 22	Bit 21	Bit 20	Bit 19	Bit 18	Bit 17	Bit 16	
<i>Reserved</i>								
R:00000000								
Bit 15	Bit 14	Bit 13	Bit 12	Bit 11	Bit 10	Bit 9	Bit 8	
<i>Reserved</i>								
R:00000000								
Bit 7	Bit 6	Bit 5	Bit 4	Bit 3	Bit 2	Bit 1	Bit 0	
<i>Reserved</i>				Power Cycle	CCD2	CCD1	CSTSCHG/ WAKEUP	
R:0000				R/C:0	R/C:0	R/C:0	R/C:0	

NOTE: PME_CXT (PME Context) is a set of register bits that do not get reset or initialized if PME Enable is true when the CL-PD6833 changes power states from D3 to D0 through a software PCI Bus Segment reset.

The **Status Event** register indicates when a change in socket status occurs. These bits do not indicate what the change is, only that a change occurred. Software must read the **Present State** register for current status. Bits 3:0 can be cleared by writing a ‘1’ to each bit. These bits can be set to ‘1’ by software through writing ‘1’ to the corresponding bit in the **Event Force** register, provided the **Status Mask** register has been set. All bits in this register are cleared by RST#. Software needs to clear this register before enabling interrupts.

Bit 0 — CSTSCHG/WAKEUP (Card Status Change and/or Wakeup)

This bit indicates that the CSTSCHG and/or WAKEUP signal has been asserted. It only indicates the assertion event. It is not a reflection of the CSTSCHG bit from the card. It is latched by the controller and must be explicitly cleared by the appropriate software. The status change interrupt, driven by the controller, must be based on this event bit rather than the **Present Value** register.

When a card is powered, this bit indicates a status change and is driven continuously by the card. When a socket is powered down, this bit is a WAKEUP bit. A card might only drive it for 1 ms to limit drain on a battery. To be used in this manner, a card must have an external supply or battery. Deassertion of CSTSCHG is controlled by software or a reset clearing the signal on the bus. Indicating that change would not be useful.

This bit is not set if an event is detected during the time period when the CL-PD6833 has started the power-up cycle of the socket, but has not yet signalled a Power Up Complete interrupt. This prevents spurious signals from a card during power-up, generating invalid events. This bit is re-enabled when the Power Complete interrupt is generated. During the power down sequence, the card is responsible for preventing glitches.

Bit 1 — CCD1

This bit indicates a change has occurred in the corresponding Card Detect bit.

Bit 2 — CCD2

This bit indicates a change has occurred in the corresponding Card Detect bit.

Bit 3 — Power Cycle

This bit defaults to '0'. It is set to '1' by the CL-PD6833 to indicate that the device has completed powering up or powering down. The **Present State** register (memory offset 008h) should be read to determine that the voltage requested is actually applied. The CL-PD6833 does not allow an unsupported voltage to be applied to a PC Card 32 (CardBus) card. This bit is meaningless when a 16-bit card is in the socket. It is not possible to power up a PC Card 32 (CardBus) card to a voltage not indicated by the VS/CD lines.

Bits 31:4 — Reserved

6.2 Status Mask — PME_CXT

Register Name: Status Mask — PME_CXT		Register Per: socket						
Memory Offset: 004h								
Byte 3	Bit 31	Bit 30	Bit 29	Bit 28	Bit 27	Bit 26	Bit 25	Bit 24
	Reserved R:00000000							
Byte 2	Bit 23	Bit 22	Bit 21	Bit 20	Bit 19	Bit 18	Bit 17	Bit 16
	Reserved R:00000000							
Byte 1	Bit 15	Bit 14	Bit 13	Bit 12	Bit 11	Bit 10	Bit 9	Bit 8
	Reserved R:00000000							
Byte 0	Bit 7	Bit 6	Bit 5	Bit 4	Bit 3	Bit 2	Bit 1	Bit 0
	Reserved R:0000				Power Cycle Complete R/W:0	CCD2 Changed R/W:0	CCD1 Changed R/W:0	CSTSCHG/ WAKEUP R/W:0

NOTE: PME_CXT (PME Context) is a set of register bits that do not get reset or initialized if PME Enable is true when the CL-PD6833 changes power states from D3 to D0 by a software PCI Bus Segment reset.

This register gives software the ability to control the events that can cause interrupts. If the Card Detect Changed bit is enabled at the time a card is removed, an interrupt is generated. This register is cleared automatically when card is removed. If the CL-PD6833 is required to generate an interrupt when a new card is inserted, software must again set the Card Detect Changed mask bit.

Bit 0 — CSTSCHG/WAKEUP (Card Status Change / Wakeup)

When set, this bit enables an interrupt based on the CSTSCHG signal being asserted by a CardBus card. CSTSCHG interrupts generated by 16-bit cards are controlled by registers in that interface's register space. This bit is disabled when it is '0'.

Bit 1 — CCD1 Changed

When set, this bit enables an interrupt when the CL-PD6833 detects change.

Bit 2 — CCD2 Changed

When set, this bit enables an interrupt when the CL-PD6833 detects change.

Bit 3— Power Cycle Complete

When set, this bit causes the CL-PD6833 to generate an interrupt 256 cycles of the PCI clock after powering up a socket.

Bits 31:4 — Reserved

6.3 Present State

Register Name: Present State		Register Per: socket					
Memory Offset: 008h							
Bit 31	Bit 30	Bit 29	Bit 28	Bit 27	Bit 26	Bit 25	Bit 24
Y-V Socket	X-V Socket	3.3-V Socket	5-V Socket	Reserved			
RU ^a R:0	RU ^a R:0	RU ^a R:1	RU ^a R:1	R:0000			
Bit 23	Bit 22	Bit 21	Bit 20	Bit 19	Bit 18	Bit 17	Bit 16
Reserved							
R:00000000							
Bit 15	Bit 14	Bit 13	Bit 12	Bit 11	Bit 10	Bit 9	Bit 8
Reserved		Y-V Card	X-V Card	3.3-V Card	5-V Card	Bad V _{CC} Request	Data Lost
R:00		RU ^a R:0	RU ^a R:0	RU ^a R:0	RU ^a R:0	RU ^a R:0	R RC:0
Bit 7	Bit 6	Bit 5	Bit 4	Bit 3	Bit 2	Bit 1	Bit 0
Not a Card	Interrupt	CardBus PC Card	16-Bit PC Card	Power Cycle Complete	CCD2	CCD1	CSTSCHG/WAKEUP
RU ^a R:0	RU ^a R:0	RU ^a R:0	RU ^a R:0	RU ^a R:0	RU ^a R:1	RU ^a R:1	RU ^a R:0

^a RU indicates a read update.

The **Socket Present State** register reflects the present value of the socket status. Some of the bits in this register are merely reflections of interface signals, while others are flags set to indicate a status change.

Bit 0 — CSTSCHG/WAKEUP

This bit reflects the current status of the CSTSCHG/WAKEUP pin on the CardBus interface.

Bit 1 — CCD1

This bit provides for detection of a PC Card insertion/removal/presence. It is also used by the CL-PD6833, in conjunction with CVS1, to determine the card type (PC Card 16 vs. PC Card 32). It is a reflection of the CCD1 pin.

Bit 2 — CCD2

This bit provides for detection of a PC Card insertion/removal/presence. It is also used by the CL-PD6833, in conjunction with CVS2, to determine the card type (PC Card 16 vs. PC Card 32). It is a reflection of the CCD2 pin.

Bit 3 — Power Cycle Complete

When this bit is set, it indicates that the interface is powered up. When this bit is cleared, the socket is powered down. This bit is set to '0' by PCIRST#.

Bit 4 — 16-Bit PC Card

When this bit is set, it indicates that the Card Detect state machine determined a PC Card 16 (R2) card was inserted. This bit is cleared when another card, one that is not 16-bit, is inserted. This bit is set to '0' by PCIRST#.

Bit 5 — CardBus PC Card

When this bit is set, it indicates that the Card Detect state machine determined a PC Card 32 (CardBus) card was inserted. This bit is cleared when another card, one that is not CardBus, is inserted. This bit is set to '0' by RST#.

NOTE: This bit and the 16-Bit PC Card bit do not indicate that a card is installed. They only indicate what kind of card was last installed. The Card Detect bits indicate if a card is currently in the socket.

Bit 6 — Interrupt

When this bit is set to '1', it indicates that the inserted card is driving its interrupt pin active. This bit is not registered and its assertion/deassertion follows the interrupt pin from the card.

Bit 7 — Not a Card

This bit indicates that an unsupported card is installed in the socket. The CL-PD6833 does not allow power to be applied to the socket if this bit is set. This bit is set to '0' by RST#.

Bit 8 — Data Lost

This bit indicates that a card was removed while the interface was active. Data may be lost. Any data in the CL-PD6833 data buffers is lost when this event occurs. This bit is set to '0' by RST#.

This bit allows software to fail in a graceful manner, if it chooses to, when this occurs.

Bit 9 — Bad V_{CC} Request

This bit indicates that software attempted to apply an unsupported or incorrect voltage level to a PC Card 32 (CardBus) card. This bit is set to '0' by RST#.

Bit 10 — 5-V Card

When this bit is set, the card installed requires and/or supports 5.0-V operation. This bit is set by the state machine used to detect card voltage requirements. This bit is set to '0' by RST#.

Bit 11 — 3.3-V Card

When this bit is set, the card installed requires and/or supports 3.3-V operation. This bit is set by the state machine used to detect card voltage requirements. This bit is set to '0' by RST#.

Bit 12 — X-V Card

When this bit is set, the card installed requires and/or supports X-V operation. This bit is set by the state machine used to detect card voltage requirements. This bit is set to '0' by RST#.

Bit 13 — Y-V Card

When this bit is set, the card installed requires and/or supports Y-V operation. This bit is set by the state machine used to detect card voltage requirements. This bit is set to '0' by RST#.

Bits 27:14 — Reserved

Bits 31:28 — Socket Voltage Availability

These bits indicate the V_{CC} voltages available for the sockets in this system.

31	30	29	28
Y V	X V	3.3 V	5.0 V

6.4 Event Force

Register Name: Event Force		Register Per: socket						
Memory Offset: 00Ch								
	Bit 31	Bit 30	Bit 29	Bit 28	Bit 27	Bit 26	Bit 25	Bit 24
Byte 3	Reserved R:00000000							
	Bit 23	Bit 22	Bit 21	Bit 20	Bit 19	Bit 18	Bit 17	Bit 16
Byte 2	Reserved R:00000000							
	Bit 15	Bit 14	Bit 13	Bit 12	Bit 11	Bit 10	Bit 9	Bit 8
Byte 1	Reserved W:0	CV Test W:0	Y-V W:0	X-V W:0	3.3-V Card W:0	5-V Card W:0	Bad V _{CC} Request W:0	Data Lost W:0
	Bit 7	Bit 6	Bit 5	Bit 4	Bit 3	Bit 2	Bit 1	Bit 0
Byte 0	Not a Card W:0	Reserved W:0	CardBus PC Card W:0	16-Bit PC Card W:0	Power Cycle W:0	CCD2 Changed W:0	CCD1 Changed W:0	CSTSCHG/WAKEUP W:0

The **Event Force** register is a phantom register. These bits are merely control bits. They are not registered and need no clearing. They provide software the ability to force various status and event bits in the CL-PD6833. This gives software the ability to test and restore status. Writing '1' to a bit in this register sets the corresponding bit in the **Status Event** register and/or the **Present State** register. Bits 3:0 generate Management Interrupt if the correct Mask bit is set.

Bit 0 — CSTSCHG/WAKEUP

This bit sets the Card Status Change bit in the **Status Event** register. The **Present State** register remains unchanged.

Bit 1 — CCD1 Changed

This bit sets the CCD1 bit in the **Status Event** register. The **Present State** register remains unchanged.

Bit 2 — CCD2 Changed

This bit sets the CCD2 bit in the **Status Event** register. The **Present State** register remains unchanged.

Bit 3 — Power Cycle

This bit sets the Power Cycle bit in the **Status Event** register. The **Present State** register remains unchanged.

Bit 4 — 16-Bit PC Card

This bit sets the 16-bit PC Card bit in the **Present State** register. If a card is installed in the socket, writes to this bit are ignored.

Bit 5 — CardBus PC Card

This bit sets the CardBus PC Card bit in the **Present State** register. If a card is installed in the socket, writes to this bit are ignored.

Bit 7 — Not a Card

This bit sets the Not a Card bit in the **Present State** register. If a card is installed in the socket, writes to this bit are ignored.

Bit 8 — Data Lost

This bit causes the Data Lost bit to be set in the **Present State** register.

Bit 9 — Bad V_{CC} Request

This bit causes the Bad V_{CC} Request bit in the **Present State** register to be set.

Bit 10 — 5-V Card

This bit causes the 5-V Card bit in the **Present State** register to be set. Writes to this bit disable the CL-PD6833's ability to power up the socket. To change the voltage of a card, after forcing this bit, the CL-PD6833 must either receive a RST# or retest the card's supported voltages. The latter can be accomplished by forcing the CV Test bit (bit 14 in this register). This is necessary to prevent software from applying an incorrect voltage to the PC Card.

Bit 11 — 3.3-V Card

This bit causes the 3.3-V Card bit in the **Present State** register to be set. Writes to this bit disables the CL-PD6833's ability to power up the socket. To change the voltage of a card, after forcing this bit, the CL-PD6833 must either receive a RST# or retest the card's supported voltages. The latter can be accomplished by forcing the CV Test bit (bit 14 in this register). This is necessary to prevent software from applying an incorrect voltage to the PC Card.

Bit 12 — X-V Card

This bit causes the X-V Card bit in the **Present State** register to be set. Writes to this bit disables the CL-PD6833's ability to power up the socket. To change the voltage of a card, after forcing this bit, the CL-PD6833 must either receive a RST# or retest the card's supported voltages. The latter can be accomplished by forcing the CV Test bit (bit 14 in this register). This is necessary to prevent software from applying an incorrect voltage to the PC Card.

Bit 13 — Y-V Card

This bit causes the Y-V Card bit in the **Present State** register to be set. Writes to this bit disables the CL-PD6833's ability to power up the socket. To change the voltage of a card, after forcing this bit, the CL-PD6833 must either receive a RST# or retest the card's supported voltages. The latter can be accomplished by forcing the CV Test bit (bit 14 in this register). This is necessary to prevent software from applying an incorrect voltage to the PC Card.

Bit 14 — CV Test

This bit causes the controller to test the VS and CCD lines to determine card type and voltages supported. This test is run automatically when a new card is inserted.

Bits 31:15 — Reserved

6.5 Control — PME_CXT

Register Name: Control — PME_CXT		Register Per: socket						
Memory Offset: 010h								
Byte 3	Bit 31	Bit 30	Bit 29	Bit 28	Bit 27	Bit 26	Bit 25	Bit 24
	Reserved R:00000000							
Byte 2	Bit 23	Bit 22	Bit 21	Bit 20	Bit 19	Bit 18	Bit 17	Bit 16
	Reserved R:00000000							
Byte 1	Bit 15	Bit 14	Bit 13	Bit 12	Bit 11	Bit 10	Bit 9	Bit 8
	Reserved R:00000000							
Byte 0	Bit 7	Bit 6	Bit 5	Bit 4	Bit 3	Bit 2	Bit 1	Bit 0
	Stop Clock R/W:0	V _{CC} Control R/W:000		Reserved R:0		V _{PP} Control R/W:000		

NOTE: PME_CXT (PME Context) is a set of register bits that do not get reset or initialized if PME Enable is true when the CL-PD6833 changes power states from D3 to D0 by a software PCI Bus Segment reset.

The **Socket Control** register provides control of the socket's V_{CC} and V_{PP}. All bits in this register are set to '0' by RST# and power removed from the socket. This register is write-protected by writes to bits 13:10 of the **Event Force** register, and not write-protected on completion of the decoding sequence of the CD1, CD2, VS1, and VS2 lines or completion of CV test. Use either this register or the **Power Control** register (index 02h) for power control. Do not use both registers.

Bits 2:0 — V_{PP} Control

These bits are used to switch the V_{PP} power using external V_{PP} control logic. The CL-PD6833 has no knowledge of a card's V_{PP} voltage requirement. Software must determine the needed voltage from the card's CIS. The following table shows the V_{PP} requested depending on the setting of the bits.

Bit 2	Bit 1	Bit 0	V _{PP} Requested
0	0	0	0 V
0	0	1	12.0 V
0	1	0	5.0 V
0	1	1	3.3 V
100—111			Reserved

Bits 6:4 — V_{CC} Control

These bits are used to control the power to the PC Card using external control logic. The CL-PD6833 determines the voltages that can be applied by decoding the CD and VS signals according to the *CardBus specification*, which are reflected in the **Present State** register. The settings in the **Present State** register that determine the voltages available in the system determine the V_{CC} options. The value written to this register must agree with the value needed to apply the correct value of V_{CC}. The CL-PD6833 must not allow an incorrect V_{CC} voltage to be applied to a socket. The voltages available are shown in the **Status** register.

Bit 6	Bit 5	Bit 4	Voltage
0	0	0	0 V
0	0	1	Reserved
0	1	0	5.0 V
0	1	1	3.3 V
100—111			Reserved

Bit 7 — Stop Clock

This bit is not implemented in the CL-PD6833.

Bits 31:8 — Reserved

Notes

7. OPERATION REGISTERS

In I/O mode, the CL-PD6833 internal **Device Control, Window Mapping, Extension, and Timing** registers are accessed through a pair of Operation registers — an **Index** register and a **Data** register.

The **Index** register is accessed at the address that is programmed in the **I/O Base Address** register, and the **Data** register (see [page 90](#)) is accessed by adding 1 to the programmed address in the **I/O Base Address** register.



Figure 7-1. Operation Registers as PCI Doubleword I/O Space at I/O Base Address Register (Programmed at Configuration Space, Offset 44h)

7.1 Index

<i>Register Name: Index</i>				<i>Register Per: chip</i>			
<i>I/O Index: n/a</i>				<i>Register Compatibility Type: 365</i>			
<i>Bit 7</i>	<i>Bit 6</i>	<i>Bit 5</i>	<i>Bit 4</i>	<i>Bit 3</i>	<i>Bit 2</i>	<i>Bit 1</i>	<i>Bit 0</i>
Socket Index		Register Index					
R/W:00		R/W:000000					

Bits 5:0 — Register Index

These bits determine which of the 64 possible socket-specific registers are accessed when the **Data** register is next accessed by the processor. Note that some values of the Register Index field are reserved (see [Table 7-1 on page 86](#)).

Bits 7:6 — Socket Index

These bits determine which set of socket-specific registers are selected.

The **Index** register value determines which internal register should be accessed (read or written) in response to each CPU access of the **Data** register. Each of the two possible PC Card sockets is allocated 64 of the 256 locations in the internal register index space.

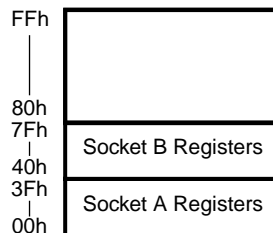


Figure 7-2. Socket and Register Index Space

When viewed as a 7-bit value, the contents of this register completely specify a single internal-register byte. For example, at reset, when the value of this register is in the range 00h–3Fh, the **Socket A** register is selected (Socket Index bit is '0'), and when the value of this register is in the range 40h–7Fh, the **Socket B** register is selected (Socket Index bit is '1').

The internal register that is accessed when the CPU reads or writes the **Data** register is determined by the current value of the **Index** register, as follows:

Table 7-1. Index Registers

Register Name	I/O Index Value Six-bit Value	Memory Offset Value	Chapter	Page
Chip Revision	00h ^a	800h ^a	Chapter 8, "DEVICE CONTROL REGISTERS"	91
Interface Status	01h	801h		92
Power Control	02h	802h		94
Interrupt and General Control	03h	803h		96
Card Status Change	04h	804h		98
Management Interrupt Configuration	05h	805h		99
Mapping Enable	06h	806h		101
I/O Window Control	07h	807h		Chapter 10, "GENERAL WINDOW MAPPING REGISTERS"
Gen Map 5 Start Address Low	08h	808h	125	
Gen Map 5 Start Address High	09h	809h	126	
Gen Map 5 End Address Low	0Ah	80Ah	127	
Gen Map 5 End Address High	0Bh	80Bh	128	
Gen Map 6 Start Address Low	0Ch	80Ch	125	
Gen Map 6 Start Address High	0Dh	80Dh	126	
Gen Map 6 End Address Low	0Eh	80Eh	127	
Gen Map 6 End Address High	0Fh	80Fh	128	
Gen Map 0 Start Address Low	10h	810h	125	
Gen Map 0 Start Address High	11h	811h	126	
Gen Map 0 End Address Low	12h	812h	127	
Gen Map 0 End Address High	13h	813h	128	
Gen Map 0 Offset Address Low	14h	814h	123	
Gen Map 0 Offset Address High	15h	815h	124	
Misc Control 1	16h	816h	Chapter 11, "EXTENSION REGISTERS"	
FIFO Control	17h	817h		134
Gen Map 1 Start Address Low	18h	818h	Chapter 10, "GENERAL WINDOW MAPPING REGISTERS"	125
Gen Map 1 Start Address High	19h	819h		126
Gen Map 1 End Address Low	1Ah	81Ah		127
Gen Map 1 End Address High	1Bh	81Bh		128
Gen Map 1 Offset Address Low	1Ch	81Ch		123
Gen Map 1 Offset Address High	1Dh	81Dh		124
Misc Control 2	1Eh ^a	81Eh ^a	Chapter 11, "EXTENSION REGISTERS"	136
Chip Information	1Fh ^a	81Fh ^a		137

Table 7-1. Index Registers (cont.)

Register Name	I/O Index Value Six-bit Value	Memory Offset Value	Chapter	Page
Gen Map 2 Start Address Low	20h	820h	Chapter 10, "GENERAL WINDOW MAPPING REGISTERS"	125
Gen Map 2 Start Address High	21h	821h		126
Gen Map 2 End Address Low	22h	822h		127
Gen Map 2 End Address High	23h	823h		128
Gen Map 2 Offset Address Low	24h	824h		123
Gen Map 2 Offset Address High	25h	825h		124
ATA Control	26h	826h	Chapter 11, "EXTENSION REGISTERS"	138
<i>Scratchpad</i>	27h	827h	–	–
Gen Map 3 Start Address Low	28h	828h	Chapter 10, "GENERAL WINDOW MAPPING REGISTERS"	125
Gen Map 3 Start Address High	29h	829h		126
Gen Map 3 End Address Low	2Ah	82Ah		127
Gen Map 3 End Address High	2Bh	82Bh		128
Gen Map 3 Offset Address Low	2Ch	82Ch		123
Gen Map 3 Offset Address High	2Dh	82Dh		124

Table 7-1. Index Registers (cont.)

Register Name	I/O Index Value Six-bit Value	Memory Offset Value	Chapter	Page
Extended Index:	2Eh	–	Chapter 11, "EXTENSION REGISTERS"	140
Scratchpad	Extended index 00h	900h		–
Reserved	Extended index 01h	Reserved		–
Reserved	Extended index 02h	Reserved		–
Extension Control 1	Extended index 03h	903h		143
Reserved	Extended index 04h	Reserved		–
Gen Map 0 Upper Address	Extended index 05h	840h		143
Gen Map 1 Upper Address	Extended index 06h	841h		143
Gen Map 2 Upper Address	Extended index 07h	842h		143
Gen Map 3 Upper Address	Extended index 08h	843h		143
Gen Map 4 Upper Address	Extended index 09h	844h		143
Reserved	Extended index 0Ah	90Ah		–
Reserved	Extended index 0Bh	90Bh		–
Reserved	Extended index 0Ch–17h	Reserved		–
Pin Multiplex Control 0		914h		144
Pin Multiplex Control 1		915h		146
GPIO Output Control	Extended Index 18h	918h		147
GPIO Input Control	Extended Index 19h	919h		147
GPIO Output Data	Extended Index 1Ah	91Ah		148
GPIO Input Data	Extended Index 1Bh	91Bh		148
Prefetch Window Register	Extended Index 1Ch–1Fh	91Ch–91Fh		149
Gen Map 5 Upper Address	Extended index 20h	845h		143
Gen Map 6 Upper Address	Extended index 21h	846h		143
PCI Space Control	Extended index 22h	922h		149
PC Card Space Control	Extended index 23h	923h		150
Window Type Select	Extended index 24h	924h		150
Misc. Control 3	Extended index 25h	925h		151
SMB Power Control Address	Extended index 26h	926h		153
Gen Map 0 Extra Control	Extended index 27h	927h		154
Gen Map 1 Extra Control	Extended index 28h	928h		154
Gen Map 2 Extra Control	Extended index 29h	929h		154
Gen Map 3 Extra Control	Extended index 2Ah	92Ah		154
Gen Map 4 Extra Control	Extended index 2Bh	92Bh		154
Gen Map 5 Extra Control	Extended index 2Ch	92Ch		154
Gen Map 6 Extra Control	Extended index 2Dh	92Dh		154
Extension Card Status Change	Extended index 2Eh	92Eh		156
Misc. Control 4	Extended index 2Fh	92Fh		157
Misc. Control 5	Extended index 30h	930h		158
Misc. Control 6	Extended index 31h	931h		158
Mask Revision Byte	Extended index 34h	934h		159
Product ID Byte	Extended index 35h	935h		160
Device Capability Byte A	Extended index 36h	936h		161
Device Capability Byte B	Extended index 37h	937h		162
Device Implementation Byte A	Extended index 38h	938h		163
Device Implementation Byte B	Extended index 39h	939h		164
Device Implementation Byte C	Extended index 3Ah	93Ah		165
Device Implementation Byte D	Extended index 3Bh	93Bh		166
Extended Data	2Fh	–		
Gen Map 4 Start Address Low	30h	830h	Chapter 10, "GENERAL WINDOW MAPPING REGISTERS"	125
Gen Map 4 Start Address High	31h	831h		126
Gen Map 4 End Address Low	32h	832h		127
Gen Map 4 End Address High	33h	833h		128
Gen Map 4 Offset Address Low	34h	834h		123
Gen Map 4 Offset Address High	35h	835h		124

Table 7-1. Index Registers (cont.)

Register Name	I/O Index Value Six-bit Value	Memory Offset Value	Chapter	Page
Gen Map 5 Offset Address Low	36h	836h	Chapter 10, "GENERAL WINDOW MAPPING REGISTERS"	123
Gen Map 5 Offset Address High	37h	837h		124
Gen Map 6 Offset Address Low	38h	838h		123
Gen Map 6 Offset Address High	39h	839h		124
Setup Timing 0	3Ah	83Ah	Chapter 12, "TIMING REGISTERS"	167
Command Timing 0	3Bh	83Bh		168
Recovery Timing 0	3Ch	83Ch		169
Setup Timing 1	3Dh	83Dh		167
Command Timing 1	3Eh	83Eh		168
Recovery Timing 1	3Fh	83Fh		169
<i>Reserved</i>		905h–909h	–	–
<i>Reserved</i>		916h–917h	–	–
<i>Reserved</i>		920h–921h	–	–
<i>Scratchpad</i>		90Ch–913h	–	–
<i>Reserved</i>		847h–8FFh	–	–
<i>Reserved</i>		93Ch–FFFh	–	–

^a This register affects both sockets (it is not specific to either socket).

7.2 Data

<i>Register Name: Data</i>				<i>Register Per: chip</i>			
<i>I/O Index: n/a</i>				<i>Register Compatibility Type: 365</i>			
<i>Bit 7</i>	<i>Bit 6</i>	<i>Bit 5</i>	<i>Bit 4</i>	<i>Bit 3</i>	<i>Bit 2</i>	<i>Bit 1</i>	<i>Bit 0</i>
Data							

The **Data** register is accessed at **I/O Base Address + 1**. This register indicates the contents of the register at the Socket/Register Index selected by the **Index** register.

8. DEVICE CONTROL REGISTERS

Table 8-1. Device Control Registers Quick Reference

Register Name	I/O Index	Memory Offset	Page Number
Chip Revision	00h	800h	91
Interface Status	01h	801h	92
Power Control — PME_CXT	02h	802h	94
Interrupt and General Control — PME_CXT	03h	803h	96
Card Status Change — PME_CXT	04h	804h	98
Management Interrupt Configuration — PME_CXT	05h	805h	99
Mapping Enable	06h	–	101

8.1 Chip Revision

Register Name: Chip Revision				Register Per: chip			
I/O Index: 00h				Register Compatibility Type: 365			
Memory Offset: 800h							
Bit 7	Bit 6	Bit 5	Bit 4	Bit 3	Bit 2	Bit 1	Bit 0
Interface ID		Reserved	Reserved	Revision			
R:10		R:0	R:0	R:0010 ^a			

^a Value for the current stepping only.

Bits 3:0 — Revision

This field indicates the compatibility of the CL-PD6833 with the Intel 82365SL A-step.

Bits 5:4 — Reserved

These bits always read '0's.

Bits 7:6 — Interface ID

Bit 7	Bit 6	Interface Supported
0	0	I/O only
0	1	Memory only
1	0	Memory and I/O
1	1	Reserved

These bits identify the type of interface this controller supports. The CL-PD6833 supports both memory and I/O interface PC Cards.

8.2 Interface Status

Register Name: Interface Status				Register Per: socket			
I/O Index: 01h				Register Compatibility Type: 365			
Memory Offset: 801h							
Bit 7	Bit 6	Bit 5 RDY	Bit 4 WP	Bit 3 CD2#	Bit 2 CD1#	Bit 1 BVD2	Bit 0 BVD1
Reserved	Card Power On	Ready/Busy* / Intr. Request status	Write Protect	Card Detect		Battery Voltage Detect	
R:1 ^a	R:0	R ^b	R ^c	R ^d		R ^e	

^a Bit 7 always reads '1' on the CL-PD6833.

^b Bit 5 indicates the value of the RDY/IREQ# pin (see [page 18](#)) in PC Card 16 mode. In I/O card mode, this bit is used to identify the source of interrupt request either from socket A or B. In I/O card mode, this bit always indicates the inverted state of the RDY/BSY INTR# pin.

^c Bit 4 indicates the value of the WP/IOIS16# pin (see [page 18](#)).

^d Bits 3:2 indicate the inversion of the values of the CD1# and CD2# pins (see [page 18](#)).

^e Bits 1:0 indicate the values of the BVD1/STSCHG#/RI# and BVD2/SPKR#/LED# pins (see [page 19](#)).

Bits 1:0 — Battery Voltage Detect

BVD2 Level	BVD1 Level	Bit 1	Bit 0	PCMCIA Interpretation
Low	Low	0	0	Card data lost
Low	High	0	1	Battery low warning
High	Low	1	0	Card data lost
High	High	1	1	Battery/data okay

In Memory Card Interface mode, these bits are used by PC Card support software and firmware to indicate the remaining capacity of the battery in the PC Cards. In I/O Card Interface mode, bit 0 indicates the state of the BVD1/STSCHG#/RI# pin (see [page 20](#)). Bit 1 status is not valid in I/O Card Interface mode.

Bits 3:2 — Card Detect

CD2# Level	CD1# Level	Bit 3	Bit 2	Card Detect Status
High	High	0	0	Either no card, or card is not fully inserted
High	Low	0	1	Card is not fully inserted
Low	High	1	0	Card is not fully inserted
Low	Low	1	1	Card is fully inserted

These bits indicate the state of the CD1# and CD2# pins (see [page 18](#)).

Bit 4 — Write Protect

0	Card is not write-protected.
1	Card is write-protected.

In Memory Card Interface mode, this bit indicates the state of the WP/IOIS16# pin (see [page 18](#)) on the card. This bit is not valid in I/O Card Interface mode.

Bit 5 — Ready / Busy* / Interrupt Request Status

0	Card is not ready.
1	Card is ready.

In Memory Card Interface mode, this bit indicates the state of the RDY/IREQ# pin (see [page 18](#)) on the card. This bit reads the state of the Interrupt Request in the I/O mode of operation. This bit can be used to examine the source of the interrupt if the card holds the Interrupt Request line active until the interrupt is serviced. This bit represents the inverted realtime value of the Interrupt Request pin.

Bit 6 — Card Power On

0	Power to the card is not on.
1	Power to the card is on.

This status bit indicates whether power to the card is on. Refer to [Table 8-2](#) for more details.

Bit 7 — Reserved

This bit always reads '1'.

8.3 Power Control — PME_CXT

Register Name: Power Control — PME_CXT				Register Per: socket			
I/O Index: 02h				Register Compatibility Type: 365			
Memory Offset: 802h							
Bit 7	Bit 6	Bit 5	Bit 4	Bit 3	Bit 2	Bit 1	Bit 0
Card Enable	Compatibility	Reserved	V _{CC} Power	Compatibility		V _{PP1} Power	
R/W:0	R/W:0	R/W:0	R/W:0	R/W:00		R/W:00	

NOTE: PME_CXT (PME Context) is a set of register bits that do not get reset or initialized if PME Enable is true when the CL-PD6833 changes power states from D3 to D0 through a software PCI Bus Segment reset.

This register is write-protected by writes to the **Event Force** register. The register is not write protected when a CV test completes. CV test can be started by a card insertion or by a write to bit 14 of the **Event Force** register. Use either the **Control** register (see [page 82](#)) or this **Power Control** register to set card power. Do not use both registers.

Table 8-2. Enabling of Socket Power Commands

RST# Level	Both CD1# and CD2# Are Active (Low)	Power Control Register	Interface Status Register (see page 92)	V _{CC} Command to Power Device	V _{PP} Command to Power Device
		V _{CC} Power (Bit 4)	Card Power On (Bit 6)		
Low	X	X	0	Inactive (high)	Inactive (low)
High	X	0	0	Inactive (high)	Inactive (low)
High	No	X	X	Inactive (high)	Inactive (low)
High	Yes	1	1	Activated by bit 1 of the Misc Control 1 register	Activated by bits 1 and 0 of the Power Control register

Table 8-3. Enabling of PC Card Output Signals to Socket

RST# Level	Both CD1# and CD2# Are Active (Low)	Power Control Register		State of the CL-PD6833 V _{CC} Command to Power Device
		V _{CC} Power (Bit 4)	Card Enable (Bit 7 ^a)	
Low	X	X	X	High-impedance
High	No	X	X	High-impedance
High	Yes	0	0	High-impedance
High	Yes	0	1	Enabled
High	Yes	1	0	High-impedance
High	Yes	1	1	Enabled

^a This only applies to PC Card 16 (R2) cards.

Bits 1:0 — V_{PP1} Power

Bit 1	Bit 0	VPP_PGM	VPP_VCC	PC Card Intended Socket Function
0	0	Inactive (low)	Inactive (low)	0 V to PC Card socket V _{PP1} pin
0	1	Inactive (low)	Active (high) ^a	Selected card V _{CC} to PC Card socket V _{PP1} pin
1	0	Active (high) ^a	Inactive (low)	+12 V to PC Card socket V _{PP1} pin
1	1	Inactive (low)	Inactive (low)	0 V to PC Card socket V _{PP1} pin

^a This state exists under conditions where V_{PP1} power is activated. See [Table 8-2](#).

These bits control the power to the V_{PP1} pin of the PC Card.

Bits 3:2 — Compatibility Bits

Bit 4 — V_{CC} Power

0	Power is not applied to the card.
1	Power is applied to the card, if CD2# and CD1# are active low, then the selected V _{CC} voltage is applied.

Setting this bit to '1' applies power to the card. The V_{CC} 3.3-V bit (see [page 132](#)) determines whether 3.3 V or 5 V power is applied. Note that this bit is reset to '0' when a card is removed from the socket. This bit is locked by the V_{CC} Power Lock bit (bit 0 of the **Extension Control 1** register, memory offset 903h).

Bit 5 — Reserved

Bit 6 — Compatibility Bit

Bit 7 — Card Enable

0	Outputs to the card socket are not enabled and are floating.
1	Outputs to the card socket are enabled if CD1# and CD2# are active low and bit 4 is '1'.

This bit only applies to R2 cards. When this bit is '1', the outputs to the PC Card are enabled if a card is present and card power is being supplied. The pins affected include CE2#, CE1#, IORD#, IOWR#, OE#, REG#, RESET, A[25:0], D[15:0], and WE#.

8.4 Interrupt and General Control — PME_CXT

<i>Register Name: Interrupt and General Control — PME_CXT</i> <i>I/O Index: 03h</i> <i>Memory Offset: 803h</i>				<i>Register Per: socket</i> <i>Register Compatibility Type: 365</i>			
Bit 7	Bit 6	Bit 5	Bit 4	Bit 3	Bit 2	Bit 1	Bit 0
Ring Indicate Enable	Card Reset*	Card is I/O	Compatibility	PC Card IRQ Selection			
R/W:0	R/W:0	R/W:0	R/W:0	R/W:0000			

NOTE: PME_CXT (PME Context) is a set of register bits that do not get reset or initialized if PME Enable is true when the CL-PD6833 changes power states from D3 to D0 through a software PCI Bus Segment reset.

Bits 3:0 — PC Card IRQ Selection

Bit 3	Bit 2	Bit 1	Bit 0	IRQ Selection
0	0	0	0	IRQ disabled
0	0	0	1	IRQ1 for PCI/Way operation, Reserved for other modes
0	0	1	0	SMI for PCI/Way operation, Reserved for other modes
0	0	1	1	IRQ3
0	1	0	0	IRQ4
0	1	0	1	IRQ5
0	1	1	0	IRQ6 for PCI/Way operation, Reserved for other modes
0	1	1	1	IRQ7
1	0	0	0	IRQ8 for PCI/Way operation, Reserved for other modes
1	0	0	1	IRQ9
1	0	1	0	IRQ10
1	0	1	1	IRQ11
1	1	0	0	IRQ12
1	1	0	1	IRQ13 for PCI/Way operation, Reserved for other modes
1	1	1	0	IRQ14
1	1	1	1	IRQ15

NOTE: This is for I/O Card Interface mode (bit 5 of this register is '1').

These bits determine which IRQ occurs when the card causes an interrupt through the RDY/IREQ# pin on the PCMCIA socket when serial interrupt signalling is used. In PCI Interrupt Signalling mode, these bits have no effect.

Bit 4 — Compatibility Bit

Bit 5 — Card is I/O

0	Sets Memory Card Interface mode. The card socket is configured to support memory-only-type cards. All dual-function socket interface pins are defined to perform memory-only-type interface functions.
1	Sets I/O Card Interface mode. The card socket is configured to support combined I/O-and-memory-type cards. All dual-function socket interface pins are defined to perform all I/O and basic memory type interface functions.

This bit determines how dual-function socket interface pins are used. For more information on specific pins, refer to [Table 2-2 on page 15](#).

Bit 6 — Card Reset*

0	The RESET signal to the card socket is set active (high for normal, low for ATA mode).
1	The RESET signal to the card socket is set inactive (low for normal, high for ATA mode).

This bit determines whether the RESET signal (see [page 19](#)) to the card is active or inactive. When the Card Enable bit (see [page 95](#)) is '0', the RESET signal to the card is high-impedance. See [Chapter 14, "ATA MODE OPERATION"](#) for further description of ATA mode functions.

Bit 7 — Ring Indicate Enable

0	BVD1/STSCHG#/RI# pin is status change function.
1	BVD1/STSCHG#/RI# pin is ring indicate input pin from card.

In R2 I/O Card Interface mode, this bit allows the BVD1/STSCHG#/RI# pin to be programmed as an active-low RING indicate input. When this bit is set to '1', the level on this input passes through to the PME# output.

8.5 Card Status Change — PME_CXT

Register Name: Card Status Change — PME_CXT				Register Per: socket			
I/O Index: 04h				Register Compatibility Type: 365			
Memory Offset: 804h							
Bit 7	Bit 6	Bit 5	Bit 4	Bit 3	Bit 2	Bit 1	Bit 0
Reserved				Card Detect Change	Ready Change	Battery Warning Change	Battery Dead Or Status Change
R:0	R:0	R:0	R:0	R:0	R:0	R:0	R:0

NOTE: PME_CXT (PME Context) is a set of register bits that do not get reset or initialized if PME Enable is true when the CL-PD6833 changes power states from D3 to D0 through a software PCI Bus Segment reset.

This register indicates the source of a management interrupt generated by the CL-PD6833.

Bit 0 — Battery Dead Or Status Change

0	A transition (from high to low in Memory Card Interface mode or either high to low or low to high in I/O Card Interface mode) on the BVD1/STSCHG#/RI# pin has not occurred since this register was last read.
1	A transition on the BVD1/STSCHG#/RI# pin has occurred.

In Memory Card Interface mode, this bit is set to '1' when the BVD1/STSCHG#/RI# pin (see [page 20](#)) changes from high to low, indicating a battery dead condition. In I/O Card Interface mode, this bit is set to '1' when the BVD1/STSCHG#/RI# pin changes from either high to low or low to high. In I/O Card Interface mode, the function of this bit is not affected by bit 7 of the **Interrupt and General Control** register. This bit is reset to '0' whenever this register is read.

Bit 1 — Battery Warning Change

0	A transition (from high to low) on the BVD2/SPKR#/LED# pin has not occurred since this register was last read.
1	A transition on the BVD2/SPKR#/LED# pin has occurred.

In Memory Card Interface mode, this bit is set to '1' when the BVD2/SPKR#/LED# pin changes from high to low, indicating a battery warning. This bit is not valid in I/O Card Interface mode. This bit is reset to '0' whenever this register is read.

Bit 2 — Ready Change

0	A transition on the RDY/IREQ# pin has not occurred since this register was last read.
1	A transition on the RDY/IREQ# pin has occurred.

This bit is '1' when a change has occurred on the RDY/IREQ# pin (see [page 18](#)). This bit is reset to '0' whenever this register is read. This bit is not valid in I/O Card Interface mode.

Bit 3 — Card Detect Change

0	A transition on neither the CD1# nor the CD2# pin has occurred since this register was last read.
1	A transition on either the CD1# or the CD2# pin or both has occurred.

This bit is set to '1' when a change has occurred on the CD1# or CD2# pin (see [page 18](#)). This bit is reset to '0' whenever this register is read.

Bits 7:4 — Reserved

These bits read '0's.

8.6 Management Interrupt Configuration — PME_CXT

Register Name: Management Interrupt Configuration — PME_CXT				Register Per: socket			
I/O Index: 05h				Register Compatibility Type: 365			
Memory Offset: 805h							
Bit 7	Bit 6	Bit 5	Bit 4	Bit 3	Bit 2	Bit 1	Bit 0
Management IRQ				Card Detect Enable	Ready Enable	Battery Warning Enable	Battery Dead Or Status Change Enable
R/W:0000				R/W:0	R/W:0	R/W:0	R/W:0

NOTE: PME_CXT (PME Context) is a set of register bits that do not get reset or initialized if PME Enable is true when the CL-PD6833 changes power states from D3 to D0 through a software PCI Bus Segment reset.

This register controls which status changes cause management interrupts. They also control the pin location where the management interrupts appear.

Bit 0 — Battery Dead Or Status Change Enable

0	Battery Dead Or Status Change management interrupt is disabled.
1	If the Battery Dead Or Status Change bit is '1', a management interrupt occurs.

When this bit is '1', a management interrupt occurs when the **Card Status Change** register's Battery Dead Or Status Change bit (see [page 98](#)) is '1'. This allows management interrupts to be generated on changes in level of the BVD1/STSCHG#/RI# pin.

Bit 1 — Battery Warning Enable

0	Battery Warning Change management interrupt is disabled.
1	If the Battery Warning Change bit is '1', a management interrupt occurs.

When this bit is '1', a management interrupt occurs if the **Card Status Change** register's Battery Warning Change bit (see [page 98](#)) is '1'. This allows management interrupts to be generated on changes in level of the BVD2/SPKR#/LED# pin. This bit is not valid in I/O Card Interface mode.

Bit 2 — Ready Enable

0	Ready Change management interrupt is disabled.
1	If the Ready Change bit is '1', a management interrupt occurs.

When this bit is '1', a management interrupt occurs when the **Card Status Change** register's Ready Change bit (see [page 98](#)) is '1'. This allows management interrupts to be generated on changes in level of the RDY/IREQ# pin. This bit is not valid in I/O Card Interface mode. This bit applies to Memory mode only.

Bit 3 — Card Detect Enable

0	Card Detect Change management interrupt is disabled.
1	If the Card Detect Change bit is '1', a management interrupt occurs.

When this bit is '1', a management interrupt occurs when the **Card Status Change** register's Card Detect Change bit (see [page 98](#)) is '1'. This allows management interrupts to be generated on changes in level of the CD1# and CD2# pins.

Bits 7:4 — Management IRQ

Bit 7	Bit 6	Bit 5	Bit 4	Interrupt Pin
0	0	0	0	IRQ disabled
0	0	0	1	IRQ1 for PCI/Way operation, Reserved for others
0	0	1	0	SMI for PCI/Way operation, Reserved for others
0	0	1	1	IRQ3
0	1	0	0	IRQ4
0	1	0	1	IRQ5
0	1	1	0	IRQ6 for PCI/Way operation, Reserved for others
0	1	1	1	IRQ7
1	0	0	0	IRQ8 for PCI/Way operation, Reserved for others
1	0	0	1	IRQ9
1	0	1	0	IRQ10
1	0	1	1	IRQ11
1	1	0	0	IRQ12
1	1	0	1	IRQ13 for PCI/Way operation, Reserved for others
1	1	1	0	IRQ14
1	1	1	1	IRQ15

These bits determine which interrupt pin is used for card status change management interrupts in serial interrupt modes. In PCI Interrupt Signalling mode, management interrupts are signalled on INTA# for socket A and INTB# for socket B. If the RI_OUT feature is enabled on INTB#, all socket B card and management interrupts directed to INTB# are rerouted to INTA#.

8.7 Mapping Enable

Register Name: Mapping Enable						Register Per: socket	
I/O Index: 06h						Register Compatibility Type: 365	
Memory Offset: 806h							
Bit 7	Bit 6	Bit 5	Bit 4	Bit 3	Bit 2	Bit 1	Bit 0
I/O Map 1 Enable	I/O Map 0 Enable	Compatibility	Memory Map 4 Enable	Memory Map 3 Enable	Memory Map 2 Enable	Memory Map 1 Enable	Memory Map 0 Enable
R/W:0	R/W:0	R:0	R/W:0	R/W:0	R/W:0	R/W:0	R/W:0

Bit 0 — Memory Map 0 Enable

0	Memory Window Mapping registers for Memory Window 0 disabled.
1	Memory Window Mapping registers for Memory Window 0 enabled.

When this bit is '1', the **Memory Window Mapping** registers for Memory Window 0 are enabled and the controller responds to memory accesses in the memory space defined by those registers.

Bit 1 — Memory Map 1 Enable

0	Memory Window Mapping registers for Memory Window 1 disabled.
1	Memory Window Mapping registers for Memory Window 1 enabled.

When this bit is '1', the **Memory Window Mapping** registers for Memory Window 1 are enabled and the controller responds to memory accesses in the memory space defined by those registers.

Bit 2 — Memory Map 2 Enable

0	Memory Window Mapping registers for Memory Window 2 disabled.
1	Memory Window Mapping registers for Memory Window 2 enabled.

When this bit is '1', the **Memory Window Mapping** registers for Memory Window 2 are enabled and the controller responds to memory accesses in the memory space defined by those registers.

Bit 3 — Memory Map 3 Enable

0	Memory Window Mapping registers for Memory Window 3 disabled.
1	Memory Window Mapping registers for Memory Window 3 enabled.

When this bit is '1', the **Memory Window Mapping** registers for Memory Window 3 are enabled and the controller responds to memory accesses in the memory space defined by those registers.

Bit 4 — Memory Map 4 Enable

0	Memory Window Mapping registers for Memory Window 4 disabled.
1	Memory Window Mapping registers for Memory Window 4 enabled.

When this bit is '1', the **Memory Window Mapping** registers for Memory Window 4 are enabled and the controller responds to memory accesses in the memory space defined by those registers.

Bit 5 — Compatibility Bit

Bit 6 — I/O Map 0 Enable

0	I/O Window Mapping registers for I/O Window 0 disabled.
1	I/O Window Mapping registers for I/O Window 0 enabled.

When this bit is '1', the **I/O Window Mapping** registers for I/O Window 0 are enabled and the controller responds to I/O accesses in the I/O space defined by those registers.

Bit 7 — I/O Map 1 Enable

0	I/O Window Mapping registers for I/O Window 1 disabled.
1	I/O Window Mapping registers for I/O Window 1 enabled.

When this bit is '1', the **I/O Window Mapping** registers for I/O Window 1 are enabled and the controller responds to I/O accesses in the I/O space defined by those registers.

9. WINDOW MAPPING REGISTERS

Table 9-1. Window Mapping Registers Quick Reference

Register Name	I/O Index	Memory Offset	Page Number
I/O Window Mapping Registers			
I/O Window Control	07h	807h	105
System I/O Map 0–1 Start Address Low	08h, 0Ch	808h, 80Ch	107
System I/O Map 0–1 Start Address High	09h, 0Dh	809h, 80Dh	107
System I/O Map 0–1 End Address Low	0Ah, 0Eh	80Ah, 80Eh	108
System I/O Map 0–1 End Address High	0Bh, 0Fh	80Bh, 80Fh	108
Card I/O Map 0–1 Offset Address Low	36h, 38h	836h, 838h	109
Card I/O Map 0–1 Offset Address High	37h, 39h	837h, 839h	109
Memory Window Mapping Registers			
System Memory Map 0–4 Start Address Low	10h, 18h, 20h, 28h, 30h	810h, 818h, 820h, 828h, 830h	110
System Memory Map 0–4 Start Address High	11h, 19h, 21h, 29h, 31h	811h, 819h, 821h, 829h, 831h	111
System Memory Map 0–4 End Address Low	12h, 1Ah, 22h, 2Ah, 32h	812h, 81Ah, 822h, 82Ah, 832h	112
System Memory Map 0–4 End Address High	13h, 1Bh, 23h, 2Bh, 33h	813h, 81Bh, 823h, 82Bh, 833h	113
Card Memory Map 0–4 Offset Address Low	14h, 1Ch, 24h, 2Ch, 34h	814h, 81Ch, 824h, 82Ch, 834h	114
Card Memory Map 0–4 Offset Address High	15h, 1Dh, 25h, 2Dh, 35h	815h, 81Dh, 825h, 82Dh, 835h	115

Chapter 9 and Chapter 10 discuss the window mapping technique for PC Card application. Chapter 9 discusses the conventional or standard method for mapping windows. This method is featured in all earlier versions of Cirrus Logic PC Card products and is also 82365SL-compatible. This method of window mapping uses seven windows to access the memory and I/O space of the PC Card. The seven windows consist of two windows dedicated to the I/O space and five windows dedicated to the memory space.

For clarity, labels that describe the window mapping registers are consistent with those in earlier data sheets.

NOTE: As of this writing, only the Standard Mapping method is used by PC Card software vendors.

Chapter 10 describes another technique for mapping the seven windows, this is called the General Mapping method. The General Mapping method allows for the flexibility to map any of the seven windows as either a memory window or an I/O window. Additional flexibility allows mapping from PCI memory space or PCI I/O space to PC Card memory space or PC Card I/O space. This is shown in Table 9-2.

NOTE: The General Mapping method is not currently used by PC Card software vendors.

Table 9-2 shows the different registers that have to be programmed to use the various flavors of the Standard and General Mapping methods.

Table 9-2. Window Mapping Registers

Window Type Select	PCI Space Control	PC Card Space Control	PCI Bus	PC Card	Window Configuration
Reset to '0'	Don't Care	Don't Care	I/O	I/O	Standard Mapping
Reset to '0'	Don't Care	Don't Care	Memory	Memory	Standard Mapping
Set to '1'	Set to '1'	Set to '1'	I/O	I/O	General Mapping
Set to '1'	Set to '1'	Reset to '0'	I/O	Memory	General Mapping
Set to '1'	Reset to '0'	Reset to '0'	Memory	Memory	General Mapping
Set to '1'	Reset to '0'	Set to '1'	Memory	I/O	General Mapping

The **General Window Mapping** registers are first presented describing the functionality of the registers when configured in I/O mode. Thereafter, the same register functionality is described when configured in Memory mode. This facilitates understanding since the bit assignments and definitions of these registers are different in the I/O mode and Memory mode.

NOTE: A combination of the Standard Mapping method and General Mapping method can be used.

9.1 I/O Window Mapping Registers

9.1.1 I/O Window Control

Register Name: I/O Window Control						Register Per: socket	
I/O Index: 07h						Register Compatibility Type: 365	
Memory Offset: 807h							
Bit 7	Bit 6	Bit 5	Bit 4	Bit 3	Bit 2	Bit 1	Bit 0
Timing Register Select 1	Compatibility Bit	Auto-Size I/O Window 1	I/O Window 1 Size	Timing Register Select 0	Compatibility Bit	Auto-Size I/O Window 0	I/O Window 0 Size
R/W:0	R/W:0	R/W:0	R/W:0	R/W:0	R/W:0	R/W:0	R/W:0

Bit 0 — I/O Window 0 Size

0	8-bit data path to I/O Window 0.
1	16-bit data path to I/O Window 0.

When bit 1 of this register is '0', this bit determines the width of the data path for I/O Window 0 accesses to the card. When bit 1 is '1', this bit is ignored.

Bit 1 — Auto-Size I/O Window 0

0	I/O Window 0 Size (see bit 0 of this register) determines the data path for I/O Window 0 accesses.
1	The data path to I/O Window 0 is determined by the IOIS16# signal returned by the card.

This bit determines the width of the data path for I/O Window 0 accesses to the card. Note that when this bit is '1', the IOIS16# signal determines the width of the data path to the card.

Bit 2 — Compatibility Bit

Bit 3 — Timing Register Select 0

0	Accesses made with timing specified in Timer Set 0 registers.
1	Accesses made with timing specified in Timer Set 1 registers.

This bit determines the access timing specification for I/O Window 0.

Bit 4 — I/O Window 1 Size

0	8-bit data path to I/O Window 1.
1	16-bit data path to I/O Window 1.

When bit 5 of this register is '0', this bit determines the width of the data path for I/O Window 1 accesses to the card. When bit 5 is '1', this bit is ignored.

Bit 5 — Auto-Size I/O Window 1

0	I/O Window 1 Size (see bit 4 of this register) determines the data path for I/O Window 1 accesses.
1	The data path to I/O Window 1 is determined based on IOIS16# returned by the card.

This bit determines the width of the data path for I/O Window 1 accesses to the card. Note that when this bit is '1', the IOIS16# signal determines the width of the data path to the card.

Bit 6 — Compatibility Bit**Bit 7 — Timing Register Select 1**

0	Accesses made with timing specified in Timer Set 0 .
1	Accesses made with timing specified in Timer Set 1 .

This bit determines the access timing specification for I/O Window 1.

9.1.2 System I/O Map 0–1 Start Address Low

Register Name: System I/O Map 0–1 Start Address Low						Register Per: socket	
I/O Index: 08h, 0Ch						Register Compatibility Type: 365	
Memory Offset: 808h, 80Ch							
Bit 7	Bit 6	Bit 5	Bit 4	Bit 3	Bit 2	Bit 1	Bit 0
Start Address 7:0							
R/W:00000000							

There are two separate **System I/O Map Start Address Low** registers, each with identical fields. These registers are located at the following indexes:

Index (Socket A)	Register
08h	System I/O Map 0 Start Address Low
0Ch	System I/O Map 1 Start Address Low

Bits 7:0 — Start Address 7:0

This register contains the least-significant byte of the address that specifies where in the I/O space the corresponding I/O map begins. I/O accesses that are equal to or above this address and equal to or below the corresponding System I/O Map End Address are mapped into the I/O space of the corresponding PC Card.

The most-significant byte is located in the **System I/O Map 0–1 Start Address High** register.

9.1.3 System I/O Map 0–1 Start Address High

Register Name: System I/O Map 0–1 Start Address High						Register Per: socket	
I/O Index: 09h, 0Dh						Register Compatibility Type: 365	
Memory Offset: 809h, 80Dh							
Bit 7	Bit 6	Bit 5	Bit 4	Bit 3	Bit 2	Bit 1	Bit 0
Start Address 15:8							
R/W:00000000							

There are two separate **System I/O Map Start Address High** registers, each with identical fields. These registers are located at the following indexes:

Index (Socket A)	Register
09h	System I/O Map 0 Start Address High
0Dh	System I/O Map 1 Start Address High

Bits 7:0 — Start Address 15:8

This register contains the most-significant byte of the Start Address. See the description of the Start Address field associated with bits 7:0 of the **System I/O Map 0–1 Start Address Low** register (on [page 107](#)).

9.1.4 System I/O Map 0–1 End Address Low

<i>Register Name:</i> System I/O Map 0–1 End Address Low <i>I/O Index:</i> 0Ah, 0Eh <i>Memory Offset:</i> 80Ah, 80Eh						<i>Register Per:</i> socket <i>Register Compatibility Type:</i> 365	
Bit 7	Bit 6	Bit 5	Bit 4	Bit 3	Bit 2	Bit 1	Bit 0
End Address 7:0							
R/W:00000000							

There are two separate **System I/O Map End Address Low** registers, each with identical fields. These registers are located at the following indexes:

Index (Socket A)	Register
0Ah	System I/O Map 0 End Address Low
0Eh	System I/O Map 1 End Address Low

Bits 7:0 — End Address 7:0

This register contains the least-significant byte of the address that specifies where in the I/O space the corresponding I/O map ends. I/O accesses that are equal to or below this address and equal to or above the corresponding System I/O Map Start Address are mapped into the I/O space of the corresponding PC Card.

The most-significant byte is located in the **System I/O Map 0–1 End Address High** register.

9.1.5 System I/O Map 0–1 End Address High

<i>Register Name:</i> System I/O Map 0–1 End Address High <i>I/O Index:</i> 0Bh, 0Fh <i>Memory Offset:</i> 80Bh, 80Fh						<i>Register Per:</i> socket <i>Register Compatibility Type:</i> 365	
Bit 7	Bit 6	Bit 5	Bit 4	Bit 3	Bit 2	Bit 1	Bit 0
End Address 15:8							
R/W:00000000							

There are two separate **System I/O Map End Address High** registers, each with identical fields. These registers are located at the following indexes:

Index (Socket A)	Register
0Bh	System I/O Map 0 End Address High
0Fh	System I/O Map 1 End Address High

Bits 7:0 — End Address 15:8

This register contains the most-significant byte of the End Address. See the description of the End Address field associated with bits 7:0 of the **System I/O Map 0–1 End Address Low** register (on [page 108](#)).

9.1.6 Card I/O Map 0–1 Offset Address Low

<i>Register Name:</i> Card I/O Map 0–1 Offset Address Low <i>I/O Index:</i> 36h, 38h <i>Memory Offset:</i> 836h, 838h							<i>Register Per:</i> socket <i>Register Compatibility Type:</i> ext.
Bit 7	Bit 6	Bit 5	Bit 4	Bit 3	Bit 2	Bit 1	Bit 0
Offset Address 7:1							Compatibility Bit ^a
R/W:0000000							R/W:0

^a This bit must be programmed to '0'. This compatibility bit does not affect I/O offset address.

There are two separate **Card I/O Map Offset Address Low** registers, each with identical fields. These registers are located at the following indexes:

Index (Socket A)	Register
36h	Card I/O Map 0 Offset Address Low
38h	Card I/O Map 1 Offset Address Low

Bits 7:1 — Offset Address 7:1

This register contains the least-significant byte of the quantity that is added to the system I/O address to determine where in the PC Card's I/O map the I/O access occurs. The CL-PD6833 internally defines bit 0 of offset address as '0'.

The most-significant byte is located in the **Card I/O Map 0–1 Offset Address High** register.

Bit 0 — Compatibility Bit

This bit must be programmed to '0'. It does not affect the I/O offset address.

9.1.7 Card I/O Map 0–1 Offset Address High

<i>Register Name:</i> Card I/O Map 0–1 Offset Address High <i>I/O Index:</i> 37h, 39h <i>Memory Offset:</i> 837h, 839h							<i>Register Per:</i> socket <i>Register Compatibility Type:</i> ext.
Bit 7	Bit 6	Bit 5	Bit 4	Bit 3	Bit 2	Bit 1	Bit 0
Offset Address 15:8							
R/W:00000000							

There are two separate **Card I/O Map Offset Address High** registers, each with identical fields. These registers are located at the following indexes:

Index (Socket A)	Card I/O Map Offset Address High
37h	Card I/O Map 0 Offset Address High
39h	Card I/O Map 1 Offset Address High

Bits 7:0 — Offset Address 15:8

This register contains the most-significant byte of the offset address. See the description of the End Address field associated with bits 7:1 of the **Card I/O Map 0–1 Offset Address Low** register (on [page 109](#)).

9.2 Memory Window Mapping Registers

The following information about memory window mapping is important:

- The Memory Window Mapping registers determine where in the PCI memory space and PC Card memory space accesses occur. There are five memory windows that can be used independently.
- The memory windows are enabled and disabled using the **Mapping Enable** register.
- To specify where in the PCI space a memory window is mapped, start and end addresses are specified. A memory window is selected whenever the appropriate Memory Map Enable bit is set and the following conditions are true:
 - The PCI address is greater than or equal to the appropriate **System Memory Map Start Address** register (see [Section 9.2.1](#)).
 - The PCI address is less than or equal to the appropriate **System Memory Map End Address** register (see [Section 9.2.3](#)).
 - The **System Memory Map Upper Address** register is equal to the upper PCI address.
- Start and end addresses are specified with PCI Address bits 31:12. This sets the minimum size of a memory window to 4 Kbytes. Memory windows are specified in the PCI memory address space.
- To ensure proper operation, none of the memory windows can overlap in the PCI address space.

9.2.1 System Memory Map 0–4 Start Address Low

<i>Register Name:</i> System Memory Map 0–4 Start Address Low					<i>Register Per:</i> socket		
<i>I/O Index:</i> 10h, 18h, 20h, 28h, 30h					<i>Register Compatibility Type:</i> 365		
<i>Memory Offset:</i> 810h, 818h, 820h, 828h, 830h							
Bit 7	Bit 6	Bit 5	Bit 4	Bit 3	Bit 2	Bit 1	Bit 0
Start Address 19:12							
R/W:00000000							

There are five separate **System Memory Map Start Address Low** registers, each with identical fields. These registers are located at the following indexes:

Index (Socket A)	Register
10h	System Memory Map 0 Start Address Low
18h	System Memory Map 1 Start Address Low
20h	System Memory Map 2 Start Address Low
28h	System Memory Map 3 Start Address Low
30h	System Memory Map 4 Start Address Low

Bits 7:0 — Start Address 19:12

This register contains the least-significant byte of the address that specifies where in the memory space the corresponding memory map begins. Memory accesses that are equal to or above this address and equal to or below the corresponding System Memory Map End Address are mapped into the memory space of the corresponding PC Card.

The most-significant four bits are located in the **System Memory Map 0–4 Start Address High** register.

9.2.2 System Memory Map 0–4 Start Address High

<i>Register Name:</i> System Memory Map 0–4 Start Address High <i>I/O Index:</i> 11h, 19h, 21h, 29h, 31h <i>Memory Offset:</i> 811h, 819h, 821h, 829h, 831h				<i>Register Per:</i> socket <i>Register Compatibility Type:</i> 365			
Bit 7	Bit 6	Bit 5	Bit 4	Bit 3	Bit 2	Bit 1	Bit 0
Window Data Size	Compatibility Bit	Scratchpad Bits		Start Address 23:20			
R/W:0	R/W:0	R/W:00		R/W:0000			

There are five separate **System Memory Map Start Address High** registers, each with identical fields. These registers are located at the following indexes:

Index (Socket A)	Register
11h	System Memory Map 0 Start Address High
19h	System Memory Map 1 Start Address High
21h	System Memory Map 2 Start Address High
29h	System Memory Map 3 Start Address High
31h	System Memory Map 4 Start Address High

Bits 3:0 — Start Address 23:20

This field contains the most-significant four bits of the Start Address. See the description of the Start Address field associated with bits 7:0 of the **System Memory Map 0–4 Start Address Low** register (on [page 110](#)).

Bits 5:4 — Scratchpad Bits

Bit 6 — Compatibility Bit

Bit 7 — Window Data Size

0	8-bit data path to the card.
1	16-bit data path to the card.

This bit determines the data path size to the card.

9.2.3 System Memory Map 0–4 End Address Low

<i>Register Name:</i> System Memory Map 0–4 End Address Low				<i>Register Per:</i> socket			
<i>I/O Index:</i> 12h, 1Ah, 22h, 2Ah, 32h				<i>Register Compatibility Type:</i> 365			
<i>Memory Offset:</i> 812h, 81Ah, 822h, 82Ah, 832h							
<i>Bit 7</i>	<i>Bit 6</i>	<i>Bit 5</i>	<i>Bit 4</i>	<i>Bit 3</i>	<i>Bit 2</i>	<i>Bit 1</i>	<i>Bit 0</i>
End Address 19:12							
R/W:00000000							

There are five separate **System Memory Map End Address Low** registers, each with identical fields. These registers are located at the following indexes:

Index (Socket A)	Register
12h	System Memory Map 0 End Address Low
1Ah	System Memory Map 1 End Address Low
22h	System Memory Map 2 End Address Low
2Ah	System Memory Map 3 End Address Low
32h	System Memory Map 4 End Address Low

Bits 7:0 — End Address 19:12

This register contains the least-significant byte of the address that specifies where in the memory space the corresponding memory map ends. Memory accesses that are equal to or below this address and equal to or above the corresponding System Memory Map Start Address are mapped into the memory space of the corresponding PC Card.

The most-significant four bits are located in the **System Memory Map 0–4 End Address High** register.

9.2.4 System Memory Map 0–4 End Address High

<i>Register Name:</i> System Memory Map 0–4 End Address High <i>I/O Index:</i> 13h, 1Bh, 23h, 2Bh, 33h <i>Memory Offset:</i> 813h, 81Bh, 823h, 82Bh, 833h				<i>Register Per:</i> socket <i>Register Compatibility Type:</i> 365			
Bit 7	Bit 6	Bit 5	Bit 4	Bit 3	Bit 2	Bit 1	Bit 0
Card Timer Select		Scratchpad Bits		End Address 23:20			
R/W:00		R/W:00		R/W:0000			

There are five separate **System Memory Map End Address High** registers, each with identical fields. These registers are located at the following indexes:

Index (Socket A)	Register
13h	System Memory Map 0 End Address High
1Bh	System Memory Map 1 End Address High
23h	System Memory Map 2 End Address High
2Bh	System Memory Map 3 End Address High
33h	System Memory Map 4 End Address High

Bits 3:0 — End Address 23:20

This field contains the most-significant four bits of the End Address. See the description of the End Address field associated with bits 7:0 of the **System Memory Map 0–4 End Address Low** register. Note that the upper memory addresses are stored in the **System Memory Map Upper Address** register.

Bits 5:4 — Scratchpad Bits

Bits 7:6 — Card Timer Select

Bit 7	Bit 6	Timer Set Select
0	0	Selects Timer Set 0
0	1	Selects Timer Set 1
1	0	Selects Timer Set 1
1	1	Selects Timer Set 1

This field selects the **Timer Set** registers to control socket timing for card accesses in this window address range. This field selects the timer set. Timer Set 0 and 1 reset to values compatible with PC Card standards. Mapping of bits 7:6 to Timer Set 0 and 1, as shown, is done for software compatibility with other older ISA-bus based PC Card host adapters that use ISA bus wait states instead of **Timer Set** registers.

9.2.5 Card Memory Map 0–4 Offset Address Low

<i>Register Name:</i> Card Memory Map 0–4 Offset Address Low				<i>Register Per:</i> socket			
<i>I/O Index:</i> 14h, 1Ch, 24h, 2Ch, 34h				<i>Register Compatibility Type:</i> 365			
<i>Memory Offset:</i> 814h, 81Ch, 824h, 82Ch, 834h							
<i>Bit 7</i>	<i>Bit 6</i>	<i>Bit 5</i>	<i>Bit 4</i>	<i>Bit 3</i>	<i>Bit 2</i>	<i>Bit 1</i>	<i>Bit 0</i>
Offset Address 19:12							
R/W:00000000							

There are five separate **Card Memory Map Offset Address Low** registers, each with identical fields. These registers are located at the following indexes:

Index (Socket A)	Register
14h	Card Memory Map 0 Offset Address Low
1Ch	Card Memory Map 1 Offset Address Low
24h	Card Memory Map 2 Offset Address Low
2Ch	Card Memory Map 3 Offset Address Low
34h	Card Memory Map 4 Offset Address Low

Bits 7:0 — Offset Address 19:12

This register contains the least-significant byte of the quantity that is added to the system memory address that determines where in the PC Card memory map the memory access occurs.

The most-significant six bits are located in the **Card Memory Map 0–4 Offset Address High** register.

9.2.6 Card Memory Map 0–4 Offset Address High

Register Name: Card Memory Map 0–4 Offset Address High					Register Per: socket		
I/O Index: 15h, 1Dh, 25h, 2Dh, 35h					Register Compatibility Type: 365		
Memory Offset: 815h, 81Dh, 825h, 82Dh, 835h							
Bit 7	Bit 6	Bit 5	Bit 4	Bit 3	Bit 2	Bit 1	Bit 0
Write Protect	REG Setting	Offset Address 25:20					
R/W:0	R/W:0	R/W:000000					

There are five separate **Card Memory Map Offset Address High** registers, each with identical fields. These registers are located at the following indexes:

Index (Socket A)	Register
15h	Card Memory Map 0 Offset Address High
1Dh	Card Memory Map 1 Offset Address High
25h	Card Memory Map 2 Offset Address High
2Dh	Card Memory Map 3 Offset Address High
35h	Card Memory Map 4 Offset Address High

Bits 5:0 — Offset Address 25:20

This field contains the most-significant six bits of the Offset Address. See the description of the Offset Address field associated with bits 7:0 of the **Card Memory Map 0–4 Offset Address Low** register (on [page 114](#)).

Bit 6 — REG Setting

0	REG# is not active for accesses made through this window.
1	REG# is active for accesses made through this window.

This bit determines whether REG# is active for accesses made through this window. CIS (card information structure) memory is accessed by setting this bit to '1'.

Bit 7 — Write Protect

0	Writes to the card through this window are allowed.
1	Writes to the card through this window are not allowed.

This bit determines whether writes to the card through this window are allowed.

Notes

10. GENERAL WINDOW MAPPING REGISTERS

Table 10-1. General Window Mapping Registers Quick Reference

Register Name	I/O Index	Memory Offset	Page Number
General Mapping Registers for I/O Mode			
Gen Map 0–6 Start Address Low (I/O)	08h, 0Ch, 10h, 18h, 20h, 28h, 30h	808h, 80Ch, 810h, 818h, 820h, 828h, 830h	119
Gen Map 0–6 Start Address High (I/O)	09h, 0Dh, 11h, 19h, 21h, 29h, 31h	809h, 80Dh, 811h, 819h, 821h, 829h, 831h	120
Gen Map 0–6 End Address Low (I/O)	0Ah, 0Eh, 12h, 1Ah, 22h, 2Ah, 32h	80Ah, 80Eh, 812h, 81Ah, 822h, 82Ah, 832h	121
Gen Map 0–6 End Address High (I/O)	0Bh, 0Fh, 13h, 1Bh, 23h, 2Bh, 33h	80Bh, 80Fh, 813h, 81Bh, 823h, 82Bh, 833h	122
Gen Map 0–6 Offset Address Low (I/O)	14h, 1Ch, 24h, 2Ch, 34h, 36h, 38h	814h, 81Ch, 824h, 82Ch, 834h, 836h, 838h	123
Gen Map 0–6 Offset Address High (I/O)	15h, 1Dh, 25h, 2Dh, 35h, 37h, 39h	815h, 81Dh, 825h, 82Dh, 835h, 837h, 839h	124
General Mapping Register for Memory Mode			
Gen Map 0–6 Start Address Low (Memory)	08h, 0Ch, 10h, 18h, 20h, 28h, 30h	808h, 80Ch, 810h, 818h, 820h, 828h, 830h	125
Gen Map 0–6 Start Address High (Memory)	09h, 0Dh, 11h, 19h, 21h, 29h, 31h	809h, 80Dh, 811h, 819h, 821h, 829h, 831h	126
Gen Map 0–6 End Address Low (Memory)	0Ah, 0Eh, 12h, 1Ah, 22h, 2Ah, 32h	80Ah, 80Eh, 812h, 81Ah, 822h, 82Ah, 832h	127
Gen Map 0–6 End Address High (Memory)	0Bh, 0Fh, 13h, 1Bh, 23h, 2Bh, 33h	80Bh, 80Fh, 813h, 81Bh, 823h, 82Bh, 833h	128
Gen Map 0–6 Offset Address Low (Memory)	14h, 1Ch, 24h, 2Ch, 34h, 36h, 38h	814h, 81Ch, 824h, 82Ch, 834h, 836h, 838h	129
Gen Map 0–6 Offset Address High (Memory)	15h, 1Dh, 25h, 2Dh, 35h, 37h, 39h	815h, 81Dh, 825h, 82Dh, 835h, 837h, 839h	130

The following information about I/O window mapping is important:

- The **I/O Window Mapping** registers determine where in the PCI I/O space and PC Card I/O space accesses occur. On reset, there are two I/O windows that can be used independently.
- In addition, depending on the **PC Card Space Control**, **PCI Space Control**, and **Window Type Select** registers, all mapping registers can be defined as **I/O Window Mapping** registers. This provides five additional I/O windows that can be used independently. A total of seven I/O windows can be realized.
- All the **I/O Window Mapping** registers have dual functionality. The functions are determined by the **PC Card Space Control**, **PCI Space Control**, and **Window Type Select** registers. At reset the **Window Type Select** register is set to 00h. This configures the I/O and memory windows to be compatible with the CL-PD672X products. When a bit in the **Window Type Select** register is set, the corresponding window can be programmed using the **PC Card Space Control** and **PCI Space Control** registers to respond to I/O or memory commands on the PCI bus and to present these cycles to the PC Card 16 socket as either memory or I/O cycles. To facilitate this operation anytime, a bit is set in the **Window Type Select** register. The attributes for Timer selection and the size of the data for a window are programmed in the **Gen Map Extra Control** registers.
- The I/O windows are enabled and disabled using the **Mapping Enable** register (see [page 101](#)).
- To specify where in the PCI space an I/O window is mapped, start and end addresses are specified. An I/O window is selected whenever the appropriate **Gen Map Enable** bit is set and the following conditions are true:
 - The PCI address is greater than or equal to the appropriate **Gen Map Start Address** register.
 - The PCI address is less than or equal to the appropriate **Gen Map End Address** register.
 - The upper 16 bits of the PCI address are all '0's.
- To specify where in the PCI space a memory window is mapped, start and end addresses are specified. A memory window is selected whenever the appropriate Memory Map Enable bit is set and the following conditions are true:
 - The PCI address is greater than or equal to the appropriate **System Memory Map Start Address** register (see [page 110](#)).
 - The PCI address is less than or equal to the appropriate **System Memory Map End Address** register (see [page 112](#)).
 - The **System Memory Map Upper Address** register is equal to the upper PCI address.
 - Start and end addresses are specified with PCI Address bits 31:12. This sets the minimum size of a memory window to 4 Kbytes. Memory windows are specified in the PCI memory address space.
- To ensure proper operation, none of the I/O windows can overlap in the PCI address space.
- In this specification, references to I/O Window 0 pertain to Gen Map 5 and I/O Window 1 corresponds to Gen Map 6. Memory Windows 0–4 correspond to Gen Map 0–4.

CAUTION: Be sure that the I/O windows do not map to the **I/O Base Address** register programmed at offset 44h in the configuration space.

10.1 General Mapping Registers for I/O Mode

10.1.1 Gen Map 0–6 Start Address Low (I/O)

Register Name: Gen Map 0–6 Start Address Low (I/O)						Register Per: socket	
I/O Index: 08h, 0Ch, 10h, 18h, 20h, 28h, 30h						Register Compatibility Type: 365	
Memory Offset: 808h, 80Ch, 810h, 818h, 820h, 828h, 830h							
Bit 7	Bit 6	Bit 5	Bit 4	Bit 3	Bit 2	Bit 1	Bit 0
Start Address 7:0 (I/O)							
R/W:00000000							

There are seven separate **Gen Map Start Address Low** registers, each with identical fields. These registers are located at the following indexes:

Index	Memory Offset	Gen Map Start Address Low	Default Operation
08h	808h	Gen Map 5 Start Address Low	I/O Window 0
0Ch	80Ch	Gen Map 6 Start Address Low	I/O Window 1
10h	810h	Gen Map 0 Start Address Low	Memory Window 0
18h	818h	Gen Map 1 Start Address Low	Memory Window 1
20h	820h	Gen Map 2 Start Address Low	Memory Window 2
28h	828h	Gen Map 3 Start Address Low	Memory Window 3
30h	830h	Gen Map 4 Start Address Low	Memory Window 4

Bits 7:0 — Start Address 7:0 (I/O)

This register contains the least-significant byte of the address that specifies where the I/O space corresponding to the I/O map begins. I/O accesses that are equal or above this address and equal or below the corresponding **Gen Map End Address** are mapped into the I/O or memory space of the corresponding PC Card depending on the appropriate bit of the **PC Card Space Control** register.

10.1.2 Gen Map 0–6 Start Address High (I/O)

<i>Register Name:</i> Gen Map 0–6 Start Address High (I/O)				<i>Register Per:</i> socket			
<i>I/O Index:</i> 09h, 0Dh, 11h, 19h, 21h, 29h, 31h				<i>Register Compatibility Type:</i> 365			
<i>Memory Offset:</i> 809h, 80Dh, 811h, 819h, 821h, 829h, 831h							
<i>Bit 7</i>	<i>Bit 6</i>	<i>Bit 5</i>	<i>Bit 4</i>	<i>Bit 3</i>	<i>Bit 2</i>	<i>Bit 1</i>	<i>Bit 0</i>
Start Address 15:8 (I/O)							
R/W:00000000							

There are seven separate **Gen Map Start Address High** registers, each with identical fields. These registers are located at the following indexes:

Index	Memory Offset	Gen Map Start Address High	Default Operation
09h	809h	Gen Map 5 Start Address High	I/O Window 0
0Dh	80Dh	Gen Map 6 Start Address High	I/O Window 1
11h	811h	Gen Map 0 Start Address High	Memory Window 0
19h	819h	Gen Map 1 Start Address High	Memory Window 1
21h	821h	Gen Map 2 Start Address High	Memory Window 2
29h	829h	Gen Map 3 Start Address High	Memory Window 3
31h	831h	Gen Map 4 Start Address High	Memory Window 4

Bits 7:0 — Start Address 15:8 (I/O)

This register contains the most-significant byte of the address of the I/O space Start Address.

10.1.3 Gen Map 0–6 End Address Low (I/O)

Register Name: Gen Map 0–6 End Address Low (I/O)				Register Per: socket			
I/O Index: 0Ah, 0Eh, 12h, 1Ah, 22h, 2Ah, 32h				Register Compatibility Type: 365			
Memory Offset: 80Ah, 80Eh, 812h, 81Ah, 822h, 82Ah, 832h							
Bit 7	Bit 6	Bit 5	Bit 4	Bit 3	Bit 2	Bit 1	Bit 0
End Address 7:0 (I/O)							
R/W:00000000							

There are seven separate **Gen Map End Address Low** registers, each with identical fields. These registers are located at the following indexes:

Index	Memory Offset	Gen Map End Address Low	Default Operation
0Ah	80Ah	Gen Map 5 End Address Low	I/O Window 0
0Eh	80Eh	Gen Map 6 End Address Low	I/O Window 1
12h	812h	Gen Map 0 End Address Low	Memory Window 0
1Ah	81Ah	Gen Map 1 End Address Low	Memory Window 1
22h	822h	Gen Map 2 End Address Low	Memory Window 2
2Ah	82Ah	Gen Map 3 End Address Low	Memory Window 3
32h	832h	Gen Map 4 End Address Low	Memory Window 4

Bits 7:0 — End Address 7:0 (I/O)

This register contains the least-significant byte of the address that specifies where the I/O space corresponding to the I/O map ends. I/O accesses that are equal or below this address and equal or above the corresponding **Gen Map Start Address** are mapped into the I/O or memory space of the corresponding PC Card.

10.1.4 Gen Map 0–6 End Address High (I/O)

<i>Register Name:</i> Gen Map 0–6 End Address High (I/O)				<i>Register Per:</i> socket			
<i>I/O Index:</i> 0Bh, 0Fh, 13h, 1Bh, 23h, 2Bh, 33h				<i>Register Compatibility Type:</i> 365			
<i>Memory Offset:</i> 80Bh, 80Fh, 813h, 81Bh, 823h, 82Bh, 833h							
<i>Bit 7</i>	<i>Bit 6</i>	<i>Bit 5</i>	<i>Bit 4</i>	<i>Bit 3</i>	<i>Bit 2</i>	<i>Bit 1</i>	<i>Bit 0</i>
End Address 15:8 (I/O)							
R/W:00000000							

There are seven separate **Gen Map End Address High** registers, each with identical fields. These registers are located at the following indexes:

Index	Memory Offset	Gen Map End Address High	Default Operation
0Bh	80Bh	Gen Map 5 End Address High	I/O Window 0
0Fh	80Fh	Gen Map 6 End Address High	I/O Window 1
13h	813h	Gen Map 0 End Address High	Memory Window 0
1Bh	81Bh	Gen Map 1 End Address High	Memory Window 1
23h	823h	Gen Map 2 End Address High	Memory Window 2
2Bh	82Bh	Gen Map 3 End Address High	Memory Window 3
33h	833h	Gen Map 4 End Address High	Memory Window 4

Bits 7:0 — End Address 15:8 (I/O)

This register contains the most-significant byte of the address of the I/O space End Address.

10.1.5 Gen Map 0–6 Offset Address Low (I/O)

Register Name: Gen Map 0–6 Offset Address Low (I/O) I/O Index: 14h, 1Ch, 24h, 2Ch, 34h, 36h, 38h Memory Offset: 814h, 81Ch, 824h, 82Ch, 834h, 836h, 838h							Register Per: socket Register Compatibility Type: ext.
Bit 7	Bit 6	Bit 5	Bit 4	Bit 3	Bit 2	Bit 1	Bit 0
Offset Address 7:1 (I/O)							0^a
R/W:0000000							R/W:0

^a This bit must be programmed to '0' for I/O offset.

There are seven separate **Gen Map Offset Address Low** registers, each with identical fields. These registers are located at the following indexes:

I/O Index	Memory Offset	Gen Map Offset Address Low	Default Operation
14h	814h	Gen Map 0 Offset Address Low	Memory Window 0
1Ch	81Ch	Gen Map 1 Offset Address Low	Memory Window 1
24h	824h	Gen Map 2 Offset Address Low	Memory Window 2
2Ch	82Ch	Gen Map 3 Offset Address Low	Memory Window 3
34h	834h	Gen Map 4 Offset Address Low	Memory Window 4
36h	836h	Gen Map 5 Offset Address Low	I/O Window 0
38h	838h	Gen Map 6 Offset Address Low	I/O Window 1

Bit 0 — Reserved

This bit must be programmed to '0' for I/O offset.

Bits 7:1 — Offset Address 7:1(I/O)

This register contains the least-significant byte of the quantity that is added to the system address to determine where in the PC Card's I/O map the I/O access occurs.

10.1.6 Gen Map 0–6 Offset Address High (I/O)

<i>Register Name:</i> Gen Map 0–6 Offset Address High (I/O)				<i>Register Per:</i> socket			
<i>I/O Index:</i> 15h, 1Dh, 25h, 2Dh, 35h, 37h, 39h				<i>Register Compatibility Type:</i> ext.			
<i>Memory Offset:</i> 815h, 81Dh, 825h, 82Dh, 835h, 837h, 839h							
<i>Bit 7</i>	<i>Bit 6</i>	<i>Bit 5</i>	<i>Bit 4</i>	<i>Bit 3</i>	<i>Bit 2</i>	<i>Bit 1</i>	<i>Bit 0</i>
Offset Address 15:8 (I/O)							
R/W:00000000							

There are seven separate **Gen Map Offset Address High** registers, each with identical fields. These registers are located at the following indexes:

I/O Index	Memory Offset	Gen Map Offset Address High	Default Operation
15h	815h	Gen Map 0 Offset Address High	Memory Window 0
1Dh	81Dh	Gen Map 1 Offset Address High	Memory Window 1
25h	825h	Gen Map 2 Offset Address High	Memory Window 2
2Dh	82Dh	Gen Map 3 Offset Address High	Memory Window 3
35h	835h	Gen Map 4 Offset Address High	Memory Window 4
37h	837h	Gen Map 5 Offset Address High	I/O Window 0
39h	839h	Gen Map 6 Offset Address High	I/O Window 1

Bits 7:0 — Offset Address 15:8 (I/O)

This register contains the most-significant byte of the quantity that is added to the system address to determine where in the PC Card's I/O map the I/O access occurs.

10.2 General Mapping Register for Memory Mode

10.2.1 Gen Map 0–6 Start Address Low (Memory)

Register Name: Gen Map 0–6 Start Address Low (Memory)				Register Per: socket			
I/O Index: 08h, 0Ch, 10h, 18h, 20h, 28h, 30h				Register Compatibility Type: 365			
Memory Offset: 808h, 80Ch, 810h, 818h, 820h, 828h, 830h							
Bit 7	Bit 6	Bit 5	Bit 4	Bit 3	Bit 2	Bit 1	Bit 0
Start Address 19:12 (Memory)							
R/W:00000000							

There are seven separate **Gen Map Start Address Low** registers, each with identical fields. These registers are located at the following indexes:

Index	Memory Offset	Gen Map Start Address Low	Default Operation
08h	808h	Gen Map 5 Start Address Low	I/O Window 0
0Ch	80Ch	Gen Map 6 Start Address Low	I/O Window 1
10h	810h	Gen Map 0 Start Address Low	Memory Window 0
18h	818h	Gen Map 1 Start Address Low	Memory Window 1
20h	820h	Gen Map 2 Start Address Low	Memory Window 2
28h	828h	Gen Map 3 Start Address Low	Memory Window 3
30h	830h	Gen Map 4 Start Address Low	Memory Window 4

Bits 7:0 — Start Address 19:12 (Memory)

This register contains the least-significant byte of the address that specifies where the memory space of the corresponding memory map begins. Memory accesses that are equal or above this address and equal or below the corresponding **Gen Map End Address** are mapped into the I/O or memory space of the corresponding PC Card depending on the appropriate bits of the **PC Card Space Control** and **Window Type Select** registers.

The most-significant byte is located in the **Gen Map 0–6 Start Address High** register.

10.2.2 Gen Map 0–6 Start Address High (Memory)

<i>Register Name: Gen Map 0–6 Start Address High (Memory)</i>				<i>Register Per: socket</i>			
<i>I/O Index: 09h, 0Dh, 11h, 19h, 21h, 29h, 31h</i>				<i>Register Compatibility Type: 365</i>			
<i>Memory Offset: 809h, 80Dh, 811h, 819h, 821h, 829h, 831h</i>							
<i>Bit 7</i>	<i>Bit 6</i>	<i>Bit 5</i>	<i>Bit 4</i>	<i>Bit 3</i>	<i>Bit 2</i>	<i>Bit 1</i>	<i>Bit 0</i>
Reserved	Compatibility Bit	Scratchpad Bits		Start Address 23:20			
R/W:0	R/W:0	R/W:00		R/W:0000			

There are seven separate **Gen Map Start Address High** registers, each with identical fields. These registers are located at the following indexes:

Index	Memory Offset	Gen Map Start Address High	Default Operation
09h	809h	Gen Map 5 Start Address High	I/O Window 0
0Dh	80Dh	Gen Map 6 Start Address High	I/O Window 1
11h	811h	Gen Map 0 Start Address High	Memory Window 0
19h	819h	Gen Map 1 Start Address High	Memory Window 1
21h	821h	Gen Map 2 Start Address High	Memory Window 2
29h	829h	Gen Map 3 Start Address High	Memory Window 3
31h	831h	Gen Map 4 Start Address High	Memory Window 4

Bits 3:0 — Start Address 23:20

This field contains the most-significant four bits of the Memory Start Address.

Bits 5:4 — Scratchpad Bits

Bit 6 — Compatibility Bit

Bit 7 — Reserved

10.2.3 Gen Map 0–6 End Address Low (Memory)

Register Name: Gen Map 0–6 End Address Low (Memory)				Register Per: socket			
I/O Index: 0Ah, 0Eh, 12h, 1Ah, 22h, 2Ah, 32h				Register Compatibility Type: 365			
Memory Offset: 80Ah, 80Eh, 812h, 81Ah, 822h, 82Ah, 832h							
Bit 7	Bit 6	Bit 5	Bit 4	Bit 3	Bit 2	Bit 1	Bit 0
End Address 19:12 (Memory)							
R/W:00000000							

There are seven separate **Gen Map End Address Low** registers, each with identical fields. These registers are located at the following indexes:

Index	Memory Offset	Gen Map End Address Low	Default Operation
0Ah	80Ah	Gen Map 5 End Address Low	I/O Window 0
0Eh	80Eh	Gen Map 6 End Address Low	I/O Window 1
12h	812h	Gen Map 0 End Address Low	Memory Window 0
1Ah	81Ah	Gen Map 1 End Address Low	Memory Window 1
22h	822h	Gen Map 2 End Address Low	Memory Window 2
2Ah	82Ah	Gen Map 3 End Address Low	Memory Window 3
32h	832h	Gen Map 4 End Address Low	Memory Window 4

Bits 7:0 — End Address 19:12 (Memory)

This register contains the least-significant byte of the address that specifies where in the Memory space corresponding to the Memory map ends. Memory accesses that are equal or below this address and equal or above the corresponding **Gen Map Start Address** are mapped into the I/O or memory space of the corresponding PC Card.

The most-significant bits are located in the **Gen Map 0–6 End Address High** register.

10.2.4 Gen Map 0–6 End Address High (Memory)

<i>Register Name: Gen Map 0–6 End Address High (Memory)</i>				<i>Register Per: socket</i>			
<i>I/O Index: 0Bh, 0Fh, 13h, 1Bh, 23h, 2Bh, 33h</i>				<i>Register Compatibility Type: 365</i>			
<i>Memory Offset: 80Bh, 80Fh, 813h, 81Bh, 823h, 82Bh, 833h</i>							
<i>Bit 7</i>	<i>Bit 6</i>	<i>Bit 5</i>	<i>Bit 4</i>	<i>Bit 3</i>	<i>Bit 2</i>	<i>Bit 1</i>	<i>Bit 0</i>
Reserved		Scratchpad Bits		End Address 23:20 (Memory)			
R/W:00		R/W:00		R/W:0000			

There are seven separate **Gen Map End Address High** registers, each with identical fields. These registers are located at the following indexes:

Index	Memory Offset	Gen Map End Address High	Default Operation
0Bh	80Bh	Gen Map 5 End Address High	I/O Window 0
0Fh	80Fh	Gen Map 6 End Address High	I/O Window 1
13h	813h	Gen Map 0 End Address High	Memory Window 0
1Bh	81Bh	Gen Map 1 End Address High	Memory Window 1
23h	823h	Gen Map 2 End Address High	Memory Window 2
2Bh	82Bh	Gen Map 3 End Address High	Memory Window 3
33h	833h	Gen Map 4 End Address High	Memory Window 4

Bits 3:0 — End Address 23:20 (Memory)

This field contains the most-significant four bits of the Memory End Address for registers that default to memory operation.

Bits 5:4 — Scratchpad Bits

Bits 7:6 — Reserved

10.2.5 Gen Map 0–6 Offset Address Low (Memory)

<i>Register Name:</i> Gen Map 0–6 Offset Address Low (Memory)				<i>Register Per:</i> socket			
<i>I/O Index:</i> 14h, 1Ch, 24h, 2Ch, 34h, 36h, 38h				<i>Register Compatibility Type:</i> ext.			
<i>Memory Offset:</i> 814h, 81Ch, 824h, 82Ch, 834h, 836h, 838h							
Bit 7	Bit 6	Bit 5	Bit 4	Bit 3	Bit 2	Bit 1	Bit 0
Offset Address 19:12 (Memory)							
R/W:0000000							

There are seven separate **Gen Map Offset Address Low** registers, each with identical fields. These registers are located at the following indexes:

I/O Index	Memory Offset	Gen Map Offset Address Low	Default Operation
14h	814h	Gen Map 0 Offset Address Low	Memory Window 0
1Ch	81Ch	Gen Map 1 Offset Address Low	Memory Window 1
24h	824h	Gen Map 2 Offset Address Low	Memory Window 2
2Ch	82Ch	Gen Map 3 Offset Address Low	Memory Window 3
34h	834h	Gen Map 4 Offset Address Low	Memory Window 4
36h	836h	Gen Map 5 Offset Address Low	I/O Window 0
38h	838h	Gen Map 6 Offset Address Low	I/O Window 1

Bits 7:0 — Offset Address 19:12 (Memory)

This register contains the least-significant byte of the quantity that is added to the system address that determines where in the PCMCIA card's memory map the memory access occurs.

The most-significant bits are located in the **Gen Map 0–6 Offset Address High** register.

10.2.6 Gen Map 0–6 Offset Address High (Memory)

<i>Register Name:</i> Gen Map 0–6 Offset Address High (Memory) <i>I/O Index:</i> 15h, 1Dh, 25h, 2Dh, 35h, 37h, 39h <i>Memory Offset:</i> 815h, 81Dh, 825h, 82Dh, 835h, 837h, 839h				<i>Register Per:</i> socket <i>Register Compatibility Type:</i> 365			
Bit 7	Bit 6	Bit 5	Bit 4	Bit 3	Bit 2	Bit 1	Bit 0
Write Protect	REG Setting	Offset Address 25:20 (Memory)					
R/W:0	R/W:0	R/W:000000					

There are seven separate **Gen Map Offset Address High** registers, each with identical fields. These registers are located at the following indexes:

I/O Index	Memory Offset	Gen Map Offset Address High	Default Operation
15h	815h	Gen Map 0 Offset Address High	Memory Window 0
1Dh	81Dh	Gen Map 1 Offset Address High	Memory Window 1
25h	825h	Gen Map 2 Offset Address High	Memory Window 2
2Dh	82Dh	Gen Map 3 Offset Address High	Memory Window 3
35h	835h	Gen Map 4 Offset Address High	Memory Window 4
37h	837h	Gen Map 5 Offset Address High	I/O Window 0
39h	839h	Gen Map 6 Offset Address High	I/O Window 1

Bits 5:0 — Offset Address 25:20 (Memory)

This field contains the most-significant six bits of the Memory Offset Address.

Bit 6 — REG Setting

0	REG# (see page 15) is not active for accesses made through this window.
1	REG# is active for accesses made through this window.

This bit determines whether REG# (see [page 15](#)) is active for accesses made through this window. CIS (card information structure) memory is accessed by setting this bit to '1'.

Bit 7 — Write Protect

0	Writes to the card through this window are allowed.
1	Writes to the card through this window are not allowed.

This bit determines whether writes to the card through this window are allowed.

See the description of the Offset Address field associated with bits 7:0 of the **Gen Map 5–6 Offset Address Low** register (on [page 123](#)).

11. EXTENSION REGISTERS

Table 11-1. Extension Registers Quick Reference

Register Name	I/O Index	Memory Offset	Extended Index	Page Number
Misc Control 1	16h	816h	–	132
FIFO Control	17h	817h	–	134
Misc Control 2	1Eh	81Eh	–	136
Chip Information	1Fh	81Fh	–	137
ATA Control	26h	826h	–	138
Extended Index	2Eh, 6Eh	–	–	140
Extended Data	2Fh, 6Fh	–	–	141
Extension Control 1	2Fh	903h	03h	142
Gen Map 0–6 Upper Address (Memory)	2Fh	840h, 841h, 842h, 843h, 844h, 845h, 846h	05h–09h, 20h, 21h	143
Pin Multiplex Control 0 Register — PME_CXT	2Fh	914h	–	144
Pin Multiplex Control 1 Register — PME_CXT	2Fh	915h	–	146
GPIO Output Control	2Fh	918h	18h	147
GPIO Input Control	2Fh	919h	19h	147
GPIO Output Data	2Fh	91Ah	1Ah	148
GPIO Input Data	2Fh	91Bh	1Bh	148
Prefetch Window Register	2Fh	91Ch	1Ch	149
PCI Space Control	2Fh	922h	22h	149
PC Card Space Control	2Fh	923h	23h	150
Window Type Select	2Fh	924h	24h	150
Misc Control 3	2Fh	925h	25h	151
SMBus Socket Power Control Address — PME_CXT	2Fh	926h	26h	153
Gen Map 0–6 Extra Control (I/O)	2Fh	927h–92Dh	27h–2Dh	154
Gen Map 0–6 Extra Control (Memory)	2Fh	927h–92Dh	27h–2Dh	155
Extension Card Status Change	2Fh	92Eh	2Eh	156
Misc Control 4	2Fh	92Fh	2Fh	157
Misc Control 5	2Fh	930h	30h	158
Misc Control 6	2Fh	931h	31h	158

Table 11-1. Extension Registers Quick Reference (cont.)

Register Name	I/O Index	Memory Offset	Extended Index	Page Number
Device Identification and Implementation Scheme				159
Mask Revision Byte	34h	934h	–	159
Product ID Byte	35h	935h	–	160
Device Capability Byte A	36h	936h	–	161
Device Capability Byte B	37h	937h	–	162
Device Implementation Byte A	38h	938h	–	163
Device Implementation Byte B	39h	939h	–	164
Device Implementation Byte C	3Ah	93Ah	–	165
Device Implementation Byte D	3Bh	93Bh	–	166

11.1 Misc Control 1

<i>Register Name:</i> Misc Control 1 <i>I/O Index:</i> 16h <i>Memory Offset:</i> 816h				<i>Register Per:</i> socket <i>Register Compatibility Type:</i> ext.			
Bit 7	Bit 6	Bit 5	Bit 4	Bit 3	Bit 2	Bit 1	Bit 0
Compatibility Bit	Scratchpad Bits		Speaker Enable	Pulse System IRQ Interrupt ^a	Pulse Management Interrupt ^a	V _{CC} 3.3 V — PME_CXT	Multimedia Enable
R/W:0	R/W:00		R/W:0	R/W:0	R/W:0	R/W:0	R/W:0

^a Bits 3:2 are valid only in External Hardware Interrupt Signalling mode.

Bit 0 — Multimedia Enable

0	Socket address lines are normal.
1	Socket address lines A[25:4] are high-impedance.

When this bit is set to '1', the host tristates address lines A[25:4]. This bit has no effect unless the Multimedia Arm bit is set to '1' in Misc Control 3 (see [Section 11.8.4 on page 151](#)).

Bit 1 — V_{CC} 3.3 V — PME_CXT

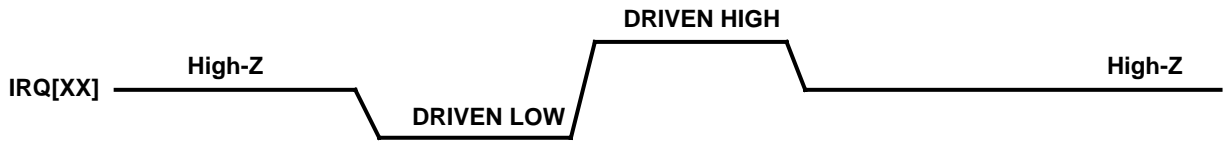
0	5 V activated when card power is to be applied.
1	3 V activated when card power is to be applied.

This bit determines whether 3 V or 5 V is applied to the socket when card power is applied; this bit is used in conjunction with bit 4 of the **Power Control** register. This bit is part of the PME_CXT (PME Context), a set of register bits that do not get reset or initialized if PME Enable is true when the CL-PD6833 changes power states from D3 to D0 through a software PCI Bus Segment reset.

Bit 2 — Pulse Management Interrupt

0	Interrupts are passed to the IRQ[XX] pin as level-sensitive.
1	When an interrupt occurs, the IRQ[XX] pin is driven with the pulse train shown in Figure 11-1 and allows for interrupt sharing.

This bit is valid only in External Hardware Interrupt Signalling mode. This bit selects Level or Pulse mode operation of the IRQ[XX] pin. Note that a clock must be present on PCI_CLK for pulsed interrupts to work. Refer to [Section 15.3.2](#) for more information on interrupt timing.



High-Z = High-impedance

Figure 11-1. Pulse Mode Interrupts

Bit 3 — Pulse System IRQ Interrupt

0	Interrupts are passed to the IRQ[XX] pin as level-sensitive.
1	When an interrupt occurs, the IRQ[XX] pin is driven with the pulse train shown in Figure 11-1 and allows for interrupt sharing.

This bit is valid only in External Hardware Interrupt Signalling mode. This bit selects Level or Pulse mode operation of the IRQ[XX] pins.

Bit 4 — Speaker Enable

0	SPKR_OUT* is high-impedance.
1	SPKR_OUT* is driven from the XNOR of SPKR# from each enabled socket.

This bit determines whether the card SPKR# pin drives SPCR_OUT* (see [page 21](#)).

Bits 6:5 — Scratchpad Bits

Bit 7 — Compatibility Bit

11.2 FIFO Control

<i>Register Name:</i> FIFO Control <i>I/O Index:</i> 17h <i>Memory Offset:</i> 817h				<i>Register Per:</i> socket <i>Register Compatibility Type:</i> ext.			
<i>Bit 7</i>	<i>Bit 6</i>	<i>Bit 5</i>	<i>Bit 4</i>	<i>Bit 3</i>	<i>Bit 2</i>	<i>Bit 1</i>	<i>Bit 0</i>
FIFO Status / Flush FIFO	Disable Memory Posting	Disable I/O Posting	<i>Reserved</i>	CardBus-to- PCI FIFO Disable	Enable CardBus-to- CardBus Posting	Memory Prefetch Disable	
R/W:1	R/W:0	R/W:0	R/W:0	R/W:0	R/W:0	R/W:00	

Bits 1:0 — Memory Prefetch Disable

This bit disables memory prefetch when the CardBus card is bus master and is performing memory reads from host system memory.

Bit 1	Bit 0	Memory Prefetch
0	0	Prefetching is enabled.
1	1	Prefetching by CardBus master of PCI memory addresses is disabled.

NOTE: Bits 1:0 must be set to '00' or '11'; no other combinations are allowed.

Bit 2 — Enable CardBus-to-CardBus Posting

This bit controls CardBus-to-CardBus memory writes. It enables the posting of memory writes when the CardBus card is bus master and is performing memory writes to the other CardBus card in the CardBus controller. A safe policy is to set this bit only when there are cards operating in 32-bit CardBus mode in both sockets.

0	CardBus-to-CardBus posting is disabled. This bit must be disabled (cleared to '0') if there is an R2 card in the socket being written.
1	CardBus-to-CardBus posting is enabled. This bit should be enabled only if there are CardBus cards in both sockets.

Bit 3 — CardBus-to-PCI FIFO Disable

This bit disables the posting of memory writes to the PCI bus when the CardBus is bus master and is performing memory writes to PCI host memory.

0	CardBus-to-PCI posting is enabled.
1	CardBus-to-PCI posting is disabled.

Bit 4 — Reserved

This bit must be written to '0'.

Bit 5 — Disable I/O Posting

This bit disables posting of I/O writes when host PCI is bus master and is performing I/O writes to CardBus or R2 cards.

0	Posting of I/O writes is enabled.
1	Posting of I/O writes is disabled.

When this bit is set, I/O writes from the PCI bus to a PC Card do not post to the FIFO, but are issued directly to the PC Card.

Bit 6 — Disable Memory Posting

This bit disables posting of memory writes when host PCI is bus master and is performing memory writes to CardBus or R2 cards.

0	Posting of memory writes is enabled.
1	Posting of memory writes is disabled.

When this bit is set, memory writes from the PCI bus to a PC Card do not post to the FIFO, but are issued directly to the PC Card.

Bit 7 — FIFO Status / Flush FIFO

Value	I/O Read	I/O Write
0	FIFO not empty	No operation occurs (default at reset)
1	FIFO empty	Flush the FIFO

This bit controls FIFO operation and reports FIFO status. When this bit is set to '1' during write operations, all data in the FIFO is lost. During read operations, when this bit is '1', the FIFO is empty. During read operations when this bit is '0', the FIFO has valid data.

This bit is used to ensure that the FIFO is empty before changing any registers; register writes are retried if the FIFO is not empty.

FIFO contents are lost whenever any of the following occur:

- RST# pin (see [page 19](#)) is active.
- The card is removed.
- V_{CC} Power bit (see [page 95](#)) is programmed to '0'.
- The Flush FIFO bit is set to '1'.

11.3 Misc Control 2

<i>Register Name: Misc Control 2</i> <i>I/O Index: 1Eh</i> <i>Memory Offset: 81Eh</i>				<i>Register Per: chip</i> <i>Register Compatibility Type: ext.</i>			
<i>Bit 7</i>	<i>Bit 6</i>	<i>Bit 5</i>	<i>Bit 4</i>	<i>Bit 3</i>	<i>Bit 2</i>	<i>Bit 1</i>	<i>Bit 0</i>
RI_OUT/INTB is RI_OUT R/W:0	<i>Reserved</i>						
				R/W:0000000			

Bits 6:0 — Reserved

Bit 7 — RI_OUT/INTB is RI_OUT

0	Normal interrupt operation on the RI_OUT/INTB# pin.
1	The RI_OUT/INTB# pin is connected to the ring indicate pin on the system logic.

This bit determines the function of the RI_OUT/INTB# pin. When this bit is set to '1', RI_OUT/INTB# can be used to trigger restoration of system activity when a high-to-low change is detected on the BVD1/STSCHG#/RI# pin. Bit 5 of index 03h must be set to '1' for RI to work.

11.4 Chip Information

Register Name: Chip Information						Register Per: chip	
I/O Index: 1Fh						Register Compatibility Type: ext.	
Memory Offset: 81Fh							
Bit 7	Bit 6	Bit 5	Bit 4	Bit 3	Bit 2	Bit 1	Bit 0
Cirrus Logic Host-Adapter Identification		Dual/Single Socket	CL-PD6833 Revision Level			DMA Capable	
R:11		R:1	R:1111			R:1	

Bit 0 — DMA Capable

A '1' in this bit indicates that the CL-PD6833 is capable of DMA.

Bits 4:1 — CL-PD6833 Revision Level

This field is '1111', indicating to software that **Device Identification** registers described in [Section 11.9 on page 159](#) are to be accessed to determine the Revision ID. In Cirrus Logic PC Card controllers, if bits 4:1 of the register at Memory Offset 81Fh read back '0h', the chip information is contained in bits 3:0 of the register at Memory Offset 934h.

Bit 5 — Dual/Single Socket

0	Chip identified as a single-socket controller.
1	Chip identified as a dual-socket controller.

This bit specifies that the CL-PD6833 supports two sockets.

Bits 7:6 — Cirrus Logic Host-Adapter Identification

00	Second read after I/O write to this register.
11	First read after I/O write to this register.

This field identifies a Cirrus Logic host-adapter device. After chip reset or when doing an I/O write to this register, the first read of this register returns a '11'. On the next read, this field is '00'. This pattern of toggling data on subsequent reads can be used by software to determine presence of a Cirrus Logic host adapter in a system or to determine the occurrence of a device reset.

11.5 ATA Control

<i>Register Name: ATA Control</i> <i>I/O Index: 26h</i> <i>Memory Offset: 826h</i>						<i>Register Per: socket</i> <i>Register Compatibility Type: ext.</i>	
Bit 7	Bit 6	Bit 5	Bit 4	Bit 3	Bit 2	Bit 1	Bit 0
A25/CSEL	A24/M/S*	A23/VU	A22	A21	Scratchpad Bit	Speaker is LED Input	ATA Mode — PME_CXT
R/W:0	R/W:0	R/W:0	R/W:0	R/W:0	R/W:0	R/W:0	R/W:0

Bit 0 — ATA Mode — PME_CXT

0	Normal operation.
1	Configures the socket interface to handle ATA-type disk drives.

This bit reconfigures the particular socket as an ATA drive interface. Refer to [Table 14-1 on page 179](#) for PC Card socket pin definitions in ATA mode. This bit is part of the PME_CXT (PME Context), a set of register bits that do not get reset or initialized if PME Enable is true when the CL-PD6833 changes power states from D3 to D0 through a software PCI Bus Segment reset.

Bit 1 — Speaker is LED Input

0	Normal operation.
1	The PC Card SPKR# pin is used to drive the LED-OUT* pin.

This bit changes the function of the BVD2/SPKR#/LED# pin (see [page 19](#)) from digital speaker input to disk status LED input. When in I/O Card Interface mode or ATA mode, setting this bit to '1' reconfigures the BVD2/SPKR#/LED# input pin to serve as a LED# input from the socket. The level of the input then appears as an open-drain output on the LED1* or LED2* pin corresponding to the socket.

Bit 2 — Scratchpad Bit

Bit 3 — A21

In ATA mode, the value in this bit is applied to the ATA A21 pin and is vendor-specific. Certain ATA drive vendor-specific performance enhancements beyond the PCMCIA 2.1 standard can be controlled through use of this bit. This bit has no hardware control function when not in ATA mode.

Bit 4 — A22

In ATA mode, the value in this bit is applied to the ATA A22 pin and is vendor-specific. Certain ATA drive vendor-specific performance enhancements beyond the PCMCIA 2.1 standard can be controlled through use of this bit. This bit has no hardware control function when not in ATA mode.

Bit 5 — A23/VU

In ATA mode, the value in this bit is applied to the ATA A23 pin and is vendor-specific. Certain ATA drive vendor-specific performance enhancements beyond the PCMCIA 2.1 standard can be controlled through use of this bit. This bit has no hardware control function when not in ATA mode.

Bit 6 — A24/M/S*

In ATA mode, the value in this bit is applied to the ATA A24 pin and is vendor-specific. Certain ATA drive vendor-specific performance enhancements beyond the PCMCIA 2.1 standard can be controlled through use of this bit. This bit has no hardware control function when not in ATA mode.

Bit 7 — A25/CSEL

In ATA mode, the value in this bit is applied to the ATA A25 pin and is vendor-specific. Certain ATA drive vendor-specific performance enhancements beyond the PCMCIA 2.1 standard can be controlled through use of this bit. This bit has no hardware control function when not in ATA mode.

11.6 Extended Index

Register Name: Extended Index						Register Per: socket	
I/O Index: 2Eh, 6Eh						Register Compatibility Type: ext.	
Bit 7	Bit 6	Bit 5	Bit 4	Bit 3	Bit 2	Bit 1	Bit 0
Extended Index							
R/W:00000000							

This register controls which of the following registers at index 2Fh can be accessed:

Table 11-2. Extended Index Registers

Register Name at Index 2Fh	Extended Index	Memory Offset
<i>Scratchpad</i>	00h	–
<i>Reserved</i>	01h	–
<i>Reserved</i>	02h	–
Extension Control 1	03h	903h
<i>Reserved</i>	04h	–
Gen Map 0 Upper Address	05h	840h
Gen Map 1 Upper Address	06h	841h
Gen Map 2 Upper Address	07h	842h
Gen Map 3 Upper Address	08h	843h
Gen Map 4 Upper Address	09h	844h
<i>Reserved</i>	0Ah–17h	–
Pin Multiplex Control 0	–	914h
Pin Multiplex Control 1	–	915h
GPIO Output Control	18h	918h
GPIO Input Control	19h	919h
GPIO Output Data	1Ah	91Ah
GPIO Input Data	1Bh	91Bh
Prefetch Window Register	1Ch	91Ch
Gen Map 5 Upper Address	20h	845h
Gen Map 6 Upper Address	21h	846h
PCI Space Control	22h	922h
PC Card Space Control	23h	923h
Window Type Select	24h	924h

Table 11-2. Extended Index Registers (cont.)

Register Name at Index 2Fh	Extended Index	Memory Offset
Misc Control 3	25h	925h
SMB Power Control Address	26h	926h
Gen Map 0 Extra Control	27h	927h
Gen Map 1 Extra Control	28h	928h
Gen Map 2 Extra Control	29h	929h
Gen Map 3 Extra Control	2Ah	92Ah
Gen Map 4 Extra Control	2Bh	92Bh
Gen Map 5 Extra Control	2Ch	92Ch
Gen Map 6 Extra Control	2Dh	92Dh
Extension Card Status Change	2Eh	92Eh
Misc Control 4	2Fh	92Fh
Misc Control 5	30h	930h
Misc Control 6	31h	931h

For information on how to access these registers, see [Section 3.3 on page 42](#).

11.7 Extended Data

<i>Register Name:</i> Extended Data						<i>Register Per:</i> socket	
<i>I/O Index:</i> 2Fh, 6Fh						<i>Register Compatibility Type:</i> ext.	
<i>Bit 7</i>	<i>Bit 6</i>	<i>Bit 5</i>	<i>Bit 4</i>	<i>Bit 3</i>	<i>Bit 2</i>	<i>Bit 1</i>	<i>Bit 0</i>
Extended Data							

The data in this register allows the registers indicated by the **Extended Index** register to be read and written. The value of this register is the value of the register selected by the **Extended Index** register.

11.7.1 Extension Control 1

Register Name: Extension Control 1				Register Per: socket			
I/O Index: 2Fh Extended Index: 03h				Register Compatibility Type: ext.			
Memory Offset: 903h							
Bit 7	Bit 6	Bit 5	Bit 4	Bit 3	Bit 2	Bit 1	Bit 0
DREQ Enable		Pull-Up Control	Reserved		LED Activity Enable	Reserved	V _{CC} Power Lock
R/W:00		R/W:0	R/W:0	R/W:0	R/W:0	R/W:0	R/W:0

Bit 0 — V_{CC} Power Lock

0	The V _{CC} Power bit (bit 4 of Power Control register) is not locked.
1	The V _{CC} Power bit (bit 4 of Power Control register) cannot be changed by software.

This bit can be used to prevent card drivers from overriding the Socket Services' task of controlling power to the card, thus preventing situations where cards are powered incorrectly.

Bit 1 — Reserved
Bit 2 — LED Activity Enable

0	LED activity disabled.
1	LED activity enabled.

This bit allows the LED_OUT* and LED1* or LED2* pin corresponding to the socket to reflect any activity in the card. Whenever PC Card cycles are in process to or from a card in the respective sockets, LED1* or LED2* pin is active low.

Bits 4:3 — Reserved
Bit 5 — Pull-Up Control

0	Pull-ups on VS2, VS1, CD2, and CD1 are in use.
1	Pull-ups on VS2, VS1, CD2, and CD1 are turned off.

This bit turns off the pull-ups on VS2, VS1, CD2, and CD1. Turning off these pull-ups can be used in addition to Suspend mode to even further reduce power when cards are inserted, but no card accessibility is required. Even though power may or may not still be applied, all pull-ups and their associated inputs are disabled.

Note that insertion or removal of a card cannot be determined when this bit is set to '1'. Also, when a card is already in the socket, a card detect interrupt is generated when this bit is changed from '0' to '1'.

Bits 7:6 — DREQ Enable

These bits are used to identify which PC Card 16 pin is used for DREQ, and enable the DMA operation of the socket. At reset these bits are reset and this disables the DREQ line. When either or both of these bits are set, the DREQ pin is selected by the following table.

Bit 7	Bit 6	Pin Used
0	0	DREQ Disabled
0	1	INPACK#
1	0	WP/IOIS16
1	1	BVD2/SPKR#

11.7.2 Gen Map 0–6 Upper Address (Memory)

<i>Register Name:</i> Gen Map 0–6 Upper Address (Memory)						<i>Register Per:</i> socket	
<i>I/O Index:</i> 2Fh <i>Extended Index:</i> 05h–09h, 20h, 21h						<i>Register Compatibility Type:</i> ext.	
<i>Memory Offset:</i> 840h, 841h, 842h, 843h, 844h, 845h, 846h							
<i>Bit 7</i>	<i>Bit 6</i>	<i>Bit 5</i>	<i>Bit 4</i>	<i>Bit 3</i>	<i>Bit 2</i>	<i>Bit 1</i>	<i>Bit 0</i>
Upper Address							
R/W:00000000							

These bits are used in comparing PCI Address bits 31:24 for each memory window (0–6). These bits are used in conjunction with the **Window Type Select**, **Gen Map 0–6 Start Address**, and **Gen 0–6 End Address** registers.

If the **Window Type Select** bit corresponding to windows 0–4 is reset, that window is a memory window and this register specifies that window's upper address.

If the **Window Type Select** bit for a window is set and the corresponding bit in the **PCI Space Control** register is reset, then that window is a memory window on the PCI side. This register sets the upper address for that memory window.

If none of the above conditions is true, then this register is ignored.

11.7.3 Pin Multiplex Control 0 Register — PME_CXT

Register Name: Pin Multiplex Control 0 Register — PME_CXT I/O Index: 2Fh Extended Index: 14h Memory Offset: 914h (for function 0 only)						Register Per: chip Register Compatibility Type: ext.	
Bit 7	Bit 6	Bit 5	Bit 4	Bit 3	Bit 2	Bit 1	Bit 0
LED_OUT*/HW_SUSP*/PME#/GPIO4		SPKR_OUT*/GPIO3		SIN#/ISDAT/LED2*/GPIO2		INTA#/LED1*/GPIO1	
Select 1	Select 0	Select 1	Select 0	Select 1	Select 0	Select 1	Select 0
R/W:0	R/W:0	R/W:0	R/W:0	R/W:0	R/W:0	R/W:0	R/W:0

NOTE: PME_CXT (PME Context) is a set of register bits that do not get reset or initialized if PME Enable is true when the CL-PD6833 changes power states from D3 to D0 through a software PCI Bus Segment reset.

Bits 1:0 — INTA#/LED1*/GPIO1 Select 1:0

These bits select the function of pin 203.

Bit 1	Bit 0	Pin Function
0	0	INTA# or LED1* ^a
0	1	GPIO1
1	0	Do not program this value.
1	1	Do not program this value.

^a The socket A LED indicator, active-low OD, or LED_OUT* if configured for one LED.

Bits 3:2 — SIN#/ISDAT/LED2*/GPIO2 Select 1:0

These bits select the function of pin 206.

Bit 3	Bit 2	Pin Function
0	0	SIN#, ISDAT, or LED2* with control of pin characteristics per the CL-PD6833 bits ^a
0	1	GPIO2
1	0	Do not program this value.
1	1	Do not program this value.

^a The socket B LED indicator, active-low OD, or LED_OUT* if configured for one LED (dual socket is '0').

LED1* and LED2* features are only available in PCI/Way interrupt signalling mode.

Bits 5:4 — SPKR_OUT*/GPIO3 Select 1:0

These bits select the function of pin 128.

Bit 5	Bit 4	Pin Function
0	0	SPKR_OUT* with control of pin characteristics per the CL-PD6833.
0	1	GPIO3
1	0	Do not program this value.
1	1	Do not program this value.

Bits 7:6 — LED_OUT*/HW_SUSP*/PME#/GPIO4 Select 1:0

These bits select the function of pin 133.

Bit 7	Bit 6	Pin Function
0	0	LED_OUT* or HW_SUSP* with control of pin characteristics per the CL-PD6833
0	1	GPIO4
1	0	PME# as defined by the PCI specification (PCI power management add-on specification)
1	1	Do not program this value.

11.7.4 Pin Multiplex Control 1 Register — PME_CXT

<i>Register Name: Pin Multiplex Control 1 Register — PME_CXT</i> <i>I/O Index: 2Fh Extended Index: 15h</i> <i>Memory Offset: 915h (for function 1 only)</i>						<i>Register Per: chip</i> <i>Register Compatibility Type: ext.</i>	
<i>Bit 7</i>	<i>Bit 6</i>	<i>Bit 5</i>	<i>Bit 4</i>	<i>Bit 3</i>	<i>Bit 2</i>	<i>Bit 1</i>	<i>Bit 0</i>
<i>Reserved</i>						INTB#/ RI_OUT*/ PME# Select 1 R/W:0	INTB#/ RI_OUT*/ PME# Select 0 R/W:0
R/W:000000							

NOTE: PME_CXT (PME Context) is a set of register bits that do not get reset or initialized if PME Enable is true when the CL-PD6833 changes power states from D3 to D0 through a software PCI Bus Segment reset.

Bits 1:0 — INTB#/RI_OUT*/ PME# Select 1:0

These bits select the function of pin 204.

Bit 1	Bit 0	Pin Function
0	0	INTB# or RI_OUT*, using existing CL-PD6832 select bits
0	1	Do not program this value.
1	0	PME# as defined by PCI specification (PCI power management add-on specification)
1	1	Do not program this value.

Bits 7:2 — Reserved

11.7.5 GPIO Output Control

Register Name: GPIO Output Control				Register Per: chip			
I/O Index: 2Fh Extended Index: 18h				Register Compatibility Type: ext.			
Memory Offset: 918h							
Bit 7	Bit 6	Bit 5	Bit 4	Bit 3	Bit 2	Bit 1	Bit 0
Reserved				GPIO4 Output Control	GPIO3 Output Control	GPIO2 Output Control	GPIO1 Output Control
R/W:0	R/W:0	R/W:0	R/W:0	R/W:0	R/W:0	R/W:0	R/W:0

Bits 3:0 — GPIO[4:1] Output Control

When these bits are '0', the corresponding GPIO pin is put into the high-impedance state. Setting these bits causes the corresponding GPIO Output Data bit to be driven onto the corresponding GPIO pin. If the corresponding GPIO Input Control bit is low, the output drives both active high and active low. If the corresponding GPIO Input Control bit is high, the output is open-drain and drives low only.

Bits 7:4 — Reserved

11.7.6 GPIO Input Control

Register Name: GPIO Input Control				Register Per: chip			
I/O Index: 2Fh Extended Index: 19h				Register Compatibility Type: ext.			
Memory Offset: 919h							
Bit 7	Bit 6	Bit 5	Bit 4	Bit 3	Bit 2	Bit 1	Bit 0
GPIO4 Pull-up Enable	GPIO3 Pull-up Enable	GPIO2 Pull-up Enable	GPIO1 Pull-up Enable	GPIO4 Input Control	GPIO3 Input Control	GPIO2 Input Control	GPIO1 Input Control
R/W:0	R/W:0	R/W:0	R/W:0	R/W:0	R/W:0	R/W:0	R/W:0

Bits 3:0 — GPIO[4:1] Input Control

When these bits are set to '0', the corresponding inputs are disabled and read back '1's. This is used to prevent floating inputs from drawing excessive power. When these bits are set, the data read from the **GPIO Input Data** register reflects the value on the corresponding pin. If enabled, a floating input can cause excessive power consumption, and can cause the other inputs to operate incorrectly. If the corresponding GPIO Output Control bit is set, the pin is an output, regardless of the state of the GPIO Input Control bit.

Bits 7:4 — GPIO[4:1] Pull-up Enable

0	GPIO pin tristate or open-collector per register 918h and 919h.
1	GPIO pin pull-up resistor to '+5V' pin's supply, except when outputting '0'.

11.7.7 GPIO Output Data

<i>Register Name: GPIO Output Data</i> <i>I/O Index: 2Fh Extended Index: 1Ah</i> <i>Memory Offset: 91Ah</i>				Register Per: chip Register Compatibility Type: ext.			
Bit 7	Bit 6	Bit 5	Bit 4	Bit 3	Bit 2	Bit 1	Bit 0
Reserved				GPIO4 Output Data	GPIO3 Output Data	GPIO2 Output Data	GPIO1 Output Data
R/W:0				R/W:0	R/W:0	R/W:0	R/W:0

Bits 3:0 — GPIO[4:1] Output Data

When in the output mode, data written to this register is driven onto the corresponding GPIO pin. This register reads back what was last written, regardless of the state of the GPIO pins.

Bits 7:4 — Reserved

11.7.8 GPIO Input Data

<i>Register Name: GPIO Input Data</i> <i>I/O Index: 2Fh Extended Index: 1Bh</i> <i>Memory Offset: 91Bh</i>				Register Per: chip Register Compatibility Type: ext.			
Bit 7	Bit 6	Bit 5	Bit 4	Bit 3	Bit 2	Bit 1	Bit 0
Reserved				GPIO4 Input Data	GPIO3 Input Data	GPIO2 Input Data	GPIO1 Input Data
R/W:0				R:1	R:1	R:1	R:1

Bits 3:0 — GPIO[4:1] Input Data

If the corresponding GPIO Output Control and GPIO Input Control bits are both low, this address reads back a '1'. In any other case, this address reads the actual state of the GPIO pins whether in input or output mode. In the output mode, the data read from a pin can be compared to the corresponding data bit in the **GPIO Output Data** register to verify that there is not a problem with that output.

Bits 7:4 — Reserved

11.8 Prefetch Window Register

Configuration Register Name: Prefetch Window Register						Register Per: Socket		
I/O Index: 2Fh Extended Index 1Ch						Register Compatibility Type: ext.		
Offset: 91Ch								
Byte 3 (high)	Bit 31	Bit 30	Bit 29	Bit 28	Bit 27	Bit 26	Bit 25	Bit 24
	R/W:00000000							
Byte 2 (low)	Bit 23	Bit 22	Bit 21	Bit 20	Bit 19	Bit 18	Bit 17	Bit 16
	R/W:00000000							
Byte 1 (high)	Bit 15	Bit 14	Bit 13	Bit 12	Bit 11	Bit 10	Bit 9	Bit 8
	R/W:00000000							
Byte 0 (low)	Bit 7	Bit 6	Bit 5	Bit 4	Bit 3	Bit 2	Bit 1	Bit 0
	R/W:00000000							

This register is read-only in the current version of the CL-PD6833.

11.8.1 PCI Space Control

Register Name: PCI Space Control						Register Per: socket	
I/O Index: 2Fh Extended Index: 22h						Register Compatibility Type: ext	
Memory Offset: 922h							
Bit 7	Bit 6	Bit 5	Bit 4	Bit 3	Bit 2	Bit 1	Bit 0
Gen Map 6 PCI Type	Gen Map 5 PCI Type	<i>Reserved</i>	Gen Map 4 PCI Type	Gen Map 3 PCI Type	Gen Map 2 PCI Type	Gen Map 1 PCI Type	Gen Map 0 PCI Type
R/W:1	R/W:1	R/W:0	R/W:0	R/W:0	R/W:0	R/W:0	R/W:0

Bits 7:6, 4:0 — Gen Map [6:0] PCI Type

0	General Map registers configured for PCI memory operation.
1	General Map registers configured for PCI I/O operation.

If the corresponding bit in the **Window Type Select** register is set and the PCI Space Control bit is reset, then the programmed general map window responds to PCI *memory* operations. If the PCI Space Control bit is set, then the programmed general map window responds to PCI *I/O* operations. If the corresponding bit in the **Window Type Select** register is reset, this bit is ignored.

Bit 5 — Reserved

11.8.2 PC Card Space Control

<i>Register Name: PC Card Space Control</i> <i>I/O Index: 2Fh Extended Index: 23h</i> <i>Memory Offset: 923h</i>						<i>Register Per: socket</i> <i>Register Compatibility Type: ext</i>	
Bit 7	Bit 6	Bit 5	Bit 4	Bit 3	Bit 2	Bit 1	Bit 0
Gen Map 6 PC Card Type R/W:1	Gen Map 5 PC Card Type R/W:1	<i>Reserved</i> R/W:0	Gen Map 4 PC Card Type R/W:0	Gen Map 3 PC Card Type R/W:0	Gen Map 2 PC Card Type R/W:0	Gen Map 1 PC Card Type R/W:0	Gen Map 0 PC Card Type R/W:0

Bits 7:6, 4:0 — Gen Map [6:0] PC Card Type

0	General Map configured for PC Card Memory offset and commands.
1	General Map configured for PC Card I/O offset and commands.

If the corresponding bit in the **Window Type Select** register is set, and the PC Card Space Control bit is reset, then accesses through this window are *memory* commands to the PC Card. If the corresponding bit in the **Window Type Select** register is set and the PC Card Space Control bit is set, then accesses through this window are *I/O* commands to the PC Card.

If the corresponding bit in the **Window Type Select** register is reset, this bit is ignored.

Bit 5 — Reserved

11.8.3 Window Type Select

<i>Register Name: Window Type Select</i> <i>I/O Index: 2Fh Extended Index: 24h</i> <i>Memory Offset: 924h</i>						<i>Register Per: socket</i> <i>Register Compatibility Type: ext</i>	
Bit 7	Bit 6	Bit 5	Bit 4	Bit 3	Bit 2	Bit 1	Bit 0
Gen Map 6 Type R/W:0	Gen Map 5 Type R/W:0	<i>Reserved</i> R/W:0	Gen Map 4 Type R/W:0	Gen Map 3 Type R/W:0	Gen Map 2 Type R/W:0	Gen Map 1 Type R/W:0	Gen Map 0 Type R/W:0

Bits 7:6, 4:0 — Gen Map [6:0] Type

0	General Map registers configured for default operation.
1	General Map registers configured for programmable operation.

When these bits are set, the corresponding general windows are programmable with the **PCI Space Control** and **PC Card Space Control** registers. The controls for the Window Data Size, Timer Select, and Auto Data Size bits are programmed in the **Gen Map Extra Control** registers. When these bits are reset, the corresponding **General Map** registers revert to their default configuration. The controls for the Window Data Size, Timer Select, and Auto Data Size bits comes from the **I/O Window Control**, **Memory Map Start Address High**, and **Memory Map End Address High** registers.

Bit 5 — Reserved

11.8.4 Misc Control 3

Register Name: Misc Control 3						Register Per: chip	
I/O Index: 2Fh Extended Index: 25h						Register Compatibility Type: ext.	
Memory Offset: 925h							
Bit 7	Bit 6	Bit 5	Bit 4	Bit 3	Bit 2	Bit 1	Bit 0
Multimedia ARM	Reserved		Hardware Suspend Enable	Reserved	Socket Power-Control Interface Signalling Mode	System Interrupt Signalling Mode	
R/W:0	R/W:0	R/W:0 ^a	R/W:0	R/W: Power-on Reset ^b	R/W:0 ^c	R/W:00 ^d	

- ^a During power-on reset or hardware reset, bit 5 should be written to '0'.
- ^b Bit 3 is '0' if the last PCI_RST was during power-up and '1' if the last PCI_RST was a bus segment reset with power-on.
- ^c During power-on reset or hardware reset, bit 2 is loaded with value of the SLATCH/SMBCLK pin (130).
- ^d During power-on reset or hardware reset, bits 0 and 1 are filled from information provided on LED_OUT*/HW_SUSPEND# (133) and SPKR_OUT* (128) from [Table 11-3](#).

NOTE: Bits 3:0 are part of the PME_CXT (PME Context), a set of bits that do not get reset or initialized if PME Enable is true when the CL-PD6833 changes power states from D3 to D0 through a software PCI Bus Segment reset.

Table 11-3. Interrupt Signalling Power-on Settings

Settings	Misc Control 3 Bit 1	Misc Control 3 Bit 0	IRQ15	SIN#
PCI	1	1	Open	Pull-up
PCI/Way	1	0	Pull-down	Pull-down
PC/PCI	0	0	Pull-down	Pull-up
External-Hardware	0	1	Open	Pull-down

Bits 3:0 are configuration switches loaded during a power-on reset or hardware reset. The configuration values determine the type of serial interrupt protocol and the type of serial socket power control to be used. The configuration values are to be preset using pull-down resistors or a pull-up resistor. These bits can also be loaded through a register write. Bits 3:0 are connected to the pads as follows:

Bits 1:0 — System Interrupt Signalling Mode

Bit 1	Bit 0	Interrupt Signalling Mode
0	0	PC/PCI Interrupt Signalling mode. Requires systems supporting SIC (serial interrupt controller).
0	1	External-Hardware Interrupt Signalling mode.
1	0	PCI/Way serial format.
1	1	PCI Interrupt Signalling mode.

The CL-PD6833 supports four interrupt signalling modes: PCI Interrupt Signalling mode, PC/PCI Interrupt Signalling mode, External-Hardware Interrupt Signalling mode, and the PCI/Way serial format.

When configured for External-Hardware Interrupt Signalling, pins 205 and 206 are used as the ISLD and ISDAT signals to the external CL-PD6701 that provides eight parallel IRQ lines, pin 203 is INTA#, and pin 204 is INTB#/RI_OUT*. Refer to the application note “*Interrupt Signalling Modes for the CL-PD6730 and CL-PD6832*” (AN-PD8).

When configured for the PCI/Way Interrupt Signalling mode, pin 205 works as the IRQSER bidirectional interrupt line. Pin 203 works as INTA# and pin 204 works as INTB#/RI_OUT*. Pin 206 is not used. This is the only mode in which pin 203 works as an LED indicator for socket 0 and pin 205 works as a LED indicator for socket 1. Refer to the **Misc. Control 5** register at Extended index 30h (memory offset 930h).

Bit 2 — Socket Power-Control Interface Signalling Mode

0	TI's TPS2206 Serial Signalling mode (uses 3 pins, supports two sockets) or CL-PD6701 Serial Signalling mode (currently uses TI's TPS2206 serial protocol)
1	System Management Bus Signalling mode (uses 2 pins, supports two sockets)

When this bit is '0', the TI's TPS2206 serial interface protocol is enabled. This interface uses three pins: SCLK, SDATA, and SLATCH. SCLK is the reference clock to the CL-PD6833. The power control data is sent to TI's TPS2206 over the SDATA pin and latch signal over the SLATCH pin.

When this bit is '1', the Intel SMBus protocol is supported. This interface uses two pins, namely SMBDATA and SMBCLK. The reference clock of 32 kHz is fed through the SCLK pin and is required during suspend (both hardware and software). The power control data is sent serially over SMBDATA (bidirectional) and clock over SMBCLK. This interface is used by MAX1601 dual-socket power control chip (serial version) when bit 5 of this register is '0'. When bit 5 is '1', the new SMBus protocol is used and status read back is available.

Bit 3 — Reserved

This bit is '0' if the last PCI_RST was during power-up, and '1' if the last PCI_RST was a bus segment reset with power-on.

Bit 4 — Hardware Suspend Enable

0	Normal operation
1	Device goes into Hardware Suspend if the SUSPEND# pin (133) is low.

Bits 6:5 — Reserved

Bit 7 — Multimedia ARM

0	Multimedia ARM disabled. ZV Port pins (connected to VGA ZV Port) are high-impedance.
1	Multimedia ARM enabled. ZV Port pins (connected to VGA ZV Port) are enabled.

No multimedia operation can occur without setting this bit to '1'; the bit provides an overriding control mechanism. The Multimedia Arm bit ensures that multimedia operation is not inadvertently set by software or point enablers.

This bit also controls the output drivers of the ZV Port. See the Multimedia Enable bit 0 (in [Section 11.1 on page 132](#)). This bit must be set to '0' with bit 0 of index 16h.

11.8.5 SMBus Socket Power Control Address — PME_CXT

Register Name: SMBus Socket Power Control Address — PME_CXT I/O Index: 2Fh Extended Index: 26h Memory Offset: 926h						Register Per: chip Register Compatibility Type: ext.	
Bit 7	Bit 6	Bit 5	Bit 4	Bit 3	Bit 2	Bit 1	Bit 0
A6	A5	A4	A3	A2	A1	Reserved	
R/W:1	R/W:0	R/W:1	R/W:0	R/W:0	R/W:0	R/W:00	

NOTE: PME_CXT (PME Context) is a set of register bits that do not get reset or initialized if PME Enable is true when the CL-PD6833 changes power states from D3 to D0 through a software PCI Bus Segment reset.

Bits 1:0 — Reserved

Bits 7:2 — SMBus Socket Power Control Address A[6:1]

This register contains the most-significant six bits of the SMBus (system management bus) slave address for the socket power-control device. The SMBus specification for the slave address for a PC Card socket power control device is 101000XX. This register resets to '101000' for bits 7:2, and the socket power control device can be hard configured to this address to eliminate additional software setup. The CL-PD6833 supports the MAX1601, which is a dual-socket power control chip employing the SMBus protocol (see also the register [Misc Control 3 on page151](#)).

11.8.6 Gen Map 0–6 Extra Control (I/O)

<i>Register Name: Gen Map 0–6 Extra Control (I/O)</i> <i>I/O Index: 2Fh Extended Index: 27h–2Dh</i> <i>Memory Offset: 927h–92Dh</i>				Register Per: socket Register Compatibility Type: ext.			
Bit 7	Bit 6	Bit 5	Bit 4	Bit 3	Bit 2	Bit 1	Bit 0
Reserved				Extra Timing Register Select	Reserved	Extra Auto-Size I/O Window	Extra I/O Window Size
R:0000				R/W:0	R/W:0	R/W:0	R/W:0

Bit 0 — Extra I/O Window Size

0	8-bit data path to Gen Map I/O Window.
1	16-bit data path to Gen Map I/O Window.

When bit 1 of this register is '0', this bit determines the width of the data path for Gen Map I/O Window accesses to the card. When bit 1 is '1', this bit is ignored.

Bit 1 — Extra Auto-Size I/O Window

0	Gen Map I/O Window Size (see bit 0 of this register) determines the data path for Gen Map I/O Window accesses.
1	The data path to Gen Map I/O Window is determined by the IOIS16# level returned by the card.

This bit determines the width of the data path for Gen Map I/O Window accesses to the card. Note that when this bit is '1', the IOIS16# signal determines the width of the data path to the card.

Bit 2 — Reserved
Bit 3 — Extra Timing Register Select

0	Accesses made with timing specified in Timer Set 0 registers.
1	Accesses made with timing specified in Timer Set 1 registers.

This bit determines the access timing specification for Gen Map I/O Window.

Bits 7:4 — Reserved

11.8.7 Gen Map 0–6 Extra Control (Memory)

When the Window Type Select register bit corresponding to a general map register is set (and that window is configured in PC Card space control as Memory), this register is used to program the Memory behavior to the PC Card socket. When the **Window Type Select** register bit is reset, this register is ignored. When the **Window Type Select** register bit is set and the **PC Card Space Control** register bit is set to '0' (indicating memory operation), this register is configured as follows.

<i>Register Name: Gen Map 0–6 Extra Control (Memory)</i> <i>I/O Index: 2Fh Extended Index: 27h–2Dh</i> <i>Memory Offset: 927h–92Dh</i>						Register Per: socket Register Compatibility Type: ext.	
Bit 7	Bit 6	Bit 5	Bit 4	Bit 3	Bit 2	Bit 1	Bit 0
Reserved				Extra Card Timer Select		Reserved	Extra Window Data Size
R:0000				R/W:00		R/W:0	R/W:0

Bit 0 — Extra Window Data Size

0	8-bit data path to PC Card.
1	16-bit data path to PC Card.

Bit 1 — Reserved

Bits 3:2 — Extra Card Timer Select

Bit 3	Bit 2	Timer Set Select
0	0	Selects Timer Set 0
0	1	Selects Timer Set 1
1	0	Selects Timer Set 1
1	1	Selects Timer Set 1

This field selects the timer set. Timer Set 0 and 1 reset to values compatible with standard PCI and three-wait-state cycles.

Bits 7:4 — Reserved

11.8.8 Extension Card Status Change

Register Name: Extension Card Status Change				Register Per: socket			
I/O Index: 2Fh Extended Index: 2Eh				Register Compatibility Type: ext.			
Memory Offset: 92Eh							
Bit 7	Bit 6	Bit 5	Bit 4	Bit 3	Bit 2	Bit 1	Bit 0
Reserved				(Latched) Card Detect Change	(Latched) Ready Change	(Latched) Battery Warning Change	(Latched) Battery Dead or Status Change
R:0	R:0	R:0	R:0	R/C:0	R/C:0	R/C:0	R/C:0

This register indicates the source of a management interrupt generated by the CL-PD6833.

NOTE: The corresponding bit in the **Management Interrupt Configuration** register must be set to '1' to enable each specific status bit change detection. This register can only be cleared after accessing register 804h, and writing a '1' to the corresponding bit in register 92Eh.

Bit 0 — Battery Dead Or Status Change

0	A transition (from high to low in Memory Card Interface mode or either high to low or low to high in I/O Card Interface mode) on the BVD1/STSCHG#/RI# pin has not occurred since this register was last read.
1	A transition on the BVD1/STSCHG#/RI# pin has occurred.

In Memory Card Interface mode, this bit is set to '1' when the BVD1/STSCHG#/RI# pin (see [page 20](#)) changes from high to low, indicating a battery dead condition. In I/O Card Interface mode, this bit is set to '1' when the BVD1/STSCHG#/RI# pin changes from either high to low or low to high. In I/O Card Interface mode, the function of this bit is not affected by bit 7 of the **Interrupt and General Control** register. This bit is reset to a '0' if the **Card Status** register is first cleared and then a '1' is written to this bit.

Bit 1 — Battery Warning Change

0	A transition (from high to low) on the BVD2/SPKR#/LED# pin has not occurred since this register was last read.
1	A transition on the BVD2/SPKR#/LED# pin has occurred.

In Memory Card Interface mode, this bit is set to '1' when the BVD2/SPKR#/LED# pin changes from high to low, indicating a battery warning. This bit is not valid in I/O Card Interface mode. This bit is reset to a '0' if the **Card Status** register is first cleared and then a '1' is written to this bit.

Bit 2 — Ready Change

0	A transition on the RDY/IREQ# pin has not occurred since this register was last read.
1	A transition on the RDY/IREQ# pin has occurred.

This bit is '1' when a change has occurred on the RDY/IREQ# pin. This bit is reset to a '0' if the **Card Status** register is first cleared and then a '1' is written to this bit.

Bit 3 — Card Detect Change

0	A transition on neither the CD1# nor the CD2# pin has occurred since this register was last read.
1	A transition on either the CD1# or the CD2# pin or both has occurred.

This bit is set to '1' when a change has occurred on the CD1# or CD2# pin. This bit is reset to a '0' if the **Card Status** register is first cleared and then a '1' is written to this bit.

Bits 7:4 — Reserved

11.8.9 Misc Control 4

<i>Register Name: Misc Control 4</i> <i>I/O Index: 2Fh Extended Index: 2Fh</i> <i>Memory Offset: 92Fh</i>					<i>Register Per: socket</i> <i>Register Compatibility Type: ext.</i>		
<i>Bit 7</i>	<i>Bit 6</i>	<i>Bit 5</i>	<i>Bit 4</i>	<i>Bit 3</i>	<i>Bit 2</i>	<i>Bit 1</i>	<i>Bit 0</i>
<i>Reserved</i>					Slot Active	Socket Clock Divide Control	
R:0	R:0	R:0	R:0	R:0	R:0	R/W:00	

Bits 1:0 — Socket Clock Divide Control

These bits control the clock rate to the sockets and are a binary divide of the PCI input clock.

Bit 2 — Slot Active

This bit is reset to '0' by RST# and by any read of this register. When the PC Card is accessed for write or read, this bit is set. This bit can be used to monitor the traffic flow of a card. By reading this bit during a periodic interrupt, a profile of the card activity can be established for power management.

Bits 7:3 — Reserved

11.8.10 Misc Control 5

<i>Register Name: Misc Control 5</i> <i>I/O Index: 2Fh Extended Index: 30h</i> <i>Memory Offset: 930h</i>							<i>Register Per: socket</i> <i>Register Compatibility Type: ext.</i>
Bit 7	Bit 6	Bit 5	Bit 4	Bit 3	Bit 2	Bit 1	Bit 0
Reserved							Dual LED Enable
R:0000000							R/W:0

Bit 0 — Dual LED Enable

When this bit is set to '1', pin 203 works as an active-low LED output for Socket 0 activity. Pin 206 works as an active-low LED output for Socket 1 activity. This feature is available only in the PCI/Way Interrupt Signalling mode. Refer to the **Misc Control 3** register on [page 151](#).

Bits 7:1 — Reserved
11.8.11 Misc Control 6

<i>Register Name: Misc Control 6</i> <i>I/O Index: 2Fh Extended Index: 31h</i> <i>Memory Offset: 931h</i>							<i>Register Per: socket</i> <i>Register Compatibility Type: ext.</i>
Bit 7	Bit 6	Bit 5	Bit 4	Bit 3	Bit 2	Bit 1	Bit 0
Y-V Socket	X-V Socket	3.3-V Socket	5-V Socket	Reserved			
W:0	W:0	W:1	W:1	R:0000			

Bits 3:0 — Reserved
Bit 4 — 5-V Socket

This bit sets the 5-V Socket bit in the **Present State** register. Writing '1' sets this bit in the **Present State** register, and writing '0' clears bit in the **Present State** register.

Bit 5 — 3.3-V Socket

This bit sets the 3.3-V Socket bit in the **Present State** register. Writing '1' sets this bit in the **Present State** register, and writing '0' clears bit in the **Present State** register.

Bit 6 — X-V Socket

This bit sets the X-V Socket bit in the **Present State** register. Writing '1' sets this bit in the **Present State** register, and writing '0' clears bit in the **Present State** register.

Bit 7 — Y-V Socket

This bit sets the Y-V Socket bit in the **Present State** register. Writing '1' sets this bit in the **Present State** register, and writing '0' clears bit in the **Present State** register.

11.9 Device Identification and Implementation Scheme

There are four-byte-wide registers with read-only device information, and four-byte-wide read/write registers that contain specific system implementation information.

Determining This Register Exists

If bits 4:1 of the **Chip Information** register (memory offset 81Fh) read back '0h', the chip information is contained in bits 3:0 of the **Mask Revision** register (memory offset 934h).

11.9.1 Mask Revision Byte

Register Name: Mask Revision Byte				Register Per: chip			
I/O Index: 34h				Register Compatibility Type: ext.			
Memory Offset: 934h							
Bit 7	Bit 6	Bit 5	Bit 4	Bit 3	Bit 2	Bit 1	Bit 0
RFU				Mask Revision			
R:0	R:0	R:0	R:0	R:0	R:0	R:0	R:0

Bits 3:0 — Mask Revision

These bits indicate the mask revision of the device. The binary value is interpreted as in the following table:

Bits 3:0	Mask Revision
0h	A
1h	B
2h	C
3h	D
4h	E
5h	F
6h	G
7h	H
8h	J
9h	K
Ah	L
Bh	M
Ch	N
Dh	P
Eh	Q
Fh	R

Bits 7:4 — RFU (reserved for future use)

11.9.2 Product ID Byte

<i>Register Name: Product ID Byte</i>				<i>Register Per: chip</i>			
<i>I/O Index: 35h</i>				<i>Register Compatibility Type: ext.</i>			
<i>Memory Offset: 935h</i>							
<i>Bit 15</i>	<i>Bit 14</i>	<i>Bit 13</i>	<i>Bit 12</i>	<i>Bit 11</i>	<i>Bit 10</i>	<i>Bit 9</i>	<i>Bit 8</i>
Family Code				Product Code			
R:0	R:1	R:0	R:0	R:0	R:0	R:0	R:1

Bits 11:8 — Product Code

These bits indicate the product code of the device within its family.

Product Codes — CL-PD6833 family

0h	CL-PD6833 PCI/CardBus controller, dual isolated sockets, 208-pin MQFP or LQFP.
2h–Fh	Reserved for future use for the CL-PD683X devices.

Bits 15:12 — Family Code

A value of '04h' indicates the CL-PD683X family.

11.9.3 Device Capability Byte A

Register Name: Device Capability Byte A						Register Per: chip	
I/O Index: 36h						Register Compatibility Type: ext.	
Memory Offset: 936h							
Bit 23	Bit 22	Bit 21	Bit 20	Bit 19	Bit 18	Bit 17	Bit 16
Per-Socket LED	RFU	GPSTB Capable	RFU	Slave DMA	IDE Interface	# Sockets 1	# Sockets 0
R:1	R:0	R:0	R:0	R:1	R:0	R:0	R:1

Bits 17:16 — # Sockets [1:0] (Number of Sockets Supportable by Device)

This bit field indicates how many sockets a device is capable of supporting, expressed as the highest socket index number supportable, for example '00' indicates only socket 0 is supportable, meaning a single socket device, and '11' indicates sockets 3 through 0 are supportable, indicating a four-socket capable device.

Bit 18 — IDE Interface

A value of '0' indicates that the CL-PD6833 does not support driving an external IDE drive.

Bit 19 — Slave DMA

A '1' at this bit indicates that the CL-PD6833 can act as a DMA slave. The Slave DMA Wired bit (bit 2 of the **Device Implementation Byte A** register; see [page 163](#)) indicates whether a system is wired to allow this feature to be used.

Bit 20 — RFU (reserved for future use)

Bit 21 — GPSTB Capable

A value of '0' in this field indicates that the CL-PD6833 does not support general-purpose strobe.

Bit 22 — RFU (reserved for future use)

Bit 23 — Per-Socket LED

If this bit is set to '1', the device is capable of supporting independent LEDs on each socket.

If this bit is set to '1', it is intended that Socket Services would check bits 16 and 17 of the Device Implementation Byte C register (see [page 165](#)) to determine if per-socket LEDs are supported in the system implementation. The description of bits 16 and 17 explains the software implications if per-socket LED support is to be enabled.

11.9.4 Device Capability Byte B

<i>Register Name: Device Capability Byte B</i> <i>I/O Index: 37h</i> <i>Memory Offset: 937h</i>						<i>Register Per: chip</i> <i>Register Compatibility Type: ext.</i>	
<i>Bit 31</i>	<i>Bit 30</i>	<i>Bit 29</i>	<i>Bit 28</i>	<i>Bit 27</i>	<i>Bit 26</i>	<i>Bit 25</i>	<i>Bit 24</i>
Extended Definitions		RFU (ZV)		RFU (CB)	CLKRUN# Support	LOCK# Support	CardBus Capable
R:0		R:0		R:0	R:1	R:1	R:1

Bit 24 — CardBus Capable

A '1' in this bit indicates that the CL-PD6833 is capable of supporting PC Card 32 (CardBus) cards.

Bit 25 — LOCK# Support

A '1' indicates that the CL-PD6833 is capable of supporting operations involving the LOCK# signal.

Note that bit 25 of the Device Implementation Byte D register must be referenced to determine whether LOCK# is a supported signal in the system implementation.

Bit 26 — CLKRUN# Support

A '1' indicates that the CL-PD6833 is capable of supporting PCI Mobile Specification CLKRUN# signalling for control of system clock turn on/turn off.

Note that the least-significant bit of the Device Implementation Byte D register must be referenced to determine whether this feature is supported in the system implementation.

Bits 30:27 — RFU (reserved for future use)

Bit 31 — Extended Definitions

A '0' indicates that there is no extended definition.

11.9.5 Device Implementation Byte A

Register Name: Device Implementation Byte A						Register Per: chip	
I/O Index: 38h						Register Compatibility Type: ext.	
Memory Offset: 938h							
Bit 7	Bit 6	Bit 5	Bit 4	Bit 3	Bit 2	Bit 1	Bit 0
RI_OUT Wired	Hardware Suspend Wired	GPSTB B Wired	GPSTB A Wired	VS1/VS2 Wired	Slave DMA Wired	Sockets Present 1	Sockets Present 0
R/W:0	R/W:0	R/W:0	R/W:0	R/W:1	R/W:0	R/W:0	R/W:1

All bits of this byte are read/write. Device reset defaults are specific to each device. A BIOS write to this byte before bringing of socket services sets these bits to reflect which of these features are supported in the system implementation.

Bit 0 — Sockets Present 0

Bit 1 — Sockets Present 1

Bits 1:0 indicate the socket features supported in the system implementation.

Bit 2 — Slave DMA Wired

This bit indicates whether the system is wired to allow the slave DMA feature to be used.

Bit 3 — VS1/VS2 Wired

When this bit is '1', the system is wired to use the VS1/VS2 pin. When this bit is '0' the system is not wired and is not capable of using the VS1/VS2 pin.

Bits 5:4 — GPSTB [B:A] Wired

Bits 5:4 indicate the general-purpose strobe features supported in the system implementation.

Bit 6 — Hardware Suspend Wired

A '1' indicates that a pin on the device designated as a hardware control of suspend for deep power saving has been connected to system circuitry designed for power management.

Bit 7 — RI_OUT Wired

A '1' indicates that a pin on the device designated as 'RI_OUT' has been connected to ring indicate circuitry. Socket services must set the **Misc. Control 2** register (I/O index 1E) bit 7 to a '1', thereby enabling this alternate pin definition as it has been wired.

A value of '1' implies that the RI_OUT*/INTB# pin is not connected to the PCI bus INTB# line, but is instead connected to an SMI type system function designed to wake up a system on modem ring.

11.9.6 Device Implementation Byte B

Register Name: Device Implementation Byte B						Register Per: chip	
I/O Index: 39h						Register Compatibility Type: ext.	
Memory Offset: 939h							
Bit 15	Bit 14	Bit 13	Bit 12	Bit 11	Bit 10	Bit 9	Bit 8
RFU	RF Rated Sockets	VPP_ VCC 1A	VPP 12 V Available	X-V Capable	Y-V Capable	5.0-V V _{CC} Capable	3.3-V V _{CC} Capable
R/W:0	R/W:1	R/W:0	R/W:1	R/W:0	R/W:0	R/W:1	R/W:1

Bit 8 — 3.3-V V_{CC} Capable

A value of '1' indicates that 3.3-V voltage source is available in this system. A value of '0' indicates that 3.3-V voltage source is not available in this system.

Bit 9 — 5.0-V V_{CC} Capable

A value of '1' indicates that 5.0-V voltage source is available in this system. A value of '0' indicates that 5.0-V voltage source is not available in this system.

Bit 10 — Y-V Capable

A value of '1' indicates that Y.Y-V voltage source is available in this system. A value of '0' indicates that Y.Y-V voltage source is not available in this system.

Bit 11 — X-V Capable

A value of '1' indicates that X.X-V voltage source is available in this system. A value of '0' indicates that X.X-V voltage source is not available in this system.

Bit 12 — VPP 12 V Available

A value of '1' indicates that a VPP of 12 V is supported in this system. A value of '0' indicates that a VPP of 12 V is not supported in this system.

Bit 13 — VPP_ VCC 1A

A value of '1' indicates that the socket can deliver 1 A at $V_{PP} = V_{CC}$.

Bit 14 — RF Rated Sockets

A value of '1' indicates that the sockets in this system are designed to handle cards that operate at radio frequencies like cellular fax/modem and pagers. A value of '0' indicates that the sockets in this system are not designed to handle cards that operate at radio frequencies like cellular fax/modem and pagers.

Bit 15 — RFU (reserved for future use)

11.9.7 Device Implementation Byte C

<i>Register Name: Device Implementation Byte C</i>						<i>Register Per: chip</i>	
<i>I/O Index: 3Ah</i>						<i>Register Compatibility Type: ext.</i>	
<i>Memory Offset: 93Ah</i>							
<i>Bit 23</i>	<i>Bit 22</i>	<i>Bit 21</i>	<i>Bit 20</i>	<i>Bit 19</i>	<i>Bit 18</i>	<i>Bit 17</i>	<i>Bit 16</i>
RFU	RFU (ZV)		ZV Port B Wired	ZV Port A Wired	SPKR Wired	Per-Socket LED	LED Wired
R/W:0	R/W:0		R/W:1	R/W:1	R/W:1	R/W:0	R/W:0

Bit 16 — LED Wired

A value of '1' indicates that a single activity socket LED is available for both sockets. A value of '0' indicates that a single activity socket LED is not available for both sockets.

Bit 17 — Per-Socket LED

A value of '1' indicates that an activity socket LED is available on each socket and is controlled through extended index 930h. A value of '0' indicates an activity socket LED is not available on each socket and is not controlled through extended index 930h.

Bit 18 — SPKR Wired

A value of '1' indicates that a speaker is connected to the sockets. A value of '0' indicates that a speaker is not connected to the sockets.

Bit 19 — ZV Port A Wired

A value of '1' indicates that Socket A is wired for ZV operation. A value of '0' indicates that Socket A is not wired for ZV operation.

Bit 20 — ZV Port B Wired

A value of '1' indicates that Socket B is wired for ZV operation. A value of '0' indicates that Socket B is not wired for ZV operation.

Bits 23:21 — RFU (reserved for future use)

11.9.8 Device Implementation Byte D

<i>Register Name: Device Implementation Byte D</i>						<i>Register Per: chip</i>	
<i>I/O Index: 3Bh</i>						<i>Register Compatibility Type: ext.</i>	
<i>Memory Offset: 93Bh</i>							
<i>Bit 31</i>	<i>Bit 30</i>	<i>Bit 29</i>	<i>Bit 28</i>	<i>Bit 27</i>	<i>Bit 26</i>	<i>Bit 25</i>	<i>Bit 24</i>
RFU	Clk Option Wired			RFU		LOCK# Wired	CLKRUN# Wired
R/W:0	R/W:0			R/W:0		R/W:1	R/W:1

Bit 24 — CLKRUN# Wired

A value of '1' indicates that the system supports CLKRUN# protocol. A value of '0' indicates that the system does not support CLKRUN# protocol.

Bit 25 — LOCK# Wired

A value of '1' indicates that the system supports a LOCK#. A value of '0' indicates that the system does not support a LOCK#.

Bits 29:26 — RFU (reserved for future use)
Bit 30 — Clk Option Wired

A value of '1' indicates that an external clock is available to the CL-PD6833. A value of '0' indicates that an external clock is not available to the CL-PD6833.

Bit 31 — RFU (reserved for future use)

12. TIMING REGISTERS

Table 12-1. Timing Registers Quick Reference

Register Name	I/O Index	Memory Offset	Page Number
Setup Timing 0–1	3Ah, 3Dh	83Ah, 83Dh	167
Command Timing 0–1	3Bh, 3Eh	83Bh, 83Eh	168
Recovery Timing 0–1	3Ch, 3Fh	83Ch, 83Fh	169

The following information about the timing registers is important:

- All timing registers take effect immediately and should only be changed when the FIFO is empty (see the **FIFO Control** register on [page 134](#)).
- Selection of **Timer Set 0** or **Timer Set 1** register sets is controlled by **I/O Window Control** bits 3 and 7.

12.1 Setup Timing 0–1

Register Name: Setup Timing 0–1				Register Per: socket			
I/O Index: 3Ah, 3Dh				Register Compatibility Type: 365			
Memory Offset: 83Ah, 83Dh							
Bit 7	Bit 6	Bit 5	Bit 4	Bit 3	Bit 2	Bit 1	Bit 0
Reserved		Setup Multiplier Value					
R:00		R/W:000000/000011					

There are two separate **Setup Timing** registers, each with identical fields. These registers are located at the following indexes:

Index (Socket A)	Setup Timing
3Ah	Setup Timing 0
3Dh	Setup Timing 1

The **Setup Timing** register for each timer set controls how long a PC Card cycle's command (that is, OE#, WE#, IORD#, IOWR#; see [Table 2-2 on page 15](#)) setup time is, in terms of the number of internal clock cycles.

The overall command setup timing length S is programmed by selecting a value (bits 5:0) to produce the overall command setup timing length according to the following formula:

$$S = N_{val} + 1 \quad \text{Equation 12-1}$$

The value of S , representing the number of clock cycles for command setup, is then multiplied by the clock period to determine the actual command setup time (see [Section 15.3.3](#) for further discussion).

Bits 5:0 — Setup Multiplier Value

This field indicates an integer value N_{val} from 0 to 63 to control the length of setup time before a command becomes active.

Bits 7:6 — Reserved

12.2 Command Timing 0–1

Register Name: Command Timing 0–1				Register Per: socket			
I/O Index: 3Bh, 3Eh				Register Compatibility Type: 365			
Memory Offset: 83Bh, 83Eh							
Bit 7	Bit 6	Bit 5	Bit 4	Bit 3	Bit 2	Bit 1	Bit 0
Reserved		Command Multiplier Value					
R:00		R/W:000111/010001					

There are two separate **Command Timing** registers, each with identical fields. These registers are located at the following indexes:

I/O Index	Memory Offset	Command Timing (Socket A)
3Bh	83Bh	Command Timing 0
3Eh	83Eh	Command Timing 1

The **Command Timing** register for each timer set controls how long a PC Card cycle's command (that is, OE#, WE#, IORD#, IOWR#; see [Table 2-2 on page 15](#)) active time is, in terms of the number of internal clock cycles.

The overall command timing length C is programmed by selecting a multiplier value (bits 5:0) to produce the overall command timing length according to the following formula:

$$C = N_{val} + 1 \quad \text{Equation 12-2}$$

The value of C , representing the number of clock cycles for a command, is then multiplied by the clock period to determine the actual command active time (see [Section 15.3.3](#) for further discussion).

Bits 5:0 — Command Multiplier Value

This field indicates an integer value N_{val} from 0 to 63; it controls the length that a command is active.

Bits 7:6 — Reserved

12.3 Recovery Timing 0–1

Register Name: Recovery Timing 0–1				Register Per: socket			
I/O Index: 3Ch, 3Fh				Register Compatibility Type: 365			
Memory Offset: 83Ch, 83Fh							
Bit 7	Bit 6	Bit 5	Bit 4	Bit 3	Bit 2	Bit 1	Bit 0
Reserved		Recovery Multiplier Value					
R:00		R/W:000100/000100					

There are two separate **Recovery Timing** registers, each with identical fields. These registers are located at the following indexes:

I/O Index	Memory Offset	Recovery Timing (Socket A)
3Ch	83Ch	Recovery Timing 0
3Fh	83Fh	Recovery Timing 1

The **Recovery Timing** register for each timer set controls how long a PC Card cycle's command (that is, OE#, WE#, IORD#, IOWR#; see [Table 2-2 on page 15](#)) recovery time is, in terms of the number of internal clock cycles.

The overall command recovery timing length R is programmed by selecting a multiplier value (bits 5:0) to produce the overall command recovery timing length according to the following formula:

$$R = N_{val} + 1 \quad \text{Equation 12-3}$$

The value of R , representing the number of clock cycles for command recovery, is then multiplied by the clock period to determine the actual command recovery time (see [Section 15.3.3](#) for further discussion).

Bits 5:0 — Recovery Multiplier Value

This field indicates an integer value N_{val} from 0 to 63; it controls the length of recovery time after a command is active.

Bits 7:6 — Reserved

Notes

13. DMA OPERATION REGISTERS

Table 13-1. DMA Operation Registers Quick Reference

Register Name	DMA Base Address Offset	Page Number
Low Address	0h	172
Mid Low Address	1h	172
Mid High Address	2h	173
High Address	3h	173
Low Count	4h	174
Mid Count	5h	174
High Count	6h	174
DMA Command and Status	8h	175
Request Register	9h	176
Mode Register	Bh	177
Master Clear	Dh	178
Mask Register	Fh	178

This chapter discusses the **DMA** registers used to make PCI/Way DMA operate. All registers in this chapter are **I/O** registers offset from the **DMA Slave Configuration** register. Bits 31:4 of this register make up the DMA base address used for all of these registers. The registers in this chapter are derived from the Intel 8237 register set.

13.1 Low Address

<i>Register Name: Low Address</i>				<i>Register Per: socket</i>			
<i>I/O Index: 0h</i>				<i>Register Compatibility Type: DMA</i>			
<i>Bit 7</i>	<i>Bit 6</i>	<i>Bit 5</i>	<i>Bit 4</i>	<i>Bit 3</i>	<i>Bit 2</i>	<i>Bit 1</i>	<i>Bit 0</i>
Low Address 8 bit 7:0 16 bit 8:1 R/W:00000000							

This register is used to form part of the address for DMA transfers. This register corresponds to the **Base and Current Address** register of the Intel 8237 for write operations. For read operations this register contains the current address.

Bits 7:0 — Low Address

When bits 2:1 of the **DMA Slave Configuration** register indicate that an 8-bit transfer is to occur, this register contains the starting address bits 7:0. If bits 2:1 of the **DMA Slave Configuration** register indicate that a 16-bit transfer is to occur, then this register contains starting address bits 8:1 and address 0 is always '0' at the PC Card.

13.2 Mid Low Address

<i>Register Name: Mid Low Address</i>				<i>Register Per: socket</i>			
<i>I/O Index: 1h</i>				<i>Register Compatibility Type: DMA</i>			
<i>Bit 7</i>	<i>Bit 6</i>	<i>Bit 5</i>	<i>Bit 4</i>	<i>Bit 3</i>	<i>Bit 2</i>	<i>Bit 1</i>	<i>Bit 0</i>
Mid Low Address 8 bit 15:8 16 bit 16:9 R/W:00000000							

This register is used to form part of the address for DMA transfers.

Bits 7:0 — Mid Low Address

This register corresponds to the **Base and Current Address** register of the Intel 8237 for write operations. For read operations this register contains the current address. When bits 2:1 of the **DMA Slave Configuration** register indicate that an 8-bit transfer is to occur, this register contains the starting address bits 15:8. If bits 2:1 of the **DMA Slave Configuration** register indicate that a 16-bit transfer is to occur, then this register contains the starting address bits 16:9.

13.3 Mid High Address

Register Name: Mid High Address				Register Per: socket			
I/O Index: 2h				Register Compatibility Type: DMA			
Bit 7	Bit 6	Bit 5	Bit 4	Bit 3	Bit 2	Bit 1	Bit 0
Mid High Address							
8 bit 23:16							
16 bit 23:17							
R/W:00000000							

This register is used to form part of the address for DMA transfers.

Bits 7:0 — Mid High Address

This register corresponds to the **Base and Current Address** register of the Intel 8237 for write operations. For read operations this register contains the Current Address. When bits 2:1 of the **DMA Slave Configuration** register indicate that an 8-bit transfer is to occur, this register contains the starting address bits 23:16. If bits 2:1 of the **DMA Slave Configuration** register indicate that a 16-bit transfer is to occur, then this register contains low address bits 23:17, and bit 0 of this register is not used.

13.4 High Address

Register Name: High Address				Register Per: socket			
I/O Index: 3h				Register Compatibility Type: DMA			
Bit 7	Bit 6	Bit 5	Bit 4	Bit 3	Bit 2	Bit 1	Bit 0
High Address							
8 bit 31:24							
16 bit 31:24							
R/W:00000000							

This register is used to form part of the address for DMA transfers. This register is only employed to indicate the memory address of the DMA transfer when bit 3 of the **DMA Slave Configuration** is set to a '1'.

Bits 7:0 — High Address

This register corresponds to the **Base and Current Address** register of the Intel 8237 for write operations. For read operations this register contains the current address. This register contains the starting address bits 31:24. This register is enabled by bit 3 of the **DMA Slave Configuration** register. If bit 3 of the **DMA Slave Configuration** is reset, then address bits 31:24 are '00' during DMA transfers from the CL-PD6833 to memory.

13.5 Low Count

<i>Register Name: Low Count</i>				<i>Register Per: socket</i>			
<i>I/O Index: 4h</i>				<i>Register Compatibility Type: DMA</i>			
<i>Bit 7</i>	<i>Bit 6</i>	<i>Bit 5</i>	<i>Bit 4</i>	<i>Bit 3</i>	<i>Bit 2</i>	<i>Bit 1</i>	<i>Bit 0</i>
Low Count 7:0							
R/W:00000000							

This register is used to form part of the count for DMA transfers.

Bits 7:0 — Low Count

This register corresponds to the Base and Current Word Count of the Intel 8237 register set. DMA transfers are counted by transaction, not by byte, word, or doubleword. The count registers count down from the programmed value to zero and then one more. When written, this register is the total count of transactions plus one. When read, this register reflects the remaining transactions.

13.6 Mid Count

<i>Register Name: Mid Count</i>				<i>Register Per: socket</i>			
<i>I/O Index: 5h</i>				<i>Register Compatibility Type: DMA</i>			
<i>Bit 7</i>	<i>Bit 6</i>	<i>Bit 5</i>	<i>Bit 4</i>	<i>Bit 3</i>	<i>Bit 2</i>	<i>Bit 1</i>	<i>Bit 0</i>
Mid Count 15:8							
R/W:00000000							

This register is used to form part of the count for DMA transfers.

Bits 7:0 — Mid Count

13.7 High Count

<i>Register Name: High Count</i>				<i>Register Per: socket</i>			
<i>I/O Index: 6h</i>				<i>Register Compatibility Type: DMA</i>			
<i>Bit 7</i>	<i>Bit 6</i>	<i>Bit 5</i>	<i>Bit 4</i>	<i>Bit 3</i>	<i>Bit 2</i>	<i>Bit 1</i>	<i>Bit 0</i>
High Count 23:16							
R/W:00000000							

This register is used to form part of the Count for DMA transfers when bit 3 of the **DMA Slave Configuration** register is set. When that bit is not set, this register is not used.

Bits 7:0 — High Count

When enabled this register can be used to increase the total number of transfers above the original 64-Kbyte transfers of the original Intel 8237.

13.8 DMA Command and Status

<i>Register Name: DMA Command and Status</i>					<i>Register Per: socket</i>		
<i>I/O Index: 8h</i>					<i>Register Compatibility Type: DMA</i>		
<i>Bit 7</i>	<i>Bit 6</i>	<i>Bit 5</i>	<i>Bit 4</i>	<i>Bit 3</i>	<i>Bit 2</i>	<i>Bit 1</i>	<i>Bit 0</i>
DACK Sense	DREQ Sense	Extended Write Select	Rotating Priority	Compressed Timing	Controller Disable	Address Hold Enable	Mem-to-Mem Enable
R:0	R:0	R:0	R:0	R/W:0	R:0	R:0	R/W:0

Bit 0 — Mem-to-Mem Enable

Reads from this bit return terminal count.

Bit 1 — Address Hold Enable

Reads from this bit return terminal count.

Bit 2 — Controller Disable

This bit disables DMA transfers. Reads from this bit return terminal count.

Bit 3 — Compressed Timing

Reads from this bit return terminal count.

Bit 4 — Rotating Priority

Reads from this bit return the state of the PC Card DMA request line inverted.

Bit 5 — Extended Write Select

Reads from this bit return the state of the PC Card DMA request line inverted.

Bit 6 — DREQ Sense

Reads from this bit return the state of the PC Card DMA request line inverted.

Bit 7 — DACK Sense

Reads from this bit return the state of the PC Card DMA request line inverted.

13.9 Request Register

<i>Register Name:</i> Request Register					<i>Register Per:</i> socket		
<i>I/O Index:</i> 9h					<i>Register Compatibility Type:</i> DMA		
<i>Bit 7</i>	<i>Bit 6</i>	<i>Bit 5</i>	<i>Bit 4</i>	<i>Bit 3</i>	<i>Bit 2</i>	<i>Bit 1</i>	<i>Bit 0</i>
		Reserved			Set Request		Reserved
		R:00000			W:0		R:00

This register is similar to the request register of the Intel 8237. Reads from this register are undefined and only the set request bit has any meaning for this implementation.

Bits 1:0 — Reserved

Bit 2 — Set Request

If the transfer mode bits are set to do block transfers, this bit initiates transfers with no hardware request present on the PC Card interface.

Bits 7:3 — Reserved

13.10 Mode Register

Register Name: Mode Register				Register Per: socket			
I/O Index: Bh				Register Compatibility Type: DMA			
Bit 7	Bit 6	Bit 5	Bit 4	Bit 3	Bit 2	Bit 1	Bit 0
Request Mode		Address Decrement	Autoinitialize	Transfer Mode		Channel Number (Ignored)	
R/W:00		R/W:0	R/W:0	R/W:00		R/W:00	

This register emulates the mode register of the Intel 8237. Unlike the Intel 8237 mode register, this register is readable.

Bits 1:0 — Channel Number (Ignored)

Writes to these bits have no effect. These bits read back what was written to them.

Bits 3:2 — Transfer Mode

These two bits determine the transfer mode to be used.

Bit 3	Bit 2	Transfer Mode
0	0	Verify mode
0	1	DMA write
1	0	DMA read
1	1	Reserved

Bit 4 — Autoinitialize

This bit puts the DMA controller in auto-initialize mode. In this mode the current address and count registers are reloaded from the **Base** registers. This sets the DMA controller for a new transfer at the end of the current transfer.

Bit 5 — Address Decrement

If this bit is set the addresses generated proceed downward from the base address until the count is exhausted. If this bit is reset, the addresses generated increment until the end of transfer.

Bits 7:6 — Request Mode

These two bits determine the request mode to be used.

Bit 7	Bit 6	Request Mode
0	0	Demand mode
0	1	Single Transfer mode
1	0	Block mode select
1	1	Cascade mode (not implemented)

13.11 Master Clear

<i>Register Name: Master Clear</i>						<i>Register Per: socket</i>	
<i>I/O Index: Dh</i>						<i>Register Compatibility Type: DMA</i>	
<i>Bit 7</i>	<i>Bit 6</i>	<i>Bit 5</i>	<i>Bit 4</i>	<i>Bit 3</i>	<i>Bit 2</i>	<i>Bit 1</i>	<i>Bit 0</i>
Master Clear							
R/W:0							

Bits 7:0 — Master Clear

This register emulates the Master Clear register of the Intel 8237. Unlike the Intel 8237, there is no temporary register to read back, so read back is not supported. When this register is written, the DMA section of the CL-PD6833 assumes the same state as caused by PCI_RST. The **DMA Slave Configuration** register is unaffected by writes to this register.

13.12 Mask Register

<i>Register Name: Mask Register</i>						<i>Register Per: socket</i>	
<i>I/O Index: Fh</i>						<i>Register Compatibility Type: DMA</i>	
<i>Bit 7</i>	<i>Bit 6</i>	<i>Bit 5</i>	<i>Bit 4</i>	<i>Bit 3</i>	<i>Bit 2</i>	<i>Bit 1</i>	<i>Bit 0</i>
Reserved							Mask
R/W:0							R/W:0

This register emulates the Mask registers of the Intel 8237. Unlike the Intel 8237, there is only one channel represented here. Read back is supported.

Bit 0 — Mask

When this bit is '1', the DREQ from the PC Card is ignored. When this bit is '0', DMA requests are enabled. This bit is automatically set if the Autoinitialize bit is not set when a transfer completes.

Bits 7:1 — Reserved

14. ATA MODE OPERATION

The CL-PD6833 card interfaces can be dynamically configured to support a PC Card-compatible ATA disk interface (commonly known as 'IDE') instead of the standard PC Card interface. Disk drives that can be made mechanically-compatible with PC Card dimensions can thus operate through the socket using the ATA electrical interface.

Configuring a socket to support ATA operation changes the function of certain card socket signals to support the needs of the ATA disk interface. Table 14-1 lists each interface pin and its function when a CL-PD6833 card socket is operating in ATA mode. Refer to the Cirrus Logic application note *Configuring PCMCIA Sockets for ATA Drive Interface (AN-PD5)* for more information.

All register functions of the CL-PD6833 are available in ATA mode, including socket power control, interface signal disabling, and card window control. No memory operations are allowed in ATA mode.

NOTE: General Windows 5 and 6 must be used for proper ATA operation.

Table 14-1. ATA Pin Cross-Reference

PC Card Socket Pin Number	Function	
	PC Card Interface	ATA Interface
1	Ground	Ground
2	D3	D3
3	D4	D4
4	D5	D5
5	D6	D6
6	D7	D7
7	-CE1	-CS0
8	A10	n/c
9	-OE	-ATA (always low)
10	A11	n/c
11	A9	CS1*
12	A8	n/c
13	A13	n/c
14	A14	n/c
15	-WE	n/c
16	-IREQ	IREQ
17	VCC	VCC

Table 14-1. ATA Pin Cross-Reference (cont.)

PC Card Socket Pin Number	Function	
	PC Card Interface	ATA Interface
18	VPP1	n/c
19	A16	n/c
20	A15	n/c
21	A12	n/c
22	A7	n/c
23	A6	n/c
24	A5	n/c
25	A4	n/c
26	A3	n/c
27	A2	A2
28	A1	A1
29	A0	A0
30	D0	D0
31	D1	D1
32	D2	D2
33	-IOIS16	-IOCS16
34	Ground	Ground

Table 14-1. ATA Pin Cross-Reference (cont.)

PC Card Socket Pin Number	Function	
	PC Card Interface	ATA Interface
35	Ground	Ground
36	-CD1	-CD1
37	D11	D11
38	D12	D12
39	D13	D13
40	D14	D14
41	D15	D15
42	-CE2	-CS1
43	VS1	VS1
44	-IORD	-IORD
45	-IOWR	-IOWR
46	A17	n/c
47	A18	n/c
48	A19	n/c
49	A20	n/c
50	A21	n/c
51	VCC	VCC

Table 14-1. ATA Pin Cross-Reference (cont.)

PC Card Socket Pin Number	Function	
	PC Card Interface	ATA Interface
52	VPP2	n/c
53	A22	n/c
54	A23	VU
55	A24	-M/S
56	A25	CSEL
57	VS2	VS2
58	RESET	RESET*
59	-WAIT	IOCHRDY
60	-INPACK	DREQ
61	-REG	-DACK
62	-SPKR	-LED
63	-STSCHG	-PDIAG
64	D8	D8
65	D9	D9
66	D10	D10
67	-CD2	-CD2
68	Ground	Ground

15. ELECTRICAL SPECIFICATIONS

15.1 Absolute Maximum Ratings

Description	Absolute Maximum Rating ^a
Ambient temperature under bias	0°C to 70°C
Storage temperature	-65°C to 150°C
Voltage on any pin (with respect to ground)	-0.3 V to 0.3 V greater than the voltage of the +5V pin, respective to ground
Operating power dissipation	750 mW
Power dissipation during Suspend mode	10 mW
Power supply voltage	7 V ^a
Injection current (latch up)	25 mA ^a

^a Stresses above those listed may cause permanent damage to system components. These are stress ratings only; functional operation at these or any conditions above those indicated in the operational sections of this specification is not implied. Exposure to absolute maximum rating conditions for extended periods of time may affect system reliability.

15.2 DC Specifications

Table 15-1. General DC Specifications

Symbol	Parameter	MIN	MAX	Unit	Conditions
C _{IN}	Input capacitance		10.0	pF	
C _{OUT}	Output capacitance		10.0	pF	
I _{IL}	Input leakage	-10.0	10.0	μA	0 < V _{IN} < respective V _{CC} supply pin
I _{PU}	Internal pull-up current	-30	-400	μA	

Table 15-2. PC Card (PCMCIA) Bus Interface DC Specifications

Symbol	Parameter	MIN	MAX	Unit	Conditions
SOCKET_VCC _{5V}	Power supply voltage	4.5	5.5	V	Normal operation
SOCKET_VCC _{3V}		3.0	3.6	V	
V _{IH}	Input high voltage	2.0		V	V _{DD} core voltage = 3.0 V
V _{IL}	Input low voltage		0.8	V	V _{DD} core voltage = 3.6 V
V _{OH}	Output high voltage	2.4		V	At rated I _{OH} , respective SOCKET_VCC = 3.0 V
V _{OHC}	Output high voltage CMOS	SOCKET_VCC – 0.5		V	At rated I _{OHC} , respective SOCKET_VCC = 3.0 V
V _{OL}	Output low voltage		0.4	V	At rated I _{OL}
I _{OH}	Output high current	–2		mA	Respective SOCKET_VCC = 3.0 V, V _{OH} = 2.4 V
I _{OHC}	Output high current CMOS	–1		mA	Respective SOCKET_VCC = 3.0 V, V _{OHC} = SOCKET_VCC – 0.5 V
I _{OL}	Output low current	2		mA	Respective SOCKET_VCC = 3.0 V, V _{OL} = 0.4 V

Table 15-3. PCI Bus Interface DC Specifications

Symbol	Parameter	MIN	MAX	Unit	Conditions
PCI_VCC _{5V}	Power supply voltage	4.5	5.5	V	Normal operation
PCI_VCC _{3V}		3.0	3.6	V	
V _{IH} ^a	Input high voltage	2.0		V	V _{DD} core voltage = 3.0 V
V _{IL} ^a	Input low voltage		0.8	V	V _{DD} core voltage = 3.6 V
V _{OH}	Output high voltage	2.4		V	At rated I _{OH} , PCI_VCC = 3.0 V
V _{OHC}	Output high voltage CMOS	PCI_VCC – 0.5		V	At rated I _{OHC} , PCI_VCC = 3.0 V
V _{OL}	Output low voltage		0.5	V	At rated I _{OL}
I _{OH}	Output current high	–5		mA	PCI_VCC = 3.0 V, V _{OH} = 2.4 V
I _{OHC}	Output current high CMOS	–1		mA	PCI_VCC = 3.0 V, V _{OHC} = PCI_VCC – 0.5 V
I _{OL}	Output current low	16		mA	PCI_VCC = 3.0 V, V _{OL} = 0.5 V

^a When CORE_VDD is 3.3 V, input thresholds are TTL-compatible; when CORE_VDD is 5 V, input thresholds are CMOS-compatible.

Table 15-4. General I/O Pin DC Specifications for 2-, 4-, 8-, and 16-mA Class Outputs

Symbol	Parameter	MIN	MAX	Unit	Conditions
VCC _{5V}	Power supply voltage	4.5	5.5	V	Operation of interface in 5-V range
VCC _{3V}	Power supply voltage	3.0	3.6	V	Operation of interface in 3.3-V range
V _{IHC}	Input high voltage	0.7 V _{DD}		V	CORE_VDD = 3.0/4.5 V
V _{ILC}	Input low voltage		0.2 V _{DD}	V	CORE_VDD = 3.6/5.5 V
V _{OH}	Output high voltage	2.4		V	At rated I _{OH} , Interface V _{CC} = 3.0 V
I _{OHC}	Output high voltage CMOS	Interface VCC – 0.5		V	At rated I _{OL}
I _{OH}	Output current high, 2-mA-type driver	–2		mA	Interface V _{CC} = 3.0 V, V _{OH} = 2.4 V +5 V = 4.5 V
	Output current high, 4-mA-type driver	–3		mA	
	Output current high, 8-mA-type driver	–4		mA	
	Output current high, 16-mA-type driver	–5		mA	

Table 15-4. General I/O Pin DC Specifications for 2-, 4-, 8-, and 16-mA Class Outputs (cont.)

Symbol	Parameter	MIN	MAX	Unit	Conditions
I_{OL}	Output current low, 2-mA-type driver	2		mA	ISA_V _{CC} = 3.0 V, V _{OL} = 0.5 V +5 V = 4.5 V
	Output current low, 4-mA-type driver	4		mA	
	Output current low, 8-mA-type driver	8		mA	
	Output current low, 16-mA-type driver	16		mA	

Table 15-5. Operating Current Specifications (3.3 V)

Symbol	Parameter	MIN	TYP	MAX	Unit	Conditions
$I_{CC_{tot}(1)}$	Power supply current, operating	tbd	tbd	tbd	mA	CORE_VDD = 3.3 V; +5V, SOCKET_VCC, and PCI_VCC = 5.0 V; P _{DISS} = < 85 mW
$I_{CC_{tot}(2)}$	Power supply current, Suspend mode (Misc Control 2, bit 2 = '1')		tbd		μA	CORE_VDD = 3.3 V; +5V, SOCKET_VCC, and PCI_VCC = 5.0 V; P _{DISS} = < 2 mW
$I_{CC_{tot}(3)}$	Power supply current, RST# active, no clocks		tbd		μA	CORE_VDD = 3.3 V; +5V, SOCKET_VCC, and PCI_VCC = 5.0 V; P _{DISS} = < 1 mW

15.3 AC Timing Specifications

This section includes system timing requirements for the CL-PD6833. Unless otherwise specified, timings are provided in nanoseconds (ns), at TTL input levels, with the ambient temperature varying from 0°C to 70°C, and V_{CC} varying from 3.0 V to 3.6 V, or 4.5 V to 5.5 V DC. The PCI bus speed is 33 MHz, unless otherwise specified. Note the following conventions:

- A pound sign (#) at the end of a pin name indicates an active-low signal for the PCI bus.
- A dash (-) at the beginning of a pin name indicates an active-low signal for the PC Card (PCMCIA) bus.
- An asterisk (*) at the end of a pin name indicates an active-low signal that is a general interface for the CL-PD6833.

Additionally, the following statements are true for all timing information:

- All timings assume a load of 50 pF.
- TTL signals are measured at TTL threshold; CMOS signals are measured at CMOS threshold.

Table 15-6. Index of AC Timing Specifications

Title	Page Number
Table 15-7. FRAME#, AD[31:0], C/BE[3:0]#, and DEVSEL#	186
Table 15-8. TRDY# and STOP# Delay	188
Table 15-9. IDSEL Timing in a Configuration Cycle	189
Table 15-10. PAR Timing (PCI Bus)	190
Table 15-11. Pulse Mode Interrupt Timing	191
Table 15-12. Memory Read/Write Timing	193
Table 15-13. Word I/O Read/Write Timing	194
Table 15-14. PC Card (PCMCIA) Read/Write Timing when System is 8-Bit	196
Table 15-15. Normal Byte Read/Write Timing	197
Table 15-16. 16-Bit System to 8-Bit I/O Card (Odd Byte Timing)	198

15.3.1 PCI Bus Timing
Table 15-7. FRAME#, AD[31:0], C/BE[3:0]#, and DEVSEL#

Symbol	Parameter	PCI_VCC = 3.3 V		PCI_VCC = 5.0 V		Units
		MIN	MAX	MIN	MAX	
t ₁	FRAME# setup to PCI_CLK	7	–	7	–	ns
t ₂	AD[31:0] (address) setup to PCI_CLK	7	–	7	–	ns
t ₃	AD[31:0] (address) hold from PCI_CLK	0	–	0	–	ns
t ₄	AD[31:0] (data) setup to PCI_CLK	7	–	7	–	ns
t ₅	AD[31:0] (data) active to High-Z from PCI_CLK	0	28	0	28	ns
t ₆	C/BE[3:0]# (bus command) setup to PCI_CLK	7	–	7	–	ns
t ₇	C/BE[3:0]# (bus command) hold from PCI_CLK	0	–	0	–	ns
t ₈	C/BE[3:0]# (byte enable) setup to PCI_CLK	7	–	7	–	ns
t ₉	DEVSEL# delay from PCI_CLK	–	11	–	11	ns
t ₁₀	DEVSEL# high before High-Z	1	–	1	–	PCI_CLK

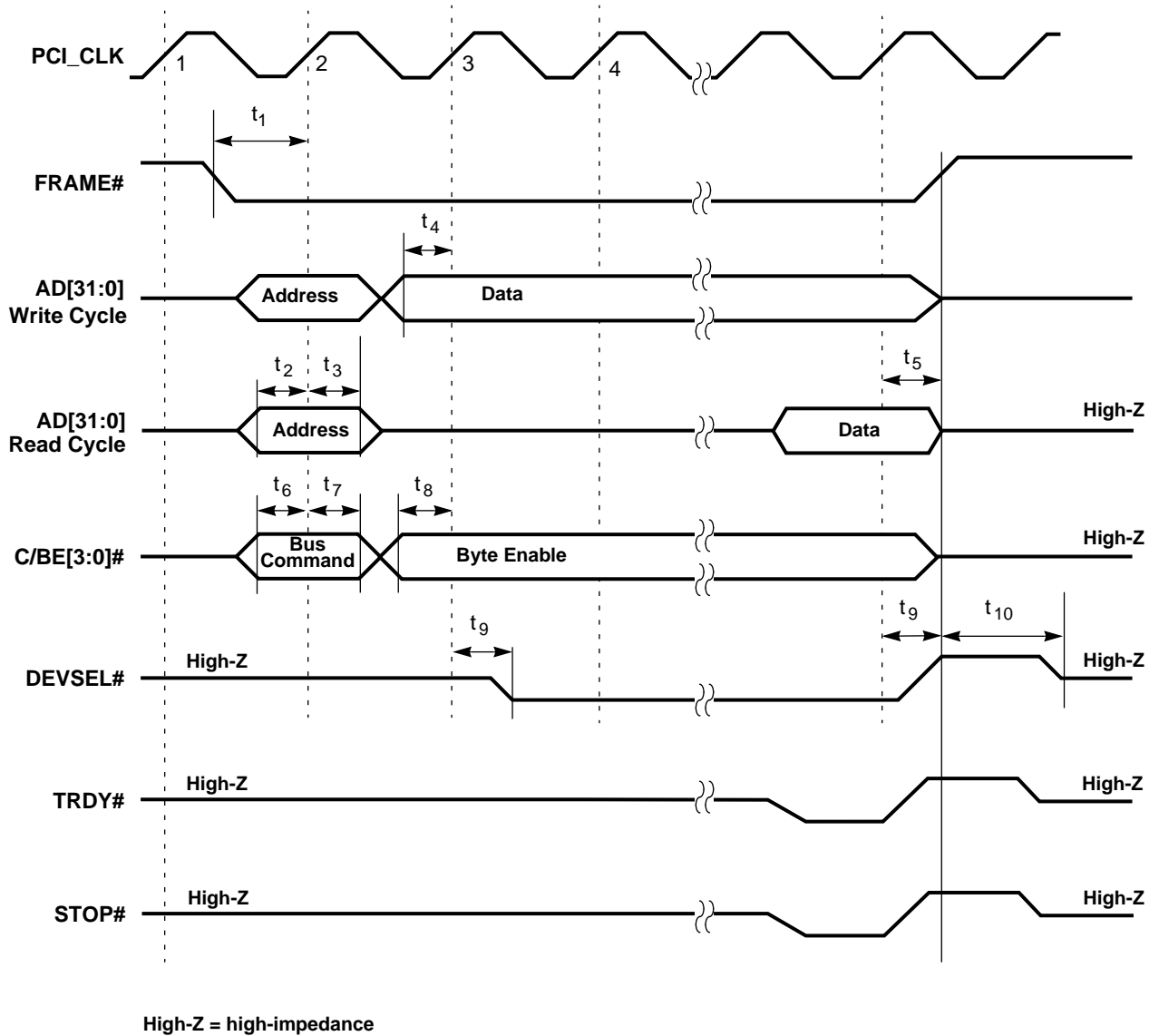


Figure 15-1. FRAME#, AD[31:0], C/BE[3:0]#, and DEVSEL# (PCI™ Bus)

Table 15-8. TRDY# and STOP# Delay

Symbol	Parameter	PCI_VCC = 3.3 V		PCI_VCC = 5.0 V		Units
		MIN	MAX	MIN	MAX	
t_1	TRDY# active delay from PCI_CLK	–	11	–	11	ns
t_2	TRDY# inactive delay from PCI_CLK	–	11	–	11	ns
t_3	TRDY# high before High-Z	1	–	1	–	PCI_CLK
t_4	STOP# active delay from PCI_CLK	–	11	–	11	ns
t_5	STOP# inactive delay from PCI_CLK	–	11	–	11	ns
t_6	STOP# high before High-Z	1	–	1	–	PCI_CLK

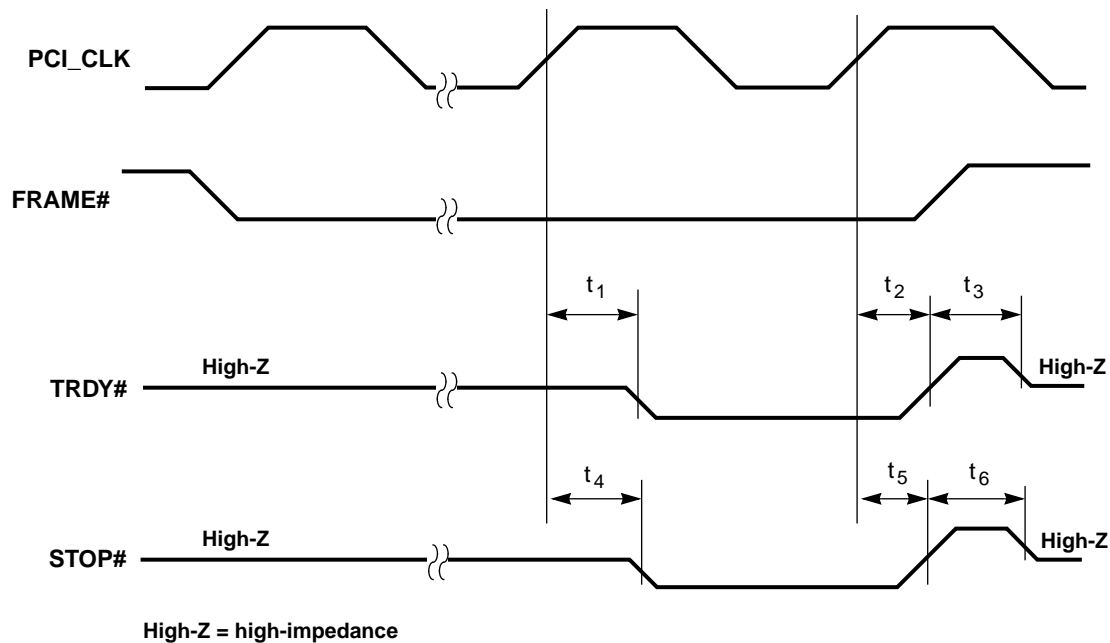

Figure 15-2. TRDY# and STOP# Delay (PCI™ Bus)

Table 15-9. IDSEL Timing in a Configuration Cycle

Symbol	Parameter	MIN	MAX	Units
t_1	IDSEL setup to PCI_CLK	7	–	ns
t_2	IDSEL hold from PCI_CLK	0	–	ns

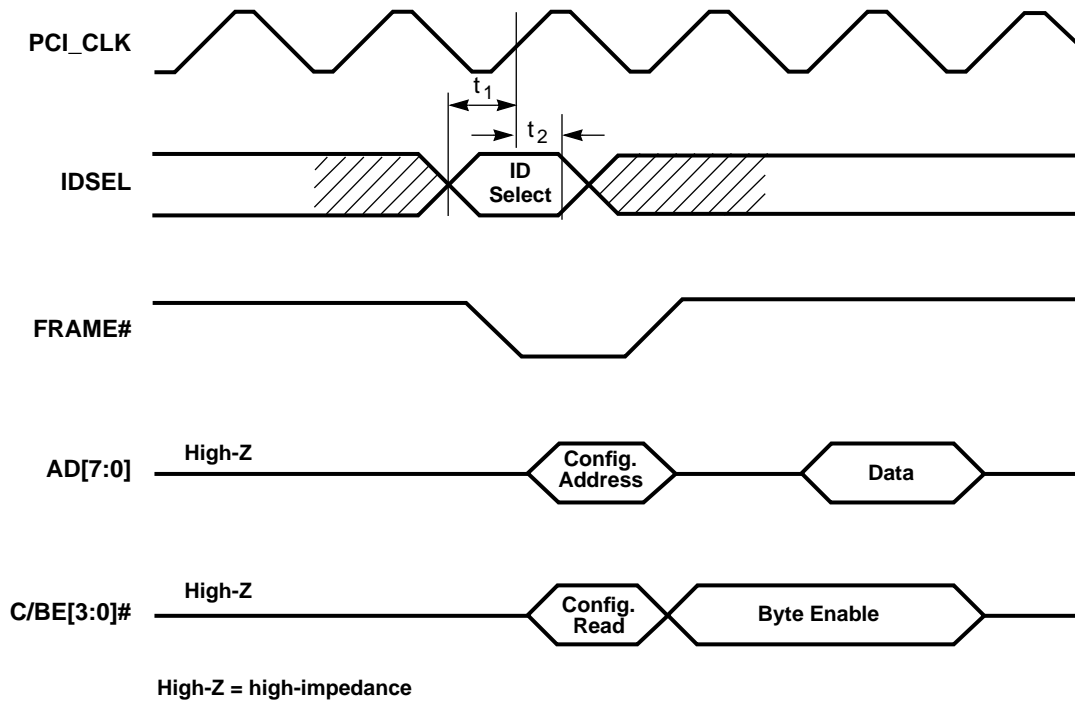
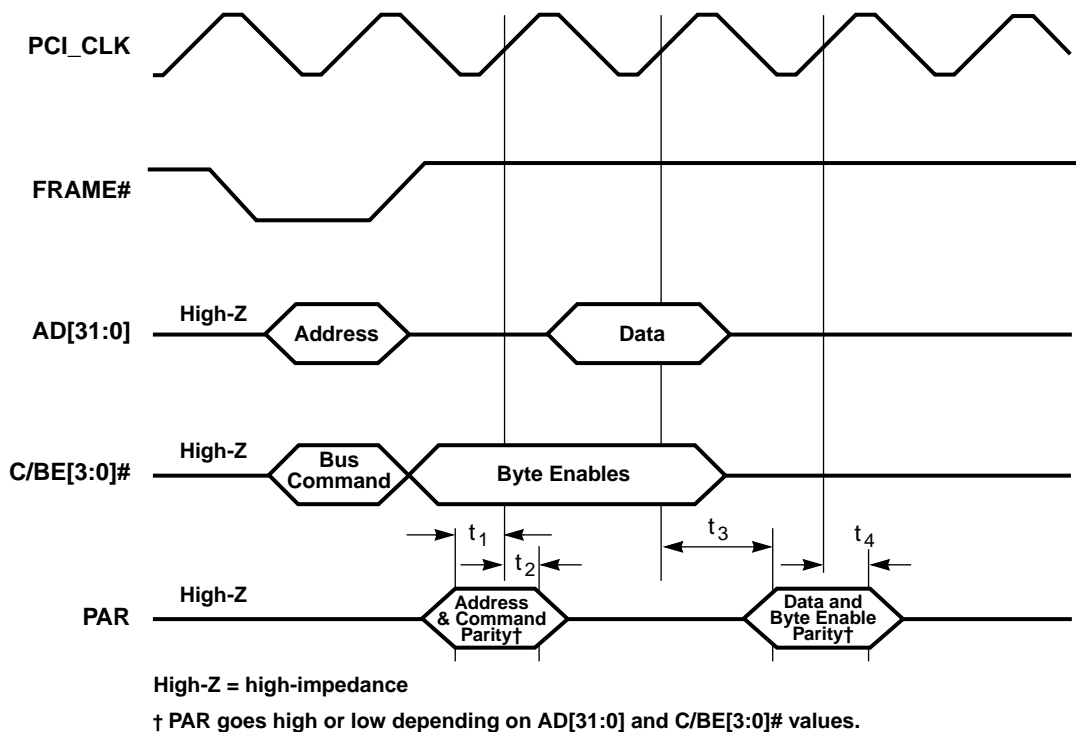


Figure 15-3. IDSEL Timing in a Configuration Cycle (PCI™ Bus)

Table 15-10. PAR Timing (PCI Bus)

Symbol	Parameter	MIN	MAX	Units
t_1	PAR setup to PCI_CLK (input to the CL-PD6833)	7	–	ns
t_2	PAR hold from PCI_CLK (input to the CL-PD6833)	0	–	ns
t_3	PAR valid delay from PCI_CLK (output from the CL-PD6833)	–	11	ns
t_4	PAR hold from PCI_CLK (output from the CL-PD6833)	0	–	ns


Figure 15-4. PAR Timing (PCI Bus)

15.3.2 System Interrupt Timing

Table 15-11. Pulse Mode Interrupt Timing

Symbol	Parameter	MIN	MAX	Units
t_1	IRQ[XX] low or high	15	18	PCI_CLK

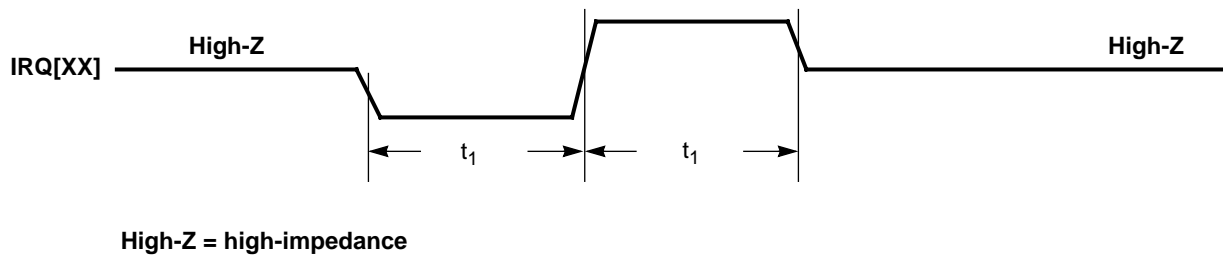


Figure 15-5. Pulse Mode Interrupt Timing

15.3.3 PC Card (PCMCIA) Bus Timing Calculations

Calculations for minimum PC Card (PCMCIA) cycle's Setup, Command, and Recovery timings are made by first calculating factors derived from the applicable timer set's timing registers and then by applying the factor to an equation relating it to the internal clock period.

The PC Card cycle timing factors, in terms of the number of internal clocks, are calculated as follows:

$$S = N_{val} + 1 \quad \text{Equation 15-1}$$

$$C = N_{val} + 1 \quad \text{Equation 15-2}$$

$$R = N_{val} + 1 \quad \text{Equation 15-3}$$

N_{val} is the specific selected multiplier value from the timer set's **Setup, Command, and Recovery Timing** registers (see [Chapter 12](#) for the description of these registers).

From this, a PC Card cycle's Setup, Command, and Recovery time for the selected timer set are calculated as follows:

$$\text{Minimum Setup time} = (S \times T_{cp}) - 10 \text{ ns} \quad \text{Equation 15-4}$$

$$\text{Minimum Command time} = (C \times T_{cp}) - 10 \text{ ns} \quad \text{Equation 15-5}$$

$$\text{Minimum Recovery time} = (R + 1) \times T_{cp} - 10 \text{ ns} \quad \text{Equation 15-6}$$

T_{cp} is the period of the internal clock.

If PCI_CLK is selected (**Misc Control 2** register bit 0 is a '0') and operates at 33 MHz, and the clock input is not being divided (**Misc Control 2** register bit 4 is a '0'), then:

$$T_{cp} = 30 \text{ ns} \quad \text{Equation 15-7}$$

The timing diagrams that follow were derived for a CL-PD6833 using the PCI clock at 33 MHz. The examples for the default values of the **Timing** registers for Timer Set 0 are as follows:

Timing Register Name (Timer Set 0)	I/O Index	Value (Default)	Resultant N_{val}
Setup Timing 0	3Ah	00h	0
Command Timing 0	3Bh	07h	7
Recovery Timing 0	3Ch	04h	4

Thus the minimum times for the default values are as follows:

$$\text{Minimum Setup time} = (S \times T_{cp}) - 10 \text{ ns} = \{[0 + 1] \times 30 \text{ ns}\} - 10 \text{ ns} = \mathbf{20 \text{ ns}} \quad \text{Equation 15-8}$$

$$\text{Minimum Command time} = (C \times T_{cp}) - 10 \text{ ns} = \{[7 + 1] \times 30 \text{ ns}\} - 10 \text{ ns} = \mathbf{230 \text{ ns}} \quad \text{Equation 15-9}$$

$$\text{Minimum Recovery time} = (R + 1) \times T_{cp} - 10 \text{ ns} = \{[5 + 1] \times 30 \text{ ns}\} - 10 \text{ ns} = \mathbf{170 \text{ ns}} \quad \text{Equation 15-10}$$

15.3.4 PC Card (PCMCIA) Bus Timing

Table 15-12. Memory Read/Write Timing

Symbol	Parameter	MIN	MAX	Units
t_1	-REG, -CE[2:1], Address, and Write Data setup to Command active ¹	$(S \times T_{cp}) - 10$		ns
t_2	Command pulse width ²	$(C \times T_{cp}) - 10$		ns
t_3	Address hold and Write Data valid from Command inactive ³	$(R \times T_{cp}) - 10$		ns
t_4	-WAIT active from Command active		$(C - 2) T_{cp} - 10$	ns
t_5	Command hold from -WAIT inactive	$2 T_{cp}$		ns
t_6	Data setup before -OE inactive	$(2 T_{cp}) + 10$		ns
t_7	Data hold after -OE inactive	0		ns
t_8	Data valid from -WAIT inactive	$T_{cp} + 10$		ns

¹ The Setup time is determined by the value programmed into the **Setup Timing** register, index 3Ah/3Dh. Using the Timer Set 0 default value of 00h, the setup time would be 20 ns. $S = N_{val} + 1$, see [page 192](#).

² The Command time is determined by the value programmed into the **Command Timing** register, index 3Bh/3Eh. Using the Timer Set 0 default value of 07h, the Command time would be 230 ns. $C = N_{val} + 1$, see [page 192](#).

³ The Recovery time is determined by the value programmed into the **Recovery Timing** register, index 3Ch/3Fh. Using the Timer Set 0 default value of 04h, the hold (Recovery) time would be 170 ns. $R = N_{val} + 1$, see [page 192](#).

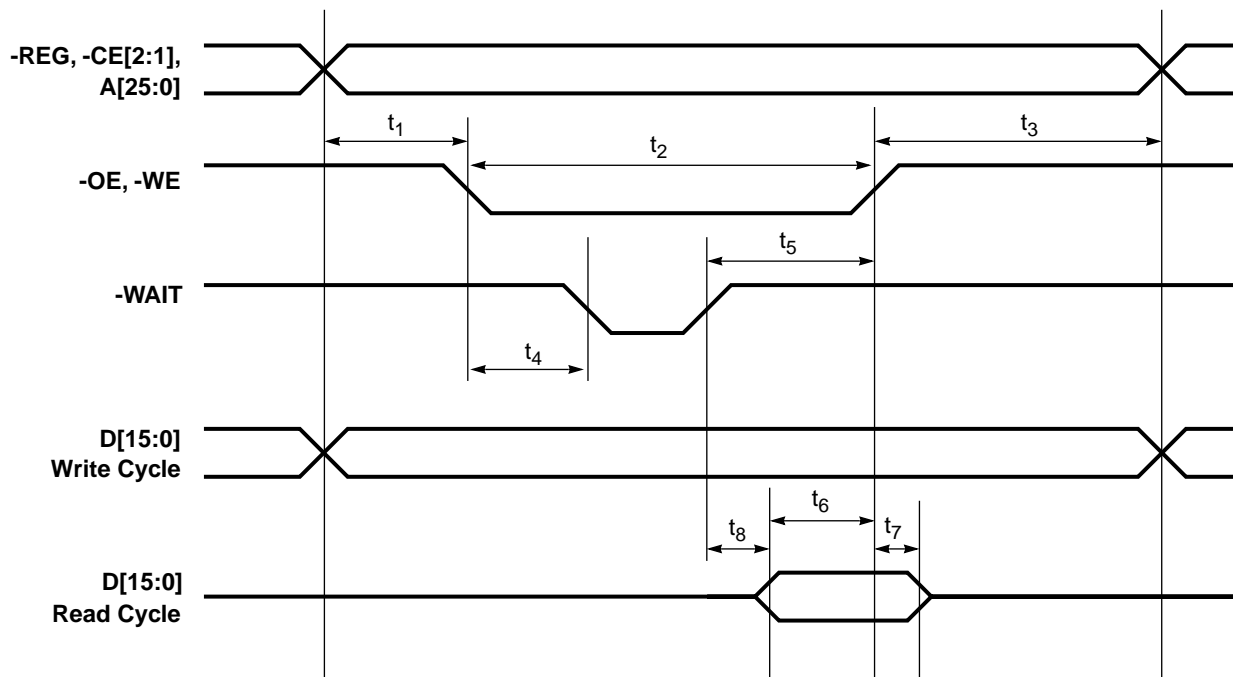


Figure 15-6. Memory Read/Write Timing

Table 15-13. Word I/O Read/Write Timing

Symbol	Parameter	MIN	MAX	Units
t ₁	-REG or Address setup to Command active ¹	$(S \times T_{cp}) - 10$		ns
t ₂	Command pulse width ²	$(C \times T_{cp}) - 10$		ns
t ₃	Address hold and Write Data valid from Command inactive ³	$(R \times T_{cp}) - 10$		ns
t ₄	-WAIT active from Command active ⁴		$(C - 2)T_{cp} - 10$	ns
t ₅	Command hold from -WAIT inactive	$(2 T_{cp}) + 10$		ns
t _{ref}	Card -IOIS16 delay from valid Address (PC Card specification)		35	ns
t ₆	-IOIS16 setup time before Command end	$(3 T_{cp}) + 10$		ns
t ₇	-CE2 delay from -IOIS16 active ⁵	$T_{cp} - 10$		ns
t ₈	Data valid from -WAIT inactive		$T_{cp} + 10$	ns
t ₉	Data setup before -IORD inactive	$(2 T_{cp}) + 10$		ns
t ₁₀	Data hold after -IORD inactive	0		ns

¹ The Setup time is determined by the value programmed into the **Setup Timing** register, index 3Ah/3Dh. Using the Timer Set 0 default value of 00h, the setup time would be 20 ns. $S = N_{val} + 1$, see [page 192](#).

² The Command time is determined by the value programmed into the **Command Timing** register, index 3Bh/3Eh. Using the Timer Set 0 default value of 07h, the Command time would be 230 ns. $C = N_{val} + 1$, see [page 192](#).

³ The Recovery time is determined by the value programmed into the **Recovery Timing** register, index 3Ch/3Fh. Using the Timer Set 0 default value of 04h, the hold (Recovery) time would be 170 ns. $R = N_{val} + 1$, see [page 192](#).

⁴ For command active timing programmed at 230 ns, maximum -WAIT timing is 100 ns after command active.

⁵ -IOIS16 must go low within $3T_{cp} + 10$ ns of the cycle beginning or -IOIS16 is ignored and -CE is not activated.

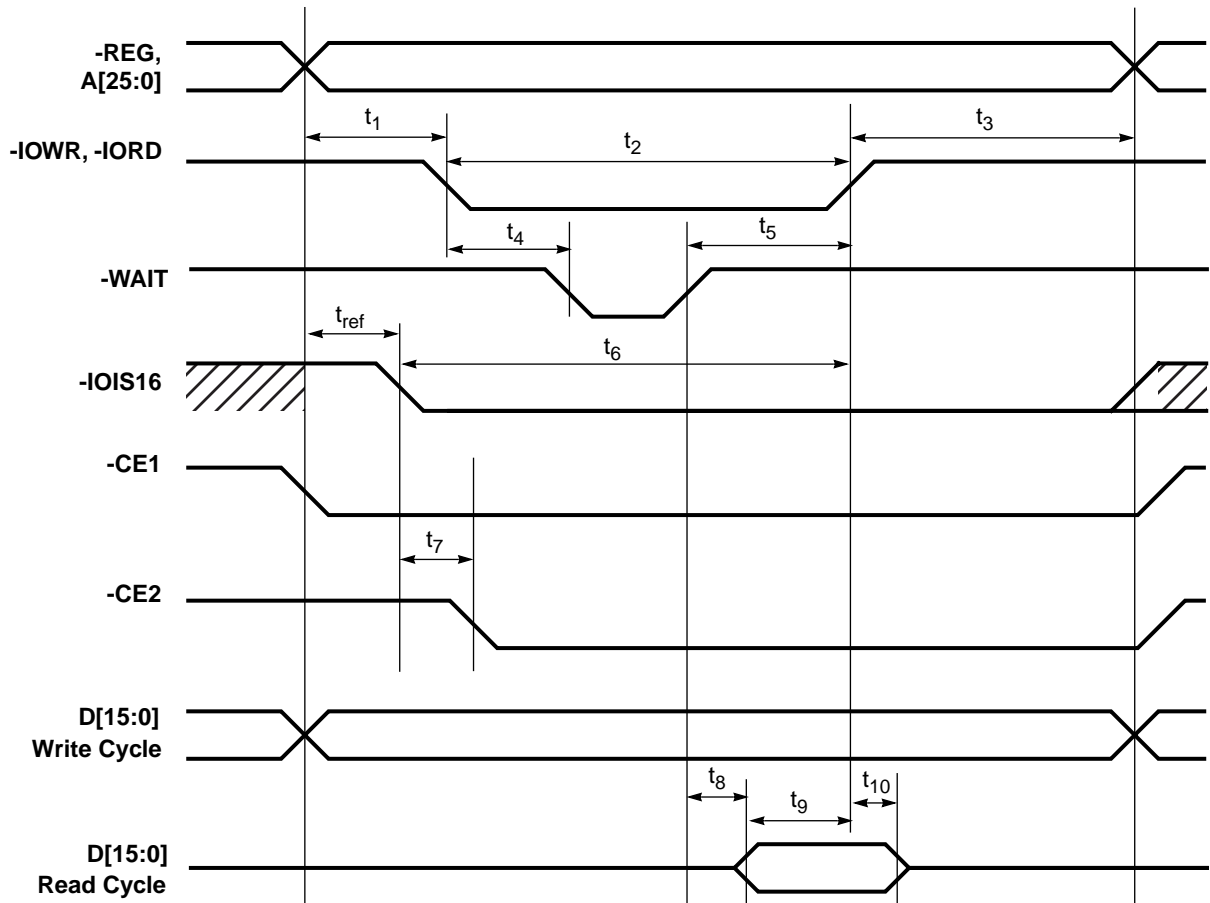


Figure 15-7. Word I/O Read/Write Timing

Table 15-14. PC Card (PCMCIA) Read/Write Timing when System is 8-Bit

Symbol	Parameter	MIN	MAX	Units
t_1	-REG or Address setup to Command active ¹	$(S \times T_{cp}) - 10$		ns
t_2	Command pulse width ²	$(C \times T_{cp}) - 10$		ns
t_3	Address hold from Command inactive ³	$(R \times T_{cp}) - 10$		ns
t_4	Data setup before Command inactive	$(2 T_{cp}) + 10$		ns
t_5	Data hold after command inactive	0		ns

¹ The Setup time is determined by the value programmed into the **Setup Timing** register, index 3Ah/3Dh. Using the Timer Set 0 default value of 00h, the setup time would be 20 ns. $S = N_{val} + 1$, see [page 192](#).

² The Command time is determined by the value programmed into the **Command Timing** register, index 3Bh/3Eh. Using the Timer Set 0 default value of 07h, the Command time would be 230 ns. $C = N_{val} + 1$, see [page 192](#).

³ The Recovery time is determined by the value programmed into the **Recovery Timing** register, index 3Ch/3Fh. Using the Timer Set 0 default value of 04h, the hold (Recovery) time would be 170 ns. $R = N_{val} + 1$, see [page 192](#).

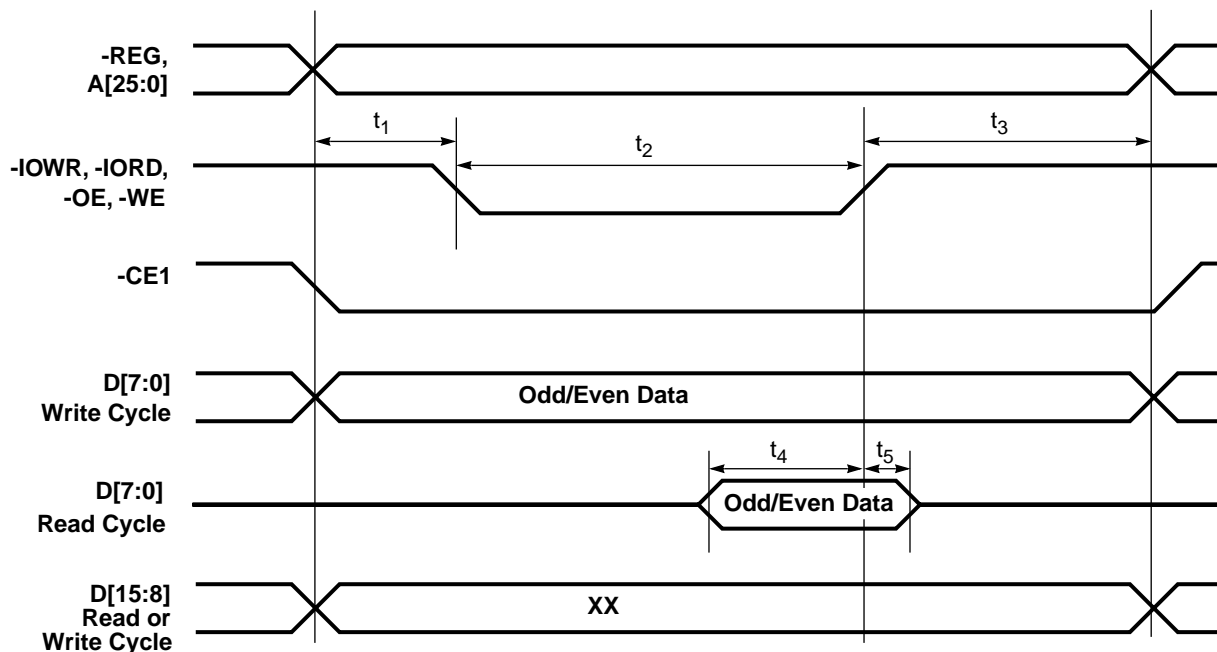

Figure 15-8. PC Card (PCMCIA) Read/Write Timing (8-Bit System)

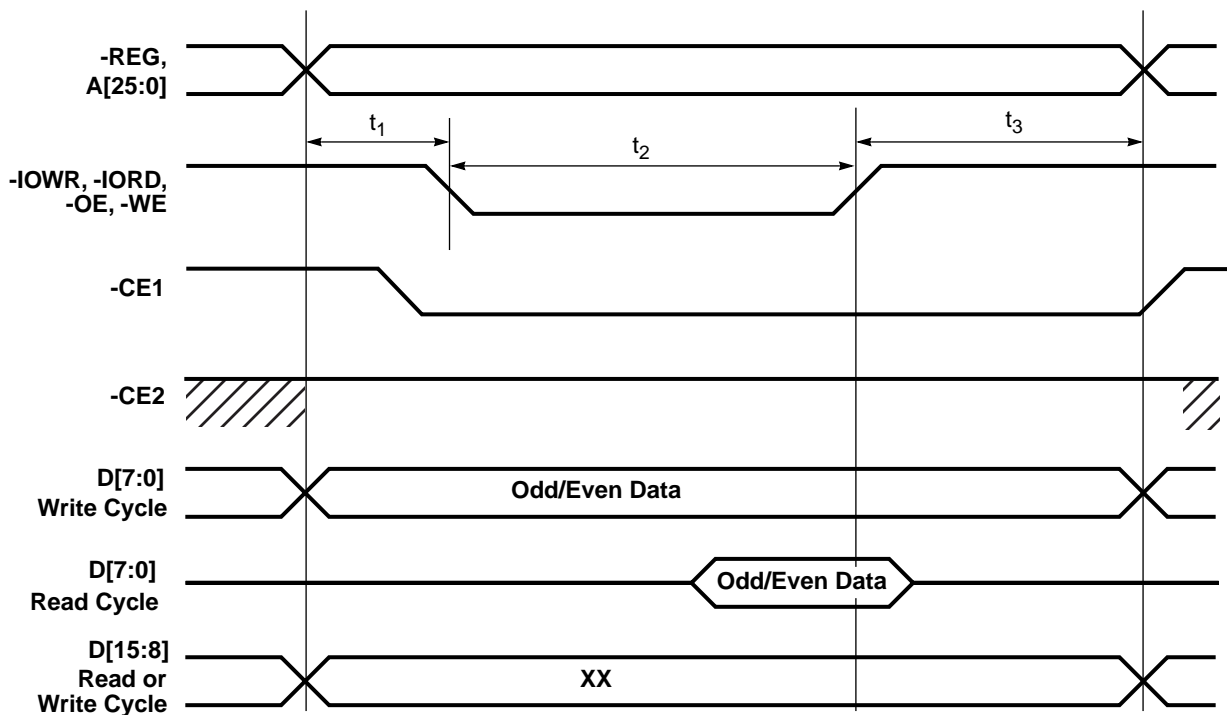
Table 15-15. Normal Byte Read/Write Timing

Symbol	Parameter	MIN	MAX	Units
t_1	Address setup to Command active ¹	$(S \times T_{cp}) - 10$		ns
t_2	Command pulse width ²	$(C \times T_{cp}) - 10$		ns
t_3	Address hold from Command inactive ³	$(R \times T_{cp}) - 10$		ns

¹ The Setup time is determined by the value programmed into the **Setup Timing** register, index 3Ah/3Dh. Using the Timer Set 0 default value of 00h, the setup time would be 20 ns. $S = N_{val} + 1$, see [page 192](#).

² The Command time is determined by the value programmed into the **Command Timing** register, index 3Bh/3Eh. Using the Timer Set 0 default value of 07h, the Command time would be 230 ns. $C = N_{val} + 1$, see [page 192](#).

³ The Recovery time is determined by the value programmed into the **Recovery Timing** register, index 3Ch/3Fh. Using the Timer Set 0 default value of 04h, the hold (Recovery) time would be 170 ns. $R = N_{val} + 1$, see [page 192](#).



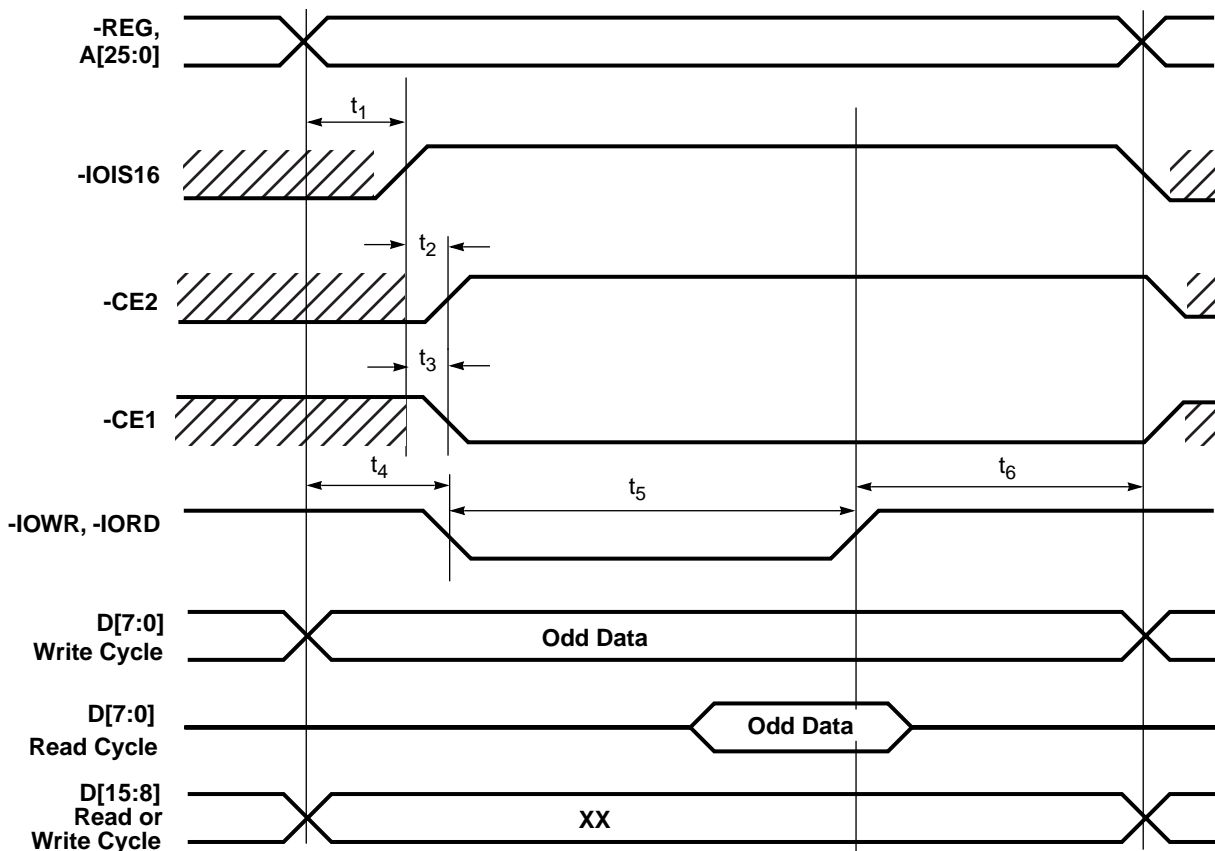
NOTE: This is the normal byte read/write timing for all other byte accesses, including odd I/O cycles where -IOIS16 is low.

Figure 15-9. Normal Byte Read/Write Timing

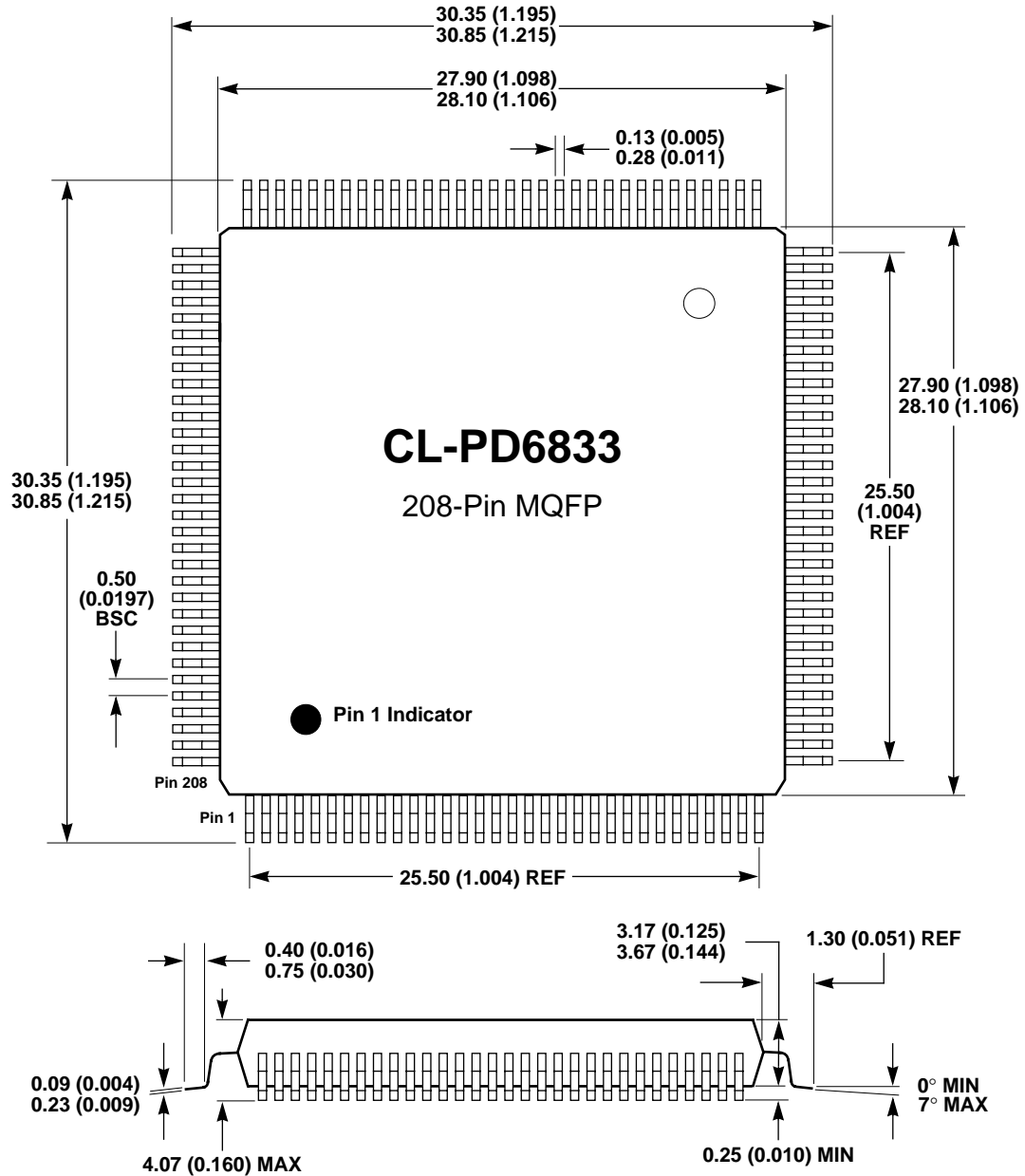
Table 15-16. 16-Bit System to 8-Bit I/O Card (Odd Byte Timing)

Symbol	Parameter	MIN	MAX	Units
t_1	Address change to -IOIS16 inactive ⁴		$(3T_{cp}) + 10$	ns
t_2	-IOIS16 inactive to -CE2 inactive		20	ns
t_3	-IOIS16 inactive to -CE1 active		20	ns
t_4	Address setup to Command active ¹	$(S \times T_{cp}) - 10$		ns
t_5	Command pulse width ²	$(C \times T_{cp}) - 10$		ns
t_6	Address hold from Command inactive ³	$(R \times T_{cp}) - 10$		ns

- ¹ The Setup time is determined by the value programmed into the **Setup Timing** register, index 3Ah/3Dh. Using the Timer Set 0 default value of 00h, the setup time would be 20 ns. $S = N_{val} + 1$, see [page 192](#).
- ² The Command time is determined by the value programmed into the **Command Timing** register, index 3Bh/3Eh. Using the Timer Set 0 default value of 07h, the Command time would be 230 ns. $C = N_{val} + 1$, see [page 192](#).
- ³ The Recovery time is determined by the value programmed into the **Recovery Timing** register, index 3Ch/3Fh. Using the Timer Set 0 default value of 04h, the hold (Recovery) time would be 170 ns. $R = N_{val} + 1$, see [page 192](#).
- ⁴ -IOIS16 level from card must be valid within 3 clocks of an address change to the card.

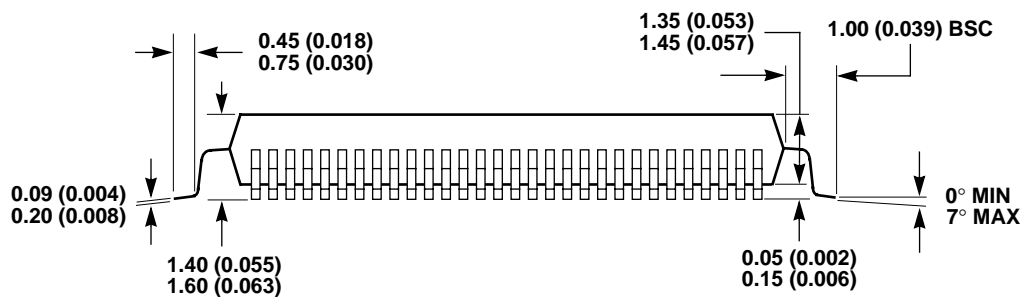
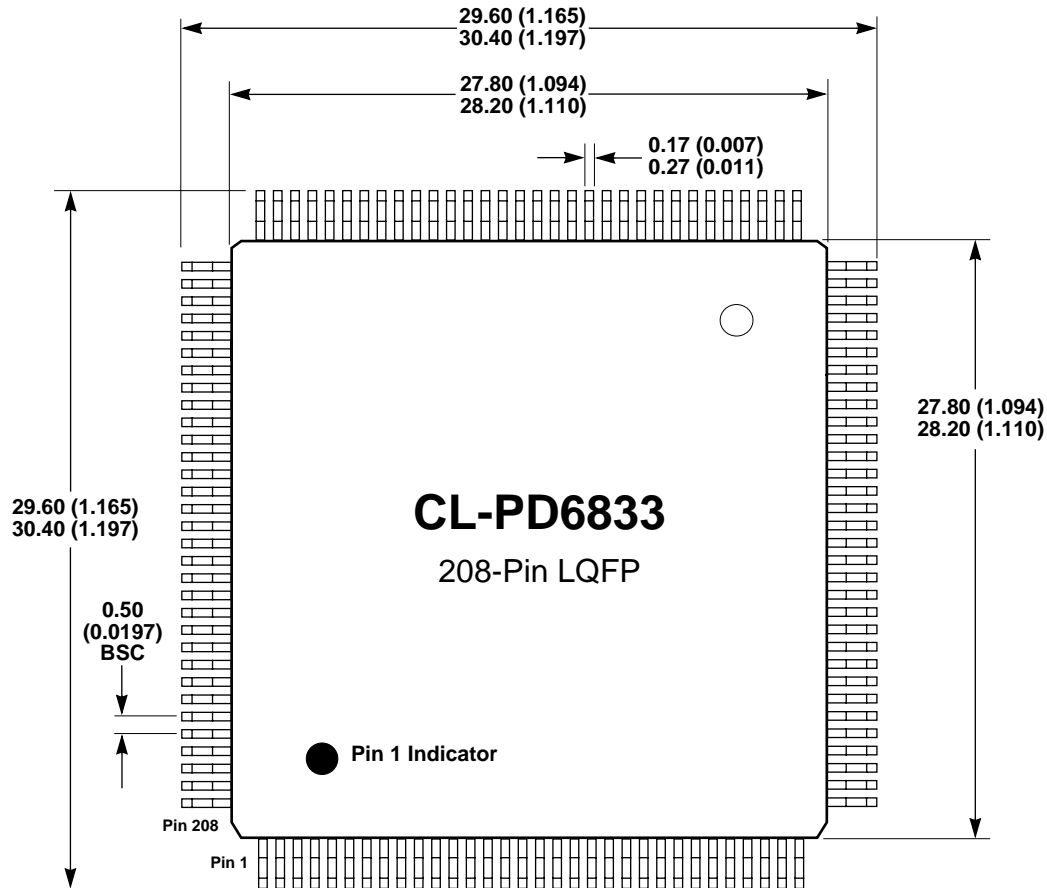

Figure 15-10. 16-Bit System to 8-Bit I/O Card (Odd Byte Timing)

16. PACKAGE SPECIFICATIONS



NOTES:

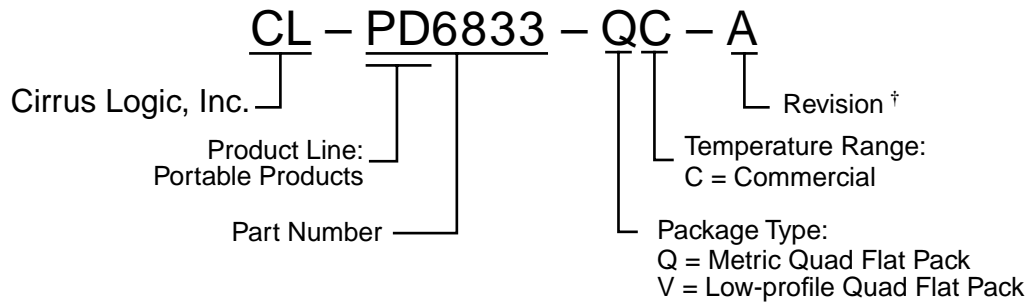
- 1) Dimensions are in millimeters (inches), and the controlling dimension is millimeter.
- 2) Drawing above does not reflect exact package pin count.
- 3) Before beginning any new design with this device, please contact Cirrus Logic for the latest package information.


NOTES:

- 1) Dimensions are in millimeters (inches), and controlling dimension is millimeter.
- 2) Drawing above does not reflect exact package pin count.
- 3) Before beginning any new design with this device, please contact Cirrus Logic for the latest package information.

17. ORDERING INFORMATION

The order number for the part is:



† Contact Cirrus Logic for up-to-date information on revisions.

Notes

Appendix A

Pin Listings

This appendix contains the following pin listings:

Table / Figure Number	Table / Figure Title	Page
Table A-1	CL-PD6833 Pin Listing in Numerical Order using PC Card 16 (R2) Signal Names	204
Table A-2	CL-PD6833 Pin Listing in Numerical Order using PC Card 32 (CardBus) Signal Names	205
Table A-3	CL-PD6833 Pin Listing in Alphabetical Order using PC Card 16 (R2) Signal Names	206
Table A-4	CL-PD6833 Pin Listing in Numerical Order using PC Card 32 (CardBus) Signal Names	207
Figure A-1	PC Card Socket Signal Names (For Reference Only)	208
Table A-5	PCI Bus Pin Listing (For Reference Only)	209

Table A-1. CL-PD6833 Pin Listing in Numerical Order using PC Card 16 (R2) Signal Names

No.	Pin Name	No.	Pin Name	No.	Pin Name	No.	Pin Name
1	PCI_CLK	54	AD2	107	A_A4	158	B_A17
2	GNT#	55	AD1	108	A_-WAIT	159	B_A13
3	REQ#	56	AD0	109	A_A3	160	B_SOCKET_VCC
4	AD31	57	RING_GND	110	A_-INPACK	161	B_A18
5	AD30	58	LOCK#	111	A_A2	162	B_A14
6	PCI_VCC	59	A_D3	112	A_-REG	163	RING_GND
7	AD29	60	A_SOCKET_VCC	113	A_A1	164	B_A19
8	AD28	61	A_-CD1	114	A_BVD2/-SPKR/-LED	165	B_-WE
9	AD27	62	A_D4	115	RING_GND	166	B_A20
10	AD26	63	A_D11	116	A_A0	167	B_RDY/-IREQ
11	AD25	64	A_D5	117	A_SOCKET_VCC	168	B_A21
12	AD24	65	A_D12	118	A_BVD1/-STSCHG/-RI	169	B_A16
13	C/BE3#	66	A_D6	119	A_D0	170	B_A22
14	RING_GND	67	A_D13	120	A_D8	171	B_A15
15	IDSEL	68	A_D7	121	A_D1	172	B_A23
16	AD23	69	A_D14	122	A_D9	173	B_A12
17	AD22	70	A_-CE1	123	A_D2	174	B_A24
18	AD21	71	A_D15	124	A_D10	175	B_A7
19	AD20	72	RING_GND	125	A_WP/-IOIS16	176	B_A25
20	AD19	73	A_A10	126	A_-CD2	177	CORE_GND
21	PCI_VCC	74	A_-CE2	127	+5V	178	B_A6
22	AD18	75	A_-OE	128	SPKR_OUT*/GPIO3	179	B_VS2
23	AD17	76	A_VS1	129	RING_GND	180	CORE_VDD
24	AD16	77	A_A11	130	SLATCH/SMBCLK	181	B_A5
25	C/BE2#	78	A_-IORD	131	SDATA/SMBDATA	182	B_RESET
26	CORE_GND	79	CORE_VDD	132	SCLK	183	B_A4
27	FRAME#	80	A_A9	133	LED_OUT*/ HW_SUSPEND#/ PME#/GPIO4	184	B_-WAIT
28	RING_GND	81	A_-IOWR	134	CORE_VDD	185	B_A3
29	IRDY#	82	A_A8	135	B_D3	186	B_-INPACK
30	TRDY#	83	A_A17	136	B_-CD1	187	B_A2
31	DEVSEL#	84	A_A13	137	B_D4	188	B_-REG#
32	STOP#	85	A_A18	138	B_D11	189	B_A1
33	PERR#	86	A_A14	139	B_D5	190	B_BVD2/-SPKR/-LED
34	SERR#	87	CORE_GND	140	B_D12	191	B_A0
35	PAR	88	A_A19	141	B_D6	192	B_BVD1/-STSCHG/-RI
36	C/BE1#	89	A_-WE	142	B_D13	193	RING_GND
37	PCI_VCC	90	A_A20	143	B_SOCKET_VCC	194	B_D0
38	AD15	91	A_RDY/-IREQ	144	B_D7	195	B_D8
39	AD14	92	A_A21	145	B_D14	196	B_D1
40	AD13	93	A_A16	146	RING_GND	197	B_D9
41	AD12	94	A_A22	147	B_-CE1	198	B_D2
42	AD11	95	A_A15	148	B_D15	199	B_D10
43	AD10	96	A_A23	149	B_A10	200	B_SOCKET_VCC
44	RING_GND	97	A_A12	150	B_-CE2	201	B_WP/-IOIS16
45	AD9	98	A_SOCKET_VCC	151	B_-OE	202	B_-CD2
46	AD8	99	A_A24	152	B_-VS1	203	INTA#/LED1*/GPIO1
47	C/BE0#	100	A_A7	153	B_A11	204	INTB#/RI_OUT*/PME#
48	AD7	101	RING_GND	154	B_-IORD	205	SOUT#/ISLD/IRQSER
49	AD6	102	A_A25	155	B_A9	206	SIN#/ISDAT/ LED2*/GPIO2
50	PCI_VCC	103	A_A6	156	B_-IOWR	207	RST#
51	AD5	104	A_VS2	157	B_A8	208	CLKRUN#
52	AD4	105	A_A5				
53	AD3	106	A_RESET				

Table A-2. CL-PD6833 Pin Listing in Numerical Order using PC Card 32 (CardBus) Signal Names

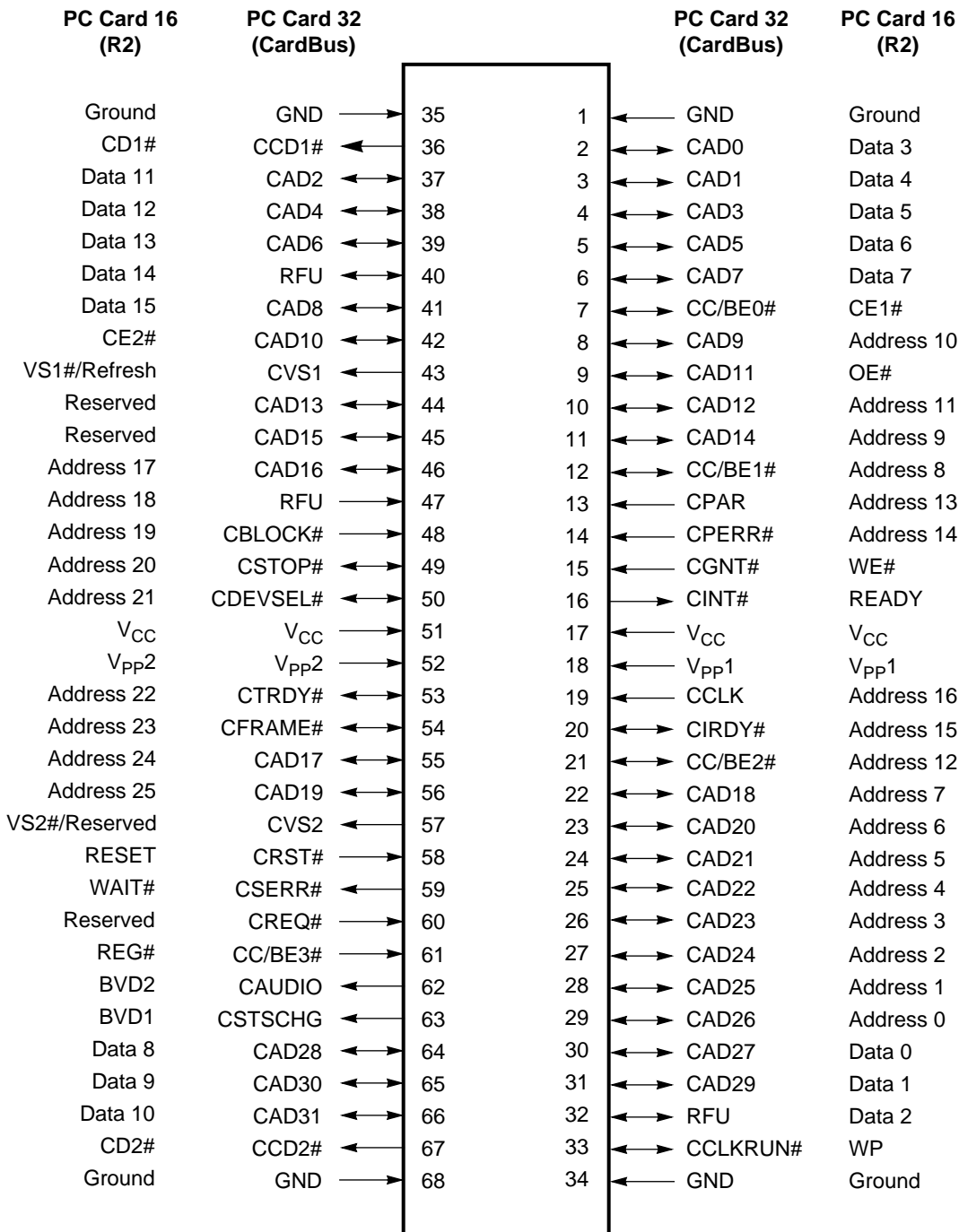
No.	Pin Name	No.	Pin Name	No.	Pin Name	No.	Pin Name
1	PCI_CLK	54	AD2	107	A_CAD22	159	B_CPAR
2	GNT#	55	AD1	108	A_CSERR#	160	B_SOCKET_VCC
3	REQ#	56	AD0	109	A_CAD23	161	B_RFU
4	AD31	57	RING_GND	110	A_CREQ#	162	B_CPERR#
5	AD30	58	LOCK#	111	A_CAD24	163	RING_GND
6	PCI_VCC	59	A_CAD0	112	A_CCBE3#	164	B_CBLOCK#
7	AD29	60	A_SOCKET_VCC	113	A_CAD25	165	B_CGNT#
8	AD28	61	A_CCD1#	114	A_AUDIO	166	B_CSTOP#
9	AD27	62	A_CAD1	115	RING_GND	167	B_CINT#
10	AD26	63	A_CAD2	116	A_CAD26	168	B_CDEVSEL#
11	AD25	64	A_CAD3	117	A_SOCKET_VCC	169	B_CCLK
12	AD24	65	A_CAD4	118	A_CSTSCHG	170	B_CTRDY#
13	C/BE3#	66	A_CAD5	119	A_CAD27	171	B_CIRDY#
14	RING_GND	67	A_CAD6	120	A_CAD28	172	B_CFRAME#
15	IDSEL	68	A_CAD7	121	A_CAD29	173	B_CCBE2#
16	AD23	69	A_RFU	122	A_CAD30	174	B_CAD17
17	AD22	70	A_CCBE0#	123	A_D2	175	B_CAD18
18	AD21	71	A_CAD8	124	A_CAD31	176	B_CAD19
19	AD20	72	RING_GND	125	A_CCLKRUN#	177	CORE_GND
20	AD19	73	A_CAD9	126	A_CCD2#	178	B_CAD20
21	PCI_VCC	74	A_CAD10	127	+5V	179	B_CVS2
22	AD18	75	A_CAD11	128	SPKR_OUT*/GPIO3	180	CORE_VDD
23	AD17	76	A_CVS1	129	RING_GND	181	B_CAD21
24	AD16	77	A_CAD12	130	SLATCH/SMBCLK	182	B_CRST#
25	C/BE2#	78	A_CAD13	131	SDATA/SMBDATA	183	B_CAD22
26	CORE_GND	79	CORE_VDD	132	SCLK	184	B_CSERR#
27	FRAME#	80	A_CAD14	133	LED_OUT*/ HW_SUSPEND#/ PME#/GPIO4	185	B_CAD23
28	RING_GND	81	A_CAD15	134	CORE_VDD	186	B_CREQ#
29	IRDY#	82	A_CCBE1#	135	B_CAD0	187	B_CAD24
30	TRDY#	83	A_CAD16	136	B_CCD1#	188	B_CCBE3#
31	DEVSEL#	84	A_CPAR	137	B_CAD1	189	B_CAD25
32	STOP#	85	A_RFU	138	B_CAD2	190	B_AUDIO
33	PERR#	86	A_CPERR#	139	B_CAD3	191	B_CAD26
34	SERR#	87	CORE_GND	140	B_CAD4	192	B_CSTSCHG
35	PAR	88	A_CBLOCK#	141	B_CAD5	193	RING_GND
36	C/BE1#	89	A_CGNT#	142	B_CAD6	194	B_CAD27
37	PCI_VCC	90	A_CSTOP#	143	B_SOCKET_VCC	195	B_CAD28
38	AD15	91	A_CINT#	144	B_CAD7	196	B_CAD29
39	AD14	92	A_CDEVSEL#	145	B_RFU	197	B_CAD30
40	AD13	93	A_CCLK	146	RING_GND	198	B_RFU
41	AD12	94	A_CTRDY#	147	B_CCBE0#	199	B_CAD31
42	AD11	95	A_CIRDY#	148	B_CAD8	200	B_SOCKET_VCC
43	AD10	96	A_CFRAME#	149	B_CAD9	201	B_CCLKRUN#
44	RING_GND	97	A_CCBE2#	150	B_CAD10	202	B_CCD2#
45	AD9	98	A_SOCKET_VCC	151	B_CAD11	203	INTA#/LED1*/GPIO1
46	AD8	99	A_CAD17	152	B_CVS1	204	INTB#/RI_OUT*/PME#
47	C/BE0#	100	A_CAD18	153	B_CAD12	205	SOUT#/ISLD/IRQSER
48	AD7	101	RING_GND	154	B_CAD13	206	SIN#/ISDAT/ LED2*/GPIO2
49	AD6	102	A_CAD19	155	B_CAD14	207	RST#
50	PCI_VCC	103	A_CAD20	156	B_CAD15	208	CLKRUN#
51	AD5	104	A_CVS2	157	B_CCBE1#		
52	AD4	105	A_CAD21	158	B_CAD16		
53	AD3	106	A_CRST#				

Table A-3. CL-PD6833 Pin Listing in Alphabetical Order using PC Card 16 (R2) Signal Names

Pin Name	No.	Pin Name	No.	Pin Name	No.	Pin Name	No.
A_A0	116	A_-REG	112	B_A11	153	C/BE1#	36
A_A1	113	A_RESET	106	B_A12	173	C/BE2#	25
A_A2	111	A_VS1	76	B_A13	159	C/BE3#	13
A_A3	109	A_VS2	104	B_A14	162	CLKRUN#	208
A_A4	107	A_-WAIT	108	B_A15	171	CORE_GND	26
A_A5	105	A_-WE	89	B_A16	169	CORE_GND	87
A_A6	103	A_WP/-IOIS16	125	B_A17	158	CORE_GND	177
A_A7	100	A_SOCKET_VCC	60	B_A18	161	CORE_VDD	79
A_A8	82	A_SOCKET_VCC	98	B_A19	164	CORE_VDD	134
A_A9	80	A_SOCKET_VCC	117	B_A20	166	CORE_VDD	180
A_A10	73	AD0	56	B_A21	168	DEVSEL#	31
A_A11	77	AD1	55	B_A22	170	FRAME#	27
A_A12	97	AD2	54	B_A23	172	GNT#	2
A_A13	84	AD3	53	B_A24	174	IDSEL	15
A_A14	86	AD4	52	B_A25	176	IRDY#	29
A_A15	95	AD5	51	B_BVD1/-STSCHG/-RI	192	INTA#/LED1*/GPIO1	203
A_A16	93	AD6	49	B_BVD2/-SPKR/-LED	190	INTB#/RI_OUT*/PME#	204
A_A17	83	AD7	48	B_-CD1	136	LED_OUT*/HW_SUSPEND#/PME#/GPIO4	133
A_A18	85	AD8	46	B_-CD2	202	LOCK#	58
A_A19	88	AD9	45	B_-CE1	147	PAR	35
A_A20	90	AD10	43	B_-CE2	150	PCI_CLK	1
A_A21	92	AD11	42	B_D0	194	PCI_VCC	6
A_A22	94	AD12	41	B_D1	196	PCI_VCC	21
A_A23	96	AD13	40	B_D2	198	PCI_VCC	37
A_A24	99	AD14	39	B_D3	135	PCI_VCC	50
A_A25	102	AD15	38	B_D4	137	PERR#	33
A_BVD1/-STSCHG/-RI	118	AD16	24	B_D5	139	REQ#	3
A_BVD2/-SPKR/-LED	114	AD17	23	B_D6	141	RING_GND	14
A_-CD1	61	AD18	22	B_D7	144	RING_GND	28
A_-CD2	126	AD19	20	B_D8	195	RING_GND	44
A_-CE1	70	AD20	19	B_D9	197	RING_GND	57
A_-CE2	74	AD21	18	B_D10	199	RING_GND	72
A_D0	119	AD22	17	B_D11	138	RING_GND	101
A_D1	121	AD23	16	B_D12	140	RING_GND	115
A_D2	123	AD24	12	B_D13	142	RING_GND	129
A_D3	59	AD25	11	B_D14	145	RING_GND	146
A_D4	62	AD26	10	B_D15	148	RING_GND	163
A_D5	64	AD27	9	B_-INPACK	186	RING_GND	193
A_D6	66	AD28	8	B_-IORD	154	RST#	207
A_D7	68	AD29	7	B_-IOWR	156	SCLK	132
A_D8	120	AD30	5	B_-OE	151	SDATA/SMBDATA	131
A_D9	122	AD31	4	B_RDY/-IREQ	167	SERR#	34
A_D10	124	B_A0	191	B_-REG#	188	SIN#/ISDAT/LED2*/GPIO2	206
A_D11	63	B_A1	189	B_RESET	182	SLATCH/SMBCLK	130
A_D12	65	B_A2	187	B_VS1	152	SOUT#/ISLD/IRQSER	205
A_D13	67	B_A3	185	B_VS2	179	SPKR_OUT*/GPIO3	128
A_D14	69	B_A4	183	B_-WAIT	184	STOP#	32
A_D15	71	B_A5	181	B_-WE	165	TRDY#	30
A_-INPACK	110	B_A6	178	B_WP/-IOIS16	201	+5V	127
A_-IORD	78	B_A7	175	B_SOCKET_VCC	143		
A_-IOWR	81	B_A8	157	B_SOCKET_VCC	160		
A_-OE	75	B_A9	155	B_SOCKET_VCC	200		
A_RDY/-IREQ	91	B_A10	149	C/BE0#	47		

Table A-4. CL-PD6833 Pin Listing in Alphabetical Order using PC Card 32 (CardBus) Signal Names

Pin Name	No.	Pin Name	No.	Pin Name	No.	Pin Name	No.
A_CAD0	59	A_CSTSCHG	118	B_CAD11	151	C/BE1#	36
A_CAD1	62	A_CTRDY#	94	B_CAD12	153	C/BE2#	25
A_CAD2	63	A_CVS1	76	B_CAD13	154	C/BE3#	13
A_CAD3	64	A_CVS2	104	B_CAD14	155	CLKRUN#	208
A_CAD4	65	A_D2	123	B_CAD15	156	CORE_GND	26
A_CAD5	66	A_RFU	69	B_CAD16	158	CORE_GND	87
A_CAD6	67	A_RFU	85	B_CAD17	174	CORE_GND	177
A_CAD7	68	A_SOCKET_VCC	60	B_CAD18	175	CORE_VDD	79
A_CAD8	71	A_SOCKET_VCC	98	B_CAD19	176	CORE_VDD	134
A_CAD9	73	A_SOCKET_VCC	117	B_CAD20	178	CORE_VDD	180
A_CAD10	74	AD0	56	B_CAD21	181	DEVSEL#	31
A_CAD11	75	AD1	55	B_CAD22	183	FRAME#	27
A_CAD12	77	AD2	54	B_CAD23	185	GNT#	2
A_CAD13	78	AD3	53	B_CAD24	187	IDSEL	15
A_CAD14	80	AD4	52	B_CAD25	189	IRDY#	29
A_CAD15	81	AD5	51	B_CAD26	191	INTA#/LED1*/GPIO1	203
A_CAD16	83	AD6	49	B_CAD27	194	INTB#/RI_OUT*/PME#	204
A_CAD17	99	AD7	48	B_CAD28	195	LED_OUT*/HW_SUSPEND#/PME#/GPIO4	133
A_CAD18	100	AD8	46	B_CAD29	196	LOCK#	58
A_CAD19	102	AD9	45	B_CAD30	197	PAR	35
A_CAD20	103	AD10	43	B_CAD31	199	PCI_CLK	1
A_CAD21	105	AD11	42	B_CAUDIO	190	PCI_VCC	6
A_CAD22	107	AD12	41	B_CBLOCK#	164	PCI_VCC	21
A_CAD23	109	AD13	40	B_CCBE0#	147	PCI_VCC	37
A_CAD24	111	AD14	39	B_CCBE1#	157	PCI_VCC	50
A_CAD25	113	AD15	38	B_CCBE2#	173	PERR#	33
A_CAD26	116	AD16	24	B_CCBE3#	188	REQ#	3
A_CAD27	119	AD17	23	B_CCD1#	136	RING_GND	14
A_CAD28	120	AD18	22	B_CCD2#	202	RING_GND	28
A_CAD29	121	AD19	20	B_CCLK	169	RING_GND	44
A_CAD30	122	AD20	19	B_CCLKRUN#	201	RING_GND	57
A_CAD31	124	AD21	18	B_CDEVSEL#	168	RING_GND	72
A_CAUDIO	114	AD22	17	B_CFRAME#	172	RING_GND	101
A_CBLOCK#	88	AD23	16	B_CGNT#	165	RING_GND	115
A_CCBE0#	70	AD24	12	B_CINT#	167	RING_GND	129
A_CCBE1#	82	AD25	11	B_CIRDY#	171	RING_GND	146
A_CCBE2#	97	AD26	10	B_CPAR	159	RING_GND	163
A_CCBE3#	112	AD27	9	B_CPERR#	162	RING_GND	193
A_CCD1#	61	AD28	8	B_CREQ#	186	RST#	207
A_CCD2#	126	AD29	7	B_CRST#	182	SCLK	132
A_CCLK	93	AD30	5	B_CSERR#	184	SDATA/SMBDATA	131
A_CCLKRUN#	125	AD31	4	B_STOP#	166	SERR#	34
A_CDEVSEL#	92	B_CAD0	135	B_CSTSCHG	192	SIN#/ISDAT/LED2*/GPIO2	206
A_CFRAME#	96	B_CAD1	137	B_SOCKET_VCC	143	SLATCH/SMBCLK	130
A_CGNT#	89	B_CAD2	138	B_SOCKET_VCC	160	SOUT#/ISLD/IRQSER	205
A_CINT#	91	B_CAD3	139	B_SOCKET_VCC	200	SPKR_OUT*/GPIO3	128
A_CIRDY#	95	B_CAD4	140	B_CTRDY#	170	STOP#	32
A_CPAR	84	B_CAD5	141	B_CVS1	152	TRDY#	30
A_CPERR#	86	B_CAD6	142	B_CVS2	179	+5V	127
A_CREQ#	110	B_CAD7	144	B_RFU	145		
A_CRST#	106	B_CAD8	148	B_RFU	161		
A_CSERR#	108	B_CAD9	149	B_RFU	198		
A_CSTOP#	90	B_CAD10	150	C/BE0#	47		



NOTE: RFU is 'reserved for future use'. VS1# was named Refresh in PCMCIA 2.1.

Figure A-1. PC Card Socket Signal Names (For Reference Only)

Table A-5. PCI Bus Pin Listing (For Reference Only)

Pin	5-V Board		Universal Board		3.3-V Board	
	Side B	Side A	Side B	Side A	Side B	Side A
1	+12V	TRST#	+12V	TRST#	+12V	TRST#
2	TCK	+12V	TCK	+12V	TCK	+12V
3	Ground	TMS	Ground	TMS	Ground	TMS
4	TDO	TDI	TDO	TDI	TDO	TDI
5	+5V	+5V	+5V	+5V	+5V	+5V
6	+5V	INTA#	+5V	INTA#	+5V	INTA#
7	INTB#	INTC#	INTB#	INTC#	INTB#	INTC#
8	INTD#	+5V	INTD#	+5V	INTD#	+5V
9	PRSNT1#	Reserved	PRSNT1#	Reserved	PRSNT1#	Reserved
10	Reserved	+5V	Reserved	+V _{I/O}	Reserved	+3.3V
11	PRSNT2#	Reserved	PRSNT2#	Reserved	PRSNT2#	Reserved
12	Ground	Ground	Keyway		Keyway	
13	Ground	Ground	Keyway		Keyway	
14	Reserved	Reserved	Reserved	Reserved	Reserved	Reserved
15	Ground	RST#	Ground	RST#	Ground	RST#
16	CLK	+5V	CLK	+V _{I/O}	CLK	+3.3V
17	Ground	GNT#	Ground	GNT#	Ground	GNT#
18	REQ#	Ground	REQ#	Ground	REQ#	Ground
19	+5V	Ground	+V _{I/O}	Ground	+3.3V	Ground
20	AD[31]	AD[30]	AD[31]	AD[30]	AD[31]	AD[30]
21	AD[29]	+3.3V	AD[29]	+3.3V	AD[29]	+3.3V
22	Ground	AD[28]	Ground	AD[28]	Ground	AD[28]
23	AD[27]	AD[26]	AD[27]	AD[26]	AD[27]	AD[26]
24	AD[25]	Ground	AD[25]	Ground	AD[25]	Ground
25	+3.3V	AD[24]	+3.3V	AD[24]	+3.3V	AD[24]
26	C/BE[3]#	IDSEL	C/BE[3]#	IDSEL	C/BE[3]#	IDSEL
27	AD[23]	+3.3V	AD[23]	+3.3V	AD[23]	+3.3V
28	Ground	AD[22]	Ground	AD[22]	Ground	AD[22]
29	AD[21]	AD[20]	AD[21]	AD[20]	AD[21]	AD[20]
30	AD[19]	Ground	AD[19]	Ground	AD[19]	Ground
31	+3.3V	AD[18]	+3.3V	AD[18]	+3.3V	AD[18]
32	AD[17]	AD[16]	AD[17]	AD[16]	AD[17]	AD[16]
33	C/BE[2]#	+3.3V	C/BE[2]#	+3.3V	C/BE[2]#	+3.3V

Table A-5. PCI Bus Pin Listing (For Reference Only) (cont.)

Pin	5-V Board		Universal Board		3.3-V Board	
	Side B	Side A	Side B	Side A	Side B	Side A
34	Ground	FRAME#	Ground	FRAME#	Ground	FRAME#
35	IRDY#	Ground	IRDY#	Ground	IRDY#	Ground
36	+3.3V	TRDY#	+3.3V	TRDY#	+3.3V	TRDY#
37	DEVSEL#	Ground	DEVSEL#	Ground	DEVSEL#	Ground
38	Ground	STOP#	Ground	STOP#	Ground	STOP#
39	LOCK#	+3.3V	LOCK#	+3.3V	LOCK#	+3.3V
40	PERR#	SDONE	PERR#	SDONE	PERR#	SDONE
41	+3.3V	SBO#	+3.3V	SBO#	+3.3V	SBO#
42	SERR#	Ground	SERR#	Ground	SERR#	Ground
43	+3.3V	PAR	+3.3V	PAR	+3.3V	PAR
44	C/BE[1]#	AD[15]	C/BE[1]#	AD[15]	C/BE[1]#	AD[15]
45	AD[14]	+3.3V	AD[14]	+3.3V	AD[14]	+3.3V
46	Ground	AD[13]	Ground	AD[13]	Ground	AD[13]
47	AD[12]	AD[11]	AD[12]	AD[11]	AD[12]	AD[11]
48	AD[10]	Ground	AD[10]	Ground	AD[10]	Ground
49	Ground	AD[09]	M66EN	AD[09]	M66EN	AD[09]
50	Keyway		Keyway		Ground	Ground
51	Keyway		Keyway		Ground	Ground
52	AD[08]	C/BE[0]#	AD[08]	C/BE[0]#	AD[08]	C/BE[0]#
53	AD[07]	+3.3V	AD[07]	+3.3V	AD[07]	+3.3V
54	+3.3V	AD[08]	+3.3V	AD[08]	+3.3V	AD[08]
55	AD[05]	AD[04]	AD[05]	AD[04]	AD[05]	AD[04]
56	AD[03]	Ground	AD[03]	Ground	AD[03]	Ground
57	Ground	AD[02]	Ground	AD[02]	Ground	AD[02]
58	AD[01]	AD[00]	AD[01]	AD[00]	AD[01]	AD[00]
59	+5V	+5V	+V _{I/O}	+V _{I/O}	+3.3V	+3.3V
60	ACK64#	ACK64#	ACK64#	REQ64#	ACK64#	REQ64#
61	+5V	+5V	+5V	+5V	+5V	+5V
62	+5V	+5V	+5V	+5V	+5V	+5V

Index

Numerics

- 8-bit register
 - example 42
 - structure 42

A

- abbreviations 7
- absolute maximum ratings 181
- AC specifications 185–198
- acronyms 7
- application notes, related
 - Configuring PCMCIA Sockets for ATA Drive Interface (AN-PD5)* 179
 - Interrupt Signalling Modes for the CL-PD6730 and CL-PD6832 (AN-PD8)* 32
 - Zoomed Video Port Implementation (AN-PD10)* 29
- ATA disk interface 179
- ATA mode
 - operation 37, 179
 - pin cross-reference 179
- attribute memory 25

B

- bit
 - naming conventions 7
 - numbering conventions 7
- bus sizing 37

C

- card
 - detect 38
 - insertion 37
 - removal 36
 - voltage sense 38
- CardBus cards. *See* PC Card 32 (CardBus)
- CardBus registers
 - Control 82
 - Event Force 80
 - Present State 78
 - Status Event 75
 - Status Mask 77
- common memory 25
- conventions
 - abbreviations 7
 - acronyms 7
 - bit naming 7, 45
 - bit numbering 7

- internal registers 7
- numbers and units 8
- pin naming 12
- register bit types 45
- register headings 45
- special function bits 45

D

- DC specifications
 - general 181
 - general I/O pin for 2-, 4-, 8-, and 16-mA class outputs 183
 - operating current specifications (3.3 V) 184
 - PC Card (PCMCIA) bus interface 182
 - PCI bus interface 183
- Device Control registers
 - Card Status Change 98
 - Chip Revision 91
 - Interface Status 92
 - Interrupt and General Control 96
 - Management Interrupt Configuration 99
 - Mapping Enable 101
 - Power Control 94
- device identification and implementation scheme 159
- DMA
 - PCI/Way 34
 - transfer size 70
- DMA Operation registers
 - DMA Command and Status 175
 - High Address 173
 - High Count 174
 - Low Address 172
 - Low Count 174
 - Mask 178
 - Master Clear 178
 - Mid Count 174
 - Mid High Address 173
 - Mid Low Address 172
 - Mode 177
 - Request 176

E

- electrical specifications
 - absolute maximum ratings 181
 - AC timing specifications 185–198
 - DC specifications. *See* DC specifications
- Extension registers
 - ATA Control 138

- Chip Information 137
 - Device Identification and Implementation Scheme
 - Device Capability Byte A 161
 - Device Capability Byte B 162
 - Device Implementation Byte A 163
 - Device Implementation Byte B 164
 - Device Implementation Byte C 165
 - Device Implementation Byte D 166
 - Mask Revision Byte 159
 - Product ID Byte 160
 - Extended Data 141
 - Extension Control 1 142
 - Gen Map 0–6 Upper Address (Memory) 143
 - GPIO Input Control 147
 - GPIO Input Data 148
 - GPIO Output Control 147
 - GPIO Output Data 148
 - Pin Multiplex Control 0 144
 - Pin Multiplex Control 1 146
 - Extended Index 140
 - FIFO Control 134
 - Misc Control 1 132
 - Misc Control 2 136
 - Prefetch Window 149
 - Extension Card Status Change 156
 - Gen Map 0–6 Extra Control (I/O) 154
 - Gen Map 0–6 Extra Control (Memory) 155
 - Misc Control 3 151
 - Misc Control 4 157
 - Misc Control 5 158
 - Misc Control 6 158
 - PC Card Space Control 150
 - PCI Space Control 149
 - SMB Socket Power Control Address 153
 - Window Type Select 150
 - External-Hardware serial signalling mode 36
- G**
- general interface pins 21–23
 - General Mapping registers (for I/O mode). *See* General Window Mapping registers
 - General Mapping registers (for Memory mode). *See* General Window Mapping registers
 - General Window Mapping registers
 - General Mapping (for I/O mode)
 - Gen Map 0–6 End Address High (I/O) 122
 - Gen Map 0–6 End Address Low (I/O) 121
 - Gen Map 0–6 Offset Address High (I/O) 124
 - Gen Map 0–6 Offset Address Low (I/O) 123
 - Gen Map 0–6 Start Address High (I/O) 120
 - Gen Map 0–6 Start Address Low (I/O) 119
 - General Mapping (for Memory mode)
 - Gen Map 0–6 End Address High (Memory) 128
 - Gen Map 0–6 End Address Low (Memory) 127
 - Gen Map 0–6 Offset Address High (Memory) 130
 - Gen Map 0–6 Offset Address Low (Memory) 129
 - Gen Map 0–6 Start Address High (Memory) 126
 - Gen Map 0–6 Start Address Low (Memory) 125
 - ground pins 24
- H**
- Hardware Suspend mode 34
 - host access to registers 42
- I**
- I/O Window Mapping registers. *See* Window Mapping registers
 - I/O window options 27
 - I/O-to-I/O window 28
 - I/O-to-memory window 29
 - IDE. *See* ATA disk interface
 - Index register 42
 - interrupt signalling 151
 - interrupt signalling mode
 - External-Hardware 32
 - overview 31
 - PC/PCI Serial 33
 - PCI 33
 - PCI/Way 32
 - interrupts
 - classes 31
 - management 31
 - overview 30
 - socket or card 31
- M**
- mask revision 159
 - memory map windows 110
 - Memory Window Mapping register. *See* Window Mapping registers
 - memory window options 26
 - memory-to-I/O window 28
 - memory-to-memory window 27
 - modes
 - ATA. *See* ATA mode
 - External-Hardware serial signalling 36
 - Hardware Suspend 34
 - interrupt signalling. *See* interrupt signalling mode
 - Memory-Mapped 44
 - request 177

- System Management Bus signalling 36
 - Texas Instruments TPS2202AIDF serial signalling 35
 - transfer 177
- O**
- Operation registers
 - Data 90
 - Index 85–86
 - ordering information 201
- P**
- package specifications 199
 - PC Card
 - definition 25
 - enabling output signals to socket 94
 - PC Card Standard 25
 - sensing 37
 - socket signal names 208
 - timing 37
 - PC Card (PCMCIA) bus timing
 - 16-bit system to 8-bit I/O card (odd byte timing) 198
 - memory read/write timing 193
 - normal byte read/write timing 197
 - PC Card (PCMCIA) read/write timing when system is 8-bit 196
 - word I/O read/write timing 194–195
 - PC Card 16 (R2)
 - attribute memory 25
 - common memory 25
 - description 25
 - I/O-type cards 25
 - memory-type cards 25
 - pin diagram 10
 - signal names 204, 206
 - windowing capabilities 26
 - PC Card 32 (CardBus)
 - description 25
 - pin diagram 11
 - signal names 205, 207
 - PCI bus interface pins 13–15
 - PCI bus pin listing 209
 - PCI bus timing
 - FRAME#, AD[31:0], C/BE[3:0]#, and DEVSEL# 186–187
 - IDSEL timing in a configuration cycle 189
 - PAR timing (PCI bus) 190
 - TRDY# and STOP# Delay 188
 - PCI Configuration registers
 - Cache Line Size, Latency Timer, Header Type, and BIST 53
 - CardBus Status 55
 - Command and Status 49
 - Configuration Miscellaneous 1 73
 - DMA Slave Configuration 70
 - I/O Base 0–1 60
 - I/O Limit 0–1 61
 - Interrupt Line, Interrupt Pin, and Bridge Control 62
 - Memory Base 0–1 58
 - Memory Base Address 54
 - Memory Limit 0–1 59
 - PC Card 16-Bit IF Legacy Mode Base Address 66
 - PCI Bus Number, CardBus Number, Subordinate Bus Number, and CardBus Latency Timer 57
 - Power Management 67
 - Power Management Control and Status 68
 - Revision ID and Class Code 52
 - Socket Number 71
 - Subsystem Vendor ID and Subsystem Device ID 65
 - Vendor ID and Device ID 48
 - PCI/Way DMA 34
 - PCMCIA 25
 - pin information
 - A_pin name 15
 - ATA pin cross-reference 179
 - B_pin name 15
 - conventions 12
 - general interface pins 21–23
 - ground pins 24
 - PC Card socket signal names 208
 - PCI bus interface pins 13–15
 - pin diagrams 10–11
 - pin listings 203–210
 - power control pins 21–23
 - power pins 24
 - socket interface pins 15–21
 - power control pins 21–23
 - power management 34
 - power pins 24
 - power-on setup 44
 - pulse mode interrupt timing 191
- R**
- R2 cards. *See* PC Card 16 (R2)
 - registers
 - CardBus. *See* CardBus registers
 - conventions 7
 - Device Control. *See* Device Control registers
 - DMA Operation. *See* DMA Operation registers
 - Extended Data 43
 - Extended Index 43
 - Extension. *See* Extension registers

General Window Mapping. *See* General Window Mapping registers
host access to 42
Index register 42
Operation. *See* Operation registers
PCI Configuration. *See* PCI Configuration registers
Timing. *See* Timing registers
Window Mapping. *See* Window Mapping registers
request mode 177

S

socket interface pins 15–21
socket interface power state 68
socket number 71
socket power
 commands, enabling 94
 control 35
 control configuration 35
 management features 35
system architecture 25
system interrupt timing 191
System Management Bus signalling mode 36

T

Texas Instruments TPS2202AIDF serial signalling mode 35
timing
 AC timing specifications 185–198
 PC Card 37
 PC Card (PCMCIA) bus timing calculations 192
 PC Card (PCMCIA) bus timing. *See* PC Card (PCMCIA) bus timing
 PCI bus timing. *See* PCI bus timing
 pulse mode timing 191
 system interrupt timing 191
Timing registers
 Command Timing 0–1 168
 Recovery Timing 0–1 169
 Setup Timing 0–1 167
transfer mode 177

U

upgrading from the CL-PD6832 38

W

Window Mapping registers
 I/O Window Mapping
 Card I/O Map 0–1 Offset Address High 109
 Card I/O Map 0–1 Offset Address Low 109
 I/O Window Control 105
 System I/O Map 0–1 End Address High 108
 System I/O Map 0–1 End Address Low 108
 System I/O Map 0–1 Start Address High 107
 System I/O Map 0–1 Start Address Low 107
 Memory Window Mapping
 Card Memory Map 0–4 Offset Address High 115
 Card Memory Map 0–4 Offset Address Low 114
 System Memory Map 0–4 End Address High 113
 System Memory Map 0–4 End Address Low 112
 System Memory Map 0–4 Start Address High 111
 System Memory Map 0–4 Start Address Low 110
window option
 I/O 27
 I/O-to-I/O window 28
 I/O-to-memory window 29
 memory 26
 memory-to-I/O window 28
 memory-to-memory 27
windowing capabilities 26
windows, memory mapping 110

Z

ZV (zoomed video) port 29
ZV port implementation, typical 30

Notes

Direct Sales Offices

Domestic

N. CALIFORNIA

Fremont
TEL: 510/623-8300
FAX: 510/252-6020

S. CALIFORNIA

Westlake Village
TEL: 805/371-5860
FAX: 805/371-5861

NORTHWESTERN AREA

Portland, OR
TEL: 503/620-5547
FAX: 503/620-5665

SOUTH CENTRAL AREA

Austin, TX
TEL: 512/255-0080
FAX: 512/255-0733

Houston, TX
TEL: 281/257-2525
FAX: 281/257-2555

NORTHEASTERN AREA

Andover, MA
TEL: 978/794-9992
FAX: 978/794-9998

SOUTHEASTERN AREA

Raleigh, NC
TEL: 919/859-5210
FAX: 919/859-5334

Boca Raton, FL
TEL: 561/395-1613
FAX: 561/395-1373

International

CHINA

Beijing
TEL: 86/10-6428-0783
FAX: 86/10-6428-0786

FRANCE

Paris
TEL: 33/1-48-12-2812
FAX: 33/1-48-12-2810

GERMANY

Herrsching
TEL: 49/81-52-92460
FAX: 49/81-52-924699

HONG KONG

Tsimshatsui
TEL: 852/2376-0801
FAX: 852/2375-1202

ITALY

Milan
TEL: 39/2-3360-5458
FAX: 39/2-3360-5426

JAPAN

Tokyo
TEL: 81/3-3340-9111
FAX: 81/3-3340-9120

KOREA

Seoul
TEL: 82/2-565-8561
FAX: 82/2-565-8565

SINGAPORE

TEL: 65/743-4111
FAX: 65/742-4111

TAIWAN

Taipei
TEL: 886/2-2718-4533
FAX: 886/2-2718-4526

UNITED KINGDOM

London, England
TEL: 44/01628-472211
FAX: 44/01628-486114

High-Value Systems in Silicon

Cirrus Logic is a premier supplier of advanced integrated circuits that combine mixed-signal processing, precision analog techniques, embedded processors, and application-specific algorithms into system-on-a-chip solutions for existing and emerging growth markets. Enhanced by strong systems expertise in selected markets, the company's products add high value to major brands worldwide in magnetic and optical storage, networking communications, consumer/professional audio, video, and imaging, and ultra-precision data acquisition.

Cirrus Logic's manufacturing strategy ensures maximum product quality and availability, as well as access to world-class processing technologies through joint ventures with IBM® and Lucent Technologies®.

Contact one of our systems and applications specialists to see how your company can benefit from the high value Cirrus Logic adds to its customers' products.

Copyright © 1998 Cirrus Logic, Inc. All rights reserved.

Advance product information describes products that are in development and subject to developmental changes. Cirrus Logic, Inc. has made best efforts to ensure that the information contained in this document is accurate and reliable. However, the information is subject to change without notice. No responsibility is assumed by Cirrus Logic, Inc. for the use of this information, nor for infringements of patents or other rights of third parties. This document is the property of Cirrus Logic, Inc. and implies no license under patents, copyrights, or trade secrets. No part of this publication may be copied, reproduced, stored in a retrieval system or transmitted in any form or by any means (electronic, mechanical, photographic, or otherwise) or used as the basis for manufacture or sale of any items without the prior written consent of Cirrus Logic, Inc. Cirrus, Cirrus Logic, AccuPak, Alpine, Clear3D, Crystal, CrystalClear, CrystalClear Imaging, CrystalWare, DirectVPM, DIVA, FastEn, FastPath, FeatureChips, FilterJet, Get into it, Good Data, IntelliFilter, Laguna, Laguna3D, LagunaTV, Matterhorn, Matterhorn3D, MediaDAC, MediaMax, Mergent, Mojave, MotionVideo, Multimedia in the Mix, MVA, SimulSCAN, S/LA, SmartAnalog, SMASH, SofTarget, SoundFusion, Stargate, Systems in Silicon, TextureJet, True-D, TVTap, UXART, VisualMedia, VPM, V-Port, V-Port Manager, Voyager, WavePort, and WebSet are trademarks of Cirrus Logic, Inc., which may be registered in some jurisdictions. Other trademarks in this document belong to their respective companies. CRUS and Cirrus Logic International, Ltd. are trade names of Cirrus Logic, Inc.

Cirrus Logic, Inc.
3100 West Warren Ave., Fremont, CA 94538
TEL: 510/623-8300 FAX: 510/252-6020

Publications Ordering: 800/359-6414 (USA) or 510/249-4200
Worldwide Web: <http://www.cirrus.com>

346833-003